



**VULCAN 2000**

**Motorcycle**

保存版

**OWNER'S MANUAL**



Whenever you see the symbols shown below, heed their instructions! Always follow safe operating and maintenance practices.

 **WARNING**

This warning symbol identifies special instructions or procedures which, if not correctly followed, could result in personal injury, or loss of life.

**CAUTION**

This caution symbol identifies special instructions or procedures which, if not strictly observed, could result in damage to or destruction of equipment.

**NOTE**

- *This note symbol indicates points of particular interest for more efficient and convenient operation.*

**NOTICE**

**THIS PRODUCT HAS BEEN MANUFACTURED FOR USE IN A REASONABLE AND PRUDENT MANNER BY A QUALIFIED OPERATOR AND AS A VEHICLE ONLY.**



**(Australian model only)**

**TAMPERING WITH NOISE CONTROL SYSTEM  
PROHIBITED**

**Owners are warned that the law may prohibit:**

- (a) The removal or rendering inoperative by any person other than for purposes of maintenance, repair or replacement, of any device or element of design incorporated into any new vehicle for the purpose of noise control prior to its sale or delivery to the ultimate purchaser or while it is in use; and
- (b) the use of the vehicle after such device or element of design has been removed or rendered inoperative by any person.

## FOREWORD

Congratulations on your purchase of a new Kawasaki Motorcycle. Your new motorcycle is the product of Kawasaki's advanced engineering, exhaustive testing, and continuous striving for superior reliability, safety and performance.

**Please read this Owner's Manual carefully before riding** so that you will be thoroughly familiar with the proper operation of your motorcycle's controls, its features, capabilities, and limitations. This manual offers many safe riding tips, but its purpose is not to provide instruction in all the techniques and skills required to ride a motorcycle safely. Kawasaki strongly recommends that all operators of this vehicle enroll in a motorcycle rider training program to attain awareness of the mental and physical requirements necessary for safe motorcycle operation.

To ensure a long, trouble-free life for your motorcycle, give it the proper care and maintenance described in this manual. For those who would like more detailed information on their Kawasaki Motorcycle, a Service Manual is available for purchase from any authorized Kawasaki motorcycle dealer. The Service Manual contains detailed disassembly and maintenance information. Those who plan to do their own work should, of course, be competent mechanics and possess the special tools described in the Service Manual.

Keep this Owner's Manual aboard your motorcycle at all times so that you can refer to it whenever you need information.

This manual should be considered a permanent part of the motorcycle and should remain with the motorcycle when it is sold.

All rights reserved. No part of this publication may be reproduced without our prior written permission.

This publication includes the latest information available at the time of printing. However, there may be minor differences between the actual product and illustrations and text in this manual.

All products are subject to change without prior notice or obligation.

**KAWASAKI HEAVY INDUSTRIES, LTD.**  
**Consumer Products & Machinery Company**

© 2003 Kawasaki Heavy Industries, Ltd.

Oct. 2003 (2). (M)

---

## TABLE OF CONTENTS

---

<b>Specifications</b> .....	8	Fuel Tank .....	27
<b>Location of Parts</b> .....	11	Side Stand .....	29
<b>General Information</b> .....	14	Side Covers.....	30
Meter Instruments .....	14	Tool Kit Case .....	31
Speedometer: .....	15	Seat.....	32
Digital Meter: .....	15	Helmet Hook .....	34
RESET Button and MODE		Steering Lock .....	35
Button: .....	19	Electric Accessory Connectors .....	36
Warning/Indicator Lights: .....	19	<b>Break-In</b> .....	38
Keys .....	21	<b>How to Ride the Motorcycle</b> .....	40
Ignition Switch .....	21	Starting the Engine .....	40
Right Handlebar Switches.....	23	Jump Starting .....	42
Engine Stop Switch: .....	23	Moving Off.....	45
Starter Button: .....	23	Shifting Gears .....	46
Left Handlebar Switches .....	24	Braking.....	48
Dimmer Switch: .....	24	Stopping the Engine.....	49
Turn Signal Switch:.....	24	Stopping the Motorcycle in an	
Horn Button: .....	24	Emergency .....	50
Brake Lever Adjusters.....	25	Parking .....	51
Fuel Tank Cap .....	26	Catalytic Converter.....	52



<b>Safe Operation</b> .....	53	Idle Speed .....	85
Daily Safety Checks .....	53	Clutch .....	86
Additional Considerations for High Speed Operation .....	55	Brakes .....	88
<b>Maintenance and Adjustment</b> .....	57	Brake Light Switches.....	92
Periodic Maintenance Chart.....	58	Rear Shock Absorbers .....	93
Engine Oil .....	67	Wheels .....	95
Cooling System .....	74	Battery .....	100
Drive Belt.....	78	Headlight Beam.....	106
Spark Plugs.....	79	Fuses .....	108
Valve Clearance .....	79	Cleaning Your Motorcycle .....	109
Kawasaki Clean Air System.....	80	<b>Storage</b> .....	114
Air Cleaner .....	81	<b>Environmental Protection</b> .....	117
Throttle Control System .....	83	<b>Location of Labels</b> .....	118

---

**Specifications**

---

**PERFORMANCE**

Maximum Horsepower	76 kW (103 PS) @4 800 r/min (rpm)
	(MY) (AU) 76 kW (103 PS) @5 100 r/min (rpm)
Maximum Torque	177 N·m (18.0 kg·m, 131 ft·lb) @3 200 r/min (rpm)
	(MY) (AU) 177 N·m (18.0 kg·m, 131 ft·lb) @3 000 r/min (rpm)

**DIMENSIONS**

Overall Length	2 535 mm (99.8 in.)
Overall Width	1 025 mm (40.35 in.)
	(AU) 985 mm (38.78 in.)
Overall Height	1 155 mm (45.47 in.)
Wheelbase	1 735 mm (68.31 in.)
Road Clearance	135 mm (5.31 in.)
Dry Weight	340 kg (750 lb)

**ENGINE**

Type	OHV, V-type 2-cylinder, 4-stroke, liquid-cooled
Displacement	2 053 mL (125.3 cu in.)
Bore x Stroke	103.0 x 123.2 mm (4.06 x 4.85 in.)
Compression Ratio	9.5 : 1
Starting System	Electric starter

Cylinder Numbering Method	Front to rear, 1-2
Firing Order	1-2
Carburetion System	Digital fuel injection system (DFI)
Ignition System	Battery and coil (transistorized ignition)
Ignition Timing (Electronically advanced)	Front: 13° BTDC @900 r/min (rpm) ~ 51° BTDC @4 000 r/min (rpm) Rear: 15° BTDC @900 r/min (rpm) ~ 51° BTDC @4 000 r/min (rpm)
Spark Plugs	NGK IZFR6F-11
Lubrication System	Forced lubrication (semi-dry sump)
Engine Oil	Type: API SE, SF or SG API SH or SJ with JASO MA SAE 10W-40
Coolant Capacity	Capacity: 5.5 L (5.8 US qt) 2.5 L (2.6 US qt)
<b>TRANSMISSION</b>	
Transmission Type	5-speed, constant mesh, return shift
Clutch Type	Wet, multi disc
Driving System	Belt drive
Primary Reduction Ratio	1.500 (48/32)

## 10 SPECIFICATIONS

Final Reduction Ratio		2.454 (48/44 × 72/32)
Overall Drive Ratio		2.686 (Top gear)
Gear Ratio	1st	2.550 (51/20)
	2nd	1.629 (44/27)
	3rd	1.218 (39/32)
	4th	0.939 (31/33)
	5th	0.729 (27/37)

### FRAME

Castor		32°
Trail		182 mm (7.2 in.)
Tire Size:	Front	150/80 R16 M/C 71V
	Rear	200/60 R16 MC 79V
Fuel Tank Capacity		21 L (5.5 US gal)

### ELECTRICAL EQUIPMENT

Battery		12 V 18 Ah
Headlight		12 V 65/55 W
Tail/Brake Light		12 V 5/21 W

(MY): Malaysian model

(AU): Australian model

Specifications subject to change without notice, and may not apply to every country.

---

**Location of Parts**

---

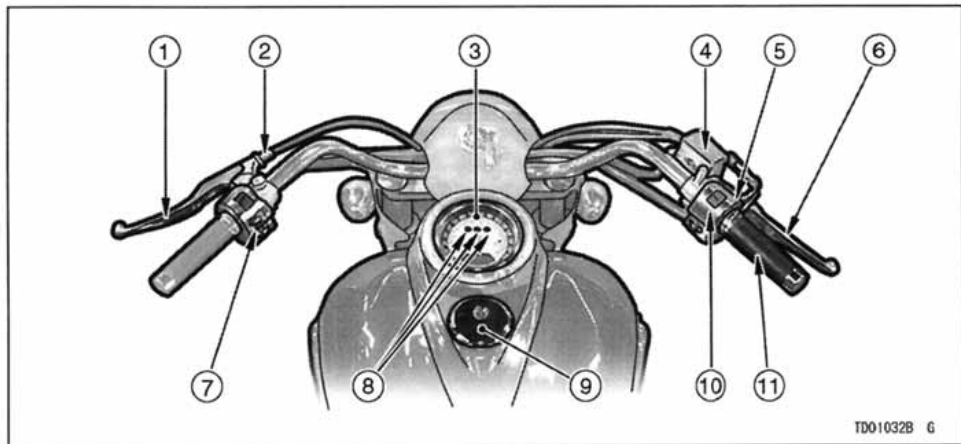

TD01032B G

1. Clutch Lever
2. Clutch Lever Adjuster
3. Meter Instruments
4. Brake Fluid Reservoir (Front)

5. Brake Lever Adjuster
6. Front Brake Lever
7. Left Handlebar
8. Indicator Lights

9. Fuel Tank Cap
10. Right Handlebar Switches
11. Throttle Grip

## 12 LOCATION OF PARTS

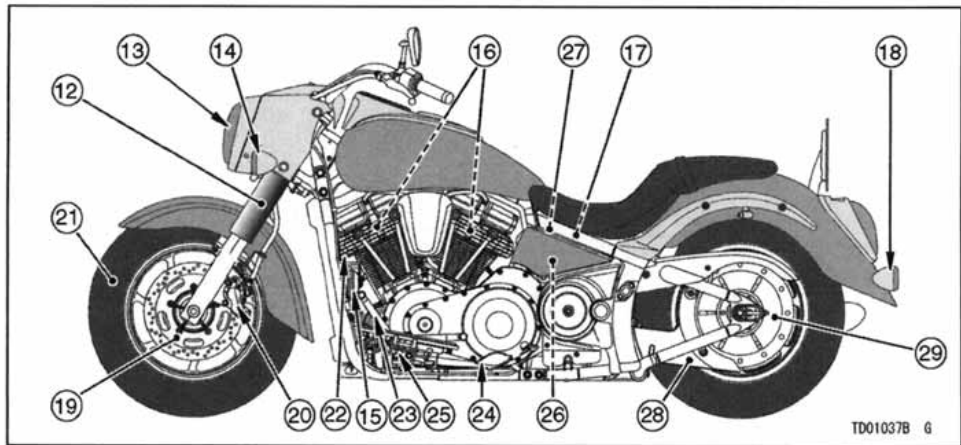

TD01037B G

- 12. Front Fork
- 13. Headlight
- 14. Turn Signal/Running Position Light
- 15. Horn
- 16. Spark Plugs
- 17. Battery

- 18. Turn Signal Light (Rear)
- 19. Brake Disc
- 20. Brake Caliper
- 21. Wheel
- 22. Radiator
- 23. Shift Pedal
- 24. Side Stand
- 25. Side Stand Switch

- 26. Junction Box (Fuses)
- 27. Rear Shock Absorber
- 28. Belt
- 29. Belt Pulley

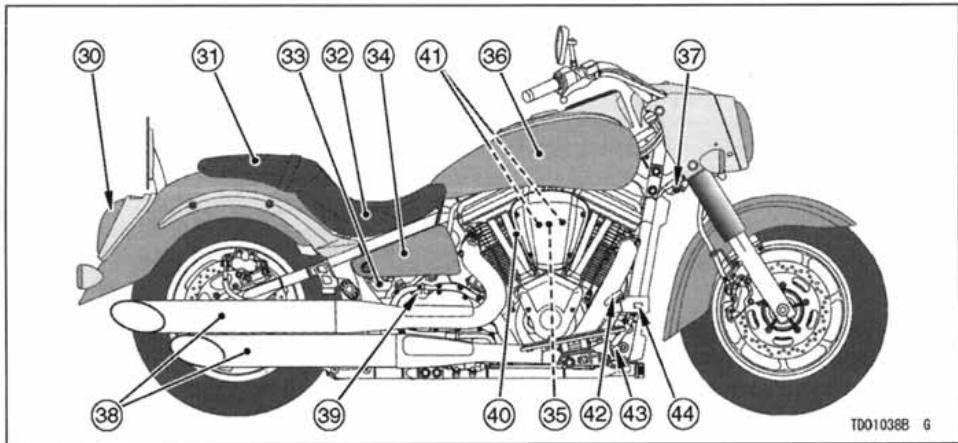

TD01038B G

- 30. Tail/Brake Light
- 31. Passenger's Seat
- 32. Rider's Seat
- 33. Coolant Reserve Tank
- 34. Tool Kit Case/Tool Kit
- 35. Air Cleaner Element

- 36. Fuel Tank
- 37. Steering Lock
- 38. Mufflers
- 39. Oil Level Gauge
- 40. Idle Speed Adjusting Screw

- 41. Throttle Valves
- 42. Rear Brake Pedal
- 43. Rear Brake Light Switch
- 44. Brake Fluid Reservoir (Rear)

Meter Instruments

- A. Speedometer
- B. Digital Meter
- C. Warning Light
- D. MODE Button
- E. Fuel Level Indicator Light
- F. RESET Button
- G. Neutral Indicator Light
- H. Turn Signal indicator Light
- I. High Beam Indicator Light

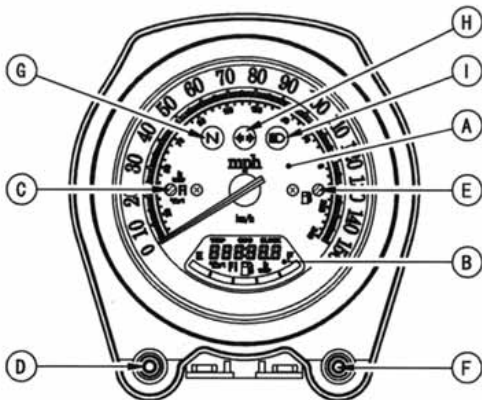





**Speedometer:**

The speedometer shows the speed of the vehicle.

The speedometer needle momentary points to the last reading when the ignition key is turned to "ON". This checks the operation of the speedometer needle. If the needle does not operate correctly, have the speedometer checked by an authorized Kawasaki dealer.

**Digital Meter:**

The LCD (Liquid Crystal Display) digital meter located in the speedometer face is used to display the odometer, trip meter, clock, fuel gauge, and the following warning symbols: oil pressure () , coolant temperature () , and fuel injection (FI). Pushing the MODE button shifts the display

through the following three modes: CLOCK, ODO, and TRIP. When the ignition key is turned to "ON", all the LCD segments are displayed for three seconds, then the clock or meters operates normally depending on the mode selected.

## 16 GENERAL INFORMATION

### Clock -

To adjust hours and minutes:

1. Turn the ignition key to "ON".
2. Push the MODE button to display the clock.
3. Push the RESET button for more than two seconds. Both the hour and minute displays start flashing.



4. Again push the RESET button. The hour display only flashes. Push the MODE button to advance the hours.



5. Push the RESET button. The hour display stops flashing and the minute display starts flashing. Push the MODE button to advance the minutes.



6. Push the RESET button. Both the hour and minute displays start flashing again.
7. Push the MODE button. The displays stop flashing and the clock starts working.

### NOTE

- Pushing the MODE button momentarily advances the hour or minute

*step by step. Pushing and holding the button advance the hour or minute continuously.*

- *The clock works normally from the back-up power while the ignition switch is turned off.*
- *When the battery is disconnected, the clock resets to 1:00, and starts working again when the battery is connected.*

### **Odometer -**

The odometer shows the total distance in kilometers (miles) that the vehicle has been ridden. This meter cannot be reset.



### **NOTE**

- *The data is maintained even if the battery is disconnected.*
- *When the figures come to 999999, they are stopped and locked.*

### **Trip Meter -**

The trip meter shows the distance in kilometers (miles) traveled since they were last reset to zero.

To reset a trip meter:

1. Push the MODE button to display the trip meter.
2. Push the RESET button and hold it in.
3. After two seconds, the figure display turns to 0.0, and then starts counting when the vehicle is operated. The meter counts until it is next reset.

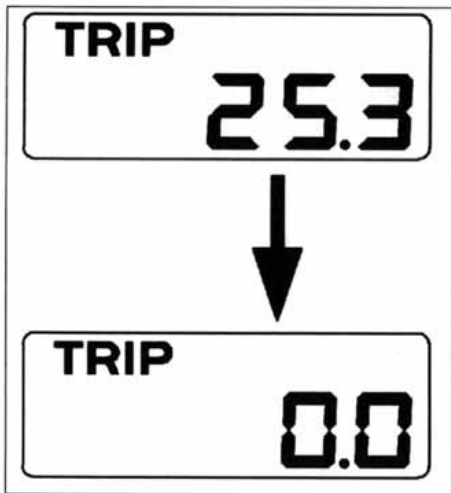

**NOTE**

- The data is maintained by the back-up power if the ignition key is turned to "OFF".

- When the trip meter reaches 9999.9 while running, it resets to 0.0 and continues counting .
- When the battery is disconnected, the meter display resets to 0.0.

**Fuel Gauge -**

The fuel in fuel tank is shown by the number of segments displayed. When the fuel tank is full, all the segments are displayed. As the fuel level in the tank goes down, the segments disappear one by one from F (full) to E (empty).

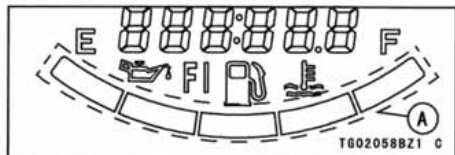

**A. Fuel Gauge**

**NOTE**

○ *If refueling the fuel into the fuel tank with the motorcycle held horizontal, the fuel gauge may not show the most right segment on the gauge.*

**RESET Button and MODE Button:**



The RESET button is used to reset the trip meter and to adjust the clock. The MODE button is used to shift through the digital meter modes and to adjust the clock.



**Warning/Indicator Lights:**

**N:** When the transmission is in neutral, the neutral indicator light is lit.

 : When the headlight is on high beam, the high beam indicator light is lit.

 : When the turn signal switch is pushed to the left or right, the turn signal indicator light starts flashing.

 : The warning light in the speedometer and the oil pressure warning (  ) symbol in the LCD digital meter go on whenever the oil pressure is dangerously low or the ignition switch is in the ON position with the engine not running, and go off when the engine oil pressure is high enough. Refer to the Maintenance and Adjustment chapter for more detailed engine oil information.

 : The warning light in the speedometer and the coolant temperature warning symbol (  ) in the LCD digital meter go on whenever the ignition key is turned to "ON" or the coolant temperature rises to 120°C or higher when the

## 20 GENERAL INFORMATION

motorcycle is in operation. After turning the ignition key to "ON", the coolant temperature warning symbol () goes off soon after it has been ensured that its circuit functions properly.

**FI:** The warning light in the speedometer and the fuel injection warning symbol (FI) in the LCD digital meter go on whenever the ignition key is turned to "ON" or trouble occurs in the fuel injection (FI) system. After turning the ignition key to "ON", the fuel injection warning symbol (FI) goes off soon after it has been ensured that its circuit functions properly. If the warning light stays on, have the FI system checked by an authorized Kawasaki dealer.

: The fuel level indicator light goes on when the ignition key is turned to "ON" and goes off soon after ensuring that its circuit functions properly. The indicator light also goes on when approximate 4.0 L (1.1 US gal) of fuel can be used. Refuel at the earliest opportunity when the fuel level indicator light comes on.

## Keys

This motorcycle has a combination key, which is used for the ignition switch, steering lock, right side cover lock, helmet hook, and fuel tank cap.

Blank keys are available at your Kawasaki dealers. Ask your dealer to make any additional spare keys you may need, using your original key as a master.

<b>CAUTION</b>
<b>Be sure not to attach the key to a key chain that may damage the finish of the motorcycle.</b>

## Ignition Switch

This is a three-position, key-operated switch. The key can be removed from the switch in any position (OFF, ON, P)

This ignition switch is designed so that the key can be removed from the switch in the ON position, and turned from ON position to the OFF or P(Park) position without the ignition key.

If the ignition key is attached to a key chain with the accessory that may damage the finish of the motorcycle, Kawasaki recommends that the ignition key be removed from the ignition switch while riding.

## 22 GENERAL INFORMATION

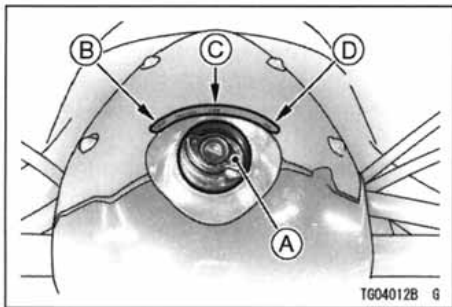

**A. Ignition Switch**

**B. OFF**

**C. ON**

**D. P(Park)**

<b>OFF</b>	Engine off. All electrical circuits off.
<b>ON</b>	Engine on. All electrical equipment can be used.
<b>P(Park)</b>	Engine off. Taillight and licence plate light on. All other electrical circuits cut off.

### NOTE

- *The city (except for Australia model), tail and, license plate lights are on whenever the ignition switch is in the ON position. The headlight goes on when the starter button is released after starting the engine. To avoid battery discharge, always start the engine immediately after turning the ignition key to ON.*
- *If you leave the motorcycle in the P(Park) position or in the ON position without the motorcycle running for a long time (one hour), the battery may become totally discharged.*
- *Be sure to turn the ignition key to OFF or P(Park) when parking the motorcycle.*



## Right Handlebar Switches

### Engine Stop Switch:

In addition to the ignition switch, the engine stop switch must be in the  position for the motorcycle to operate.

The engine stop switch is for emergency use. If some emergency requires stopping the engine, move the engine stop switch to the  position.

### NOTE

*○ Although the engine stop switch stops the engine, it does not turn off all the electrical circuits. Ordinarily, the ignition switch should be used to stop the engine.*

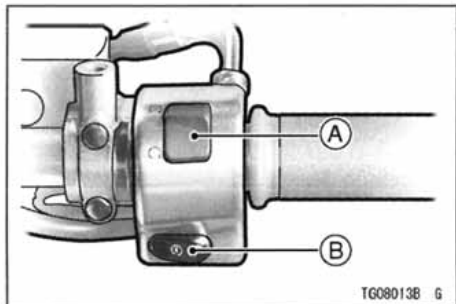

A. Engine Stop Switch    B. Starter Button

### Starter Button:

The starter button operates the electric starter when the transmission is in neutral.

Refer to the Starting the Engine section of the "How to Ride the Motorcycle" chapter for starting instructions.

## 24 GENERAL INFORMATION

### Left Handlebar Switches

#### Dimmer Switch:

High or low beam can be selected with the dimmer switch. When the headlight is on high beam (  ), the high beam indicator light is lit.

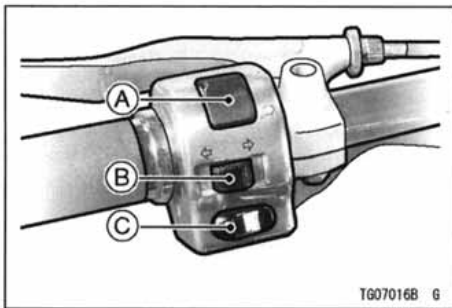

High beam.....(  )

Low beam.....(  )



A. Dimmer Switch      C. Horn Button  
B. Turn Signal Switch

#### Turn Signal Switch:

When the turn signal switch is turned to the left (  ) or right (  ), the corresponding turn signals flash on and off.

The turn signal switch is automatically canceled after it has first been on for 8 seconds, and then the motorcycle has traveled an additional 65 m (213 ft). However, make a practice of pushing the switch in to stop flashing.

#### Horn Button:

When the horn button is pushed, the horn sounds.

## Brake Lever Adjusters

There is an adjuster on the brake lever. The adjuster has 5 positions so that the released lever position can be adjusted to suit the operator's hands. Push the lever forward and turn the adjuster to align the number with the arrow mark on the lever holder. The distance from the grip to the released lever is minimum at Number 5 and maximum at Number 1.

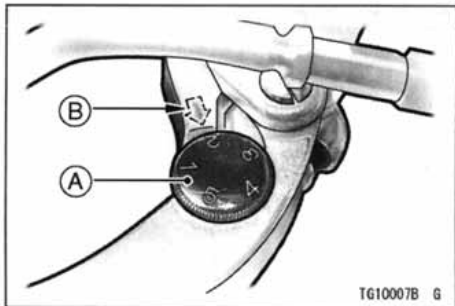

A. Adjuster

B. Arrow Mark

## 26 GENERAL INFORMATION

### Fuel Tank Cap

To open the fuel tank cap, insert the ignition key into the fuel tank cap and turn the key to the right.

To close the cap, push it down into place with the key inserted. The key can be removed by turning it to the left to the original position.

#### NOTE

- *The fuel tank cap cannot be closed without the key inserted, and the key cannot be removed unless the cap is locked properly.*
- *Do not push on the key to close the cap or the cap cannot be locked.*

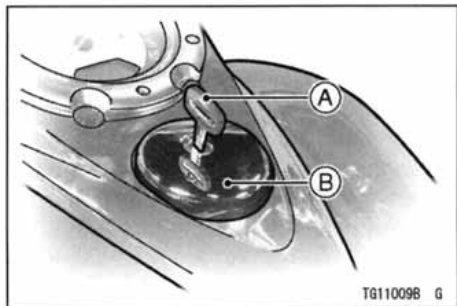

A. Ignition Key

B. Fuel Tank Cap

## Fuel Tank

Avoid filling the tank in the rain or where heavy dust is blowing so that the fuel does not get contaminated.

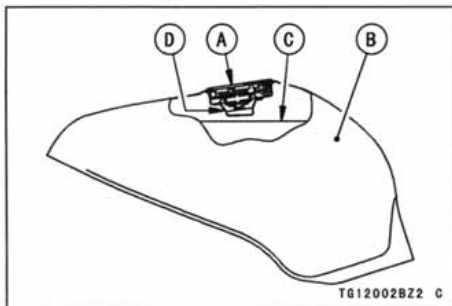

A. Tank Cap  
B. Fuel Tank

C. Top Level  
D. Filler Neck

## **!** WARNING

Gasoline is extremely flammable and can be explosive under certain conditions. Turn the ignition key to "OFF". Do not smoke. Make sure the area is well ventilated and free from any source of flame or sparks; this includes any appliance with a pilot light. Never fill the tank so the fuel level rises into the filler neck. If the tank is overfilled, heat may cause the fuel to expand and overflow through the vents in the tank cap.

After refueling, make sure the fuel tank cap is closed securely. If gasoline is spilled on the fuel tank, wipe it off immediately.

## 28 GENERAL INFORMATION

### Fuel Requirement

Your Kawasaki engine is designed to use only unleaded gasoline with a minimum octane rating of RON 95.

#### CAUTION

**Do not use leaded gasoline, as this will destroy the catalytic converter. (For further information, refer to the "Catalytic Converter" section in the "How to Ride the Motorcycle" chapter.)**

### *Octane Rating*

The octane rating of a gasoline is a measure of its resistance to detonation or "knocking." The term commonly used to describe a gasoline's octane

rating is the Research Octane Number (RON). Always use a gasoline with an octane rating equal to, or higher than, RON 95.

#### NOTE

- *If "knocking" or "pinging" occurs, use a different brand of gasoline or higher octane rating.*

#### CAUTION

**Use minimum of 95 octane gasoline only to prevent severe engine damage.**

## Side Stand

The motorcycle is equipped with a side stand.



A. Side Stand

Whenever the side stand is used, make it a practice to kick the stand fully up before sitting on the motorcycle.

## NOTE

- *The motorcycle is equipped with a side stand switch. This switch is designed so that the engine does not start if the transmission is in gear and the side stand is down.*

## NOTE

- *When using the side stand, turn the handlebar to the left.*

## 30 GENERAL INFORMATION

### Side Covers

The left and right side covers are removed, taking out the tool kit, and inspecting the fuses.

#### Right Side Cover Removal -

1. Insert the ignition key into the lock, and turn the key to the right.
2. Pull the side cover rear end outward.

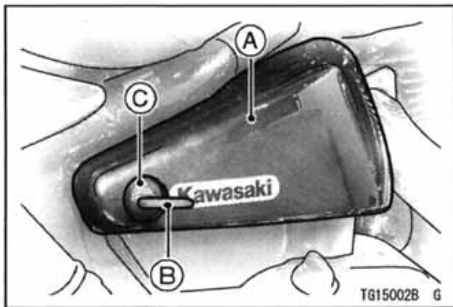

- A. Right Side Cover**    **C. Lock**  
**B. Ignition Key**

#### Left Side Cover Removal -

1. Remove the screw.
2. Pull the side cover outward.



- A. Screw**  
**B. Left Side Cover**



## Tool Kit Case

The tool kit case is located behind the right side cover.

Keep the tool kit in this case. The minor adjustments and replacement of parts explained in this manual can be performed with the tools in the kit.

- Open the tool kit case cover by pulling the knob.

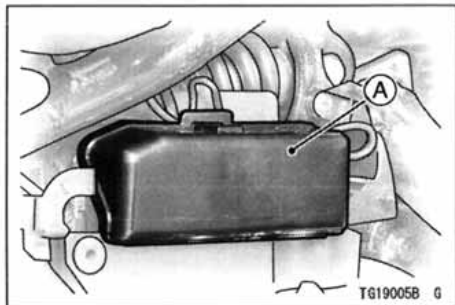

**A. Tool Kit Case**

## 32 GENERAL INFORMATION

### Seat

#### *Passenger's Seat Removal*

- Remove the right side cover, and then pull the lever.

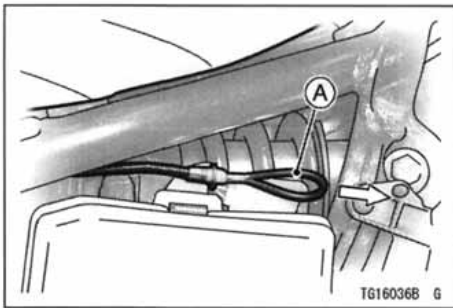

**A. Passenger's Seat Lever**

#### *Rider's Seat Removal*

- To remove the rider's seat, remove the bolt, and then pull the seat back-ward.

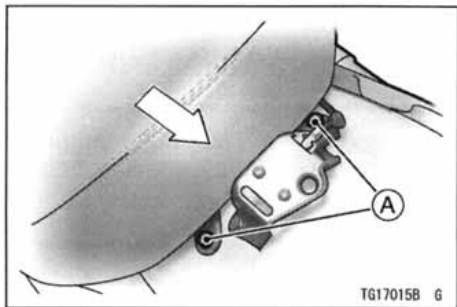

**A. Bolt**

#### *Rider's Seat Installation*

- To remove the rider's seat, remove the bolt, and then pull the seat back-ward.

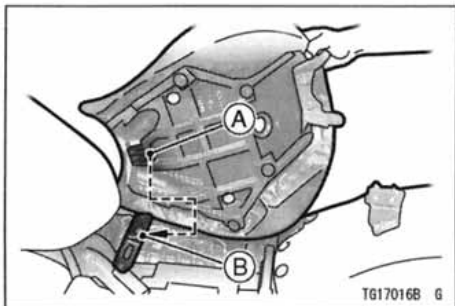

- A. Projection
- B. Receptacle

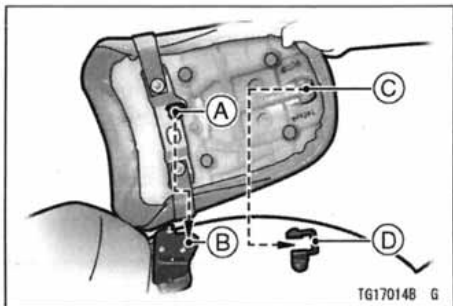

- A. Projection
- B. Hook
- C. Projection
- D. Receptacle

### *Passenger's Seat Installation*

- To install the passenger's seat, insert the projection at the front and the tab at the rear into the corresponding holders on the frame.

## 34 GENERAL INFORMATION

### Helmet Hook

Helmet can be secured to the motorcycle using the helmet hook. The helmet hook is located at the left side of the frame.

The helmet hook can be unlocked by inserting the ignition key into the lock, and turning the key to the right.

#### WARNING

**Do not ride the motorcycle with helmet attached to the hook. The helmet could cause an accident by distracting the operator or interfering with normal vehicle operation.**

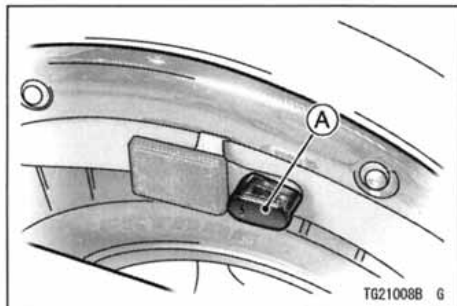

A. Helmet Hook

## Steering Lock

The motorcycle is equipped with the steering lock at the right side of the head pipe.

### To lock the steering:

1. Turn the handlebar to the left.
2. Insert the ignition key.
3. Turn the key half a turn to the left.
4. Pull the key out.

### NOTE

- *If the steering is hard to lock, turn the handlebar slightly to the left or the right.*
- *When unlocking the steering lock, turn the handlebar slightly to the right.*

## WARNING

**Unlock the steering before starting the engine. Attempting to drive with the steering locked could cause an accident.**

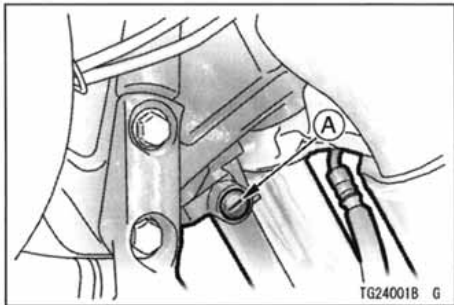

**A. Steering Lock**

## 36 GENERAL INFORMATION

### Electric Accessory Connectors

The electric power of the battery can be used through the electric accessory connectors regardless of ignition switch position. Observe and follow the notes listed below.

#### Electric Accessory Connectors

Location	Polarity	Wire Color
Under Rider's Seat	(+)	White/Blue
	(-)	Black/Yellow
Under Fuel Tank	(+)	White/Blue
	(-)	Black/Yellow
Maximum Current :		10 A



#### A. Electric Accessory Connectors

- When using the electric accessory connectors under the fuel tank, the electric accessory connection to the connectors should be done by an authorized Kawasaki dealer.

**CAUTION**

**Always install a fuse of 10A or less in the electrical accessory circuit. The vehicle has one fuse (10A) to protect the entire electrical system. If this fuse fails, the engine will not run.**

**Do not connect more than 70W of total load to the vehicle's electrical system or the battery may become discharged, even with the engine running.**

**WARNING**

**Take care not to pinch any wire between the seat and the frame or between other parts to avoid a short circuit.**

## Break-In

The first 1,600 km (1,000 mi) that the motorcycle is ridden is designated as the break-in period. If the motorcycle is not used carefully during this period, you may very well end up with a "broken down" instead of a "broken in" motorcycle after a few thousand kilometers.

The following rules should be observed during the break-in period.

- The table shows maximum recommended engine speed in km/h (rpm) during the break-in period.

Distance traveled	Gear position	km/h (mph)				
		1st	2nd	3rd	4th	5th
0 ~ 800 km (0 ~ 500 mi)		32	50	66	82	101
		(20)	(30)	(40)	(50)	(60)
800 ~ 1,600 km (500 ~ 1 000 mi)		40	64	85	106	130
		(25)	(40)	(50)	(65)	(80)



**NOTE**

- *When operating on public roadways, keep maximum speed under traffic law limits.*
- Do not start moving or race the engine immediately after starting it, even if the engine is already warm. Run the engine for two or three minutes at idle speed to give the oil a chance to work up into all the engine parts.
- Do not race the engine while the transmission is in neutral.

** WARNING**

**New tires are slippery and may cause loss of control and injury. A break-in period of 160 km (100 mi) is necessary to establish normal tire traction. During break-in, avoid sudden and maximum braking and acceleration, and hard cornering.**

In addition to the above, at 1,000 km (600 mi) it is extremely important that the owner has the initial maintenance service performed by an authorized Kawasaki dealer.

## How to Ride the Motorcycle

### Starting the Engine

- Check that the engine stop switch is in the  position.

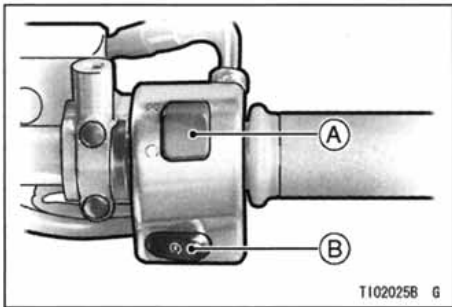

- A. Engine Stop Switch
- B. Starter Button

- Turn the ignition key to ON.
- Make sure the transmission is in neutral.

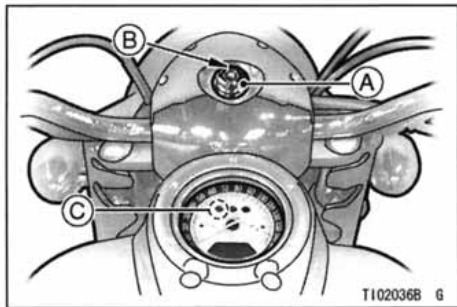

- A. Ignition Switch
- B. ON Position
- C. Neutral Indicator Light

### NOTE

- *The motorcycle is equipped with a vehicle-down sensor, which causes the engine to stop automatically when the motorcycle falls down. After righting the motorcycle, first turn*

the ignition key to "OFF" and then back to "ON" before starting the engine.

### CAUTION

Do not operate the starter continuously for more than 5 seconds, or the starter will overheat and the battery power will drop temporarily. Wait 15 seconds between each operation of the starter to let it cool and the battery power recover.

### NOTE

- The motorcycle is equipped with a starter lockout switch. This switch is designed so that the engine does not start if the transmission is in gear and

the side stand is down. However, the engine can be started if the clutch lever is pulled and the side stand is fully up.

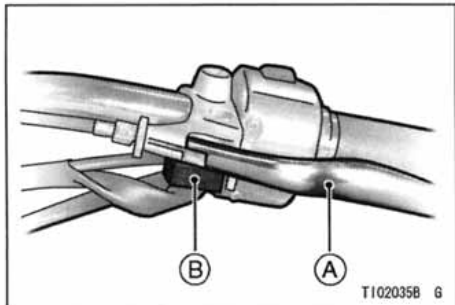

- A. Clutch Lever
- B. Starter Lockout Switch

**CAUTION**

**Do not let the engine idle longer than five minutes, or engine overheating and damage may occur.**

**Jump Starting**

If your motorcycle battery is "run down," it should be removed and charged. If this is not practical, a 12 volt booster battery and jumper cables may be used to start the engine.

**⚠ WARNING**

Battery acid generates hydrogen gas which is flammable and explosive under certain conditions. It is present within a battery at all times, even in a discharged condition. Keep all flames and sparks (cigarettes) away from the battery. Wear eye protection when working with a battery. In the event of battery acid contact with skin, eyes, or clothing, wash the affected areas immediately with water for at least five minutes. Seek medical attention.

*Connecting Jumper Cables*

- Remove the rider's seat.
- Make sure the ignition key is turned to "OFF."

- Connect a jumper cable from the positive (+) terminal of the booster battery to the positive (+) terminal of the motorcycle battery.

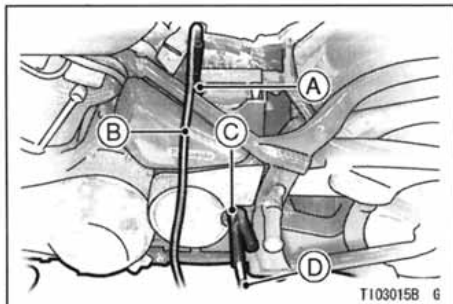

- A. Motorcycle Battery Positive (+) Terminal  
 B. From Booster Battery Positive (+) Terminal  
 C. Frame Earth Bracket  
 D. From Booster Battery Negative (-) Terminal

#### 44 HOW TO RIDE THE MOTORCYCLE

- Connect another jumper cable from the negative (-) terminal of the booster battery to your motorcycle frame earth bracket. Do not use the negative (-) terminal of the battery.

#### WARNING

**Do not make this last connection at the fuel system or battery. Take care that you do not touch the positive and negative cables together, and do not lean over the battery when making this last connection. Do not jump start a frozen battery. It could explode. Do not reverse polarity by connecting positive (+) to negative (-), or a battery explosion and serious damage to the electrical system may occur.**

- Follow the standard engine starting procedure.

#### CAUTION

**Do not operate the starter continuously for more than 5 seconds or the starter will overheat and the battery power will drop temporarily. Wait 15 seconds between each operation of the starter to let it cool and the battery power recover.**

- After the engine has started, disconnect the jumper cables. Disconnect the negative (-) cable from the motorcycle first. Reinstall the rider's seat.

## Moving Off

- Check that the side stand is up.
- Pull in the clutch lever.
- Shift into 1st gear.
- Open the throttle a little, and start to let out the clutch lever very slowly.
- As the clutch starts to engage, open the throttle a little more, giving the engine just enough fuel to keep it from stalling.

## NOTE

- *The motorcycle is equipped with a side stand switch. This switch is designed so that the engine does not start if the transmission is in gear and the side stand is down.*

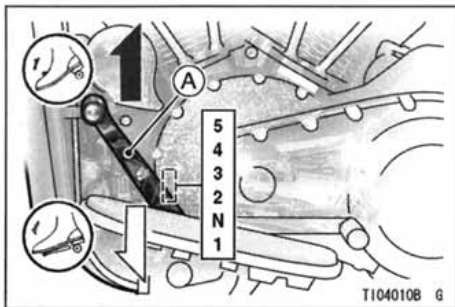

A. Shift Pedal

## Shifting Gears

- Close the throttle while pulling in the clutch lever.
- Shift into the next higher or lower gear. For smooth riding, shift up or down when the motorcycle is operated the speeds shown in the table below.

### WARNING

When shifting down to a lower gear, do not shift at such a high speed that the engine r/min (rpm) jumps excessively. Not only can this cause engine damage, but the rear wheel may skid and cause an accident. Downshifting should be done below the vehicle speeds for each gear shown in the table.

- Open the throttle part way, while releasing the clutch lever.

### NOTE

- *The transmission is equipped with a positive neutral finder. When the motorcycle is standing still, the transmission cannot be shifted past neutral from 1st gear. To use the positive neutral finder, shift down to 1st gear, then lift up on the shift pedal while standing still. The transmission will shift only into neutral.*



**Vehicle speed when downshifting**

Shifting down	km/h (mph)
5th → 4th	40 (25)
4th → 3rd	30 (19)
3rd → 2nd	20 (12)
2nd → 1st	15 (9)

## Braking

- Close the throttle completely, leaving the clutch engaged (except when shifting gears) so that the engine will help slow down the motorcycle.
- Shift down one gear at a time so that you are in 1st gear when you come to a complete stop.
- When stopping, always apply both brakes at the same time. Normally the front brake should be applied a little more than the rear. Shift down or fully disengage the clutch as necessary to keep the engine from stalling.
- Never lock the brakes, or it will cause the tires to skid. When turning a corner, it is better not to brake at all. Reduce your speed before you get into the corner.
- For emergency braking, disregard downshifting, and concentrate on applying the brakes as hard as possible without skidding.

## CAUTION

In order to protect the emission control parts, do not turn off the ignition switch when the motorcycle is in motion.

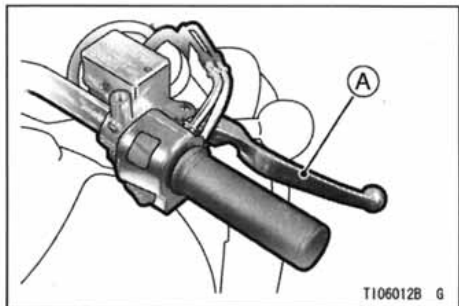

A. Front Brake Lever

T106012B G

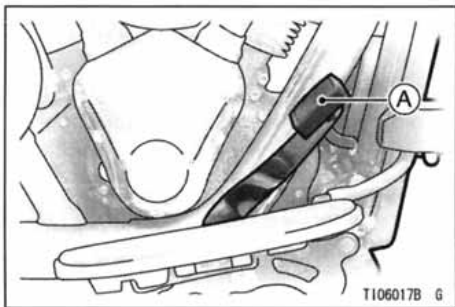

**A. Rear Brake Pedal**

## Stopping the Engine

- Close the throttle completely.
- Shift the transmission into neutral.
- Turn the ignition key to "OFF".
- Support the motorcycle on a firm, level surface with the side stand.
- Lock the steering.

## NOTE

- *The motorcycle is equipped with a vehicle-down sensor, which causes the engine to stop automatically when the motorcycle falls down. After righting the motorcycle, first turn the ignition key to "OFF" and then back to "ON" before starting the engine.*

## **Stopping the Motorcycle in an Emergency**

Your Kawasaki Motorcycle has been designed and manufactured to provide you optimum safety and convenience. However, in order to fully benefit from Kawasaki's safety engineering and craftsmanship, it is essential that you, the owner and operator, properly maintain your motorcycle and become thoroughly familiar with its operation. Improper maintenance can create a dangerous situation known as throttle failure.

Two of the most common causes of throttle failure are:

1. An improperly serviced or clogged air cleaner may allow dirt and dust to enter the throttle body and stick the throttle open.

2. During removal of the air cleaner, dirt is allowed to enter and jam the throttle body.

In an emergency situation such as throttle failure, your vehicle may be stopped by applying the brakes and disengaging the clutch. Once this stopping procedure is initiated, the engine stop switch may be used to stop the engine. If the engine stop switch is used, turn off the ignition switch after stopping the motorcycle.

## Parking

- Shift the transmission into neutral and turn the ignition key to "OFF".
- Support the motorcycle on a firm, level surface with the side stand.

### CAUTION

**Do not park on a soft or steeply inclined surface, or the motorcycle may fall over.**

- If parking inside a garage or other structure, be sure it is well ventilated and the motorcycle is not close to any source of flame or sparks; this includes any appliance with a pilot light.



### WARNING

**Gasoline is extremely flammable and can be explosive under certain conditions.**

- Lock the steering to help prevent theft.

### NOTE

- *When stopping near traffic at night, you can leave the taillight, licence plate light on for greater visibility by turning the ignition key to the P(Park) position.*
- *Do not leave the ignition switch at P position too long, or the battery will discharge.*

### **Catalytic Converter**

This motorcycle is equipped with a catalytic converter in the exhaust system. Platinum and Rhodium in the converter react with harmful carbon monoxide and hydrocarbons to convert them into harmless carbon dioxide and water resulting in much cleaner exhaust gases to be discharged into the atmosphere.

For proper operation of the catalytic converter, the following cautions must be observed.

- This model's muffler and exhaust gas are hotter than usual because of the chemical reaction that takes place in the catalytic converter. Although the muffler is made of double tubing to reduce heat transfer the temperature on the muffler surface is very hot.

- Use only unleaded gasoline. Never use leaded gasoline. Leaded gasoline significantly reduces the capability of the catalytic converter.
- Do not coast the vehicle with the ignition switch and/or engine stop switch off. Do not attempt to start the engine by rolling the vehicle if the battery is discharged. Do not operate the vehicle with the engine or any one cylinder misfiring. Under these conditions unburned air/fuel mixture flowing out of engine excessively accelerates reaction in the converter allowing the converter to overheat and become damaged when the engine is hot, or reduces converter performance when the engine is cold.

## Safe Operation

### Daily Safety Checks

Check the following items each day before you ride. The time required is minimal, and habitual performance of these checks will help ensure you a safe, reliable ride.

If any irregularities are found during these checks, refer to the Maintenance and Adjustment chapter or see your dealer for the action required to return the motorcycle to a safe operating condition.

### WARNING

**Failure to perform these checks every day before you ride may result in serious damage or a severe accident.**

Fuel ..... Adequate supply in tank, no leaks.

Engine oil ..... Oil level between level lines.

Tires ..... Air pressure (when cold):

Front	Up to 185 kg Load (408 lb)	250 kPa (2.5 kgf/cm <sup>2</sup> , 36 psi)
Rear	Up to 185 kg Load (408 lb)	290 kPa (2.9 kgf/cm <sup>2</sup> , 42 psi)

Install the air valve cap.

## 54 SAFE OPERATION

Nuts, bolts, fasteners ..	Check that steering and suspension components, axles, and all controls are properly tightened or fastened.
Steering .....	Action smooth but not loose from lock to lock. No binding of control cables.
Brakes .....	Brake pad wear: Lining thickness more than 1 mm (0.04 in.) left. No brake fluid leakage.
Throttle .....	Throttle grip play 2 ~ 3 mm (0.08 ~ 0.12 in.).
Clutch .....	Clutch lever play 2 ~ 3 mm (0.08 ~ 0.12 in.). Clutch lever operates smoothly.
Coolant .....	No coolant leakage. Coolant level between level lines (when engine is cold).
Electrical equipment ...	All lights and horn work.
Engine stop switch .....	Stops engine.
Side stand .....	Returns to its fully up position by spring tension. Return spring not weak or not damaged.

Refer to the "Daily Safety Checks" caution label attached to the back of the left side cover.



## Additional Considerations for High Speed Operation

### WARNING

**Handling characteristics of a motorcycle at high speeds may vary from those you are familiar with at legal highway speeds. Do not attempt high speed operation unless you have received sufficient training and have the required skills.**

**Brakes:** The importance of the brakes, especially during high speed operation, cannot be overemphasized. Check to see that they are correctly adjusted and functioning properly.

**Steering:** Looseness in the steering can cause loss of control. Check to see that the handlebar turns freely but has no play.

**Tires:** High speed operation is hard on tires, and good tires are crucial for riding safety. Examine their overall condition, inflate them to the proper pressure, and check the wheel balance.

**Fuel:** Have sufficient fuel for the high fuel consumption during high speed operation.

**Engine Oil:** To avoid engine seizure and resulting loss of control, make sure that the oil level is at the upper level line.

**Coolant:** To avoid overheating, check that the coolant level is at the upper level line.

## 56 SAFE OPERATION

**Electrical Equipment:** Make sure that the headlight, tail/brake light, turn signals, horn, etc., all work properly.

**Miscellaneous:** Make sure that all nuts and bolts are tight and that all safety related parts are in good condition.

---

## Maintenance and Adjustment

---

The maintenance and adjustments outlined in this chapter are easily carried out and must be done in accordance with the Periodic Maintenance Chart to keep the motorcycle in good running condition. **The initial maintenance is vitally important and must not be neglected.**

If you are in doubt as to any adjustment or vehicle operation, please ask your authorized Kawasaki dealer to check the motorcycle.

Please note that Kawasaki cannot assume any responsibility for damage resulting from incorrect maintenance or improper adjustment done by the owner.

## Periodic Maintenance Chart

K : Should be serviced by an authorized Kawasaki dealer.

\* : For higher odometer readings, repeat at the frequency interval established here.

# : Service more frequently when operating in severe conditions: dusty, wet, muddy, high speed, or frequent starting/stopping.

### 1. Periodic Inspection (Engine Related Item)

Frequency	Whichever comes first ↓	*Odometer Reading × 1000 km ( × 1000 mile)							See Page
		1 (0.6)	6 (4)	12 (7.5)	18 (12)	24 (15)	30 (20)	36 (24)	
Operation (Engine items)	Every								
Throttle control system (play, smooth return, no drag): check	year	●		●		●		●	83
Idle speed: check		●		●		●		●	85
<b>K</b> Spark plug condition: check				●		●		●	79
<b>K</b> Fuel hoses (no leak): check	year	●		●		●		●	—

Operation (Engine items)	Frequency	Whichever comes first ↓ Every							*Odometer Reading × 1000 km ( × 1000 mile)	See Page
		1 (0.6)	6 (4)	12 (7.5)	18 (12)	24 (15)	30 (20)	36 (24)		
<b>K</b> Fuel hoses and pipe (no damage): check	year	•		•		•		•	—	
<b>K</b> Fuel hoses and pipe connections: check	year	•		•		•		•	—	
Coolant level: check		•		•		•		•	76	
Radiator hoses and pipe(no leak): check	year	•		•		•		•	74	
Radiator hoses and pipe (no damage): check	year	•		•		•		•	74	
Radiator hoses and pipe connections: check	year	•		•		•		•	74	
<b>K</b> Air suction system (no damage): check				•		•		•	80	



Frequency	Whichever comes first ↓	*Odometer Reading × 1000 km ( × 1000 mile)							See Page
		→	1 (0.6)	6 (4)	12 (7.5)	18 (12)	24 (15)	30 (20)	
Operation (Chassis items)	Every								
Brakes (effectiveness, no drag): check	year	•	•	•	•	•	•	•	91
Brake pads (wear): check #			•	•	•	•	•	•	88
Brake fluid level: check	6 month	•	•	•	•	•	•	•	89
Brake light switch (operation): check		•	•	•	•	•	•	•	92
<b>Wheels and tire</b>									
Tire (air pressure): check	year			•		•		•	96
Wheels/tires (no damage): check				•		•		•	97
Tire (tread wear, no abnormal wear): check				•		•		•	97

## 62 MAINTENANCE AND ADJUSTMENT

Frequency	Whichever comes first ↓	*Odometer Reading × 1000 km ( × 1000 mile)							See Page
		1 (0.6)	6 (4)	12 (7.5)	18 (12)	24 (15)	30 (20)	36 (24)	
Operation (Chassis items)	Every								
<b>K</b> Wheel bearings (no damage): check	year			•		•		•	—
<b>Suspension</b>									
Front forks/rear shock absorber (smooth stroke): check				•		•		•	—
Front forks/rear shock absorber (no oil leak): check	year			•		•		•	—
<b>K</b> Swingarm pivot - lubricate						•			—
<b>Clutch and drive belt</b>									
Clutch (play, engagement, disengagement): check		•		•		•		•	86



Frequency	Whichever comes first ↓	*Odometer Reading × 1000 km ( × 1000 mile)							See Page
		1 (0.6)	6 (4)	12 (7.5)	18 (12)	24 (15)	30 (20)	36 (24)	
Operation (Chassis items)	Every								
<b>K</b> Belt wear and damage: check		•	•	•	•	•	•	•	78
Belt deflection: check		•	•	•	•	•	•	•	78
<b>Electrical system</b>									
Lights and switches (operation): check	year			•		•		•	–
Headlight aim: check	year			•		•		•	106
Side stand switch (operation): check	year			•		•		•	–
Engine stop switch (operation): check	year			•		•		•	–

## 64 MAINTENANCE AND ADJUSTMENT

Frequency	Whichever comes first ↓	*Odometer Reading × 1000 km ( × 1000 mile)							See Page
		1 (0.6)	6 (4)	12 (7.5)	18 (12)	24 (15)	30 (20)	36 (24)	
Operation (Chassis items)	Every								
<b>Chassis</b>									
<b>K</b> Chassis parts: lubricate	year			●		●		●	—
<b>K</b> Bolts and nuts (tightness): check		●		●		●		●	—

## 3. Periodic Replacement

Items	Frequency	*Odometer Reading × 1000 km (× 1000 mile)					See Page
	Whichever comes first ↓	1 (0.6)	12 (7.5)	24 (15)	36 (24)	48 (30)	
K Brake hoses and pipe	4 years					●	—
K Brake fluid (front and rear)	2 years			●		●	91
K Rubber parts of master cylinder and caliper	4 years					●	—
K Spark plug						●	79
K Air cleaner element #		Every 18 000 km (12 000 mile)					81
Engine oil #	year	●	●	●	●	●	70
K Oil filter	year	●	●	●	●	●	70
K Fuel hoses and pipe	4 years					●	—

## 66 MAINTENANCE AND ADJUSTMENT

Items to change or replace and pipe	Frequency	*Odometer Reading × 1000 km (× 1000 mile)					See Page
	Whichever comes first ↓ Every	1 (0.6)	12 (7.5)	24 (15)	36 (24)	48 (30)	
<b>K</b> Coolant	3 years				●		78
<b>K</b> Radiator hoses and O-rings	3 years				●		—

## Engine Oil

In order for the engine, transmission, and clutch to function properly, maintain the engine oil at the proper level, and change the oil and replace the oil filter in accordance with the Periodic Maintenance Chart. Not only do dirt and metal particles collect in the oil, but the oil itself loses its lubricative quality if used too long.

Because of the semi-dry sump lubrication system, the engine oil level indicated on the dipstick will fluctuate depending on the motorcycle's position and engine speed when the engine is shut off. To ensure a proper reading of the engine oil level, follow the Oil Level Inspection procedures closely.

### WARNING

**Motorcycle operation with insufficient, deteriorated, or contaminated engine oil will cause accelerated wear and may result in engine or transmission seizure, accident, and injury.**

### CAUTION

**Racing the engine before the oil reaches every part can cause engine seizure.**

#### *Oil Level Inspection*

- If the oil has just been changed, let the motorcycle sit a few minutes allowing the oil to settle.

## 68 MAINTENANCE AND ADJUSTMENT

- Start the engine and run it for several minutes at **idle speed while on the side stand. Do not run the engine at high engine speed.**
- Stop the engine and wait several minutes for the oil to settle.
- Remove the oil filler cap/dipstick.
- Wipe the dipstick clean.
- With the motorcycle perpendicular to the ground, thread the oil filler cap/dipstick fully clockwise then remove.
- Check the engine oil level on the dipstick. The oil level should come up between the low and high level lines on the dipstick.

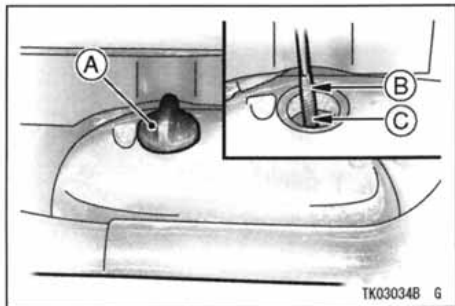

- A. Oil Filler Cap/Dipstick**
- B. High Level Line**
- C. Low Level Line**

same type and brand of oil that is already in the engine.

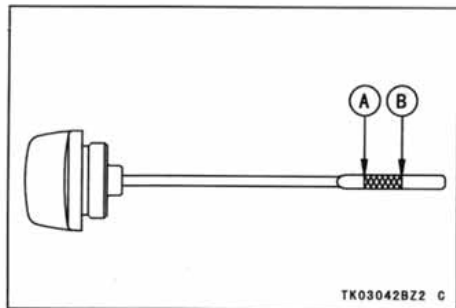

- A. High Level Line**  
**B. Low Level Line**

- If the oil level is too high, remove the excess oil through the oil filler opening using a syringe or some other suitable device.
- If the oil level is too low, add the oil to reach the correct level. Use the

### CAUTION

If the engine oil gets extremely low or if the oil pump does not function properly or oil passages are clogged, the warning light in the speedometer and oil pressure warning symbol in the digital meter will light. If this light stays on when the engine speed is slightly above the idle speed, stop the engine immediately and find the cause.

## 70 MAINTENANCE AND ADJUSTMENT

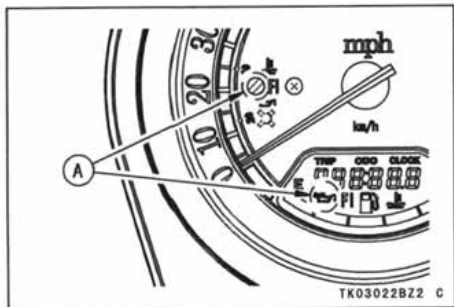

A. Oil Pressure Warning Light

### *Oil and/or Oil Filter Change*

- Warm up the engine thoroughly, and then stop it.

- Place an oil pan beneath the engine.
- Remove the engine oil drain plug.

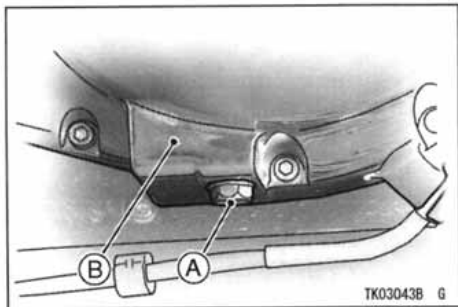

A. Engine Oil Drain Plug  
B. Outer Clutch Cover



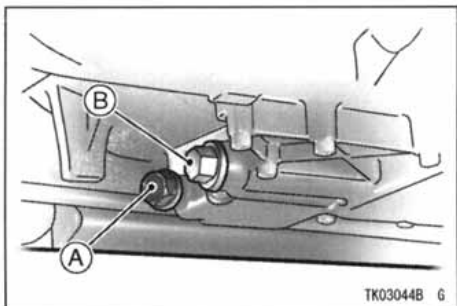

- A. Engine Oil Drain Plug
- B. Engine Oil Drain Plug

- Let the oil completely drain with the motorcycle perpendicular to the ground.

**⚠ WARNING**

**Motor oil is a toxic substance. Dispose of used oil properly. Contact your local authorities for approved disposal methods or possible recycling.**

- If the oil filter is to be replaced, remove the oil filter cartridge and replace it with a new one.

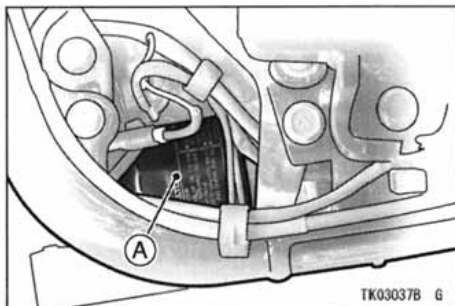

- A. Cartridge

## 72 MAINTENANCE AND ADJUSTMENT

- Apply a thin film of oil to the packing and tighten the cartridge to the specified torque.

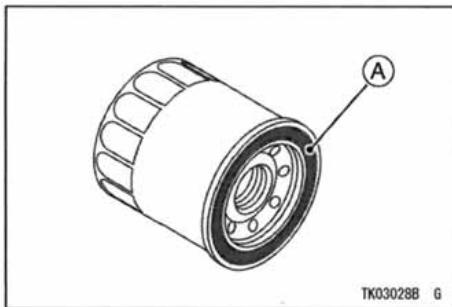

### A. Packing

- Install the engine oil drain plug with a new gasket and tighten it to the specified torque.

## NOTE

○ *Replace any gasket with a new one.*

- Fill the engine up to the upper level line with a good quality engine oil specified in the table.
- Start the engine.
- Check the oil level and for oil leakage.

### Tightening Torque

Engine Drain Plug:

20 N·m (2.0 kgf·m, 14.5 ft·lb)

Cartridge:

17.5 N·m (1.75 kgf·m, 12.6 ft·lb)

### Recommended Engine Oil

Type: API SE, SF or SG

: API SH or SJ with  
JASO MA

Viscosity: SAE 10W-40

### Engine Oil Capacity

Capacity: 4.4 L (4.7 US qt)  
 [when filter is not removed]  
 4.6 L (4.9 US qt)  
 [when filter is removed]  
 5.5 L (5.8 US qt)  
 [when engine is completely dry]

Although 10W-40 engine oil is the recommended oil for most conditions, the oil viscosity may need to be changed to accommodate atmospheric conditions in your riding area.

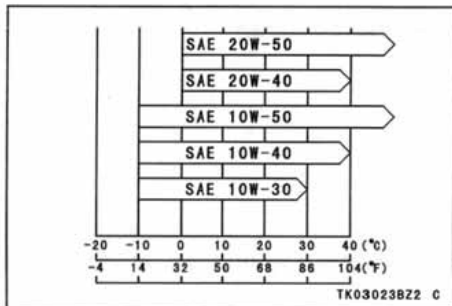

## Cooling System

### Radiator and Cooling Fin -

Check the radiator fins for obstruction by insects or mud. Clean off any obstructions with a stream of low-pressure water.

 **WARNING**

The cooling fan turns on automatically, even with the ignition switch off. Keep your hands and clothing away from the fan blades at all times.

### CAUTION

Using high-pressure water, as from a car wash facility, could damage the radiator fins and impair the radiator's effectiveness. Do not obstruct or deflect airflow through the radiator by installing unauthorized accessories in front of the radiator or behind the cooling fan. Interference with the radiator airflow can lead to overheating and consequent engine damage.

### Radiator Hoses -

Check the radiator hoses for cracks or deterioration, and connections for looseness in accordance with the Periodic Maintenance Chart.

## Coolant -

Coolant absorbs excessive heat from the engine and transfers it to the air at the radiator. If the coolant level becomes low, the engine overheats and may suffer severe damage. Check the coolant level each day before riding the motorcycle, and replenish coolant if the level is low. Change the coolant in accordance with the Periodic Maintenance Chart.

### *Information for Coolant*

To protect the cooling system (consisting of the aluminum engine and radiator) from rust and corrosion, the use of corrosion and rust inhibitor chemicals in the coolant is essential. If coolant containing corrosion and rust

inhibitor chemicals is not used, over a period of time, the cooling system accumulates rust and scale in the water jacket and radiator. This will clog up the coolant passages, and considerably reduce the efficiency of the cooling system.

### **WARNING**

**Use coolant containing corrosion inhibitors made specifically for aluminum engines and radiators in accordance with the instructions of the manufacturer. Chemicals are harmful to the human body.**

Soft or distilled water must be used with the antifreeze (see below for antifreeze) in the cooling system.

**CAUTION**

If hard water is used in the system, it causes scale accumulation in the water passages, and considerably reduces the efficiency of the cooling system.

If the lowest ambient temperature encountered falls below the freezing point of water, use permanent antifreeze in the coolant to protect the cooling system against engine and radiator freeze-up, as well as from rust and corrosion.

Use a permanent type of antifreeze (soft water and ethylene glycol plus corrosion and rust inhibitor chemicals for aluminum engines and radiators) in the cooling system. On the mixture ratio of coolant, choose the suitable one referring to the relation between freezing point and strength directed on the container.

**CAUTION**

Permanent types of antifreeze on the market have anti-corrosion and anti-rust properties. When it is diluted excessively, it loses its anti-corrosion property. Dilute a permanent type of antifreeze in accordance with the instructions of the manufacturer.

**NOTE**

- *A permanent type of antifreeze is installed in the cooling system when shipped. It is colored green and contains ethylene glycol. It is mixed at 50% and has the freezing point of  $-35^{\circ}\text{C}$  ( $-31^{\circ}\text{F}$ ).*

*Coolant Level Inspection*

- Situate the motorcycle so that it is perpendicular to the ground.

- Check the coolant level through the coolant level gauge. The coolant level should be between the F(Full) and L(Low) marks.

### NOTE

- Check the level when the engine is cold (room or atmospheric temperature).

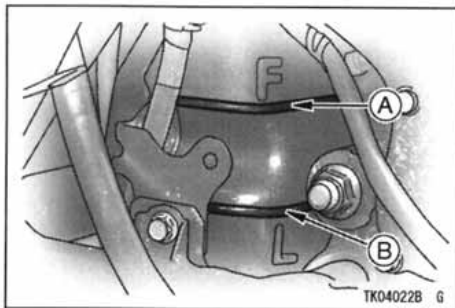

A. Full

B. Low

- If the amount of coolant is insufficient, open the cap from the reserve tank and add coolant through the filler opening to the F(Full) mark.
- Install the cap.

### NOTE

- In an emergency you can add water alone to the coolant reserve tank, however it must be returned to the correct mixture ratio by the addition of antifreeze concentrate as soon as possible.

### CAUTION

If coolant must be added often, or the reserve tank completely runs dry, there is probably leakage in the system. Have the cooling system inspected by your authorized Kawasaki dealer.

## 78 MAINTENANCE AND ADJUSTMENT

### *Coolant Change*

Have the coolant changed by an authorized Kawasaki dealer.

### **Drive Belt**

In order for the belt and belt pulleys to function properly, check the drive belt in accordance with the Periodic Maintenance Chart.

Belt check and adjustment should be done by an authorized Kawasaki dealer.

<b>CAUTION</b>
<b>Improper drive belt deflection can result in belt damage.</b>



## Spark Plugs

The standard spark plug is shown in the table. The spark plugs check and replacement should be done by an authorized Kawasaki dealer.

### Spark Plug

Standard Plug	NGK IZFR6F11
Plug Gap	1.0 ~ 1.1 mm (0.040 ~ 0.044 in.)
Tightening Torque	17 N·m (1.7 kgf·m, 12.3 ft·lb)

## NOTE

- *Fit the plug cap securely onto the spark plug, and pull the cap lightly to make sure that it is properly installed.*

## Valve Clearance

Valve and valve seat wear is automatically compensated for the valve clearance. So inspection and adjustment of the valve clearance are not necessary on this motorcycle.

### **Kawasaki Clean Air System**

The Kawasaki Clean Air System (KCA) is a secondary air suction system that helps the exhaust gases to burn more completely. When the spent fuel charge is released into the exhaust system, it is still hot enough to burn. The KCA System allows extra air into the exhaust system so that the spent fuel charge can continue to burn. This continued burning action tends to burn up a great deal of the normally unburned gases, as well as changing a significant portion of the poisonous carbon monoxide into harmless carbon dioxide.

### **Air Suction Valves -**

The air suction valve is essentially a check valve which allows fresh air to

flow only from the air cleaner into the exhaust port. Any air that has passed the air suction valve is prevented from returning. Inspect the air suction valves in accordance with the Periodic Maintenance Chart. Also, inspect the air suction valves whenever stable idling cannot be obtained, engine power is greatly reduced, or there are abnormal engine noise.

Air suction valve removal and inspection should be done by an authorized Kawasaki dealer.

## Air Cleaner

A clogged air cleaner restricts the engine's air intake, increasing fuel consumption, reducing engine power, and causing spark plug fouling.

The air cleaner element must be replaced in accordance with the Periodic Maintenance Chart. In dusty, rainy, or on muddy conditions, the air cleaner element should be serviced more frequently than the recommended interval by an authorized Kawasaki dealer.

### *Element Removal*

- Remove the bolts of the air cleaner cover located on the right-side of the engine.

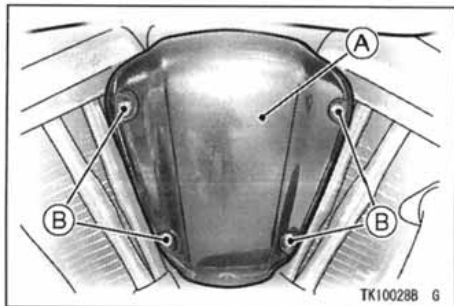

**A. Air Cleaner Cover**

**B. Bolt**

- Remove the air cleaner screw and the air cleaner. If any part of the element is damaged, the element must be replaced.

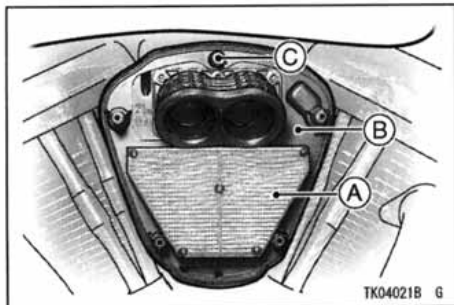

A. Air Cleaner Element  
C. Screw

B. Air Cleaner

**⚠ WARNING**

If dirt or dust is allowed to pass through into the fuel injection system, the throttle may become stuck, possibly causing accident.

**CAUTION**

If dirt gets through into the engine, excessive engine wear and possibly engine damage will occur.

**NOTE**

○ *Element installation is performed in the reverse order of removal.*

## Throttle Control System

Check the throttle grip play, in accordance with the Periodic Maintenance Chart, and adjust the throttle grip play.

### Throttle Grip -

The throttle grip controls the butterfly valves in the throttle body. If the throttle grip has excessive play due to either cable stretch or maladjustment, it will cause a delay in throttle response, especially at low engine speed. Also, the throttle valve may not open fully at full throttle. On the other hand, if the throttle grip has no play, the throttle will be hard to control, and idle speed will be erratic.

#### Inspection

- Check that there is 2 ~ 3 mm (0.08 ~ 0.12 in.) throttle grip play when

lightly turning the throttle grip back and forth.

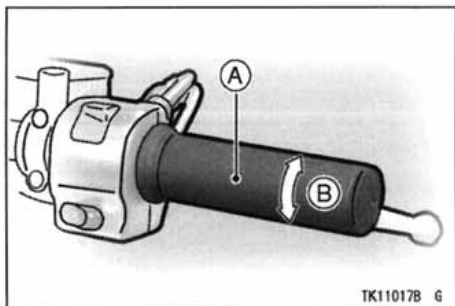

A. Throttle Grip

B. 2 ~ 3 mm (0.08 ~ 0.12 in.)

- If there is improper play, adjust it.

#### Adjustment

- Loosen the locknuts at the upper ends of the throttle cables, and screw both throttle cable adjusting nuts in completely so as to give the throttle grip plenty of play.

## 84 MAINTENANCE AND ADJUSTMENT

- Turn out the decelerator cable adjusting nut until there is no play when the throttle grip is completely closed. Tighten the locknut.

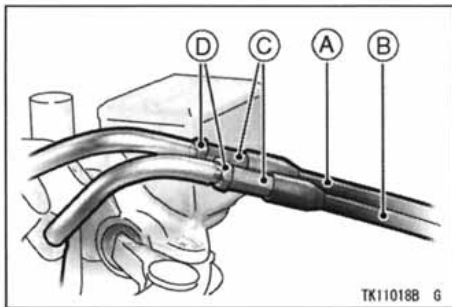

- A. Accelerator Cable    C. Adjusting Nuts  
B. Decelerator Cable    D. Locknuts

- Turn the accelerator cable adjusting nut until 2 ~ 3 mm (0.08 ~ 0.12 in.) of

throttle grip play is obtained. Tighten the locknut.

- If the throttle cables cannot be adjusted by using the cable adjusting nuts at the upper ends of the throttle cables, further adjustment of the throttle cables should be done by an authorized Kawasaki dealer.

### **⚠ WARNING**

**Operation with improperly adjusted, incorrectly routed, or damaged cables could result in an unsafe riding condition.**

## Idle Speed

The idle adjustment should be performed in accordance with the Periodic Maintenance Chart or whenever the idle speed is disturbed.

The following procedure covers the idle speed adjustment.

### Adjustment

- Start the engine, and warm it up thoroughly.
- Wait until the idle speed drops before making the following adjustment.
- Adjust the idle speed to 850 ~ 950 r/min (rpm) by turning the idle adjusting screw.

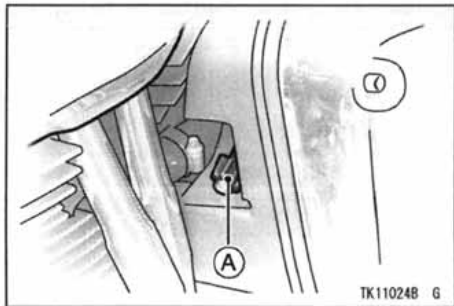

### A. Idle Speed Adjusting Screw

- Open and close the throttle a few times to make sure that the idle speed does not change. Readjust if necessary.
- With the engine idling, turn the handlebar to each side. If handlebar movement changes the idle speed, the throttle cables may be improperly adjusted or incorrectly routed, or they may be damaged. Be sure to correct any of these conditions before riding.

 **WARNING**

**Operation with damaged cables could result in an unsafe riding condition.**

## Clutch

Due to friction plate wear and clutch cable stretch over a long period of use, the clutch must be adjusted in accordance with the Periodic Maintenance Chart.

 **WARNING**

**To avoid a serious burn, never touch a hot engine or an exhaust pipe during clutch adjustment.**

### *Inspection*

- Check that the clutch lever has 2 ~ 3 mm (0.08 ~ 0.12 in.) of play as shown in the figure.



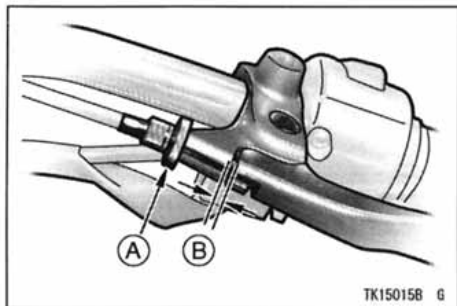

**A. Adjuster**

**B. 2 ~ 3 mm (0.08 ~ 0.12 in.)**

If the play is incorrect, adjust the lever play as follows.

#### *Adjustment*

- Turn the adjuster so that the clutch lever will have 2 ~ 3 mm (0.08 ~ 0.12 in.) of play.

### **⚠ WARNING**

Be sure the upper end of the clutch outer cable is fully seated in its fitting, or it could slip into place later, creating enough cable play to prevent clutch disengagement, resulting in a hazardous riding condition.

- If it cannot be done, use the nuts at the lower end of the clutch cable.

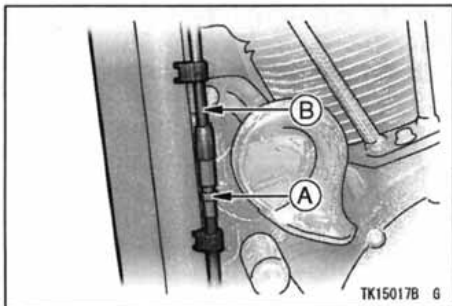

A. Nuts

B. Clutch Cable

### NOTE

- After the adjustment is made, start the engine and check that the clutch does not slip and that it releases properly.
- For minor corrections, use the adjuster at the clutch lever.

## Brakes

### Brake Wear Inspection

In accordance with the Periodic Maintenance Chart, inspect the brakes for wear. For each front and rear disc brake caliper, if the thickness of either pad is less than 1 mm (0.04 in), replace both pads in the caliper as a set. Pad replacement should be done by an authorized Kawasaki dealer.

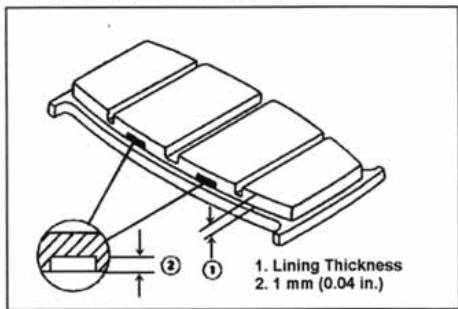

**Disc Brake Fluid -**

In accordance with the Periodic Maintenance Chart, inspect the brake fluid level in both the front and rear brake fluid reservoirs and change the brake fluid. The brake fluid should also be changed if it becomes contaminated with dirt or water.

*Fluid Requirement*

Use heavy-duty brake fluid only from a container marked DOT4 .

**CAUTION**

**Do not spill brake fluid onto any painted surface.**

**Do not use fluid from a container that has been left open or that has been unsealed for a long time.**

**Check for fluid leakage around the fittings.**

**Check brake hose for damage.**

*Fluid Level Inspection*

- The brake fluid level in the front brake fluid reservoir must be kept above the line (lower level line) next to the gauge and that in the rear brake fluid reservoir (located near the brake pedal) must be kept between the upper and lower level lines (reservoirs held horizontal).

## 90 MAINTENANCE AND ADJUSTMENT

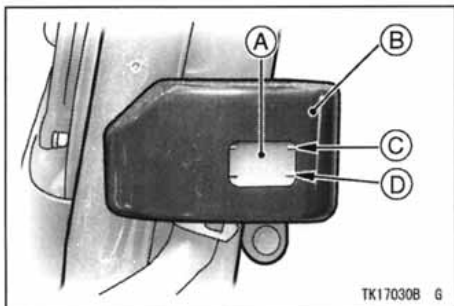

- A. Rear Brake Fluid Reservoir
- B. Cover
- C. Upper Level Line
- D. Lower Level Line

- If the fluid level in either reservoir is lower than the lower level line, check for fluid leaks in the brake lines, and fill the reservoir to the upper level line. Inside the front brake fluid reservoir is a stepped line showing the upper level line. For the rear reservoir, take off the bolt and remove the cover from the reservoir.

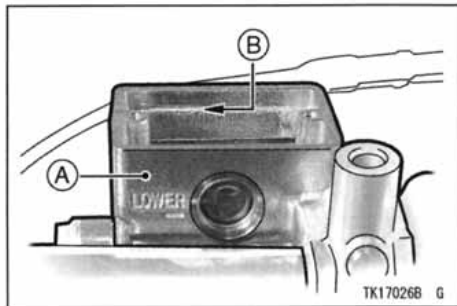

- A. Front Brake Fluid Reservoir
- B. Upper Level Line

### WARNING

**Do not mix two brands of brake fluid. Change the brake fluid in the brake line completely if the brake fluid must be refilled but the type and brand of the brake fluid that is already in the reservoir are unidentified.**

**NOTE**

- *First, tighten until slight resistance is felt indicating that the cap is seated on the reservoir body; then, tighten the cap an additional 1/6 turn while holding the brake fluid reservoir body.*

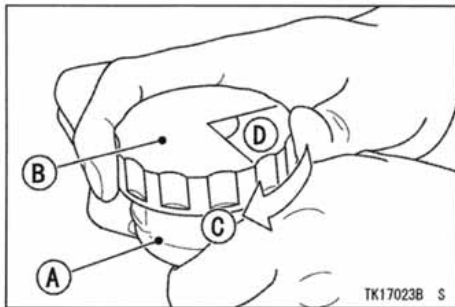

A. Reservoir  
B. Cap

C. Clockwise  
D. 1/6 turn

*Fluid Change*

Have the brake fluid changed by an authorized Kawasaki dealer.

**Front and Rear Brakes -**

Disc and disc pad wear is automatically compensated for and has no effect on the brake lever or pedal action. So there are no parts that require adjustment on the front and rear brakes.

**⚠ WARNING**

**If the brake lever or pedal feels mushy when it is applied, there might be air in the brake lines or the brake may be defective. Since it is dangerous to operate the motorcycle under such conditions, have the brake checked immediately by an authorized Kawasaki dealer.**

### Brake Light Switches

When either the front or rear brake is applied, the brake light goes on. The front brake light switch requires no adjustment, but the rear brake light switch should be adjusted in accordance with the Periodic Maintenance Chart.

#### *Inspection*

- Turn the ignition key to "ON".
- The brake light should go on when the front brake is applied.
- If it does not, ask your authorized Kawasaki dealer to inspect the front brake light switch.
- Check the operation of the rear brake light switch by depressing the brake pedal. The brake light should go on after about 10 mm (0.4 in.) of pedal travel.

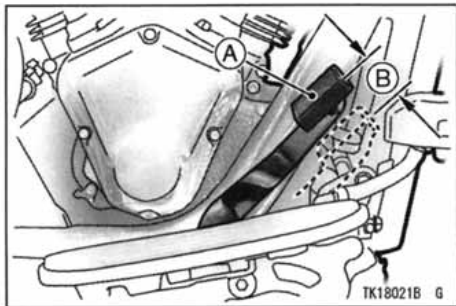

A. Brake Pedal

B. 10 mm (0.4 in.)

- If it does not, adjust the rear brake light switch.

#### *Adjustment*

- To adjust the rear brake light switch, move the switch up or down by turning the adjusting nut.

**CAUTION**

To avoid damaging the electrical connections inside the switch, be sure that the switch body does not turn during adjustment.

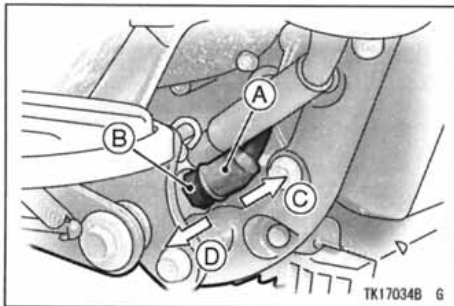

- A. Rear Brake Light Switch
- B. Adjusting Nut
- C. Lights sooner.
- D. Lights later.

**Rear Shock Absorbers**

The rear shock absorber can be adjusted by changing the spring preload and rebound damping force for various riding and loading conditions.

**CAUTION**

Do not force the rebound damping force adjusters beyond the fully seated position, or the adjusting mechanism may be damaged.

*Spring Preload Adjustment*

The rear shock absorber spring preload adjustment should be done with a suitable tool by an authorized Kawasaki dealer.

*Rebound Damping Force Adjustment*

The rebound damping force adjuster is located at the lower end of the rear shock absorber.

## 94 MAINTENANCE AND ADJUSTMENT

- Turn the rebound damping force adjuster all the way clockwise with a screwdriver to make the damping force greatest.
- Turn the adjuster counterclockwise to decrease damping force.

The standard setting positions of the rebound damping force adjuster for an average-build rider of 68 kg (150 lb) with no passenger and no accessories are as follows:

Rebound Damping Force Adjuster	6th click
-----------------------------------	-----------

\*: out from the fully seated position

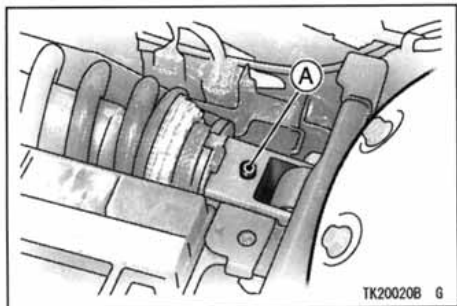

A. Adjuster



## Wheels

Tubeless tires are installed on the wheels of this motorcycle. The indications of TUBELESS on the tire side wall and the rim show that the tire and rim are specially designed for tubeless use.

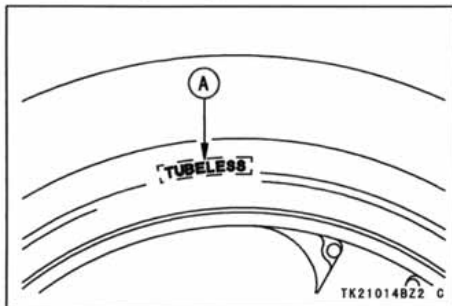

A. TUBELESS Mark

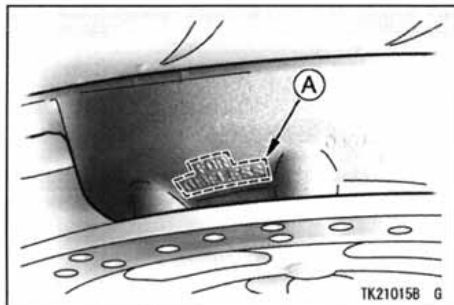

A. TUBELESS Mark

The tire and rim form a leakproof unit by making airtight contacts at the tire chamfers and the rim flanges instead of using an inner tube.

**⚠ WARNING**

The tires, rims, and air valves on this motorcycle are designed only for tubeless type wheels. The recommended standard tires, rims, and air valves must be used for replacement.

Do not install tube-type tires on tubeless rims. The beads may not seat properly on the rim causing tire deflation.

Do not install a tube inside a tubeless tire. Excessive heat build-up may damage the tube causing tire deflation.

**Tires -***Payload and Tire Pressure*

Failure to maintain proper inflation pressures or observe payload limits for your tires may adversely affect handling and performance of your motorcycle and can result in loss of control. The maximum recommended load in addition to vehicle weight is 185 kg (408 lb), including rider, passenger, baggage, and accessories.

- Remove the air valve cap.
- Check the tire pressure often, using an accurate gauge.
- Make sure that the air valve cap is securely installed.

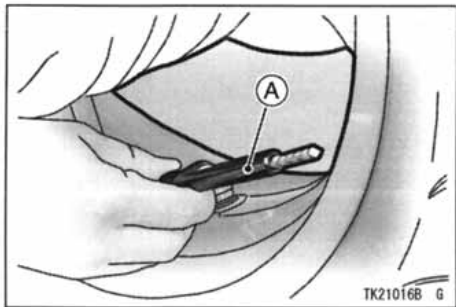

A. Tire Pressure Gauge

### NOTE

- Measure the tire pressure when the tires are cold (that is, when the motorcycle has not been ridden more than a mile during the past 3 hours).
- Tire pressure is affected by changes in ambient temperature and altitude, and so the tire pressure should be

*checked and adjusted when your riding involves wide variations in temperature or altitude.*

### Tire Air Pressure (when cold)

Front	Up to 185 kg Load (408 lb)	250 kPa (2.5 kgf/cm <sup>2</sup> , 36 psi)
Rear	Up to 185 kg Load (408 lb)	290 kPa (2.9 kgf/cm <sup>2</sup> , 42 psi)

### Tire Wear, Damage

As the tire tread wears down, the tire becomes more susceptible to puncture and failure. An accepted estimate is that 90% of all tire failures occur during the last 10% of tread life (90% worn). So it is false economy and unsafe to use the tires until they are bald.

- In accordance with the Periodic Maintenance Chart, measure the

## 98 MAINTENANCE AND ADJUSTMENT

depth of the tread with a depth gauge, and replace any tire that has worn down to the minimum allowable tread depth.

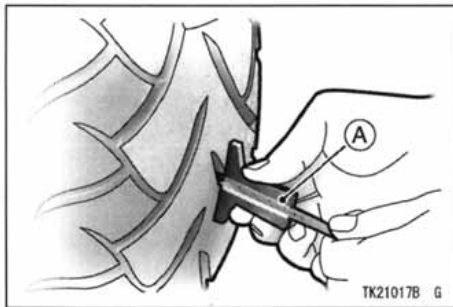

A. Tire Depth Gauge

### Minimum Tread Depth

Front	_____	1 mm (0.04 in.)
Rear	Under 130 km/h (80 mph)	2 mm (0.08 in.)
	Over 130 km/h (80 mph)	3 mm (0.12 in.)

- Visually inspect the tire for cracks and cuts, replacing the tire in case of bad damage. Swelling or high spots indicate internal damage, requiring tire replacement.
- Remove any imbedded stones or other foreign particles from the tread.

### NOTE

- *Have the wheel balance inspected whenever a new tire is installed.*

**⚠ WARNING**

To ensure safe handling and stability, use only the recommended standard tires for replacement, inflated to the standard pressure.

Tires that have been punctured and repaired do not have the same capabilities as undamaged tires. Do not exceed 100 km/h (60 mph) within 24 hours after repair, and 180 km/h (110 mph) at any time after that.

**NOTE**

- *When operating on public roadways, keep maximum speed under traffic law limits.*

**Standard Tire (Tubeless)**

Front	150/80R16 M/C 71V • BRIDGESTONE "BT020 F RADIAL" • DUNLOP "D251F"
Rear	200/60R16 M/C 79V • BRIDGESTONE "BT020 R RADIAL" • DUNLOP "D251"

**⚠ WARNING**

**Use the same manufacturer's tires on both front and rear wheels.**

 **WARNING**

**New tires are slippery and may cause loss of control and injury. A break-in period of 160 km (100 miles) is necessary to establish normal tire traction. During break-in, avoid sudden and maximum braking and acceleration, and hard cornering.**

**Battery**

The battery installed in this vehicle is a sealed type, and the sealing strip should not be removed at any time after the specified electrolyte has been installed in the battery for initial service. It is not necessary to check the battery electrolyte level or add distilled water.

However, in order to maximize battery life and ensure that it will provide the power needed to start the motorcycle you must properly maintain the battery's charge. When used regularly, the charging system in the motorcycle helps keep the battery fully charged. If the motorcycle is only used occasionally or for short periods of time, the battery is more likely to discharge.

Due to their internal composition, batteries continually self discharge. The discharge rate depends on the type of battery and ambient temperature. As temperatures rise, so does

the discharge rate. Every 15°C (27°F) doubles the rate.

Electrical accessories, such as digital clocks and computer memory, also draw current from the battery even when the key is switched off. Combine such "key-off" draws with hot temperature, and a battery can go from fully charged to completely discharged in a matter of days.

Self-discharge		
Temperature	Approx. Number of Days From 100% Charged to 100% discharged	
	Lead -Antimony	Lead -Calcium
	Battery	Battery
40°C (104°F)	100 Days	300 Days
25°C (77°F)	200 Days	600 Days
0°C (32°F)	550 Days	950 Days

Current Drain		
Dis-charging Ampere	Days from 100% Charged to 50% Discharged	Days from 100 % Charged to 100 % Discharged
7 mA	60 Days	119 Days
10 mA	42 Days	83 Days
15 mA	28 Days	56 Days
20 mA	21 Days	42 Days
30 mA	14 Days	28 Days

In extremely cold weather the fluid in an inadequately charged battery can easily freeze, which can crack the case and buckle the plates. A fully charged battery can withstand sub-freezing temperatures with no damage.

### Battery Sulfation

A common cause of battery failure is sulfation.

Sulfation occurs when the battery is left in a discharged condition for an extended time. Sulfate is a normal by product of the chemical reactions within a battery. But when continuous discharge allows the sulfate to crystallize in the cells, the battery plates become permanently damaged and will not hold a charge. Battery failure due to sulfation is not warrantable.

### Battery Maintenance

It is the owner's responsibility to keep the battery fully charged. Failure to do so can lead to battery failure and leave you stranded.

If you are riding your vehicle infrequently, inspect the battery voltage weekly using a voltmeter. If it drops below 12.6 volts, the battery should be



charged using an appropriate charger (check with your Kawasaki dealer). If you will not be using the motorcycle for longer than two weeks, the battery should be charged using an appropriate charger. Do not use an automotive-type quick charger that may overcharge the battery and damage it.

### **Kawasaki-recommended chargers are**

OptiMate III

Yuasa 1.5 Amp Automatic charger

Battery Mate 150-9

If the above chargers are not available, use equivalent one.

For more details, ask your Kawasaki dealer.

### **Battery Charging**

- Remove the battery from the motorcycle (see Battery Removal).

- Attach the leads from the charger and charge the battery at a rate that is 1/10th of the battery capacity. For example, the charging rate for a 10 Ah battery would be 1.0 ampere.
- The charger will keep the battery fully charged until you are ready to re-install the battery in the motorcycle (see Battery Installation).

### **CAUTION**

**Never remove the sealing stirp, or the battery can be damaged. Do not install a conventional battery in this vehicle, or the electrical system cannot work properly.**

## 104 MAINTENANCE AND ADJUSTMENT

### NOTE

○ If you charge the sealed battery, never fail to observe the instructions shown on the label on the battery.

#### *Battery Removal*

- Remove the rider's and passenger's seat.
- Remove the battery holder bolts and take off the battery holder.
- Remove the battery cover screw and take off the battery cover.
- Disconnect the wires from the battery, first from the (-) terminal and then the (+) terminal.

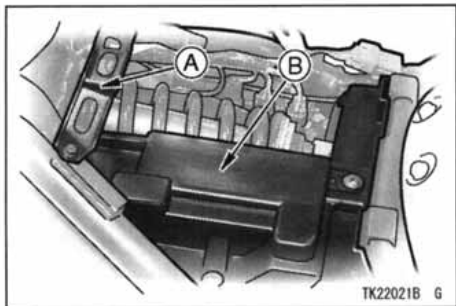

**A. Battery Holder**  
**B. Battery Cover**

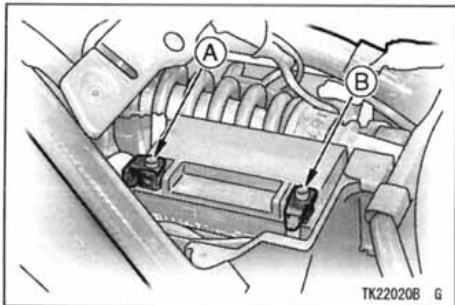

- A. (+) Terminal  
B. (-) Terminal

- Pull the battery out of the case.
- Clean the battery using a solution of baking soda and water. Be sure that the wire connections are clean.

#### *Battery Installation*

- Connect the capped (red) wire to the (+) terminal, and then connect the capped (black) wire to the (-) terminal.

### NOTE

- *Install the battery in the reverse order of the Battery Removal.*

### CAUTION

**Installing the (-) cable to the (+) terminal of the battery or the (+) cable to the (-) terminal of the battery can seriously damage the electrical system.**

### NOTE

- *When installing the battery, the speedometer needle may momentarily point to the last reading. If the battery is disconnected while the meter needle is moving, the needle will stop on its way, but will normally return when the battery is connected again.*

## 106 MAINTENANCE AND ADJUSTMENT

- Put a light coat of grease on the terminals to prevent corrosion.
- Cover the terminals with its protective cap.
- Install the battery holder, and tighten the battery holder bolts.
- Reinstall the parts removed.

## Headlight Beam

### *Horizontal Adjustment*

The headlight beam is adjustable horizontally. If not properly adjusted horizontally, the beam will point to one side rather than straight ahead.

- Turn the horizontal adjusting screw on the headlight rim in or out until the beam points straight ahead.

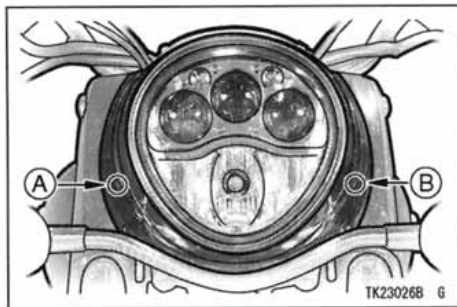

**A. Vertical Adjusting Screw**

**B. Horizontal Adjusting Screw**

### *Vertical Adjustment*

The headlight beam is adjustable vertically. If adjusted too low, neither low nor high beam will illuminate the road far enough ahead. If adjusted too high, the high beam will fail to illuminate the road close ahead, and the low beam will blind oncoming drivers.

- Turn the vertical adjusting screw on the headlight rim in or out to adjust the headlight vertically.

### **NOTE**

- *On high beam, the brightest point should be slightly below horizontal with the motorcycle on its wheels and the rider seated. Adjust the headlight to the proper angle according to local regulations.*

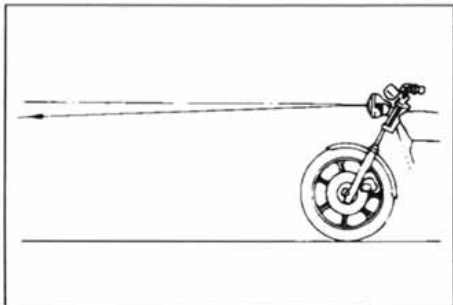

### Fuses

The fuses are arranged in the junction box located behind left side cover.

The main fuse is mounted on the starter relay. The Electronic Control Unit (ECU) fuse is located behind the left side cover. If a fuse fails during operation, inspect the electrical system to determine the cause, and then replace it with a new fuse of proper amperage.

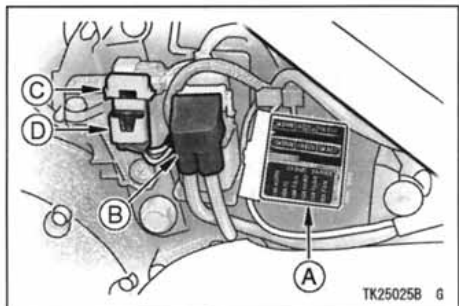

A. Junction Box

B. Main Fuse

C. ECU Fuse

D. Spare Fuse

### WARNING

**Do not use any substitute for the standard fuse.**

**Replace the blown fuse with a new one of the correct capacity as specified on the junction box and main fuse.**

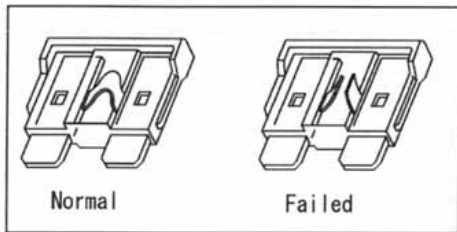

## Cleaning Your Motorcycle

### *General Precautions*

Frequent and proper care of your Kawasaki motorcycle will enhance its appearance, optimize overall performance, and extend its useful life. Covering your motorcycle with a high quality, breathable motorcycle cover will help protect its finish from harmful UV rays, pollutants, and reduce the amount of dust reaching its surfaces.

- Be sure the engine and exhaust are cool before washing.
- Avoid applying degreaser to seals, brake pads, and tires.
- Always use non-abrasive wax and cleaner/polisher.
- Avoid all harsh chemicals, solvents, detergents, and household cleaning products such as ammonia-based window cleaners.

## 110 MAINTENANCE AND ADJUSTMENT

- Gasoline, brake fluid, and coolant will damage the finish of painted and plastic surfaces: wash them off immediately.
- Avoid wire brushes, steel wool, and all other abrasive pads or brushes.
- Use care when washing the headlight cover, and the plastic parts as they can easily be scratched.
- Avoid using pressure washers; water can penetrate seals and electrical components and damage your motorcycle.
- Avoid spraying water in delicate areas such as in air intakes, fuel system, brake components, electrical components, muffler outlets, and fuel tank openings.
- Mix a mild neutral detergent (designed for motorcycles or automobiles) and water in bucket. Use a soft cloth or sponge to wash your motorcycle. If needed, use a mild degreaser to remove any oil or grease build up.
- After washing, rinse your motorcycle thoroughly with clean water to remove any residue (residue from the detergent can damage parts of your motorcycle).
- Use a soft cloth to dry your motorcycle. As you dry, inspect your motorcycle for chips and scratches. Do not let the water air dry as this can damage the painted surfaces.
- Start the engine and let it idle for several minutes. The heat from the engine will help dry moist areas.
- Carefully ride your motorcycle at a slow speed and apply the brakes several times. This helps dry the

### *Washing Your Motorcycle*

- Rinse your bike with cold water from a garden hose to remove any loose dirt.



brakes and restores them to normal operating performance.

### NOTE

- *After riding in an area where the roads are salted or near the ocean, immediately wash your motorcycle with cold water. Do not use warm water as it accelerates the chemical reaction of the salt. After drying, apply a corrosion protection spray on all metal and chrome surfaces to prevent corrosion.*

#### *Painted Surfaces*

After washing your motorcycle, coat painted surfaces, both metal and plastic, with a commercially available motorcycle/automotive wax. Wax should be applied once every three months or

as conditions require. Avoid surfaces with "satin" or "flat" finishes. Always use nonabrasive products and apply them according to the instructions on the container.

#### *Plastic Parts*

After washing use a soft cloth to gently dry plastic parts. When dry, treat the headlight lens and non-painted plastic parts with an approved plastic cleaner/polisher product.

**CAUTION**

Plastic parts may deteriorate and break if they come in contact with chemical substances or household cleaning products such as gasoline, brake fluid, window cleaners, thread-locking agents, or other harsh chemicals. If a plastic part comes in contact with any harsh chemical substance, wash it off immediately with water and a mild neutral detergent, and then inspect for damage. Avoid using abrasive pads or brushes to clean plastic parts, as they will damage the part's finish.

*Chrome and Aluminum*

Chrome and uncoated aluminum parts can be treated with a chrome/aluminum polish. Coated aluminum should be washed with a mild neutral detergent and finished with a spray polish. Aluminum wheels, both painted and unpainted can be cleaned with special non-acid based wheel spray cleaners.

*Leather, Vinyl, and Rubber*

If your motorcycle has leather accessories, special care must be taken. Use a leather cleaner/treatment to clean and care for leather accessories. Washing leather parts with detergent and water will damage them, shortening their life.

Vinyl parts should be washed with the rest of the motorcycle, then treated with a vinyl treatment.

The sidewalls of tires and other rubber components should be treated with a rubber protectant to help prolong their useful life.

 **WARNING**

**Special care must be taken not to get any rubber protectant on the tire's tread surface when treating tires. This may decrease the tire's ability to maintain contact with the road surface causing the rider to lose control.**

---

## Storage

---

### Preparation for Storage:

- Clean the entire vehicle thoroughly.
- Run the engine for about five minutes to warm the oil, shut it off and drain the engine oil.

 **WARNING**

**Motor oil is a toxic substance. Dispose of used oil properly. Contact your local authorities for approved disposal methods or possible recycling.**

- Put in fresh engine oil.
- Empty the fuel from the fuel tank by the pump or siphon.

 **WARNING**

**Gasoline is extremely flammable and can be explosive under certain conditions. Turn the ignition key to “OFF”. Do not smoke. Make sure the area is well ventilated and free from any source of flame or sparks; this includes any appliance with a pilot light.**

**Gasoline is a toxic substance. Dispose of gasoline properly. Contact your local authorities for approved disposal methods.**

- Empty the fuel system by running the engine at idle speed until all fuel in the fuel system is used up (If left in for a long time, the fuel will break down and clog the fuel system).
- Remove the spark plugs and spray fogging oil directly into each cylinder. Push the starter button for a few seconds to coat the cylinder walls. Install the spark plugs.

 **WARNING**

**Do not lean over the engine when performing this procedure. An air/oil mist may be forcibly ejected from the spark plug holes and could get into your eyes. If you do get some in your eyes, wash your eyes immediately with liberal amounts of clean, fresh water. Consult a physician as soon as possible.**

## 116 STORAGE

- Reduce tire pressure by about 20%.
- Set the motorcycle on a box or stand so that both wheels are raised off the ground. (If this cannot be done, put boards under the front and rear wheels to keep dampness away from the tire rubber.)
- Spray oil on all unpainted metal surfaces to prevent rusting. Avoid getting oil on rubber parts or in the brakes.
- Lubricate all the cables.
- Remove the battery, and store it where it will not be exposed to direct sunlight, moisture, or freezing temperatures. During storage it should be given a slow charge (one ampere or less) about once a month. Keep the battery well charged especially during cold weather.
- Tie plastic bags over the mufflers to prevent moisture from entering.
- Put a cover over the motorcycle to keep dust and dirt from collecting on it.

### **Preparation after Storage:**

- Remove the plastic bags from the mufflers.
- Install the battery in the motorcycle and charge the battery if necessary.
- Make sure the spark plugs are tight.
- Fill the fuel tank with fuel.
- Check all the points listed in the Daily Safety Checks section.
- Lubricate the points listed in the General Lubrication section.

---

## Environmental Protection

---

To protect our environment, properly discard used batteries, tires, engine oil, or other vehicle components that you might dispose of in the future. Consult your authorized Kawasaki dealer or local environmental waste agency for their proper disposal procedure.

## Location of Labels

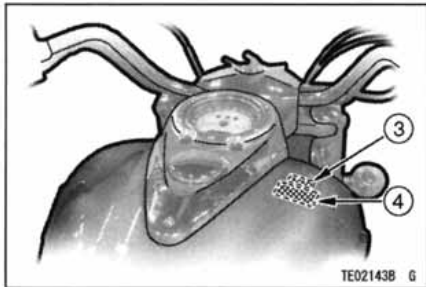
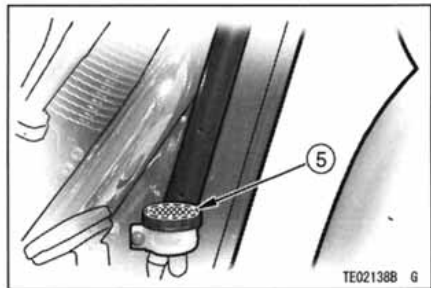
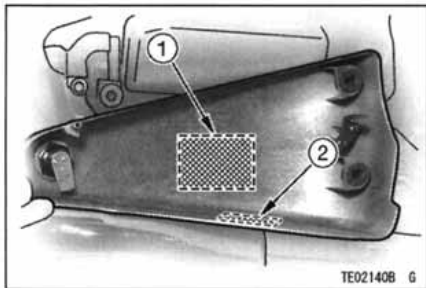

1. Daily Safety Checks
2. Engine Oil and Oil Filter
3. Fuel Caution
4. Unleaded Gasoline
5. Brake Fluid (Rear)



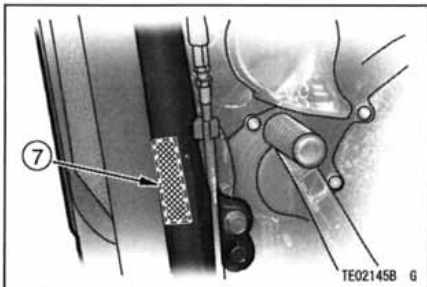
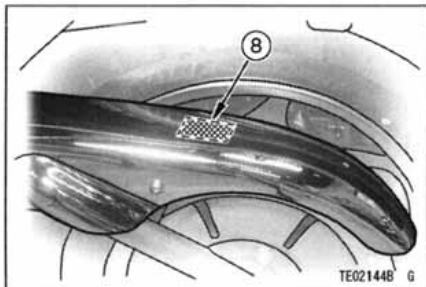
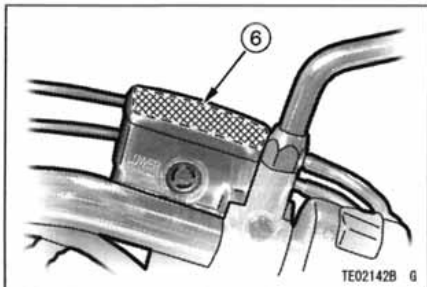

- 6. Brake Fluid (Front)**
- \*7. Noise Test Information**
- \*8. Tire and Load Data**

**\*: only on Australia model**

## 120 LOCATION OF LABELS

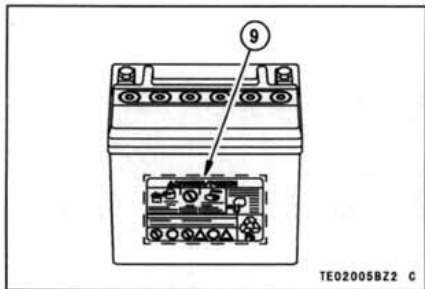

### 9. Battery Poison/Danger

(1)

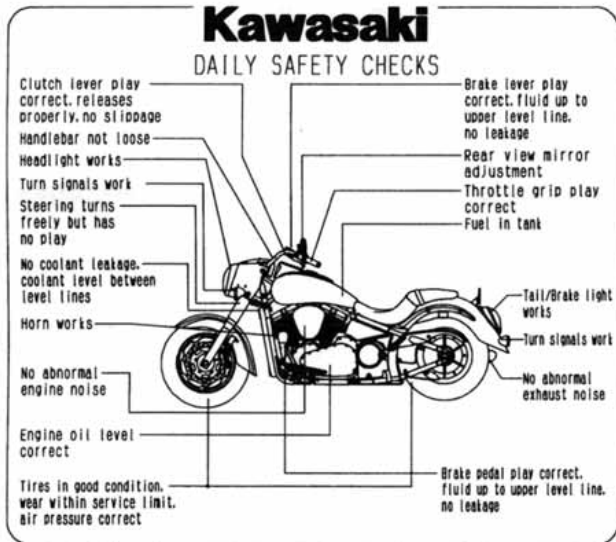

## 122 LOCATION OF LABELS

(2)

### ENGINE OIL AND OIL FILTER

Engine Oil Change--when filter is not removed: 4.4 liters(4.7 US qt)

when filter is removed: 4.6 liters(4.9 US qt)

Engine Oil Type: API SE, SF or SG

: API SH or SJ with JASO MA

SAE 10W-40

See Owner's Manual for engine oil / filter information and change intervals.

TE03282BN8 C

(3)

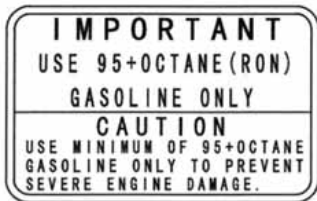

TE03124BN9 C

(4)



TE03123BN9 C

(5)

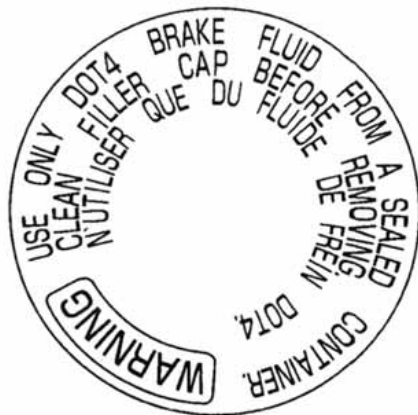

TE03097B S

## 124 LOCATION OF LABELS

(6)

USE ONLY DOT4 BRAKE FLUID  
FROM A SEALED CONTAINER.  
CLEAN FILLER CAP BEFORE  
REMOVING.

**-WARNING-**

N'UTILISER QUE DU FLUIDE  
DE FREIN DOT4.

TE03104BN9 C

(7)

STATIONARY NOISE TEST INFORMATION  
TESTED 92.0 dB(A) AT 2550 r/min  
SILENCING SYSTEM : KAWASAKI HEAVY  
INDUSTRIES, LTD.  
IDENTIFICATION :

TE03284BN9 C

(8)

TIRE AND LOAD DATA						
The stability and handling characteristics of this motorcycle could become unsafe by the use of improper tire inflation pressures, overworn tires, unsuitable replacement tires, or overloading. When tire tread wears down to the limit, replace the tire with only the standard tire. Maintain the inflation pressure specified.						
	Air pressure (Cold)		Size & Make Type (Tubeless Tire)		Minimum Tread Depth	
Front	Up to 185 kg Load (408 lbs)	250 kPa <sup>2</sup> (2.5kgf/cm, 36psi)	BRIDGESTONE 150/60R16W/C 71V BT020 F RADIAL	DUNLOP 150/60R16W/C 71V D251F	1 mm (0.04 in)	
		290 kPa <sup>2</sup> (2.9kgf/cm, 42psi)	BRIDGESTONE 200/60R16W/C 79V BT020 R RADIAL	DUNLOP 200/60R16W/C 79V D251		
Rear					Up to 120 km/h (80MPH)	2 mm (0.08 in)
					Over 120 km/h (80MPH)	3 mm (0.12 in)

TE03278BN8 C

(9)

<b>! DANGER/POISON</b>			
 <p><b>SHIELD EYES</b> EXPLOSIVE GASES CAN CAUSE BLINDNESS OR INJURY</p>	 <p><b>NO</b> • SPARKS • FLAMES • SMOKING</p>	 <p><b>SULFURIC ACID</b> CAN CAUSE BLINDNESS OR SEVERE BURNS</p>	<p><b>FLUSH EYES IMMEDIATELY WITH WATER</b></p>  <p><b>GET MEDICAL HELP FAST</b></p>
<b>KEEP OUT OF REACH OF CHILDREN</b>			
			
			 <p><b>LEAD</b>      <b>RETURN</b></p> <p><b>RECYCLE</b></p>
<p><b>IN U.S.A., DISTR. BY KAWASAKI MOTORS CORP. SANTA ANA, CA. 92799-5252</b></p>			



























# VN2000-A1



\* 9 9 9 8 6 - 1 1 9 5 \*



KAWASAKI HEAVY INDUSTRIES, LTD.  
Consumer Products & Machinery Company

Part No.99986-1195

GB