

VULCAN 900 Custom VN900 Custom

Motorcycle Service Manual



Quick Reference Guide

| | |
|------------------------------------|-----------|
| General Information | 1 |
| Periodic Maintenance | 2 |
| Fuel System (DFI) | 3 |
| Cooling System | 4 |
| Engine Top End | 5 |
| Clutch | 6 |
| Engine Lubrication System | 7 |
| Engine Removal/Installation | 8 |
| Crankshaft/Transmission | 9 |
| Wheels/Tires | 10 |
| Final Drive | 11 |
| Brakes | 12 |
| Suspension | 13 |
| Steering | 14 |
| Frame | 15 |
| Electrical System | 16 |
| Appendix | 17 |

This quick reference guide will assist you in locating a desired topic or procedure.

- Bend the pages back to match the black tab of the desired chapter number with the black tab on the edge at each table of contents page.
- Refer to the sectional table of contents for the exact pages to locate the specific topic required.



VULCAN 900 Custom
VN900 Custom

Motorcycle Service Manual

All rights reserved. No parts of this publication may be reproduced, stored in a retrieval system, or transmitted in any form or by any means, electronic mechanical photocopying, recording or otherwise, without the prior written permission of Quality Assurance Division/Motorcycle & Engine Company/Kawasaki Heavy Industries, Ltd., Japan.

No liability can be accepted for any inaccuracies or omissions in this publication, although every possible care has been taken to make it as complete and accurate as possible.

The right is reserved to make changes at any time without prior notice and without incurring an obligation to make such changes to products manufactured previously. See your motorcycle dealer for the latest information on product improvements incorporated after this publication.

All information contained in this publication is based on the latest product information available at the time of publication. Illustrations and photographs in this publication are intended for reference use only and may not depict actual model component parts.

EMISSION CONTROL INFORMATION

To protect the environment in which we all live, Kawasaki has incorporated crankcase emission (1) and exhaust emission (2) control systems in compliance with applicable regulations of the United States Environmental Protection Agency and California Air Resources Board. Additionally, Kawasaki has incorporated an evaporative emission control system (3) in compliance with applicable regulations of the California Air Resources Board on vehicles sold in California only.

1. Crankcase Emission Control System

This system eliminates the release of crankcase vapors into the atmosphere. Instead, the vapors are routed through an oil separator to the inlet side of the engine. While the engine is operating, the vapors are drawn into combustion chamber, where they are burned along with the fuel and air supplied by the fuel injection system.

2. Exhaust Emission Control System

This system reduces the amount of pollutants discharged into the atmosphere by the exhaust of this motorcycle. The fuel, ignition, and exhaust systems of this motorcycle have been carefully designed and constructed to ensure an efficient engine with low exhaust pollutant levels.

The exhaust system of this model motorcycle manufactured primarily for sale in California includes a catalytic converter system.

3. Evaporative Emission Control System

Vapors caused by fuel evaporation in the fuel system are not vented into the atmosphere. Instead, fuel vapors are routed into the running engine to be burned, or stored in a canister when the engine is stopped. Liquid fuel is caught by a vapor separator and returned to the fuel tank.

The Clean Air Act, which is the Federal law covering motor vehicle pollution, contains what is commonly referred to as the Act's "tampering provisions".

"Sec. 203(a) The following acts and the causing thereof are prohibited...

(3)(A) for any person to remove or render inoperative any device or element of design installed on or in a motor vehicle or motor vehicle engine in compliance with regulations under this title prior to its sale and delivery to the ultimate purchaser, or for any manufacturer or dealer knowingly to remove or render inoperative any such device or element of design after such sale and delivery to the ultimate purchaser.

(3)(B) for any person engaged in the business of repairing, servicing, selling, leasing, or trading motor vehicles or motor vehicle engines, or who operates a fleet of motor vehicles knowingly to remove or render inoperative any device or element of design installed on or in a motor vehicle or motor vehicle engine in compliance with regulations under this title following its sale and delivery to the ultimate purchaser..."

NOTE

○The phrase "remove or render inoperative any device or element of design" has been generally interpreted as follows.

1. Tampering does not include the temporary removal or rendering inoperative of devices or elements of design in order to perform maintenance.
2. Tampering could include.
 - a. Maladjustment of vehicle components such that the emission standards are exceeded.
 - b. Use of replacement parts or accessories which adversely affect the performance or durability of the motorcycle.
 - c. Addition of components or accessories that result in the vehicle exceeding the standards.
 - d. Permanently removing, disconnecting, or rendering inoperative any component or element of design of the emission control systems.

WE RECOMMEND THAT ALL DEALERS OBSERVE THESE PROVISIONS OF FEDERAL LAW, THE VIOLATION OF WHICH IS PUNISHABLE BY CIVIL PENALTIES NOT EXCEEDING \$10 000 PER VIOLATION.

TAMPERING WITH NOISE CONTROL SYSTEM PROHIBITED

Federal law prohibits the following acts or the causing thereof: (1) The removal or rendering inoperative by any person other than for purposes of maintenance, repair, or replacement, of any device or element of design incorporated into any new vehicle for the purpose of noise control prior to its sale or delivery to the ultimate purchaser or while it is in use, or (2) the use of the vehicle after such device or element of design has been removed or rendered inoperative by any person.

Among those acts presumed to constitute tampering are the acts listed below.

- Replacement of the original exhaust system or muffler with a component not in compliance with Federal regulations.
- Removal of the muffler(s) or any internal portion of the muffler(s).
- Removal of the air box or air box cover.
- Modifications to the muffler(s) or air inlet system by cutting, drilling, or other means if such modifications result in increased noise levels.

Foreword

This manual is designed primarily for use by trained mechanics in a properly equipped shop. However, it contains enough detail and basic information to make it useful to the owner who desires to perform his own basic maintenance and repair work. A basic knowledge of mechanics, the proper use of tools, and workshop procedures must be understood in order to carry out maintenance and repair satisfactorily. Whenever the owner has insufficient experience or doubts his ability to do the work, all adjustments, maintenance, and repair should be carried out only by qualified mechanics.

In order to perform the work efficiently and to avoid costly mistakes, read the text, thoroughly familiarize yourself with the procedures before starting work, and then do the work carefully in a clean area. Whenever special tools or equipment are specified, do not use makeshift tools or equipment. Precision measurements can only be made if the proper instruments are used, and the use of substitute tools may adversely affect safe operation.

For the duration of the warranty period, we recommend that all repairs and scheduled maintenance be performed in accordance with this service manual. Any owner maintenance or repair procedure not performed in accordance with this manual may void the warranty.

To get the longest life out of your vehicle.

- Follow the Periodic Maintenance Chart in the Service Manual.
- Be alert for problems and non-scheduled maintenance.
- Use proper tools and genuine Kawasaki Motorcycle parts. Special tools, gauges, and testers that are necessary when servicing Kawasaki motorcycles are introduced by the Service Manual. Genuine parts provided as spare parts are listed in the Parts Catalog.
- Follow the procedures in this manual carefully. Don't take shortcuts.
- Remember to keep complete records of maintenance and repair with dates and any new parts installed.

How to Use This Manual

In this manual, the product is divided into its major systems and these systems make up the manual's chapters. The Quick Reference

Guide shows you all of the product's system and assists in locating their chapters. Each chapter in turn has its own comprehensive Table of Contents.

For example, if you want ignition coil information, use the Quick Reference Guide to locate the Electrical System chapter. Then, use the Table of Contents on the first page of the chapter to find the Ignition Coil section.

Whenever you see symbols, heed their instructions! Always follow safe operating and maintenance practices.

DANGER

DANGER indicates a hazardous situation which, if not avoided, will result in death or serious injury.

WARNING

WARNING indicates a hazardous situation which, if not avoided, could result in death or serious injury.

NOTICE

NOTICE is used to address practices not related to personal injury.

This manual contains four more symbols which will help you distinguish different types of information.

NOTE

○ *NOTE* indicates information that may help or guide you in the operation or service of the vehicle.

- Indicates a procedural step or work to be done.
- Indicates a procedural sub-step or how to do the work of the procedural step it follows. It also precedes the text of a NOTE.
- ★ Indicates a conditional step or what action to take based on the results of the test or inspection in the procedural step or sub-step it follows.

In most chapters an exploded view illustration of the system components follows the Table of Contents. In these illustrations you will find the instructions indicating which parts require specified tightening torque, oil, grease or a locking agent during assembly.

LIST OF ABBREVIATIONS

| | | | |
|------|---------------------------|-----|--------------------------|
| A | ampere(s) | L | liter(s) |
| ABDC | after bottom dead center | lb | pound(s) |
| AC | alternating current | m | meter(s) |
| ATDC | after top dead center | min | minute(s) |
| BBDC | before bottom dead center | N | newton(s) |
| BDC | bottom dead center | Pa | pascal(s) |
| BTDC | before top dead center | PS | horsepower |
| °C | degree(s) Celsius | psi | pound(s) per square inch |
| DC | direct current | r | revolution |
| F | farad(s) | rpm | revolution(s) per minute |
| °F | degree(s) Fahrenheit | TDC | top dead center |
| ft | foot, feet | TIR | total indicator reading |
| g | gram(s) | V | volt(s) |
| h | hour(s) | W | watt(s) |
| in. | inch(es) | Ω | ohm(s) |

COUNTRY AND AREA CODES

| | | | |
|-----|-------------|--------|--|
| AT | Austria | GB | United Kingdom |
| AU | Australia | PH | Philippines |
| BR | Brazil | SEA-B1 | Southeast Asia B1 (with Evaporative Emission Control System) |
| CA | Canada | SEA-B3 | Southeast Asia B3 |
| CAL | California | TH | Thailand |
| CH | Switzerland | US | United States |
| DE | Germany | WVTA | Whole Vehicle Type Approval |
| EUR | Europe | | |

General Information

Table of Contents

| | |
|-----------------------------|------|
| Before Servicing | 1-2 |
| Model Identification..... | 1-7 |
| General Specifications..... | 1-9 |
| Unit Conversion Table | 1-13 |

1-2 GENERAL INFORMATION

Before Servicing

Before starting to perform an inspection service or carry out a disassembly and reassembly operation on a motorcycle, read the precautions given below. To facilitate actual operations, notes, illustrations, photographs, cautions, and detailed descriptions have been included in each chapter wherever necessary. This section explains the items that require particular attention during the removal and reinstallation or disassembly and reassembly of general parts.

Especially note the following:

Battery Ground

Before completing any service on the motorcycle, disconnect the battery cables from the battery to prevent the engine from accidentally turning over. Disconnect the ground cable (–) first and then the positive (+). When completed with the service, first connect the positive (+) cable to the positive (+) terminal of the battery then the negative (–) cable to the negative terminal.

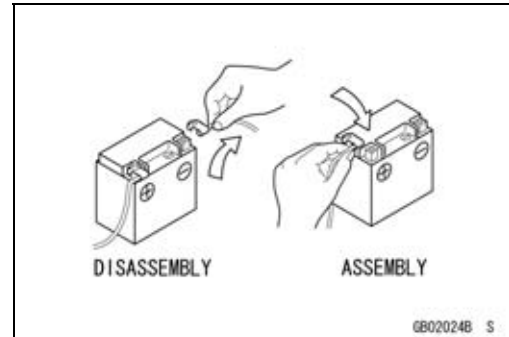

Edges of Parts

Lift large or heavy parts wearing gloves to prevent injury from possible sharp edges on the parts.

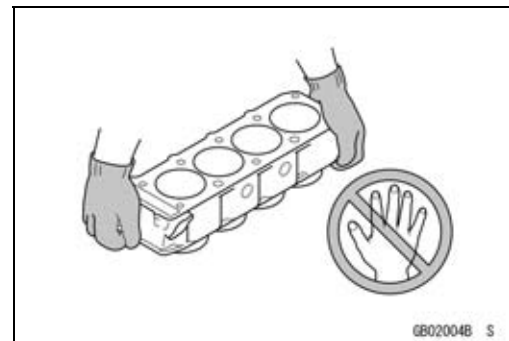

Solvent

Use a high flash-point solvent when cleaning parts. High flash-point solvent should be used according to directions of the solvent manufacturer.

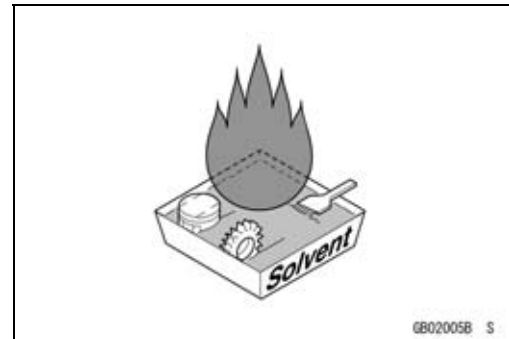

Cleaning Vehicle before Disassembly

Clean the vehicle thoroughly before disassembly. Dirt or other foreign materials entering into sealed areas during vehicle disassembly can cause excessive wear and decrease performance of the vehicle.

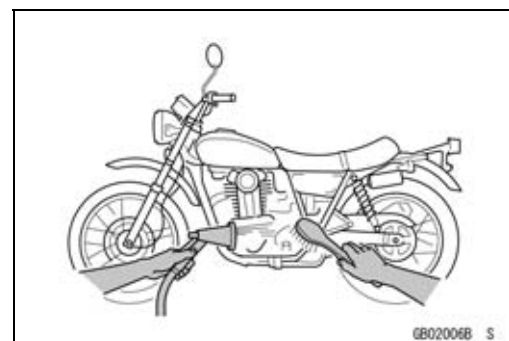

Before Servicing

Arrangement and Cleaning of Removed Parts

Disassembled parts are easy to confuse. Arrange the parts according to the order the parts were disassembled and clean the parts in order prior to assembly.

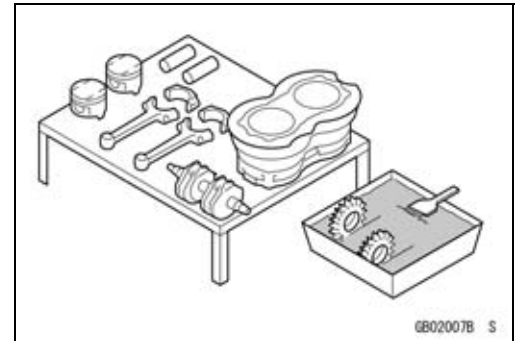

Storage of Removed Parts

After all the parts including subassembly parts have been cleaned, store the parts in a clean area. Put a clean cloth or plastic sheet over the parts to protect from any foreign materials that may collect before re-assembly.

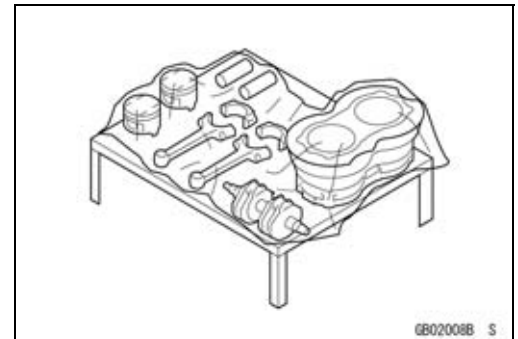

Inspection

Reuse of worn or damaged parts may lead to serious accident. Visually inspect removed parts for corrosion, discoloration, or other damage. Refer to the appropriate sections of this manual for service limits on individual parts. Replace the parts if any damage has been found or if the part is beyond its service limit.

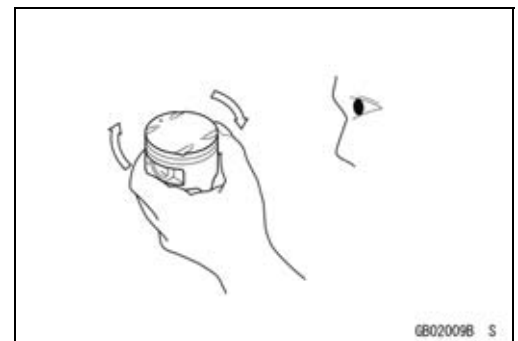

Replacement Parts

Replacement parts must be KAWASAKI genuine or recommended by KAWASAKI. Gaskets, O-rings, oil seals, grease seals, circlips, cotter pins or self-locking nuts must be replaced with new ones whenever disassembled.

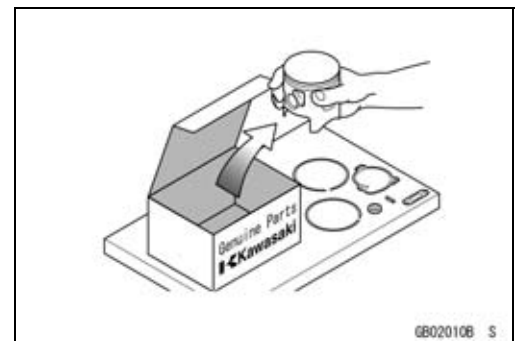

Assembly Order

In most cases assembly order is the reverse of disassembly, however, if assembly order is provided in this Service Manual, follow the procedures given.

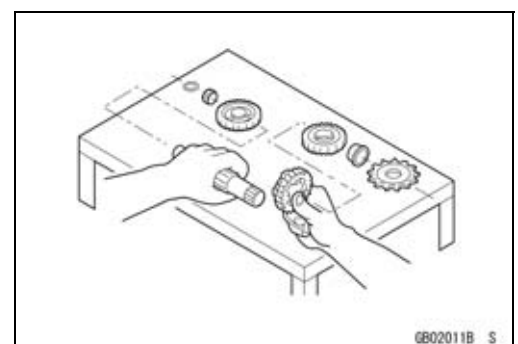

1-4 GENERAL INFORMATION

Before Servicing

Tightening Sequence

Generally, when installing a part with several bolts, nuts, or screws, start them all in their holes and tighten them to a snug fit. Then tighten them according to the specified sequence to prevent case warpage or deformation which can lead to malfunction. Conversely when loosening the bolts, nuts, or screws, first loosen all of them by about a quarter turn and then remove them. If the specified tightening sequence is not indicated, tighten the fasteners alternating diagonally.

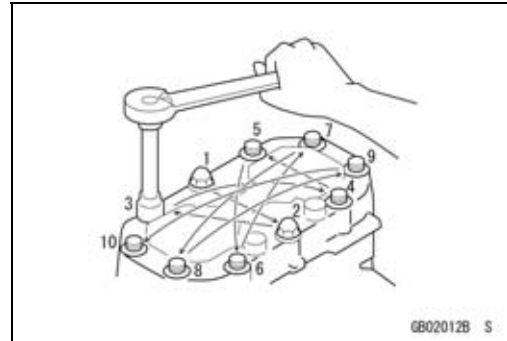

Tightening Torque

Incorrect torque applied to a bolt, nut, or screw may lead to serious damage. Tighten fasteners to the specified torque using a good quality torque wrench. Often, the tightening sequence is followed twice-initial tightening and final tightening with torque wrench.

All of the tightening torque values are for use with dry, solvent - cleaned threads unless otherwise indicated. If a fastener which should have dry, clean threads gets contaminated with lubricant, etc., applying even the specified torque could damage it.

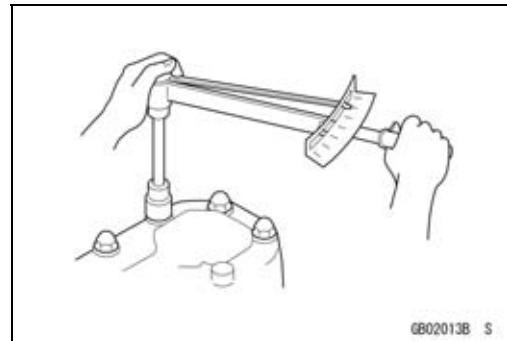

Force

Use common sense during disassembly and assembly, excessive force can cause expensive or hard to repair damage. When necessary, remove screws that have a non-permanent locking agent applied using an impact driver. Use a plastic-faced mallet whenever tapping is necessary.

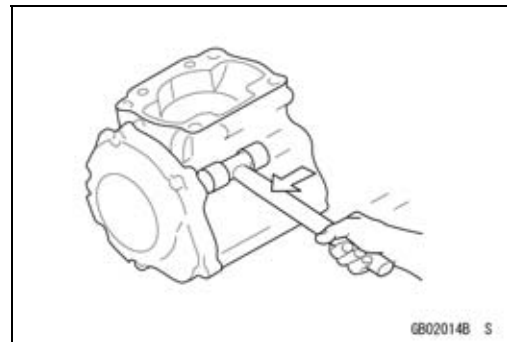

Gasket, O-ring

Hardening, shrinkage, or damage of both gaskets and O-rings after disassembly can reduce sealing performance. Remove old gaskets and clean the sealing surfaces thoroughly so that no gasket material or other material remains. Install new gaskets and replace used O-rings when re-assembling.

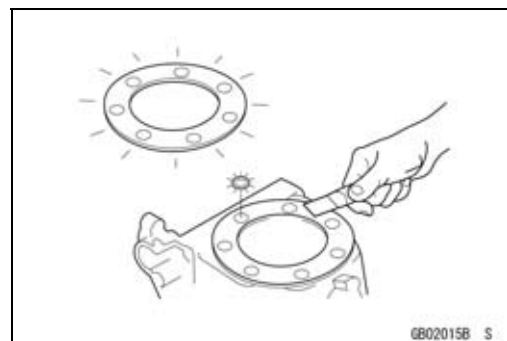

Liquid Gasket, Non-permanent Locking Agent

For applications that require Liquid Gasket or a Non-Permanent Locking Agent, clean the surfaces so that no oil residue remains before applying liquid gasket or non-permanent locking agent. Do not apply them excessively. Excessive application can clog oil passages and cause serious damage.



Before Servicing

Press

For items such as bearings or oil seals that must be pressed into place, apply small amount of oil to the contact area. Be sure to maintain proper alignment and use smooth movements when installing.

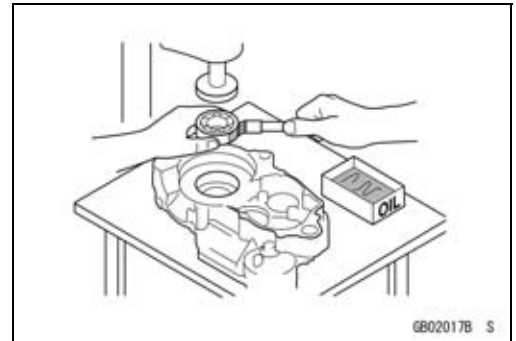

Ball Bearing and Needle Bearing

Do not remove pressed ball or needle unless removal is absolutely necessary. Replace with new ones whenever removed. Press bearings with the manufacturer and size marks facing out. Press the bearing into place by putting pressure on the correct bearing race as shown.

Pressing the incorrect race can cause pressure between the inner and outer race and result in bearing damage.

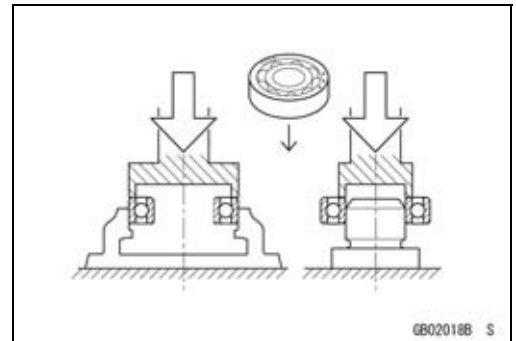

Oil Seal, Grease Seal

Do not remove pressed oil or grease seals unless removal is necessary. Replace with new ones whenever removed. Press new oil seals with manufacture and size marks facing out. Make sure the seal is aligned properly when installing.

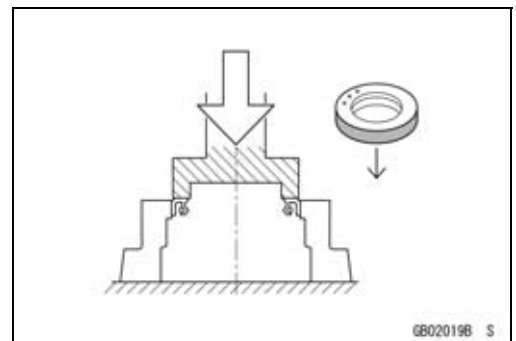

Apply specified grease to the lip of seal before installing the seal.

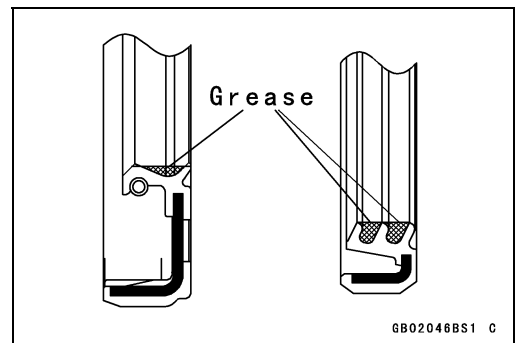

Circlips, Cotter Pins

Replace circlips or cotter pins that were removed with new ones. Take care not to open the clip excessively when installing to prevent deformation.

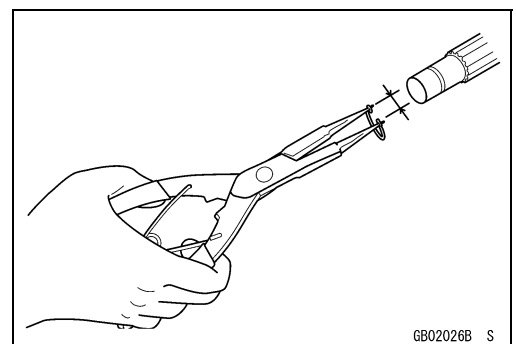

1-6 GENERAL INFORMATION

Before Servicing

Lubrication

It is important to lubricate rotating or sliding parts during assembly to minimize wear during initial operation. Lubrication points are called out throughout this manual, apply the specific oil or grease as specified.

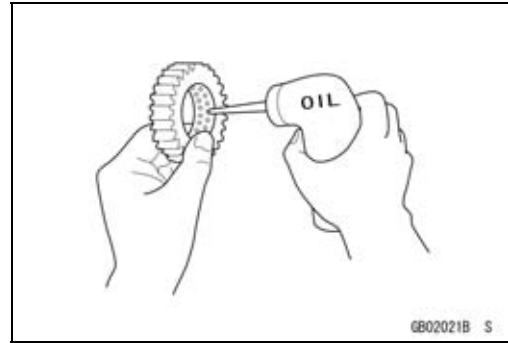

Direction of Engine Rotation

When rotating the crankshaft by hand, the free play amount of rotating direction will affect the adjustment. Rotate the crankshaft to positive direction (clockwise viewed from output side).

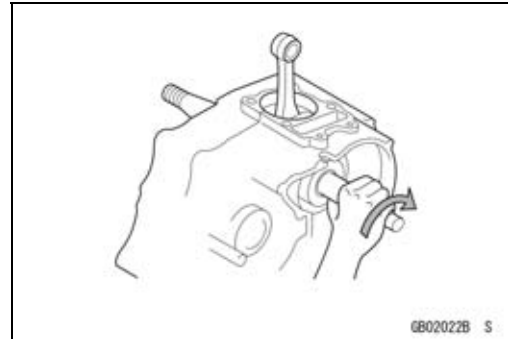

Electrical Leads

A two-color lead is identified first by the primary color and then the stripe color. Unless instructed otherwise, electrical leads must be connected to those of the same color.

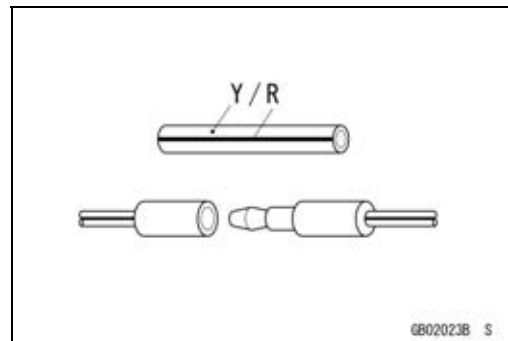

Instrument

Use a meter that has enough accuracy for an accurate measurement. Read the manufacture's instructions thoroughly before using the meter. Incorrect values may lead to improper adjustments.

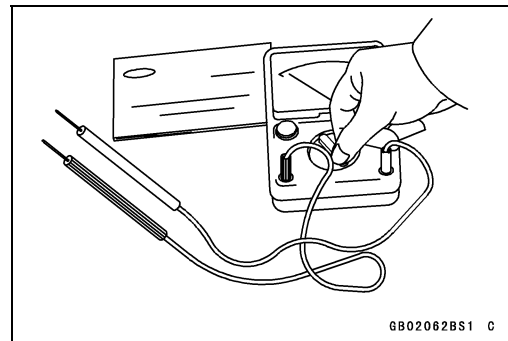

Model Identification

VN900C7 (US and CA) Left Side View



VN900C7 (US and CA) Right Side View



1-8 GENERAL INFORMATION

Model Identification

VN900C7 (EUR and AU) Left Side View



VN900C7 (EUR and AU) Right Side View



Frame Number

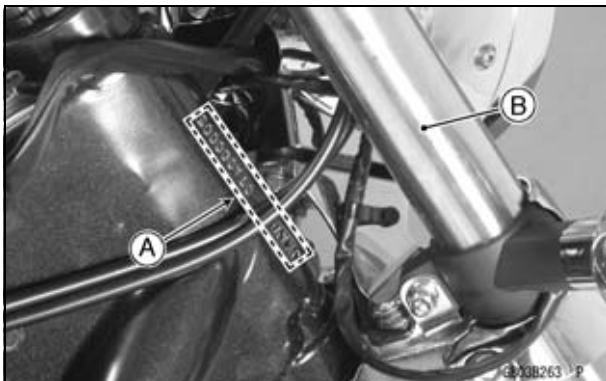

Frame Number [A]
Right Front Fork [B]

Engine Number

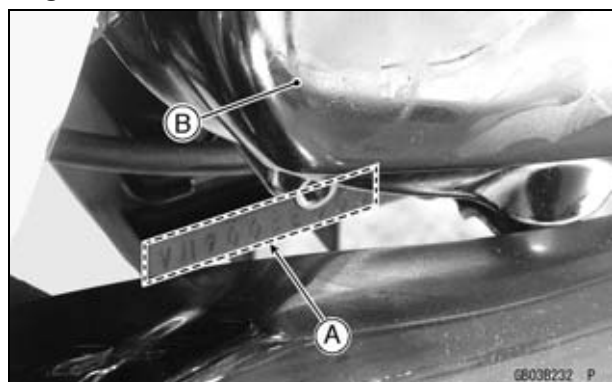

Engine Number [A]
Right Engine Cover [B]

General Specifications

| Items | VN900C7 ~ C8 | VN900C9 ~ CF |
|-------------------------------|--|--|
| Dimensions | | |
| Overall Length | 2 405 mm (94.68 in.) | ← |
| Overall Width | 895 mm (35.24 in.) | ← |
| Overall Height | 1 120 mm (44.09 in.) | ← |
| Wheelbase | 1 645 mm (64.76 in.) | ← |
| Road Clearance | 140 mm (5.51 in.) | ← |
| Seat Height | 685 mm (27.0 in.) | ← |
| Dry Mass | 249 kg (549 lb) (EUR, TH) 250 kg (551 lb) | --- --- |
| Curb Mass: | --- --- | 278 kg (613 lb) (US, CA, CAL, AU) 277 kg (611 lb) |
| Front | 127 kg (280 lb) (EUR, TH) 128 kg (282 lb) --- | ← ← (SEA-B1, PH) (CE: SEA-B3) 128 kg (282 lb) |
| Rear | 150 kg (331 lb) | ← |
| Fuel Tank Capacity | 20 L (5.3 US gal.) | ← |
| Performance | | |
| Minimum Turning Radius | 3.1 m (10.2 ft) | ← (CA ~: BR, EUR, PH, SEA-B1, TH) (CE: SEA-B3) 2.9 m (9.5 ft) |
| Engine | | |
| Type | 4-stroke, SOHC, V2-cylinder | ← |
| Cooling System | Liquid-cooled | ← |
| Bore and Stroke | 88.0 × 74.2 mm (3.46 × 2.92 in.) | ← |
| Displacement | 903 cm ³ (55.1 cu in.) | ← |
| Compression Ratio | 9.5 : 1 | ← |
| Maximum Horsepower | 37 kW (50 PS) @5 700 r/min (rpm) (CA) (CAL) (US) --- (SEA-B1) 38 kW (52 PS) @5 500 r/min (rpm) | ← ← (SEA-B1) (CE: SEA-B3) 37 kW (50 PS) @5 700 r/min (rpm) (CD ~: EUR) 35 kW (48 PS) @5 700 r/min (rpm) |
| Maximum Torque | 78 N·m (8.0 kgf·m, 58 ft·lb) @3 700 r/min (rpm) (CA) (CAL) (US) --- | ← ← (CD ~: EUR) 77 N·m (7.9 kgf·m, 57 ft·lb) |
| Carburetion System | DFI (Digital Fuel Injection) System | ← |
| Fuel Type: | | |
| Minimum Octane Rating: | | |
| Research Octane Number (RON) | 91 | ← |
| Antiknock Index (RON + MON)/2 | 87 | ← |
| Starting System | Electric starter | ← |

1-10 GENERAL INFORMATION

General Specifications

| Items | VN900C7 ~ C8 | VN900C9 ~ CF |
|-----------------|---|--|
| Ignition System | Battery and coil (transistorized) | ← |
| Timing Advance | Electronically advanced (digital igniter) | ← |
| Ignition Timing | From 0° BTDC @1 000 r/min (rpm) to 53° BTDC @5 800 r/min (rpm) (AU, EUR, TH) From 3.5° BTDC @1 000 r/min (rpm) to 53° BTDC @5 800 r/min (rpm) (C8:CAL, SEA-B1) From 3° BTDC @1 000 r/min (rpm) to 39° BTDC @5 400 r/min (rpm) | From 3.5° BTDC @1 000 r/min (rpm) to 53° BTDC @5 800 r/min (rpm) (US, CA, CAL) From 3° BTDC @1 000 r/min (rpm) to 39° BTDC @5 400 r/min (rpm) |

General Specifications

| Items | VN900C7 ~ CF |
|--|--|
| Spark Plug Cylinder Numbering Method Firing Order Valve Timing: Inlet: Open Close Duration Exhaust: Open Close Duration Lubrication System Engine Oil: Type Viscosity Capacity | NGK CPR7EA-9 Front to Rear, 1-2 1-2 40° BTDC 40° ABDC 260° 55° BBDC 25° ATDC 260° Forced lubrication (wet sump) API SG, SH, SJ, SL or SM with JASO MA, MA1 or MA2 SAE 10W-40 3.7 L (3.9 US qt) |
| Drive Train Primary Reduction System: Type Reduction Ratio Clutch Type Transmission: Type Gear Ratios: 1st 2nd 3rd 4th 5th Final Drive System: Type Reduction Ratio Overall Drive Ratio | Chain 2.184 (83/38) Wet multi disc 5-speed, constant mesh, return shift 2.786 (39/14) 1.889 (34/18) 1.360 (34/25) 1.107 (31/28) 0.963 (26/27) Belt 2.063 (66/32) 4.338 at Top gear |
| Frame Type Caster (Rake Angel) Trail Front Tire: Type Size Rim Size | Tubular, double cradle 33° 182 mm (7.09 in.) Tubeless 80/90-21 M/C 48H J21 M/C × MT 2.15 |

1-12 GENERAL INFORMATION

General Specifications

| Items | VN900C7 ~ CF |
|---|--|
| Rear Tire: Type Size Rim Size Front Suspension: Type Wheel Travel Rear Suspension: Type Wheel Travel Brake Type: Front Rear | Tubeless 180/70-15 M/C 76H J15 M/C × MT 4.50 Telescopic fork 150 mm (5.90 in.) Swingarm (uni-trak) 103 mm (4.06 in.) Single disc Single disc |
| Electrical Equipment Battery Headlight: Type Bulb Brake/Tail Light Alternator: Type Maximum Output | 12 V 10 Ah (10 HR) Semi-sealed beam 12 V 60/55W (quartz-halogen) 12 V 21/5 W Three-phase AC 14 V-32 A @5 000 r/min (rpm) |

Specifications are subject to change without notice, and may not apply to every country.

Unit Conversion Table

Prefixes for Units:

| Prefix | Symbol | Power |
|--------|--------|-------------|
| mega | M | × 1 000 000 |
| kilo | k | × 1 000 |
| centi | c | × 0.01 |
| milli | m | × 0.001 |
| micro | μ | × 0.000001 |

Units of Mass:

| | | | | |
|----|---|---------|---|----|
| kg | × | 2.205 | = | lb |
| g | × | 0.03527 | = | oz |

Units of Volume:

| | | | | |
|----|---|---------|---|------------|
| L | × | 0.2642 | = | gal (US) |
| L | × | 0.2200 | = | gal (IMP) |
| L | × | 1.057 | = | qt (US) |
| L | × | 0.8799 | = | qt (IMP) |
| L | × | 2.113 | = | pint (US) |
| L | × | 1.816 | = | pint (IMP) |
| mL | × | 0.03381 | = | oz (US) |
| mL | × | 0.02816 | = | oz (IMP) |
| mL | × | 0.06102 | = | cu in. |

Units of Force:

| | | | | |
|---|---|--------|---|----|
| N | × | 0.1020 | = | kg |
| N | × | 0.2248 | = | lb |

| | | | | |
|----|---|-------|---|----|
| kg | × | 9.807 | = | N |
| kg | × | 2.205 | = | lb |

Units of Length:

| | | | | |
|----|---|---------|---|------|
| km | × | 0.6214 | = | mile |
| m | × | 3.281 | = | ft |
| mm | × | 0.03937 | = | in. |

Units of Torque:

| | | | | |
|-----|---|--------|---|-------|
| N·m | × | 0.1020 | = | kgf·m |
| N·m | × | 0.7376 | = | ft·lb |
| N·m | × | 8.851 | = | in·lb |

| | | | | |
|-------|---|-------|---|-------|
| kgf·m | × | 9.807 | = | N·m |
| kgf·m | × | 7.233 | = | ft·lb |
| kgf·m | × | 86.80 | = | in·lb |

Units of Pressure:

| | | | | |
|-----|---|---------|---|---------------------|
| kPa | × | 0.01020 | = | kgf/cm ² |
| kPa | × | 0.1450 | = | psi |
| kPa | × | 0.7501 | = | cmHg |

| | | | | |
|---------------------|---|-------|---|-----|
| kgf/cm ² | × | 98.07 | = | kPa |
| kgf/cm ² | × | 14.22 | = | psi |
| cmHg | × | 1.333 | = | kPa |

Units of Speed:

| | | | | |
|------|---|--------|---|-----|
| km/h | × | 0.6214 | = | mph |
|------|---|--------|---|-----|

Units of Power:

| | | | | |
|----|---|-------|---|----|
| kW | × | 1.360 | = | PS |
| kW | × | 1.341 | = | HP |

| | | | | |
|----|---|--------|---|----|
| PS | × | 0.7355 | = | kW |
| PS | × | 0.9863 | = | HP |

Units of Temperature:

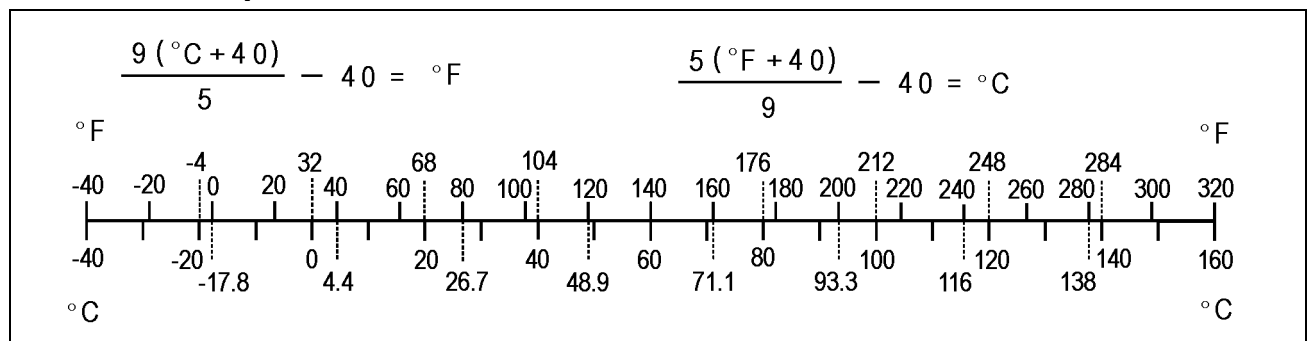

Periodic Maintenance

Table of Contents

| | | | |
|--------------------------------------|------|------------------------------------|------|
| Periodic Maintenance Chart | 2-2 | Brake Fluid Level Inspection..... | 2-32 |
| Torque and Locking Agent..... | 2-6 | Brake Pad Wear Inspection | 2-33 |
| Specifications | 2-11 | Brake Light Switch Operation | |
| Special Tools | 2-13 | Inspection..... | 2-33 |
| Periodic Maintenance Procedures..... | 2-14 | Suspensions | 2-34 |
| Fuel System (DFI)..... | 2-14 | Front Forks/Rear Shock Absorber | |
| Throttle Control System | | Operation Inspection | 2-34 |
| Inspection..... | 2-14 | Front Fork Oil Leak Inspection.... | 2-35 |
| Idle Speed Inspection | 2-14 | Rear Shock Absorber Oil Leak | |
| Idle Speed Adjustment..... | 2-15 | Inspection..... | 2-35 |
| Fuel Hose Inspection (fuel leak, | | Swingarm Pivot Lubrication | 2-35 |
| damage, installation condition).. | 2-15 | Rocker Arm Operation Inspection | 2-35 |
| Evaporative Emission Control | | Tie-Rod Operation Inspection | 2-35 |
| System Inspection (CAL, TH, | | Uni-trak Linkage Lubrication | 2-36 |
| SEA-B1)..... | 2-16 | Steering System | 2-36 |
| Evaporative Emission Control | | Steering Play Inspection | 2-36 |
| System Inspection..... | 2-16 | Steering Play Adjustment..... | 2-36 |
| Cooling System..... | 2-17 | Steering Stem Bearing | |
| Coolant Level Inspection..... | 2-17 | Lubrication..... | 2-37 |
| Radiator Hose Damage | | Electrical System | 2-38 |
| and Installation Condition | | Spark Plug Condition Inspection.. | 2-38 |
| Inspection..... | 2-17 | Lights and Switches Operation | |
| Engine Top End | 2-18 | Inspection..... | 2-38 |
| Air Suction System Damage | | Headlight Aiming Inspection | 2-40 |
| Inspection..... | 2-18 | Sidestand Switch Operation | |
| Valve Clearance Inspection | 2-18 | Inspection..... | 2-41 |
| Valve Clearance Adjustment..... | 2-19 | Engine Stop Switch Operation | |
| Clutch..... | 2-22 | Inspection..... | 2-42 |
| Clutch Operation Inspection..... | 2-22 | Others | 2-43 |
| Wheels/Tires..... | 2-23 | Chassis Parts Lubrication | 2-43 |
| Air Pressure Inspection..... | 2-23 | Bolts, Nuts and Fasteners | |
| Wheel/Tire Damage Inspection.... | 2-23 | Tightness Inspection | 2-44 |
| Tire Tread Wear Inspection..... | 2-23 | Replacement Parts | 2-45 |
| Wheel Bearing Damage | | Air Cleaner Element | |
| Inspection..... | 2-24 | Replacement..... | 2-45 |
| Final Drive..... | 2-25 | Fuel Hose Replacement | 2-46 |
| Belt Deflection Inspection | 2-25 | Coolant Change..... | 2-47 |
| Belt Deflection Adjustment..... | 2-27 | Radiator Hose and O-ring | |
| Wheel Alignment | | Replacement..... | 2-49 |
| Inspection/Adjustment..... | 2-28 | Engine Oil Change..... | 2-50 |
| Belt Wear and Damage | | Oil Filter Replacement | 2-51 |
| Inspection..... | 2-29 | Brake Hose Replacement..... | 2-52 |
| Brake System | 2-31 | Brake Fluid Change | 2-52 |
| Brake Fluid Leak (Brake Hose | | Master Cylinder Rubber Parts | |
| and Pipe) Inspection | 2-31 | Replacement..... | 2-54 |
| Brake Hose and Pipe Damage | | Caliper Rubber Parts | |
| and Installation Condition | | Replacement..... | 2-56 |
| Inspection..... | 2-32 | Spark Plug Replacement..... | 2-59 |
| Brake Operation Inspection | 2-32 | | |

2-2 PERIODIC MAINTENANCE

Periodic Maintenance Chart

The scheduled maintenance must be done in accordance with this chart to keep the motorcycle in good running condition. **The initial maintenance is vitally important and must not be neglected.**

Periodic Inspection

| INSPECTION | FREQUENCY | * ODOMETER READING × 1 000 km (× 1 000 mile) | | | | | | | See Page |
|--|-------------------------------------|--|-------------|-------------|---------------|------------|---------------|--------------|----------|
| | Whichever comes first ↓ Every | 1 (0.6) | 6 (3.75) | 12 (7.5) | 18 (11.25) | 24 (15) | 30 (18.75) | 36 (22.5) | |
| Fuel System | | | | | | | | | |
| Throttle control system (play, smooth return, no drag) - inspect | year | • | | • | | • | | • | 2-14 |
| Idle speed - inspect | | • | | • | | • | | • | 2-14 |
| Fuel leak (fuel hose and pipe) - inspect | year | • | | • | | • | | • | 2-15 |
| Fuel hose and pipe damage - inspect | year | • | | • | | • | | • | 2-15 |
| Fuel hose and pipe installation condition - inspect | year | • | | • | | • | | • | 2-15 |
| Evaporative emission control system function - inspect (CAL, TH, SEA-B1) | | • | • | • | • | • | • | • | 2-16 |
| Cooling System | | | | | | | | | |
| Coolant level - inspect | | • | | • | | • | | • | 2-17 |
| Coolant leak (radiator hose and pipe) - inspect | year | • | | • | | • | | • | 2-17 |
| Radiator hose damage - inspect | year | • | | • | | • | | • | 2-17 |
| Radiator hose installation condition - inspect | year | • | | • | | • | | • | 2-17 |
| Engine Top End | | | | | | | | | |
| Air suction system damage - inspect | | | | • | | • | | • | 2-18 |
| Valve clearance - inspect (US and CA) | | | | | | • | | | 2-18 |
| Valve clearance - inspect (other than US and CA) | | Every 42 000 km (26 250 mile) | | | | | | | 2-18 |
| Clutch | | | | | | | | | |
| Clutch operation (play, disengagement, engagement) - inspect | | • | | • | | • | | • | 2-22 |
| Wheels and Tires | | | | | | | | | |
| Tire air pressure - inspect | year | | | • | | • | | • | 2-23 |
| Wheel/tire damage - inspect | | | | • | | • | | • | 2-23 |
| Tire tread wear, abnormal wear - inspect | | | | • | | • | | • | 2-23 |
| Wheel bearings damage - inspect | year | | | • | | • | | • | 2-24 |

Periodic Maintenance Chart

| INSPECTION | FREQUENCY | * ODOMETER READING × 1 000 km (× 1 000 mile) | | | | | | | See Page |
|---|-------------------------------------|--|-------------|-------------|---------------|------------|---------------|--------------|----------|
| | Whichever comes first ↓ Every | 1 (0.6) | 6 (3.75) | 12 (7.5) | 18 (11.25) | 24 (15) | 30 (18.75) | 36 (22.5) | |
| Final Drive | | | | | | | | | |
| Belt deflection - inspect | | • | • | • | • | • | • | • | 2-25 |
| Belt wear and damage - inspect | | • | • | • | • | • | • | • | 2-29 |
| Brake System | | | | | | | | | |
| Brake fluid leak (brake hose and pipe) - inspect | year | • | • | • | • | • | • | • | 2-31 |
| Brake hose and pipe damage - inspect | year | • | • | • | • | • | • | • | 2-32 |
| Brake hose and pipe installation condition - inspect | year | • | • | • | • | • | • | • | 2-32 |
| Brake operation (effectiveness, play, no drag) - inspect | year | • | • | • | • | • | • | • | 2-32 |
| Brake fluid level - inspect | 6 months | • | • | • | • | • | • | • | 2-32 |
| Brake pad wear - inspect # | | | • | • | • | • | • | • | 2-33 |
| Brake light switch operation - inspect | | • | • | • | • | • | • | • | 2-33 |
| Suspensions | | | | | | | | | |
| Front forks/rear shock absorber operation (damping and smooth stroke) - inspect | | | | • | | • | | • | 2-34 |
| Front forks/rear shock absorber oil leak - inspect | year | | | • | | • | | • | 2-35 |
| Swingarm pivot - lubricate | | | | | | • | | | 2-35 |
| Rocker arm operation - inspect | | | | • | | • | | • | 2-35 |
| Tie-Rod operation - inspect | | | | • | | • | | • | 2-35 |
| Rocker arm bearings - lubricate | | | | | | • | | | 2-36 |
| Tie-Rod bearings - lubricate | | | | | | • | | | 2-36 |
| Steering | | | | | | | | | |
| Steering play - inspect | year | • | | • | | • | | • | 2-36 |
| Steering stem bearings - lubricate | 2 years | | | | | • | | | 2-37 |
| Electrical System | | | | | | | | | |
| Lights and switches operation - inspect | year | | | • | | • | | • | 2-38 |
| Headlight aiming - inspect | year | | | • | | • | | • | 2-40 |
| Sidestand switch operation - inspect | year | | | • | | • | | • | 2-41 |
| Engine stop switch operation - inspect | year | | | • | | • | | • | 2-42 |

2-4 PERIODIC MAINTENANCE

Periodic Maintenance Chart

| INSPECTION | FREQUENCY | * ODOMETER READING | | | | | | | See Page |
|------------------------------------|-------------------------------------|--------------------|-------------|-------------|---------------|------------|---------------|--------------|----------|
| | Whichever comes first ↓ Every | 1 (0.6) | 6 (3.75) | 12 (7.5) | 18 (11.25) | 24 (15) | 30 (18.75) | 36 (22.5) | |
| Others | | | | | | | | | |
| Chassis parts - lubricate | year | | | • | | • | | • | 2-43 |
| Bolts and nuts tightness - inspect | | • | | • | | • | | • | 2-44 |

#: Service more frequently when operating in severe conditions; dusty, wet, muddy, high speed or frequent starting/stopping.

*: For higher odometer readings, repeat at the frequency interval established here.

Periodic Maintenance Chart

Periodic Replacement Parts

| CHANGE/REPLACE ITEM | FREQUENCY | * ODOMETER READING × 1 000 km (× 1 000 mile) | | | | | See Page |
|---|---|--|-------------|------------|--------------|------------|---------------|
| | Whichever comes first ↓ Every | 1 (0.6) | 12 (7.5) | 24 (15) | 36 (22.5) | 48 (30) | |
| Air cleaner element # | | Every 18 000 km (12 000 mile) | | | | | 2-45 |
| Fuel hose | 5 years | | | | | | 2-46 |
| Coolant - change | 3 years | | | | • | | 2-47 |
| Radiator hose and O-ring | 3 years | | | | • | | 2-49 |
| Engine oil # | year | • | • | • | • | • | 2-50 |
| Oil filter | year | • | • | • | • | • | 2-51 |
| Brake hose | 4 years | | | | | | 2-52 |
| Brake fluid - change | 2 years | | | • | | • | 2-52 |
| Rubber parts of master cylinder and caliper | 4 years | | | | | • | 2-54, 2-56 |
| Spark plug | | | • | • | • | • | 2-59 |

#: Service more frequently when operating in severe conditions; dusty, wet, muddy, high speed or frequent starting/stopping.

*: For higher odometer readings, repeat at the frequency interval established here.

2-6 PERIODIC MAINTENANCE

Torque and Locking Agent

The following tables list the tightening torque for the major fasteners requiring use of a non-permanent locking agent or silicone sealant etc. All of the values are for use with dry solvent - cleaned threads unless otherwise indicated.

When checking the tightening torque of the bolts and nuts, first loosen the bolt or nut by half a turn and then tighten to specified torque.

Letters used in the "Remarks" column mean:

L: Apply a non-permanent locking agent.

LG: Apply liquid gasket.

Lh: Left-hand threads

M: Apply molybdenum disulfide grease.

MO: Apply molybdenum disulfide oil solution.

(mixture of the engine oil and molybdenum disulfide grease in a weight ratio 10 : 1)

R: Replacement Parts

S: Follow the specified tightening sequence.

Si: Apply silicone grease (ex. PBC grease).

| Fastener | Torque | | | Remarks |
|--|--------|-------|-----------|---------|
| | N·m | kgf·m | ft·lb | |
| Fuel System (DFI) | | | | |
| Air Cleaner Cover Bolts | 4.9 | 0.50 | 43 in·lb | |
| Air Cleaner Housing Bolts | 9.8 | 1.0 | 87 in·lb | |
| Delivery Joint Bolts | 9.8 | 1.0 | 87 in·lb | L |
| Delivery Joint Bracket Bolt | 9.8 | 1.0 | 87 in·lb | |
| Fuel Level Sensor Mounting Bolts | 6.9 | 0.70 | 61 in·lb | L |
| Fuel Pump Bolts | 9.8 | 1.0 | 87 in·lb | L |
| Inlet Air Pressure Sensor Bolt | 6.9 | 0.70 | 61 in·lb | |
| Inlet Air Temperature Sensor Screw | 1.2 | 0.12 | 11 in·lb | |
| Inlet Manifold Bolts | 9.8 | 1.0 | 87 in·lb | L |
| Oxygen Sensors (Oxygen Sensor Equipped Models) | 25 | 2.5 | 18 | |
| Speed Sensor Mounting Bolt | 9.8 | 1.0 | 87 in·lb | |
| Throttle Body Assy Holder Bolts | 9.8 | 1.0 | 87 in·lb | |
| Vehicle-down Sensor Bolts | 1.0 | 0.10 | 8.9 in·lb | |
| Water Temperature Sensor | 12 | 1.2 | 106 in·lb | |
| Air Cleaner Element Screw (VN900C7 ~ C8) | 2.9 | 0.30 | 26 in·lb | |
| Air Cleaner Element Bolt (VN900C9 ~) | 2.9 | 0.30 | 26 in·lb | |
| Cooling System | | | | |
| Coolant Drain Bolt | 9.8 | 1.0 | 87 in·lb | |
| Radiator Bolts | 6.9 | 0.70 | 61 in·lb | |
| Radiator Fan Bolts | 8.3 | 0.85 | 73 in·lb | |
| Radiator Hose Clamp Screws | 2.0 | 0.20 | 18 in·lb | |
| Radiator Screen Screws | 6.9 | 0.70 | 61 in·lb | |
| Reserve Tank Bolts | 6.9 | 0.70 | 61 in·lb | |
| Thermostat Housing Cover Bolts | 4.9 | 0.50 | 43 in·lb | L |
| Thermostat Housing Cover Bracket Bolt | 6.9 | 0.70 | 61 in·lb | |
| Water Hose Fitting Bolts | 9.8 | 1.0 | 87 in·lb | L |
| Water Pump Impeller Bolt | 9.8 | 1.0 | 87 in·lb | |

Torque and Locking Agent

| Fastener | Torque | | | Remarks |
|-------------------------------------|--------|-------|-----------|---------|
| | N·m | kgf·m | ft·lb | |
| Engine Top End | | | | |
| Camshaft Cap Bolts | 25 | 2.5 | 18 | |
| Camshaft Chain Guide Bolts | 9.8 | 1.0 | 87 in·lb | L |
| Camshaft Chain Tensioner Cap Bolts | 20 | 2.0 | 15 | |
| Camshaft Sprocket Bolts | 49 | 5.0 | 36 | L |
| Cylinder Head Cover Bolts | 12 | 1.2 | 106 in·lb | |
| Cylinder Head Nuts (M10): | | | | |
| First | 20 | 2.0 | 15 | MO, S |
| Final | 49 | 5.0 | 36 | MO, S |
| Cylinder Head Nuts (M8) | 25 | 2.5 | 18 | S |
| Cylinder Head Outer Cover Bolts | 9.8 | 1.0 | 87 in·lb | |
| Exhaust Pipe Cover Bolts | 6.9 | 0.70 | 61 in·lb | |
| Exhaust Pipe Cover Clamp Bolts | 6.9 | 0.70 | 61 in·lb | |
| Exhaust Pipe Holder Nuts | 17 | 1.7 | 12 | |
| Muffler Joint Clamp Bolt | 17 | 1.7 | 12 | |
| Muffler Mounting Bolts | 25 | 2.5 | 18 | |
| Muffler Mounting Nut | 25 | 2.5 | 18 | |
| Plug (PT1/4) | 15 | 1.5 | 11 | L |
| Plug (PT1/2) | 20 | 2.0 | 15 | L |
| Clutch | | | | |
| Clutch Hub Nut | 130 | 13.3 | 96 | MO, R |
| Clutch Spring Bolts | 9.8 | 1.0 | 87 in·lb | |
| Right Engine Cover Bolts | 9.8 | 1.0 | 87 in·lb | L (1) |
| Engine Lubrication System | | | | |
| Engine Oil Drain Plug | 20 | 2.0 | 15 | |
| Oil Filter | 18 | 1.8 | 13 | |
| Oil Filter Plate Bolts | 7.8 | 0.80 | 69 in·lb | |
| Oil Pipe Bolts (Crankcase Inside) | 9.8 | 1.0 | 87 in·lb | L |
| Oil Pipe Bolts (Crankcase Outside) | 9.8 | 1.0 | 87 in·lb | L |
| Oil Pressure Relief Valve | 15 | 1.5 | 11 | L |
| Oil Pressure Switch | 15 | 1.5 | 11 | LG |
| Oil Pressure Switch Adapter | 20 | 2.0 | 15 | |
| Oil Pump Cover Bolts | 9.8 | 1.0 | 87 in·lb | L |
| Oil Pump Drive Chain Guide Bolt | 9.8 | 1.0 | 87 in·lb | L |
| Oil Return Pipe Bolts | 9.8 | 1.0 | 87 in·lb | |
| Oil Screen Plug | 20 | 2.0 | 15 | |
| Engine Removal/Installation | | | | |
| Downtube Bolts | 44 | 4.5 | 32 | |
| Engine Mounting Nuts | 59 | 6.0 | 44 | R |
| Engine Mounting Bracket Bolts (M10) | 44 | 4.5 | 32 | |
| Engine Mounting Bracket Bolts (M8) | 25 | 2.5 | 18 | |
| Crankshaft/Transmission | | | | |
| Balancer Gear Bolt | 69 | 7.0 | 51 | |

2-8 PERIODIC MAINTENANCE

Torque and Locking Agent

| Fastener | Torque | | | Remarks |
|---|--------|-------|-----------|---------|
| | N·m | kgf·m | ft·lb | |
| Balancer Shaft Bearing Stopper Plate Screws | 6.9 | 0.70 | 61 in·lb | |
| Bearing Retainer Bolts | 9.8 | 1.0 | 87 in·lb | L |
| Clamp Mounting Bolts | 9.8 | 1.0 | 87 in·lb | |
| Connecting Rod Big End Bolts | 46 | 4.7 | 34 | MO |
| Crankcase Bolts (M10) | 39 | 4.0 | 29 | S |
| Crankcase Bolts (M6) | 9.8 | 1.0 | 87 in·lb | S |
| Engine Ground Lead Bolt | 9.8 | 1.0 | 87 in·lb | |
| External Shift Mechanism Cover Bolts | 9.8 | 1.0 | 87 in·lb | |
| Gear Set Lever Bolt | 9.8 | 1.0 | 87 in·lb | |
| Neutral Switch | 15 | 1.5 | 11 | |
| Oil Nozzles | 3.9 | 0.40 | 35 in·lb | |
| Primary Gear Bolt | 98 | 10 | 72 | MO |
| Shift Drum Bearing Stopper Bolts | 9.8 | 1.0 | 87 in·lb | L |
| Shift Drum Cam Bolt | 12 | 1.2 | 106 in·lb | L |
| Shift Pedal Bolt and Nut | 39 | 4.0 | 29 | |
| Shift Pedal Clamp Bolt | 12 | 1.2 | 106 in·lb | |
| Shift Rod Locknut (Front) | 9.8 | 1.0 | 87 in·lb | |
| Shift Rod Locknut (Rear) | 9.8 | 1.0 | 87 in·lb | Lh |
| Shift Shaft Return Spring Pin | 29 | 3.0 | 21 | L |
| Starter Motor Clutch Gear Bolt | 69 | 7.0 | 51 | |
| Wheels/Tires | | | | |
| Air Valve Cap | 0.15 | 0.015 | 1.3 in·lb | |
| Air Valve Core | 0.3 | 0.03 | 2.7 in·lb | |
| Air Valve Nuts | 1.5 | 0.15 | 13 in·lb | |
| Front Axle Clamp Bolt | 20 | 2.0 | 15 | |
| Front Axle Nut | 108 | 11.0 | 80 | |
| Rear Axle Nut | 108 | 11.0 | 80 | |
| Final Drive | | | | |
| Drive Belt Guide Bolts | 9.8 | 1.0 | 87 in·lb | |
| Engine Pulley Cover Bolts | 9.8 | 1.0 | 87 in·lb | |
| Engine Pulley Cover Clamp Mounting Bolt | 9.8 | 1.0 | 87 in·lb | |
| Engine Pulley Mounting Nut | 127 | 13.0 | 94 | M |
| Engine Pulley Plate Bolts | 9.8 | 1.0 | 87 in·lb | |
| Rear Pulley Mounting Nuts | 59 | 6.0 | 44 | R |
| Rear Pulley Plate Bolts | 6.9 | 0.70 | 61 in·lb | L |
| Brakes | | | | |
| Bleed Valves | 7.8 | 0.80 | 69 in·lb | |
| Brake Hose Banjo Bolts | 25 | 2.5 | 18 | |
| Brake Lever Pivot Bolt | 1.0 | 0.10 | 9 in·lb | Si |
| Brake Lever Pivot Bolt Locknut | 5.9 | 0.60 | 52 in·lb | |
| Brake Pedal Clamp Bolt | 25 | 2.5 | 18 | |
| Front Brake Disc Mounting Bolts | 27 | 2.8 | 20 | L |
| Front Brake Light Switch Screw | 1.2 | 0.12 | 11 in·lb | |

Torque and Locking Agent

| Fastener | Torque | | | Remarks |
|---|--------|-------|----------|---------|
| | N·m | kgf·m | ft·lb | |
| Front Brake Reservoir Cap Screws | 1.5 | 0.15 | 13 in·lb | |
| Front Caliper Mounting Bolts | 34 | 3.5 | 25 | |
| Front Master Cylinder Clamp Bolts | 8.8 | 0.90 | 78 in·lb | S |
| Rear Brake Disc Mounting Bolts | 27 | 2.8 | 20 | L |
| Rear Caliper Mounting Bolts | 34 | 3.5 | 25 | |
| Rear Master Cylinder Mounting Bolts | 25 | 2.5 | 18 | |
| Rear Master Cylinder Push Rod Locknut | 17 | 1.7 | 12 | |
| Suspension | | | | |
| Front Fork Bottom Allen Bolts | 20 | 2.0 | 15 | L |
| Front Fork Clamp Bolts (Lower) | 34 | 3.5 | 25 | |
| Front Fork Clamp Bolts (Upper) | 20 | 2.0 | 15 | |
| Rear Shock Absorber Nuts | 59 | 6.0 | 44 | R |
| Rocker Arm Pivot Shaft Nut | 59 | 6.0 | 44 | R |
| Swingarm Pivot Shaft Nut | 98 | 10 | 72 | |
| Tie-Rod Nut (Lower) | 59 | 6.0 | 44 | R |
| Tie-Rod Nut (Upper) | 108 | 11.0 | 80 | R |
| Steering | | | | |
| Front Fork Clamp Bolts (Lower) | 34 | 3.5 | 25 | |
| Front Fork Clamp Bolts (Upper) | 20 | 2.0 | 15 | |
| Handlebar Mounting Nuts | 34 | 3.5 | 25 | R |
| Steering Stem Head Nut | 49 | 5.0 | 36 | |
| Steering Stem Nut | 4.9 | 0.50 | 43 in·lb | |
| Frame | | | | |
| Downtube Bolts | 44 | 4.5 | 32 | |
| Footpeg Bracket Bolts (Front) | 34 | 3.5 | 25 | |
| Footpeg Bracket Bolts (Rear) | 25 | 2.5 | 18 | |
| Muffler Bracket Bolts (Lower) | 34 | 3.5 | 25 | |
| Muffler Bracket Bolts (Upper) | 34 | 3.5 | 25 | |
| Sidestand Mounting Bolt | 44 | 4.5 | 32 | |
| Sidestand Mounting Nut | 44 | 4.5 | 32 | R |
| Sidestand Switch Mounting Bolt | 8.8 | 0.90 | 78 in·lb | L |
| Rear View Mirror (Lower Hexagonal Area) | 30 | 3.1 | 22 | |
| Rear View Mirror (Upper Hexagonal Area) | 18 | 1.8 | 13 | Lh |
| Electrical System | | | | |
| Alternator Cover Bolts | 9.8 | 1.0 | 87 in·lb | |
| Alternator Lead Holder Plate Bolts | 5.9 | 0.60 | 52 in·lb | |
| Alternator Outer Cover Bolts | 9.8 | 1.0 | 87 in·lb | |
| Alternator Rotor Bolt: | | | | |
| First | 69 | 7.0 | 51 | MO, S |
| Final | 160 | 16.3 | 118 | MO, S |
| Crankshaft Sensor Bolts | 5.9 | 0.60 | 52 in·lb | |
| Fuel Level Sensor Mounting Bolts | 6.9 | 0.70 | 61 in·lb | L |
| Headlight Rim Screws | 2.9 | 0.30 | 26 in·lb | |

2-10 PERIODIC MAINTENANCE

Torque and Locking Agent

| Fastener | Torque | | | Remarks | |
|--|--------|-------|-----------|---------|---|
| | N·m | kgf·m | ft·lb | | |
| Ignition Coil Bracket Bolts | 9.8 | 1.0 | 87 in·lb | L | |
| Ignition Coil Mounting Nuts | 6.9 | 0.70 | 61 in·lb | | |
| Oxygen Sensors (Oxygen Sensor Equipped Models) | 25 | 2.5 | 18 | | |
| Regulator/Rectifier Bolts | 6.9 | 0.70 | 61 in·lb | | |
| Sidestand Switch Mounting Bolt | 8.8 | 0.90 | 78 in·lb | | |
| Spark Plugs | 18 | 1.8 | 13 | | |
| Speed Sensor Mounting Bolt | 9.8 | 1.0 | 87 in·lb | | |
| Starter Motor Cable Terminal Nut | 5.9 | 0.60 | 52 in·lb | | |
| Starter Motor Mounting Bolts | 9.8 | 1.0 | 87 in·lb | | |
| Starter Motor Terminal Locknut | 11 | 1.1 | 97 in·lb | | |
| Starter Motor Through Bolts | 4.9 | 0.50 | 43 in·lb | | |
| Starter Relay Terminal Screws | 3.9 | 0.40 | 35 in·lb | | |
| Stator Coil Bolts | 12 | 1.2 | 106 in·lb | | L |
| Tail/Brake Light Unit Mounting Nuts | 5.9 | 0.60 | 52 in·lb | | |
| Timing Inspection Plate Bolts | 9.8 | 1.0 | 87 in·lb | | |

The table below, relating tightening torque to thread diameter, lists the basic torque for the bolts and nuts. Use this table for only the bolts and nuts which do not require a specific torque value. All of the values are for use with dry solvent-cleaned threads.

Basic Torque for General Fasteners

| Threads Diameter (mm) | Torque | | |
|--------------------------|-----------|-------------|---------------|
| | N·m | kgf·m | ft·lb |
| 5 | 3.4 ~ 4.9 | 0.35 ~ 0.50 | 30 ~ 43 in·lb |
| 6 | 5.9 ~ 7.8 | 0.60 ~ 0.80 | 52 ~ 69 in·lb |
| 8 | 14 ~ 19 | 1.4 ~ 1.9 | 10.0 ~ 13.5 |
| 10 | 25 ~ 34 | 2.6 ~ 3.5 | 19.0 ~ 25 |
| 12 | 44 ~ 61 | 4.5 ~ 6.2 | 33 ~ 45 |
| 14 | 73 ~ 98 | 7.4 ~ 10.0 | 54 ~ 72 |
| 16 | 115 ~ 155 | 11.5 ~ 16.0 | 83 ~ 115 |
| 18 | 165 ~ 225 | 17.0 ~ 23.0 | 125 ~ 165 |
| 20 | 225 ~ 325 | 23.0 ~ 33.0 | 165 ~ 240 |

Specifications

| Item | Standard | Service Limit |
|----------------------------------|--|--|
| Fuel System (DFI) | | |
| Throttle Grip Free Play | 2 ~ 3 mm (0.08 ~ 0.12 in.) | --- |
| Idle Speed | 1 000 ±50 r/min (rpm) | --- |
| Air Cleaner Element | Viscous paper element | --- |
| Cooling System | | |
| Coolant: | | |
| Type (Recommended) | Permanent type of antifreeze | --- |
| Color | Green | --- |
| Mixed Ratio | Soft water 50%, Coolant 50% | --- |
| Freezing Point | -35°C (-31°F) | --- |
| Total Amount | 2.2 L (2.3 US qt) | --- |
| Engine Top End | | |
| Valve Clearance: | | |
| Exhaust | 0.20 ~ 0.25 mm (0.0079 ~ 0.0098 in.) | --- |
| Inlet | 0.10 ~ 0.15 mm (0.0039 ~ 0.0059 in.) | --- |
| Clutch | | |
| Clutch Lever Free Play | 2 ~ 3 mm (0.08 ~ 0.12 in.) | --- |
| Engine Lubrication System | | |
| Engine Oil: | | |
| Type | API SG, SH, SJ, SL or SM with JASO MA, MA1 or MA2 | --- |
| Viscosity | SAE 10W-40 | --- |
| Capacity | 3.0 L (3.2 US qt) (when filter is not removed) | --- |
| | 3.2 L (3.4 US qt) (when filter is removed) | --- |
| | 3.7 L (3.9 US qt) (when engine is completely dry) | --- |
| Level | Between upper and lower level lines (after idling or running) | --- |
| Wheels/Tires | | |
| Tread Depth: | | |
| Front | 4.5 mm (0.18 in.) | 1 mm (0.04 in.), (AT, CH, DE) 1.6 mm (0.06 in.) |
| Rear | 7.4 mm (0.29 in.) | Up to 130 km/h (80 mph): 2 mm (0.08 in.), Over 130 km/h (80 mph): 3 mm (0.12 in.) |
| Air Pressure (when Cold): | | |
| Front | Up to 180 kg (397 lb) load: 280 kPa (2.80 kgf/cm ² , 40 psi) | --- |
| Rear | Up to 97.5 kg (215 lb) load: 200 kPa (2.00 kgf/cm ² , 28 psi) 97.5 ~ 180 kg (215 ~ 397 lb) load: 225 kPa (2.25 kgf/cm ² , 32 psi) | --- |

2-12 PERIODIC MAINTENANCE

Specifications

| Item | Standard | Service Limit |
|---|---|-----------------|
| Final Drive | | |
| Drive Belt Deflection: | | |
| (45 N, 4.6 kgf, 10 lb force) | 1.5 ~ 4.0 mm (0.06 ~ 0.16 in.) | - - - |
| When Installing New Belt or Engine is Remounted | 1.5 mm (0.06 in.) | - - - |
| Brakes | | |
| Brake Fluid: | | |
| Grade | DOT4 | - - - |
| Brake Pad Lining | | |
| Thickness: | | |
| Front | 4.5 mm (0.18 in.) | 1 mm (0.04 in.) |
| Rear | 7.0 mm (0.28 in.) | 1 mm (0.04 in.) |
| Brake Light Timing: | | |
| Front | Pulled ON | - - - |
| Rear | ON after about 10 mm (0.39 in.) of pedal travel | - - - |

Special Tools

Inside Circlip Pliers:
57001-143

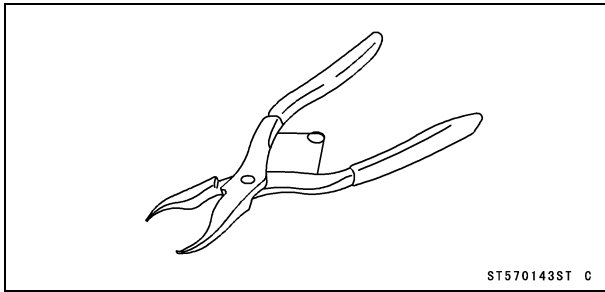

Spark Plug Wrench, Hex 16:
57001-1262

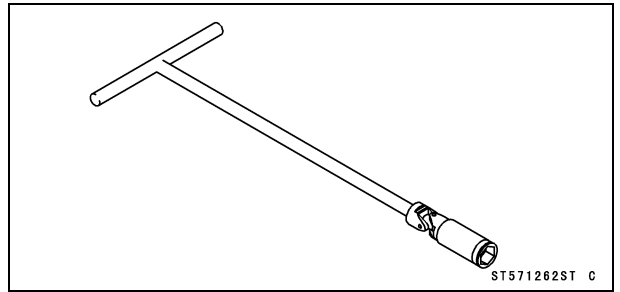

Steering Stem Nut Wrench:
57001-1100

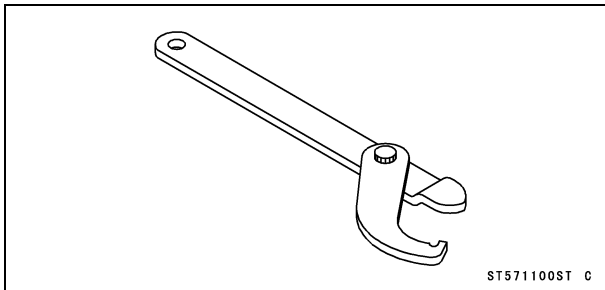

Filler Cap Driver:
57001-1454

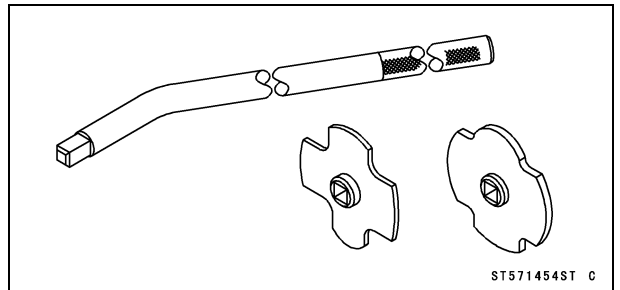

Jack:
57001-1238

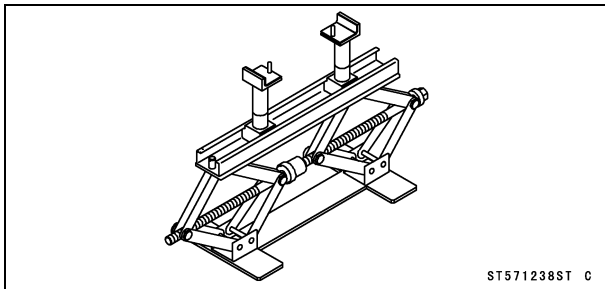

Tension Gauge:
57001-1585

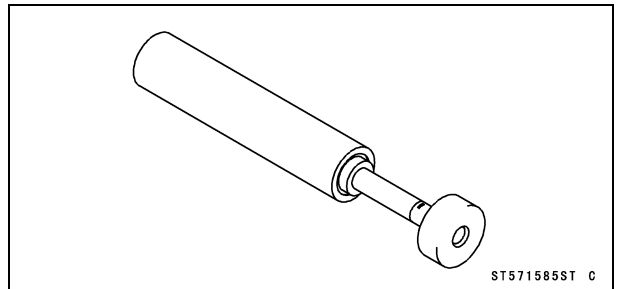

Oil Filter Wrench:
57001-1249

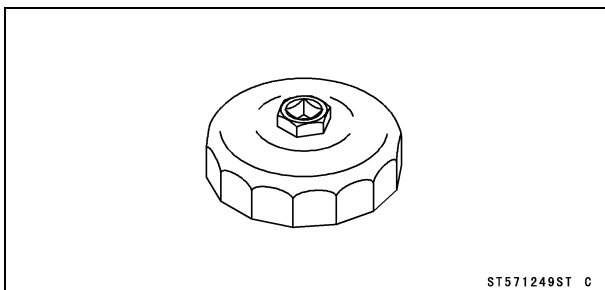

2-14 PERIODIC MAINTENANCE

Periodic Maintenance Procedures

Fuel System (DFI)

Throttle Control System Inspection

- Check the throttle grip free play [A].
- ★ If the free play is incorrect, adjust the throttle cable.

Throttle Grip Free Play

Standard: 2 ~ 3 mm (0.08 ~ 0.12 in.)

- Check that the throttle grip moves smoothly from full open to close, and the throttle closes quickly and completely by the return spring in all steering positions.
- ★ If the throttle grip doesn't return properly, check the throttle cable routing, grip free play, and cable damage. Then lubricate the throttle cable.
- If necessary, adjust the throttle cable as follows.
- Loosen the locknuts [A] and screw the adjusters [B] all the way in so as to give the throttle grip plenty of play.
- Turn out the adjuster of the decelerator cable [C] until there is no play.
- Tighten the locknut against the adjuster.
- Turn the adjuster of the accelerator cable [D] until the proper amount of throttle grip free play is obtained and tighten the locknut against the adjuster.

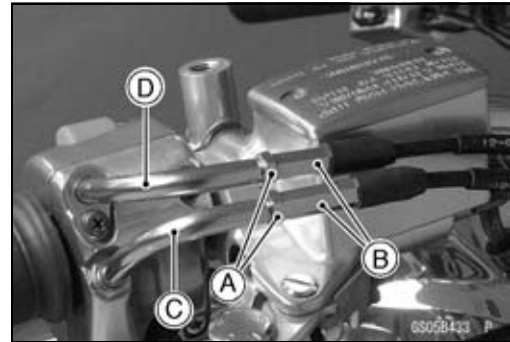
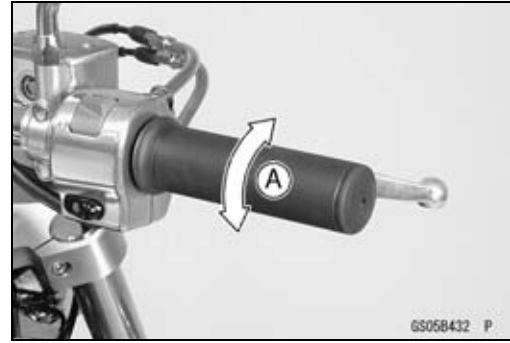

Idle Speed Inspection

- Start the engine and warm it up thoroughly.
- At first the engine will run fast to decrease warm up time (fast idle).
- Gradually the fast idle will lower to a certain RPM automatically. This is the idle speed.
- With the engine idling, turn the handlebar to both sides.
- ★ If handlebar movement changes the idle speed, the throttle cables may be improperly adjusted or incorrectly routed or damaged. Be sure to correct any of these conditions before riding (see Throttle Control System Inspection or Cable, Wire, and Hose Routing section in the Appendix chapter).

⚠ WARNING

Operation with an improperly adjusted, incorrectly routed or damaged cables could result in an unsafe riding Condition. Follow the service manual to be make sure to correct any of these conditions.

- Check the idle speed.
- ★ If the idle speed is out of the specified range, adjust it.

Idle Speed

Standard: 1 000 ±50 r/min (rpm)

Periodic Maintenance Procedures

Idle Speed Adjustment

- Start the engine and warm it up thoroughly.
- Wait until fast idle speed lowers to a certain value.
- Turn the adjusting screw [A] until the idle speed is correct.
- Open and close the throttle a few times to make sure that the idle speed is within the specified range. Readjust if necessary.



Fuel Hose Inspection (fuel leak, damage, installation condition)

- The fuel hose is designed to be used throughout the motorcycle's life without any maintenance. However, if the motorcycle is not properly handled, the high pressure inside the fuel line can cause fuel to leak [A] or the hose to burst. Remove the fuel tank (see Fuel Tank Removal in the Fuel System (DFI) chapter) and check the fuel hose.
- ★ Replace the fuel hose if any fraying, cracks [B] or bulges [C] are noticed.
- Check that the hoses are routed according to Cable, Wire, and Hose Routing section in the Appendix chapter.
- ★ Replace the hose if it has been sharply bent or kinked.
- Hose Joints [A]
- Fuel Hose [B]

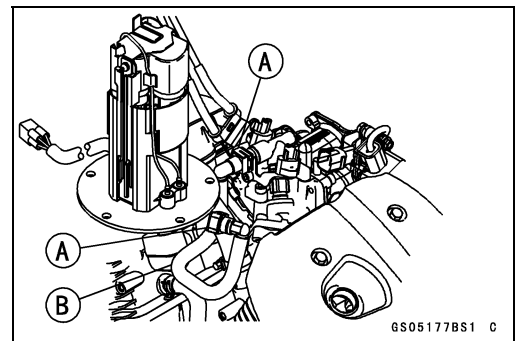
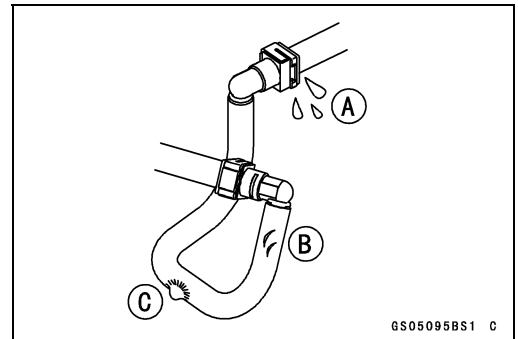

- Check that the hose joints are securely connected.
- Push and pull [A] the hose joint [B] back and forth more than two times, and make sure it is locked.
- ★ If it does not locked, reinstall the hose joint.

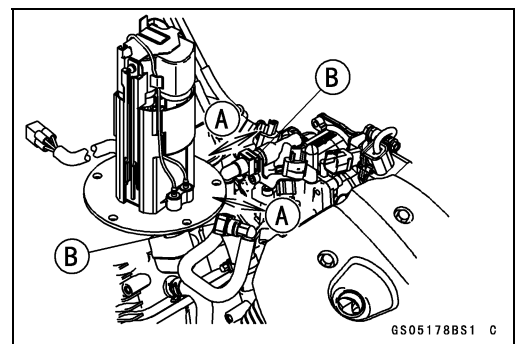

⚠ WARNING

Leaking fuel can cause a fire or explosion resulting in serious burns. Make sure the hose joint is installed correctly on the delivery pipe by sliding the joint.

2-16 PERIODIC MAINTENANCE

Periodic Maintenance Procedures

Evaporative Emission Control System Inspection (CAL, TH, SEA-B1)

Evaporative Emission Control System Inspection

- Inspect the canister as follows.
- Remove:
 - Mufflers (see Muffler Removal in the Engine Top End chapter)
 - Bolts [A]
- Remove the band [B] and take out the canister [C].

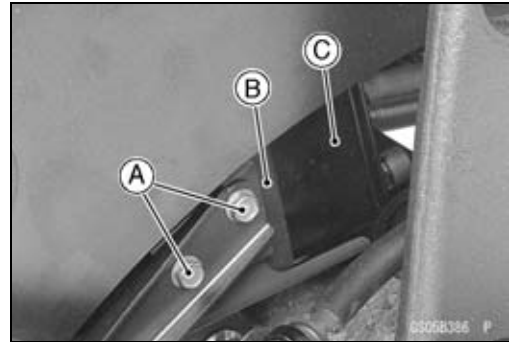

- Disconnect the hoses [A] from the canister.
- Visually inspect the canister for cracks and other damage.
- ★ If the canister has any cracks or bad damage, replace it with a new one.

NOTE

○ *The canister is designed to work well through the motorcycle's life without any maintenance if it is used under normal conditions.*

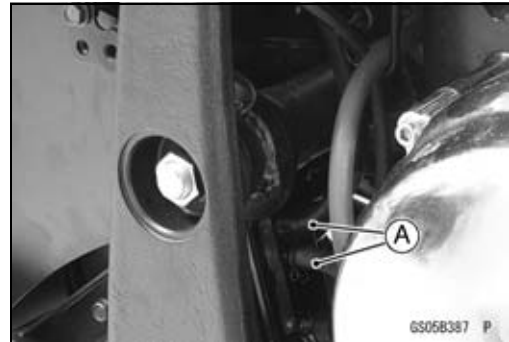

- Install the canister and hoses.
- Route the hoses according to Cable, Wire, and Hose Routing section in the Appendix chapter. Refer to the diagram of the evaporative emission control system in the Fuel System (DFI) chapter too.

- Check the liquid/vapor separator as follows.
- Remove the band [A].
- Take out the separator [B].
- Disconnect the hoses [C] from the separator.
- Visually inspect the separator for cracks and other damage.
- ★ If the separator has any cracks or damage, replace it with a new one.
- To prevent the gasoline from flowing into or out of the canister, hold the separator perpendicular to the ground.
- Check the hoses of the evaporative emission control system as follows.
- Check that the hoses are securely connected and clips are in position.
- Replace any kinked, deteriorated or damaged hoses.
- Route the hoses according to Cable, Wire, and Hose Routing section in the Appendix chapter. Refer to the diagram of the evaporative emission control system in the Fuel System (DFI) chapter too.
- When installing the hoses, avoid sharp bending, kinking, flattening or twisting, and route the hoses with a minimum of bending so that the emission flow will not be obstructed.

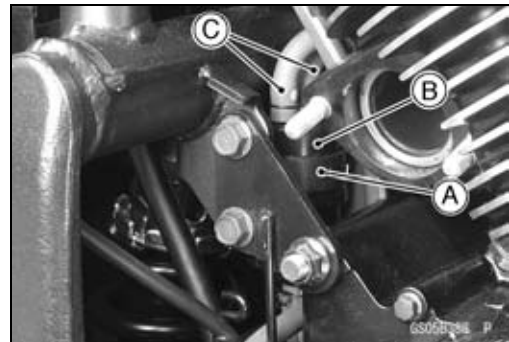

Periodic Maintenance Procedures

Cooling System

Coolant Level Inspection

NOTE

○ Check the level when the engine is cold (room or ambient temperature).

- Check the coolant level in the reserve tank [A] with the motorcycle held perpendicular (Do not use the sidestand).
- ★ If the coolant level is lower than the "L" level line [B], remove the reserve tank cover (see Reserve Tank Removal in the Cooling System chapter) and unscrew the reserve tank cap, and add coolant to the "F" level line [C].

"L": low

"F": full

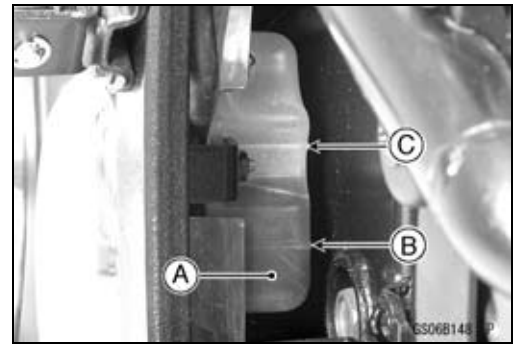

NOTICE

For refilling, add the specified mixture of coolant and soft water. Adding water alone dilutes the coolant and degrades its anticorrosion properties. The diluted coolant can attack the aluminum engine parts. In an emergency, soft water alone can be added. But the diluted coolant must be returned to the correct mixture ratio within a few days. If coolant must be added often or the reservoir tank has run completely dry, there is probably leakage in the cooling system. Check the system for leaks. Coolant ruins painted surfaces. Immediately wash away any coolant that spills on the frame, engine, wheels or other painted parts.

Radiator Hose Damage and Installation Condition Inspection

- The high pressure inside the radiator hose and pipe can cause coolant to leak [A] or the hose to burst if the line is not properly maintained.
- Visually inspect the hoses for signs of deterioration. Squeeze the hoses. A hose should not be hard and brittle, nor should it be soft or swollen.
- ★ Replace the hose if any fraying, cracks [B] or bulges [C] are noticed.
- Check that the hoses are securely connected and clamps are tightened correctly.

Torque - Radiator Hose Clamp Screws: 2.0 N·m (0.20 kgf·m, 18 in·lb)

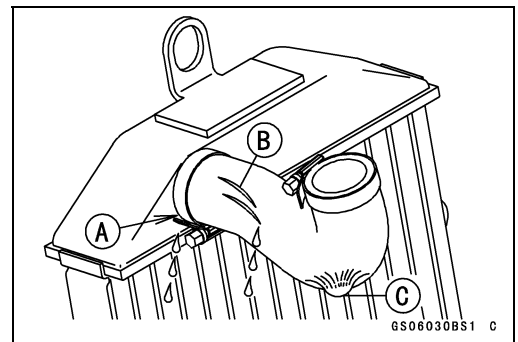

2-18 PERIODIC MAINTENANCE

Periodic Maintenance Procedures

Engine Top End

Air Suction System Damage Inspection

- Disconnect the air switching valve hose [A] out of the right air cleaner housing.
- Start the engine and run it at idle speed.
- Plug the air switching valve hose end with your finger and feel vacuum pulsing in the hose.
- ★ If there is no vacuum pulsation, check the hose line for leak.
- ★ If there is no leak, check the air switching valve (see Air Switching Valve Unit Test in the Electrical System chapter) or air suction valve (see Air Suction Valve Inspection in the Engine Top End chapter).



Valve Clearance Inspection

NOTE

○ Valve clearance must be checked and adjusted when the engine is cold (room temperature).

- Remove:
 - Cylinder Head Cover (see Cylinder Head Cover Removal in the Engine Top End chapter)
 - Timing Inspection Plate (Engine Left Side)
- Set the front piston at TDC (see Camshaft Installation in the Engine Top End chapter).
- Using a thickness gauge [A], measure the valve clearance between the rocker arm [B] and the shim [C].

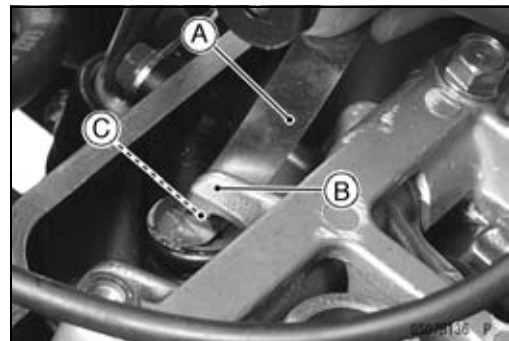

- Set the rear piston at TDC by turning the crankshaft counterclockwise 305° (see Camshaft Installation in the Engine Top End chapter).
- Using a thickness gauge, measure the valve clearance between the rocker arm and the shim.

Valve Clearance

Standard:

Exhaust 0.20 ~ 0.25 mm (0.0079 ~ 0.0098 in.)

Inlet 0.10 ~ 0.15 mm (0.0039 ~ 0.0059 in.)

- ★ If the valve clearance is not within the specified range, first record the clearance, and then adjust it.

Periodic Maintenance Procedures

Valve Clearance Adjustment

- To change the valve clearance, slide [A] the rocker arm [B] sideways and change the shim [C]. Replace the shim with one of a different thickness.

NOTE

- Mark and record the shim locations so that the shims can be reinstalled in their original positions.
- If there is no clearance, select a shim which is several sizes smaller and then measure the clearance.

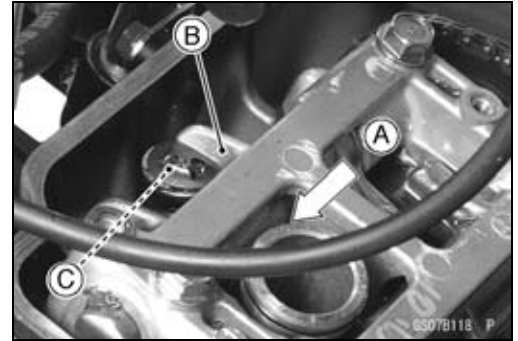

- To select a new shim which brings the valve clearance within the specified range, refer to the Valve Clearance Adjustment Charts.
- Remeasure any valve clearance that was adjusted. Readjust if necessary.

NOTICE

Do not put shim stock under the shim. This may cause the shim to pop out at high rpm, causing extensive engine damage.

Do not grind the shim. This may cause it to fracture, causing extensive engine damage.

2-20 PERIODIC MAINTENANCE

Periodic Maintenance Procedures

VALVE CLEARANCE ADJUSTMENT CHART INLET VALVE

| | PRESENT SHIM | | | | | | | | | | | | | | | | | | | Example | | |
|-------------------|--------------|------|------|------|------|------|------|------|------|------|------|------|------|------|------|------|------|------|------|---------|------|--|
| PART No. (92025-) | 1870 | 1871 | 1872 | 1873 | 1874 | 1875 | 1876 | 1877 | 1878 | 1879 | 1880 | 1881 | 1882 | 1883 | 1884 | 1885 | 1886 | 1887 | 1888 | 1889 | 1890 | |
| MARK | 0 | 5 | 10 | 15 | 20 | 25 | 30 | 35 | 40 | 45 | 50 | 55 | 60 | 65 | 70 | 75 | 80 | 85 | 90 | 95 | 00 | |
| THICKNESS (mm) | 2.00 | 2.05 | 2.10 | 2.15 | 2.20 | 2.25 | 2.30 | 2.35 | 2.40 | 2.45 | 2.50 | 2.55 | 2.60 | 2.65 | 2.70 | 2.75 | 2.80 | 2.85 | 2.90 | 2.95 | 3.00 | |

| VALVE CLEARANCE MEASUREMENT | Example | PRESENT SHIM | | | | | | | | | | | | | | | | | | | | |
|-----------------------------|---------|--|------|------|------|------|------|------|------|------|------|------|------|------|------|------|------|------|------|------|------|------|
| | | 1.90 | 1.95 | 2.00 | 2.05 | 2.10 | 2.15 | 2.20 | 2.25 | 2.30 | 2.35 | 2.40 | 2.45 | 2.50 | 2.55 | 2.60 | 2.65 | 2.70 | 2.75 | 2.80 | 2.85 | 2.90 |
| 0.00~0.04 | Example | 1.90 | 1.95 | 2.00 | 2.05 | 2.10 | 2.15 | 2.20 | 2.25 | 2.30 | 2.35 | 2.40 | 2.45 | 2.50 | 2.55 | 2.60 | 2.65 | 2.70 | 2.75 | 2.80 | 2.85 | 2.90 |
| 0.05~0.09 | | 1.95 | 2.00 | 2.05 | 2.10 | 2.15 | 2.20 | 2.25 | 2.30 | 2.35 | 2.40 | 2.45 | 2.50 | 2.55 | 2.60 | 2.65 | 2.70 | 2.75 | 2.80 | 2.85 | 2.90 | 2.95 |
| 0.10~0.15 | | SPECIFIED CLEARANCE/NO CHANGE REQUIRED | | | | | | | | | | | | | | | | | | | | |
| 0.16~0.20 | | 2.05 | 2.10 | 2.15 | 2.20 | 2.25 | 2.30 | 2.35 | 2.40 | 2.45 | 2.50 | 2.55 | 2.60 | 2.65 | 2.70 | 2.75 | 2.80 | 2.85 | 2.90 | 2.95 | 3.00 | |
| 0.21~0.25 | | 2.10 | 2.15 | 2.20 | 2.25 | 2.30 | 2.35 | 2.40 | 2.45 | 2.50 | 2.55 | 2.60 | 2.65 | 2.70 | 2.75 | 2.80 | 2.85 | 2.90 | 2.95 | 3.00 | | |
| 0.26~0.30 | | 2.15 | 2.20 | 2.25 | 2.30 | 2.35 | 2.40 | 2.45 | 2.50 | 2.55 | 2.60 | 2.65 | 2.70 | 2.75 | 2.80 | 2.85 | 2.90 | 2.95 | 3.00 | | | |
| 0.31~0.35 | | 2.20 | 2.25 | 2.30 | 2.35 | 2.40 | 2.45 | 2.50 | 2.55 | 2.60 | 2.65 | 2.70 | 2.75 | 2.80 | 2.85 | 2.90 | 2.95 | 3.00 | | | | |
| 0.36~0.40 | | 2.25 | 2.30 | 2.35 | 2.40 | 2.45 | 2.50 | 2.55 | 2.60 | 2.65 | 2.70 | 2.75 | 2.80 | 2.85 | 2.90 | 2.95 | 3.00 | | | | | |
| 0.41~0.45 | | 2.30 | 2.35 | 2.40 | 2.45 | 2.50 | 2.55 | 2.60 | 2.65 | 2.70 | 2.75 | 2.80 | 2.85 | 2.90 | 2.95 | 3.00 | | | | | | |
| 0.46~0.50 | | 2.35 | 2.40 | 2.45 | 2.50 | 2.55 | 2.60 | 2.65 | 2.70 | 2.75 | 2.80 | 2.85 | 2.90 | 2.95 | 3.00 | | | | | | | |
| 0.51~0.55 | | 2.40 | 2.45 | 2.50 | 2.55 | 2.60 | 2.65 | 2.70 | 2.75 | 2.80 | 2.85 | 2.90 | 2.95 | 3.00 | | | | | | | | |
| 0.56~0.60 | | 2.45 | 2.50 | 2.55 | 2.60 | 2.65 | 2.70 | 2.75 | 2.80 | 2.85 | 2.90 | 2.95 | 3.00 | | | | | | | | | |
| 0.61~0.65 | | 2.50 | 2.55 | 2.60 | 2.65 | 2.70 | 2.75 | 2.80 | 2.85 | 2.90 | 2.95 | 3.00 | | | | | | | | | | |
| 0.66~0.70 | | 2.55 | 2.60 | 2.65 | 2.70 | 2.75 | 2.80 | 2.85 | 2.90 | 2.95 | 3.00 | | | | | | | | | | | |
| 0.71~0.75 | | 2.60 | 2.65 | 2.70 | 2.75 | 2.80 | 2.85 | 2.90 | 2.95 | 3.00 | | | | | | | | | | | | |
| 0.76~0.80 | | 2.65 | 2.70 | 2.75 | 2.80 | 2.85 | 2.90 | 2.95 | 3.00 | | | | | | | | | | | | | |
| 0.81~0.85 | | 2.70 | 2.75 | 2.80 | 2.85 | 2.90 | 2.95 | 3.00 | | | | | | | | | | | | | | |
| 0.86~0.90 | | 2.75 | 2.80 | 2.85 | 2.90 | 2.95 | 3.00 | | | | | | | | | | | | | | | |
| 0.91~0.95 | | 2.80 | 2.85 | 2.90 | 2.95 | 3.00 | | | | | | | | | | | | | | | | |
| 0.96~1.00 | | 2.85 | 2.90 | 2.95 | 3.00 | | | | | | | | | | | | | | | | | |
| 1.01~1.05 | | 2.90 | 2.95 | 3.00 | | | | | | | | | | | | | | | | | | |
| 1.06~1.10 | | 2.95 | 3.00 | | | | | | | | | | | | | | | | | | | |
| 1.11~1.15 | | 3.00 | | | | | | | | | | | | | | | | | | | | |

| Parts No. | Thickness |
|------------|-----------|
| 92180-1208 | 1.95 mm |
| 92180-1209 | 1.90 mm |
| 92180-1210 | 1.85 mm |
| 92180-1211 | 1.80 mm |
| 92180-1212 | 1.75 mm |
| 92180-1213 | 1.70 mm |

The shim from 1.70 to 1.95 mm thick are also available.

INSTALL THE SHIM OF THIS THICKNESS (mm)

GS07091BW3 C

1. Measure the clearance (when engine is cold).
2. Check present shim size.
3. Match clearance in vertical column with present shim size in horizontal column.
4. Install the shim specified where the lines intersect. This shim will give the proper clearance.

Example: Present shim is **2.60 mm** (0.102 in.).
 Measured clearance is **0.25 mm** (0.010 in.).
 Replace **2.60 mm** (0.102 in.) shim with **2.70 mm** (0.106 in.) shim.

5. Remeasure the valve clearance and readjust if necessary.

Periodic Maintenance Procedures

VALVE CLEARANCE ADJUSTMENT CHART EXHAUST VALVE

| | PRESENT SHIM | | | | | | | | | | | | | | | | | | | | |
|-------------------|--------------|------|------|------|------|------|------|------|------|------|------|------|------|------|------|------|------|------|------|------|------|
| | Example | | | | | | | | | | | | | | | | | | | | |
| PART No. (92025-) | 1870 | 1871 | 1872 | 1873 | 1874 | 1875 | 1876 | 1877 | 1878 | 1879 | 1880 | 1881 | 1882 | 1883 | 1884 | 1885 | 1886 | 1887 | 1888 | 1889 | 1890 |
| MARK | 0 | 5 | 10 | 15 | 20 | 25 | 30 | 35 | 40 | 45 | 50 | 55 | 60 | 65 | 70 | 75 | 80 | 85 | 90 | 95 | 00 |
| THICKNESS (mm) | 2.00 | 2.05 | 2.10 | 2.15 | 2.20 | 2.25 | 2.30 | 2.35 | 2.40 | 2.45 | 2.50 | 2.55 | 2.60 | 2.65 | 2.70 | 2.75 | 2.80 | 2.85 | 2.90 | 2.95 | 3.00 |

| VALVE CLEARANCE MEASUREMENT | SPECIFIED CLEARANCE/NO CHANGE REQUIRED | | | | | | | | | | | | | | | | | | | | | |
|-----------------------------|--|------|------|------|------|------|------|------|------|------|------|------|------|------|------|------|------|------|------|------|------|------|
| | Example | 1.75 | 1.80 | 1.85 | 1.90 | 1.95 | 2.00 | 2.05 | 2.10 | 2.15 | 2.20 | 2.25 | 2.30 | 2.35 | 2.40 | 2.45 | 2.50 | 2.55 | 2.60 | 2.65 | 2.70 | 2.75 |
| 0.00~0.04 | 1.80 | 1.85 | 1.90 | 1.95 | 2.00 | 2.05 | 2.10 | 2.15 | 2.20 | 2.25 | 2.30 | 2.35 | 2.40 | 2.45 | 2.50 | 2.55 | 2.60 | 2.65 | 2.70 | 2.75 | 2.80 | |
| 0.05~0.09 | 1.85 | 1.90 | 1.95 | 2.00 | 2.05 | 2.10 | 2.15 | 2.20 | 2.25 | 2.30 | 2.35 | 2.40 | 2.45 | 2.50 | 2.55 | 2.60 | 2.65 | 2.70 | 2.75 | 2.80 | 2.85 | |
| 0.10~0.14 | 1.90 | 1.95 | 2.00 | 2.05 | 2.10 | 2.15 | 2.20 | 2.25 | 2.30 | 2.35 | 2.40 | 2.45 | 2.50 | 2.55 | 2.60 | 2.65 | 2.70 | 2.75 | 2.80 | 2.85 | 2.90 | |
| 0.15~0.19 | 1.95 | 2.00 | 2.05 | 2.10 | 2.15 | 2.20 | 2.25 | 2.30 | 2.35 | 2.40 | 2.45 | 2.50 | 2.55 | 2.60 | 2.65 | 2.70 | 2.75 | 2.80 | 2.85 | 2.90 | 2.95 | |
| 0.20~0.25 | 2.00 | 2.05 | 2.10 | 2.15 | 2.20 | 2.25 | 2.30 | 2.35 | 2.40 | 2.45 | 2.50 | 2.55 | 2.60 | 2.65 | 2.70 | 2.75 | 2.80 | 2.85 | 2.90 | 2.95 | 3.00 | |
| 0.26~0.30 | 2.05 | 2.10 | 2.15 | 2.20 | 2.25 | 2.30 | 2.35 | 2.40 | 2.45 | 2.50 | 2.55 | 2.60 | 2.65 | 2.70 | 2.75 | 2.80 | 2.85 | 2.90 | 2.95 | 3.00 | | |
| 0.31~0.35 | 2.10 | 2.15 | 2.20 | 2.25 | 2.30 | 2.35 | 2.40 | 2.45 | 2.50 | 2.55 | 2.60 | 2.65 | 2.70 | 2.75 | 2.80 | 2.85 | 2.90 | 2.95 | 3.00 | | | |
| 0.36~0.40 | 2.15 | 2.20 | 2.25 | 2.30 | 2.35 | 2.40 | 2.45 | 2.50 | 2.55 | 2.60 | 2.65 | 2.70 | 2.75 | 2.80 | 2.85 | 2.90 | 2.95 | 3.00 | | | | |
| 0.41~0.45 | 2.20 | 2.25 | 2.30 | 2.35 | 2.40 | 2.45 | 2.50 | 2.55 | 2.60 | 2.65 | 2.70 | 2.75 | 2.80 | 2.85 | 2.90 | 2.95 | 3.00 | | | | | |
| 0.46~0.50 | 2.25 | 2.30 | 2.35 | 2.40 | 2.45 | 2.50 | 2.55 | 2.60 | 2.65 | 2.70 | 2.75 | 2.80 | 2.85 | 2.90 | 2.95 | 3.00 | | | | | | |
| 0.51~0.55 | 2.30 | 2.35 | 2.40 | 2.45 | 2.50 | 2.55 | 2.60 | 2.65 | 2.70 | 2.75 | 2.80 | 2.85 | 2.90 | 2.95 | 3.00 | | | | | | | |
| 0.56~0.60 | 2.35 | 2.40 | 2.45 | 2.50 | 2.55 | 2.60 | 2.65 | 2.70 | 2.75 | 2.80 | 2.85 | 2.90 | 2.95 | 3.00 | | | | | | | | |
| 0.61~0.65 | 2.40 | 2.45 | 2.50 | 2.55 | 2.60 | 2.65 | 2.70 | 2.75 | 2.80 | 2.85 | 2.90 | 2.95 | 3.00 | | | | | | | | | |
| 0.66~0.70 | 2.45 | 2.50 | 2.55 | 2.60 | 2.65 | 2.70 | 2.75 | 2.80 | 2.85 | 2.90 | 2.95 | 3.00 | | | | | | | | | | |
| 0.71~0.75 | 2.50 | 2.55 | 2.60 | 2.65 | 2.70 | 2.75 | 2.80 | 2.85 | 2.90 | 2.95 | 3.00 | | | | | | | | | | | |
| 0.76~0.80 | 2.55 | 2.60 | 2.65 | 2.70 | 2.75 | 2.80 | 2.85 | 2.90 | 2.95 | 3.00 | | | | | | | | | | | | |
| 0.81~0.85 | 2.60 | 2.65 | 2.70 | 2.75 | 2.80 | 2.85 | 2.90 | 2.95 | 3.00 | | | | | | | | | | | | | |
| 0.86~0.90 | 2.65 | 2.70 | 2.75 | 2.80 | 2.85 | 2.90 | 2.95 | 3.00 | | | | | | | | | | | | | | |
| 0.91~0.95 | 2.70 | 2.75 | 2.80 | 2.85 | 2.90 | 2.95 | 3.00 | | | | | | | | | | | | | | | |
| 0.96~1.00 | 2.75 | 2.80 | 2.85 | 2.90 | 2.95 | 3.00 | | | | | | | | | | | | | | | | |
| 1.01~1.05 | 2.80 | 2.85 | 2.90 | 2.95 | 3.00 | | | | | | | | | | | | | | | | | |
| 1.06~1.10 | 2.85 | 2.90 | 2.95 | 3.00 | | | | | | | | | | | | | | | | | | |
| 1.11~1.15 | 2.90 | 2.95 | 3.00 | | | | | | | | | | | | | | | | | | | |
| 1.16~1.20 | 2.95 | 3.00 | | | | | | | | | | | | | | | | | | | | |
| 1.21~1.25 | 3.00 | | | | | | | | | | | | | | | | | | | | | |
| 1.26~1.30 | | | | | | | | | | | | | | | | | | | | | | |

| Parts No. | Thickness |
|------------|-----------|
| 92180-1208 | 1.95 mm |
| 92180-1209 | 1.90 mm |
| 92180-1210 | 1.85 mm |
| 92180-1211 | 1.80 mm |
| 92180-1212 | 1.75 mm |
| 92180-1213 | 1.70 mm |

The shim from 1.70 to 1.95 mm thick are also available.

INSTALL THE SHIM OF THIS THICKNESS (mm)

GS07092BW3 C

1. Measure the clearance (when engine is cold).
 2. Check present shim size.
 3. Match clearance in vertical column with present shim size in horizontal column.
 4. Install the shim specified where the lines intersect. This shim will give the proper clearance.
- Example:** Present shim is **2.55 mm** (0.100 in.).
 Measured clearance is **0.50 mm** (0.020 in.).
 Replace **2.55 mm** (0.100 in.) shim with **2.75 mm** (0.108 in.) shim.
5. Remeasure the valve clearance and readjust if necessary.

2-22 PERIODIC MAINTENANCE

Periodic Maintenance Procedures

Clutch

Clutch Operation Inspection

- Pull the clutch lever just enough to take up the free play [A].
- Measure the gap between the lever and the lever holder.
- ★ If the gap is too wide, the clutch may not release fully. If the gap is too narrow, the clutch may not engage fully. In either case, adjust it.

Clutch Lever Free Play

Standard: 2 ~ 3 mm (0.08 ~ 0.12 in.)

⚠ WARNING

The engine and exhaust system get extremely hot during normal operation and can cause serious burns. Never touch the engine or exhaust pipe during clutch adjustment.

- Loosen the locknut [A] at the clutch lever.
- Turn the adjuster [B] until the proper amount of clutch lever free play is obtained.
- Tighten the locknut securely.
- ★ If it cannot be done, use the adjuster at the middle of the cable.

- Loosen the locknut [A] at the middle of the clutch cable.
- Turn the adjuster nut [B] until the proper amount of clutch lever free play is obtained.
- Tighten the locknut securely.
- ★ If it cannot be done, use the mounting nuts at the lower end of the cable.

- Slide the rubber dust cover [A] at the clutch cable lower end out of place.
- Loosen both adjusting nuts [B] at the clutch cover as far as they will go.
- Pull the clutch outer cable [C] tight and tighten the adjusting nuts against the bracket [D].
- Slip the rubber dust cover back onto place.
- Turn the adjuster at the clutch lever until the free play is correct.
- Tighten the locknut at the clutch lever.

⚠ WARNING

Too much cable play can prevent clutch disengagement and cause an accident resulting in serious injury or death. When adjusting the clutch or replacing the cable, be sure the upper end of the clutch outer cable is fully seated in its fitting, or it could slip into place later, creating enough cable play to prevent clutch disengagement.

- After the adjustment, start the engine and check that the clutch does not slip and that it releases properly.

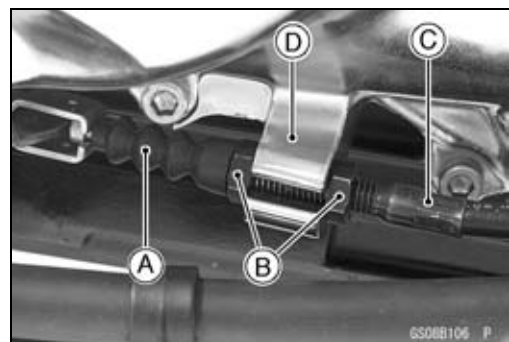
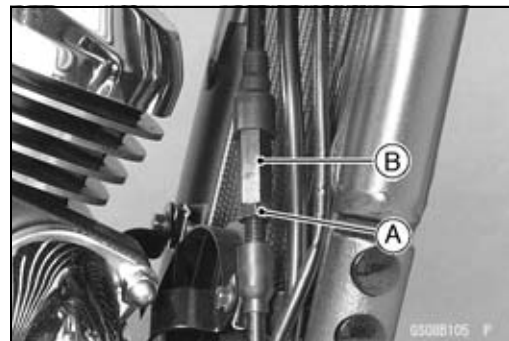
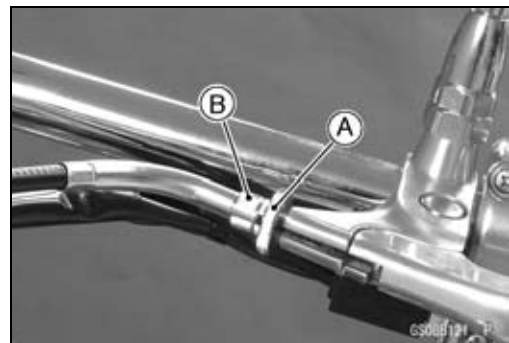

Periodic Maintenance Procedures

Wheels/Tires

Air Pressure Inspection

- Remove the air valve cap.
- Measure the tire air pressure with an air pressure gauge [A] when the tires are cold (that is, when the motorcycle has not been ridden more than a mile during the past 3 hours).
- Install the air valve cap.
- ★ Adjust the tire air pressure according to the specifications if necessary.

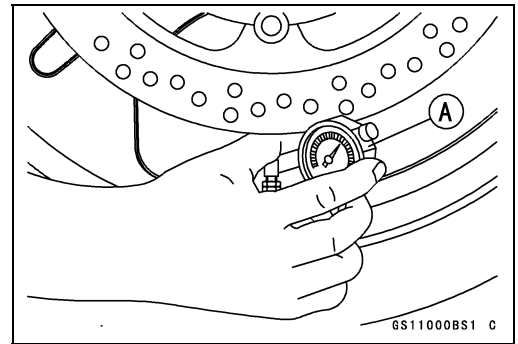

Air Pressure (when Cold)

- Front:** Up to 180 kg (397 lb)
280 kPa (2.80 kgf/cm², 40 psi)
- Rear:** Up to 97.5 kg (215 lb)
200 kPa (2.00 kgf/cm², 28 psi)
97.5 ~ 180 kg (215 ~ 397 lb)
225 kPa (2.25 kgf/cm², 32 psi)

Wheel/Tire Damage Inspection

- Remove any imbedded stones [A] or other foreign particles [B] from tread.
- Visually inspect the tire for cracks and cuts, and replace the tire if necessary. Swelling or high spots indicate internal damage, requiring tire replacement.
- Visually inspect the wheel for cracks, cuts and dents damage.
- ★ If any damage is found, replace the wheel if necessary.



Tire Tread Wear Inspection

As the tire tread wears down, the tire becomes more susceptible to puncture and failure. An accepted estimate is that 90% of all tire failures occur during the last 10% of tread life (90% worn). So it is false economy and unsafe to use the tires until they are bald.

2-24 PERIODIC MAINTENANCE

Periodic Maintenance Procedures

- Measure the tread depth at the center of the tread with a depth gauge [A]. Since the tire may wear unevenly, take measurement at several places.
- ★ If any measurement is less than the service limit, replace the tire (see Tire Removal/Installation in the Wheels/Tires chapter).

Tread Depth

Standard:

| | |
|-------|-------------------|
| Front | 4.5 mm (0.18 in.) |
| Rear | 7.4 mm (0.29 in.) |

Service Limit:

| | |
|-------|---|
| Front | 1 mm (0.04 in.) (AT, CH, DE) 1.6 mm (0.06 in.) |
| Rear | 2 mm (0.08 in.) (Up to 130 km/h (80 mph)) 3 mm (0.12 in.) (Over 130 km/h (80 mph)) |

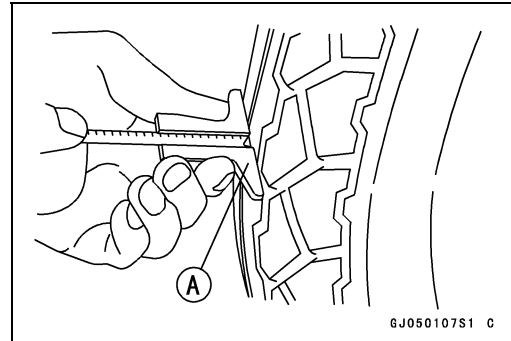

WARNING

Some replacement tires may adversely affect handling and cause an accident resulting in serious injury or death. To ensure proper handling and stability, use only the recommended standard tires for replacement, inflated to the standard pressure.

NOTE

- Most countries may have their own regulations a minimum tire tread depth; be sure to follow them.
- Check and balance the wheel when a tire is replaced with a new one.

Wheel Bearing Damage Inspection

- Raise the front wheel off the ground with jack (see Front Wheel Removal in the Wheels/Tires chapter).
- Turn the handlebar all the way to the right or left.
- Inspect the roughness of the front wheel bearing by moving [A] the wheel to be both side.
- Spin the front wheel lightly, and check for smoothly turn, roughness, binding or noise.
- ★ If roughness, binding or noise is found, remove the front wheel (see Front Wheel Removal in the Wheels/Tires chapter) and inspect the wheel bearing (see Hub Bearing Inspection in the Wheels/Tires chapter).



Periodic Maintenance Procedures

- Raise the rear wheel off the ground with jack (see Rear Wheel Removal in the Wheels/Tires chapter).
- Inspect the roughness of the rear wheel bearing by moving the wheel to be both side.
- Spin [A] the rear wheel lightly, and check for smoothly turn, roughness, binding or noise.
- ★ If roughness, binding or noise is found, remove the rear wheel (see Rear Wheel Removal in the Wheels/Tires chapter) and inspect the wheel bearing (see Hub Bearing Inspection in the Wheels/Tires chapter) and coupling (see Coupling Bearing Inspection in the Final Drive chapter).



Final Drive

Belt Deflection Inspection

NOTE

- Belt deflection must be checked and adjusted when the belt is cold (at room temperature).
- Belt deflection also should be checked at first 1 000 km ride after belt replacement.
- Check to see if wheel alignment is properly adjusted.
- The left and right notches on the belt adjuster should point to the same marks or positions on the swingarm.
- ★ If they do not, adjust wheel alignment (see Wheel Alignment Inspection/Adjustment).
- Remove the reserve tank cover (see Reserve Tank Removal in the Cooling System chapter).
- Raise the rear wheel off the ground with jack (see Rear Wheel Removal in the Wheels/Tires chapter).
- Visually inspect the belt for damage (see Belt Wear and Damage Inspection).
- ★ If the belt is damaged, replace it with a new one.
- Mark the initial belt position [A] on the belt cover window.



- Using the tension gauge [A], push up 45 N (4.6 kgf, 10 lb) of force from under and on the center of the belt at the front side of the swingarm cross pipe [B].

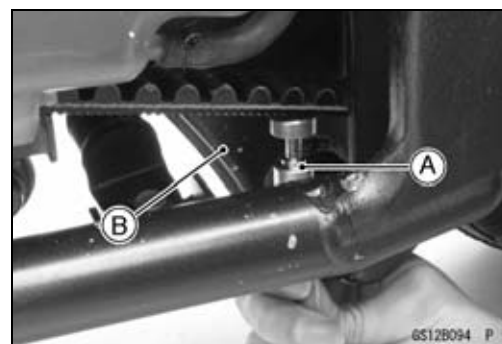

2-26 PERIODIC MAINTENANCE

Periodic Maintenance Procedures

- Measure the deflection (length between initial belt position [A] and position [B] that is pointed by the procedures above) of the belt (at the belt cover window).

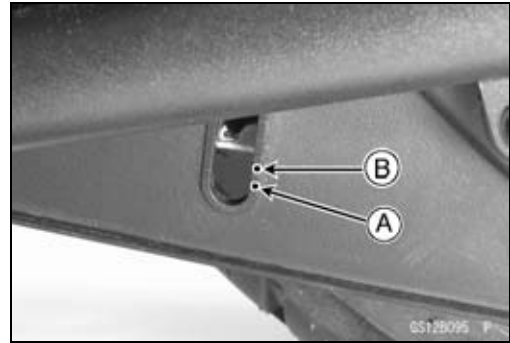

NOTE

- Push the belt by the gauge until the top surface [A] of the stopper comes to the 45 N loaded scale [B], marked "45N".
 - Push up on the center of the belt. An inaccurate reading will occur if the edge of the belt is pushed up.
 - Look parallel to the belt during inspection. An inaccurate reading will occur if looking from any other angle.
- Inspect the belt deflection at two positions by rotating the rear wheel.
- Special Tool - Tension Gauge: 57001-1585**
- Inspect the drive belt deflection at arbitrary position, and record the value [A].

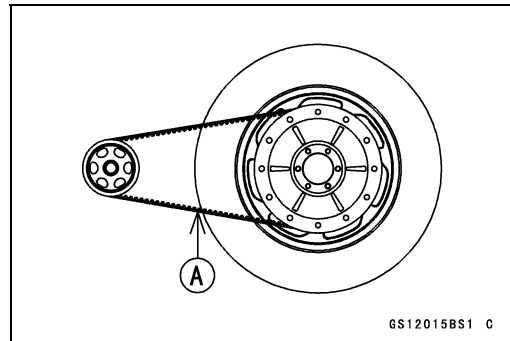
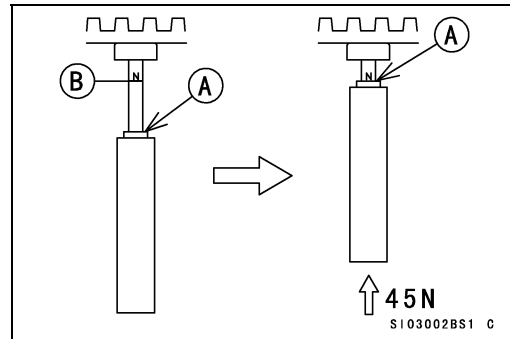

- Turn the rear wheel as shown in the figure. 90° [A]

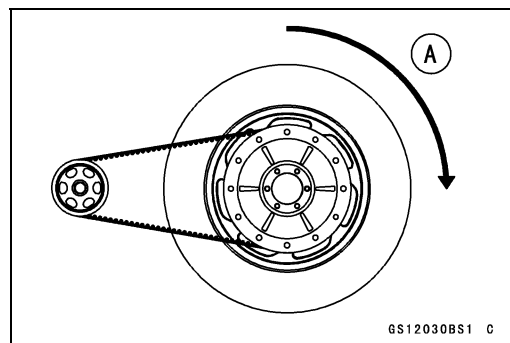

Periodic Maintenance Procedures

- Inspect the drive belt deflection, and record the value [B].

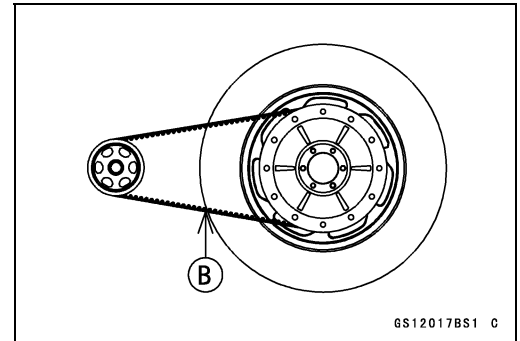

- Decide the belt deflection at the position [C] of one where deflection is large.

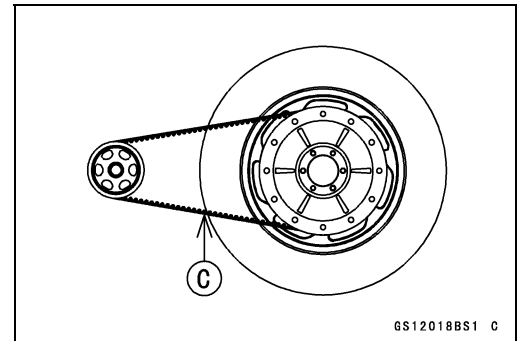

Drive Belt Deflection (with 45 N, 4.6 kgf, 10 lb force)
Standard: 1.5 ~ 4.0 mm (0.06 ~ 0.16 in.)

Drive Belt Deflection (with 45 N, 4.6 kgf, 10 lb force, when installing new belt or engine is remounted)
Standard: 1.5 mm (0.06 in.)

★ If the deflection is out of the specification, adjust it.

Belt Deflection Adjustment

- Remove the mufflers (see Muffler Removal in the Engine Top End chapter).
- Remove the axle cotter pin, and loosen the axle nut.
- Raise the rear wheel off the ground with jack (see Rear Wheel Removal in the Wheels/Tires chapter).
- Loosen the left and right belt adjuster locknuts [A].
- ★ If the belt is too tight, back out the left and right belt adjuster nuts [B], and kick the wheel forward until the belt is too loose.
- Turn in the left and right belt adjuster nuts evenly until the drive belt has the correct amount of deflection.
- To keep the belt and wheel aligned, the notch on the left belt adjuster should align with the same swingarm mark [C] that the right belt adjuster notch aligns with.

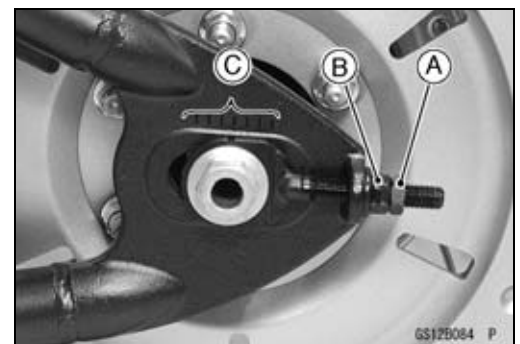

2-28 PERIODIC MAINTENANCE

Periodic Maintenance Procedures

- Tighten both belt adjuster locknuts.

⚠ WARNING

Misalignment of the wheel will result in abnormal wear, and may result in an unsafe riding condition. Tighten both belt adjuster locknuts, and make sure the axle stays aligned.

- Tighten the axle nut.
Torque - Rear Axle Nut: 108 N·m (11.0 kgf·m, 80 ft·lb)
- Inspect the drive belt deflection (see Belt Deflection Inspection).
- ★ Readjust if necessary.
- Insert a new cotter pin [A].

NOTE

- When inserting the cotter pin, if the slots in the nut do not align with the cotter pin hole in the axle, tighten the nut clockwise [B] up to next alignment.
- It should be within 30°.
- Loosen once and tighten again when the slot goes past the nearest hole.

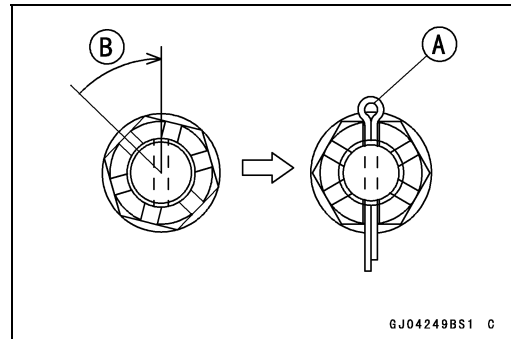

- Bend the cotter pin [A] over the nut [B].

⚠ WARNING

A loose axle nut can lead to an accident resulting in serious injury or death. Tighten the axle nut to the proper torque and install a new cotter pin.

- Check the rear brake for weak braking power and brake drag.

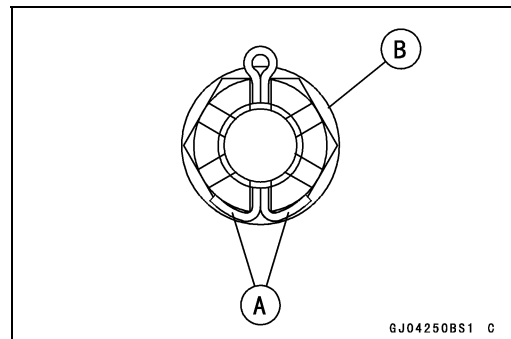

Wheel Alignment Inspection/Adjustment

- Check that the notch [A] on the left belt adjuster [B] aligns with the same swingarm mark [C] or position that the right belt adjuster notch aligns with.
- ★ If they do not, adjust the belt deflection (see Belt Deflection Adjustment) and align the wheel alignment.

NOTE

- Wheel alignment can be also checked using the straightedge or string method.

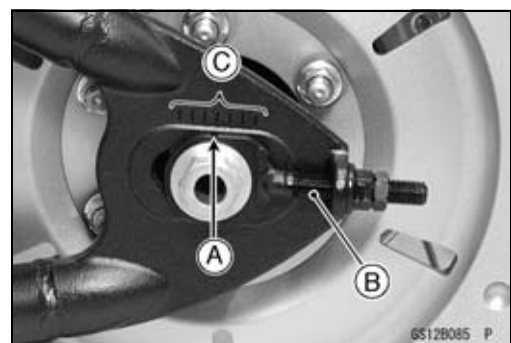

⚠ WARNING

Misalignment of the wheel will result in abnormal wear and may result in an unsafe riding condition. Be sure the wheel is properly aligned.

Periodic Maintenance Procedures

Belt Wear and Damage Inspection

- Raise the rear wheel off the ground with jack (see Rear Wheel Removal in the Wheels/Tires chapter).
- Remove:
 - Bolts [A] and Washers
 - Drive Belt Cover [B]

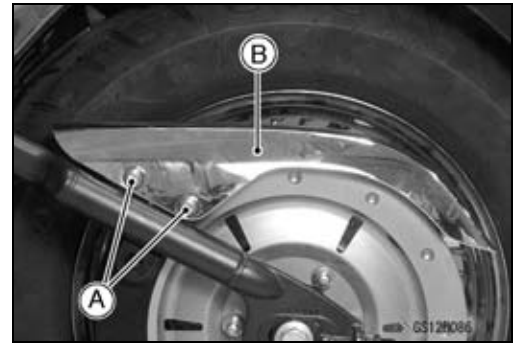

- Visually inspect the belt [A] for wear and damage.
- ★ If the nylon fabric facing of any portion is worn off, and the polyurethane compound is exposed, or belt is damaged, replace the belt immediately with a new one.
- Otherwise, refer to the Drive Belt Tooth Wear Patterns and perform the according to the table of Drive Belt Wear Analysis.
- ★ Whenever the belt is replaced, inspect the engine and rear pulleys (see Pulley Wear Inspection in the Final Drive chapter).

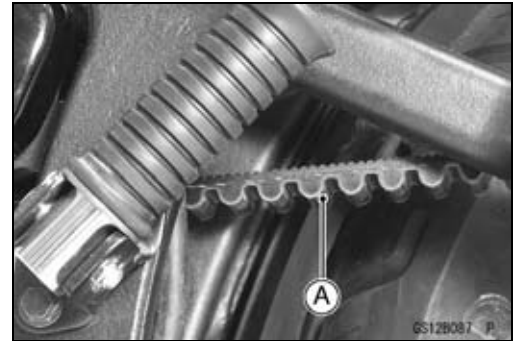

⚠ WARNING

A drive belt worn past the nylon fabric facing may break and cause an accident resulting in serious injury or death. Replace any drive belt worn beyond the service limits.

2-30 PERIODIC MAINTENANCE

Periodic Maintenance Procedures

Drive Belt Tooth Wear and Damage Patterns

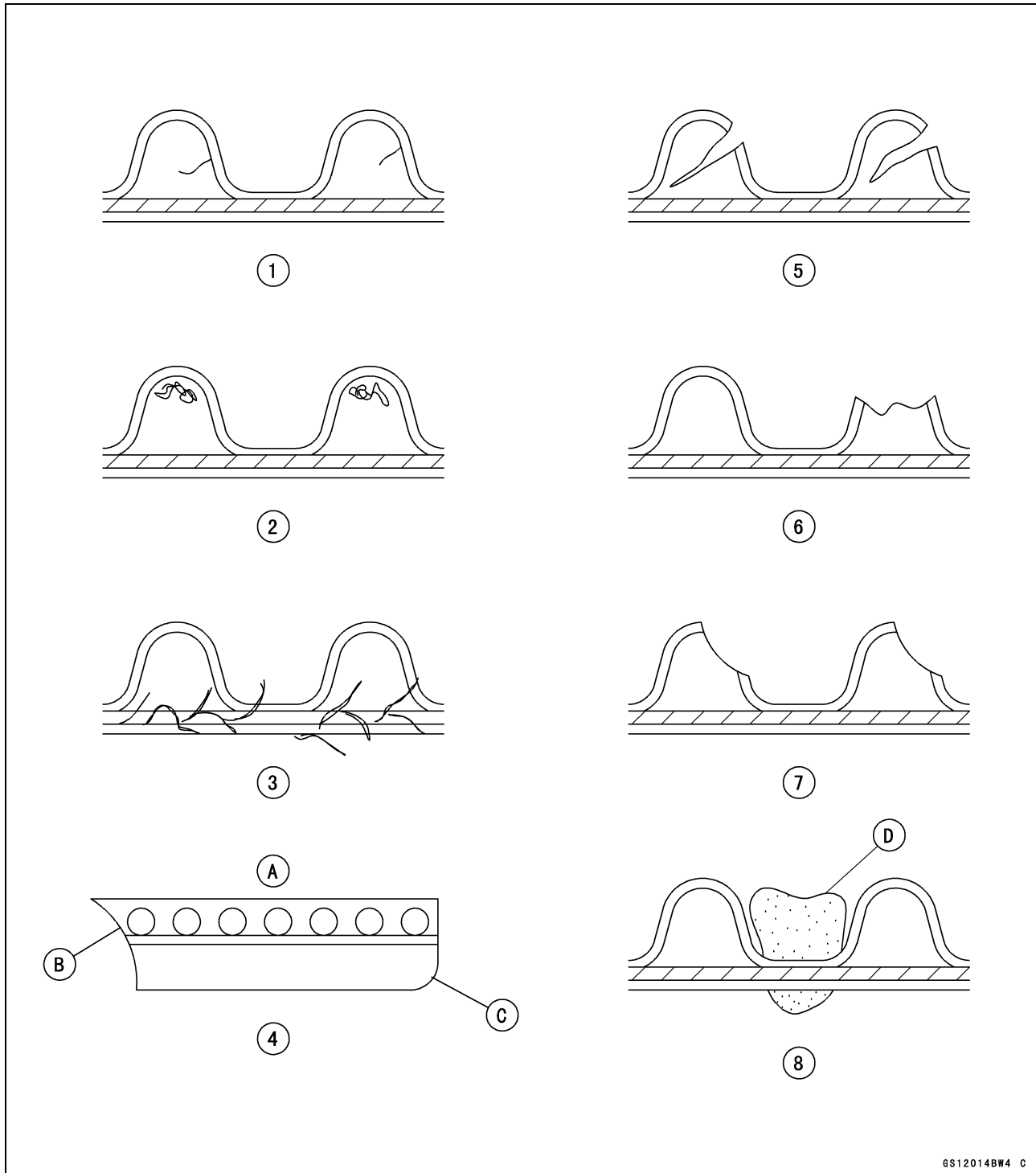

- A. Belt Cross Section
- B. Edge Bevel Wear
- C. Rub Wear
- D. Stone

Periodic Maintenance Procedures

Drive Belt Wear and Damage Analysis

| Pattern | Condition | Required Action |
|---------|-----------------------------------|---|
| 1 | Internal tooth cracks (slight) | O.K. for continued use, but inspect the belt periodically. |
| 2 | Scuffing to side of teeth | O.K. for continued use, but inspect the belt periodically. Also check the pulley flange. |
| 3 | Fraying edge cord | O.K. for continued use, but inspect the belt periodically (replace the belt if excessive). |
| 4 | Beveled wear | O.K. for continued use, check the pulley alignment and flange condition. |
| 5 | External tooth cracks (severe) | Replace the drive belt. |
| 6 | Severe fractured or missing teeth | Replace the drive belt. |
| 7 | Tooth hook wear | Replace the drive belt. Inspect the pulley for wear. |
| 8 | Stone damage | Remove stone, O.K. for continued use if not near edge of the belt. Inspect the pulley for damage. |

Brake System

Brake Fluid Leak (Brake Hose and Pipe) Inspection

- Apply the brake lever or pedal and inspect the brake fluid leak from the brake hoses [A] and fittings [B].
- ★ If the brake fluid leaked from any position, inspect or replace the problem part.

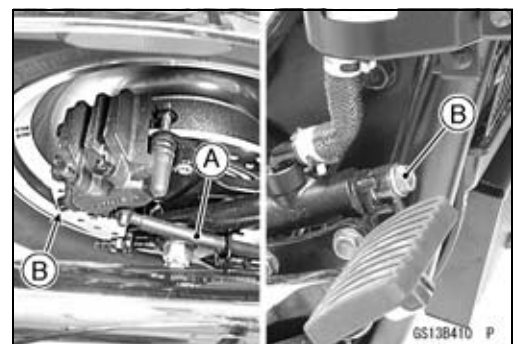
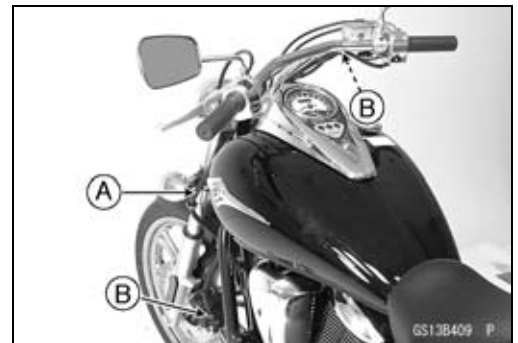

2-32 PERIODIC MAINTENANCE

Periodic Maintenance Procedures

Brake Hose and Pipe Damage and Installation Condition Inspection

- Inspect the brake hoses and fittings for deterioration, cracks and signs of leakage.
- The high pressure inside the brake line can cause fluid to leak [A] or the hose to burst if the line is not properly maintained. Bend and twist the rubber hose while examining it.
- ★ Replace the hose if any crack [B], bulge [C] or leakage is noticed.
- ★ Tighten any brake hose banjo bolts.

Torque - Brake Hose Banjo Bolts: 25 N·m (2.5 kgf·m, 18 ft·lb)

- Inspect the brake hose routing.
- ★ If any brake hose routing is incorrect, route the brake hose according to Cable, Wire, and Hose Routing section in the Appendix chapter.

Brake Operation Inspection

- Inspect the operation of the front and rear brake by running the vehicle on the dry road.
- ★ If the brake operation is insufficiency, inspect the brake system.

⚠ WARNING

When test riding the vehicle, be aware of surrounding traffic for your safety.

Brake Fluid Level Inspection

- Check that the brake fluid level in the front brake reservoir [A] is above the lower level line [B].

NOTE

○ Hold the reservoir horizontal by turning the handlebar when checking brake fluid level.

- ★ If the fluid level is lower than the lower level line, fill the reservoir to the upper level line [C] in the reservoir.
- Tighten:

Torque - Front Brake Reservoir Cap Screws: 1.5 N·m (0.15 kgf·m, 13 in·lb)

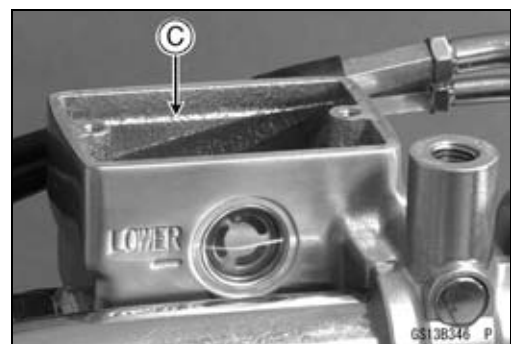
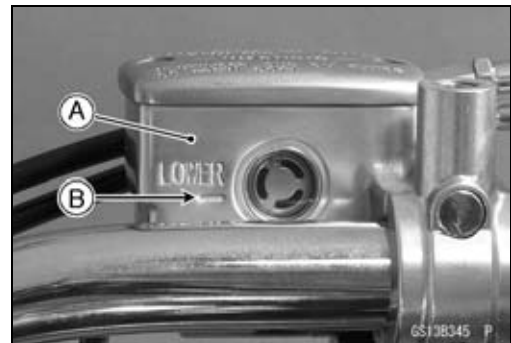
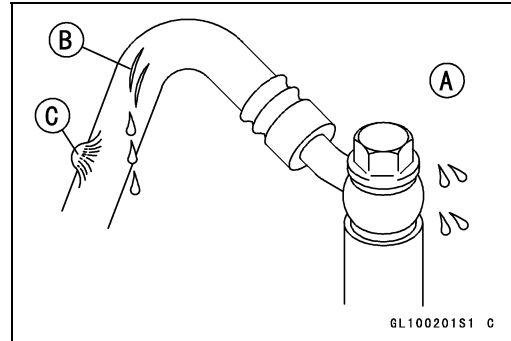

Periodic Maintenance Procedures

- Check that the brake fluid level in the rear brake reservoir [A] is above the lower level line [B].
- ★ If the fluid level is lower than the lower level line, fill the reservoir to the upper level line [C].

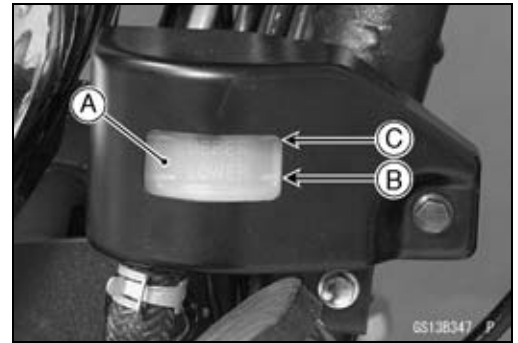

⚠ WARNING

Mixing brands and types of brake fluid can reduce the brake system's effectiveness and cause an accident resulting in injury or death. Do not mix two brands of brake fluid. Change the brake fluid in the brake line completely if the brake fluid must be re-filled but the type and brand of the brake fluid that is already in the reservoir are unidentified.

Recommended Disc Brake Fluid
Grade: DOT4

- Follow the procedure below to install the rear brake fluid reservoir cap correctly.
- First, tighten the rear brake fluid reservoir cap [B] clockwise [C] by hand until slight resistance is felt indicating that the cap is seated on the reservoir body, then tighten the cap an additional 1/6 turn [D] while holding the brake fluid reservoir body [A].

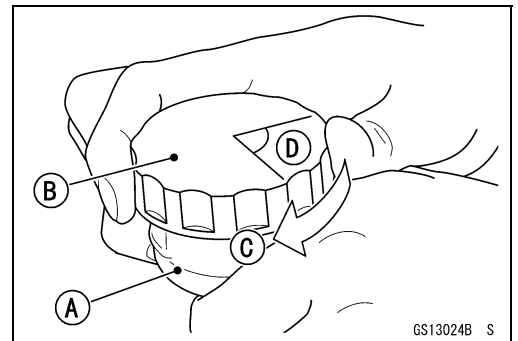

Brake Pad Wear Inspection

- Check the lining thickness [A] of the pads in each caliper.
- ★ If the lining thickness of either pad is less than the service limit [B], replace both pads in the caliper as a set.

Pad Lining Thickness
Standard:

Front 4.5 mm (0.18 in.)
Rear 7.0 mm (0.28 in.)

Service Limit: 1 mm (0.04 in.)

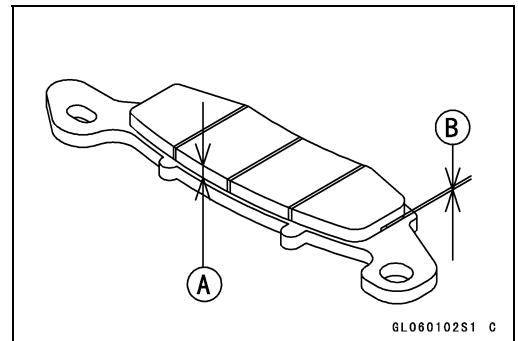

Brake Light Switch Operation Inspection

- Turn on the ignition switch.
- The brake light [A] should go on when the brake lever is applied or after the brake pedal is depressed about 10 mm (0.39 in.).

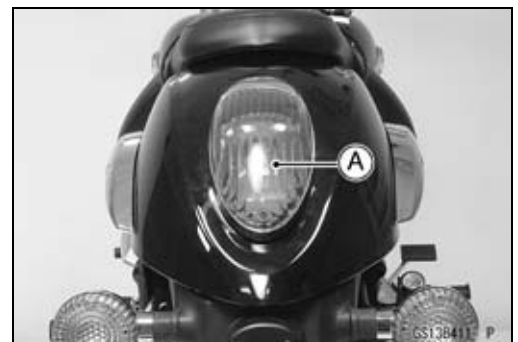

2-34 PERIODIC MAINTENANCE

Periodic Maintenance Procedures

- ★ If it does not, adjust the brake light switch.
- While holding the switch body, turn the adjusting nut [A] to adjust the switch.

NOTICE

To avoid damaging the electrical connections inside the switch, be sure that the switch body does not turn during adjustment.

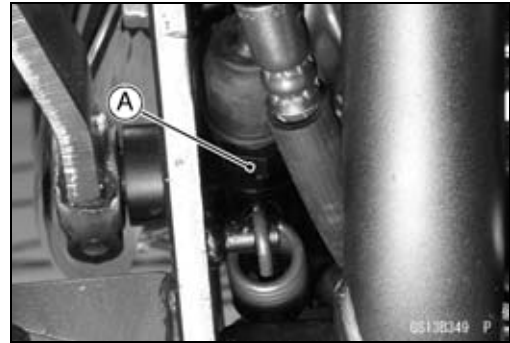

- ★ If it does not go on, inspect or replace the following items.
 - Battery (see Charging Condition Inspection in the Electrical System chapter)
 - Brake Light (see Tail/Brake Light Removal/Installation in the Electrical System chapter)
 - Main Fuse 30 A and Taillight Fuse 10 A (see Fuse Inspection in the Electrical System chapter)
 - Front Brake Light Switch [A] (see Switch Inspection in the Electrical System chapter)
 - Rear Brake Light Switch (see Switch Inspection in the Electrical System chapter)
 - Harness (see Wiring Inspection in the Electrical System chapter)

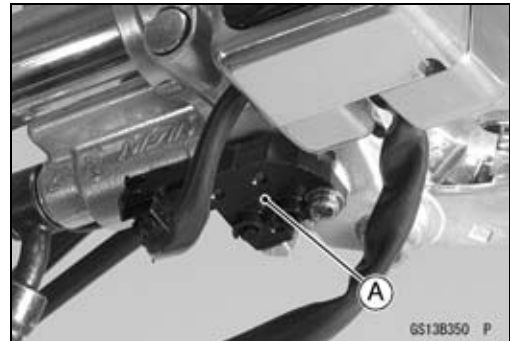

Suspensions

Front Forks/Rear Shock Absorber Operation Inspection

- Pump the forks down and up [A] 4 or 5 times, and inspect the smooth stroke.
- ★ If the forks do not smoothly stroke or noise is found, inspect the fork oil level or fork clamps (see Front Fork Oil Change in the Suspension chapter).
- Pump the seat down and up [A] 4 or 5 times, and inspect the smooth stroke.
- ★ If the shock absorber does not smoothly stroke or noise is found, inspect the oil leak (see Rear Shock Absorber Oil Leak Inspection).

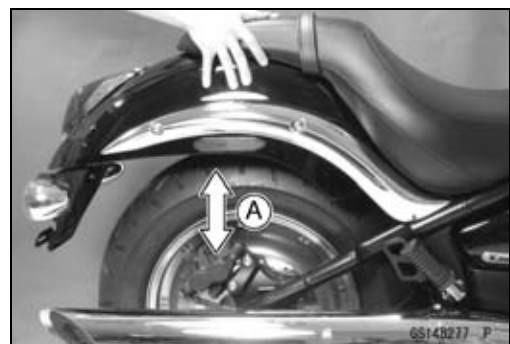
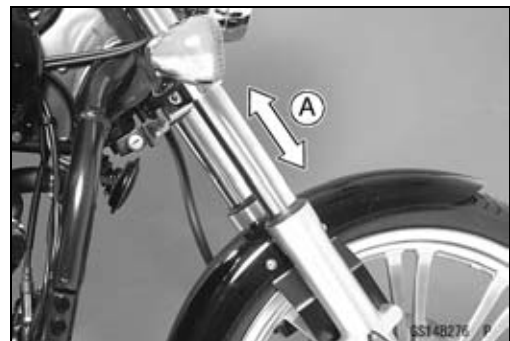

Periodic Maintenance Procedures

Front Fork Oil Leak Inspection

- Visually inspect the front forks [A] for oil leakage.
- ★ Replace any defective parts, if necessary.

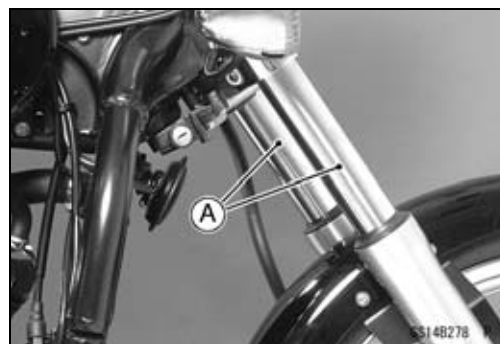

Rear Shock Absorber Oil Leak Inspection

- Remove the left side cover (see Left Side Cover Removal in the Frame chapter).
- Visually inspect the shock absorber [A] for oil leakage.
- ★ If the oil leakage is found on it, replace the shock absorber with a new one.



Swingarm Pivot Lubrication

- Remove the swingarm (see Swingarm Removal in the Suspension chapter).
- Clean the old grease out of the bearings.
- Apply grease to the inner surface of the needle bearings [A].
- Apply a thin coat of grease to the lips of the grease seals.
- Install the swingarm (see Swingarm Installation in the Suspension chapter).



Rocker Arm Operation Inspection

- Pump the seat down and up 4 or 5 times, and inspect the smooth stroke.
- ★ If the rocker arm [A] does not smoothly stroke or noise is found, inspect the fasteners and bearings.

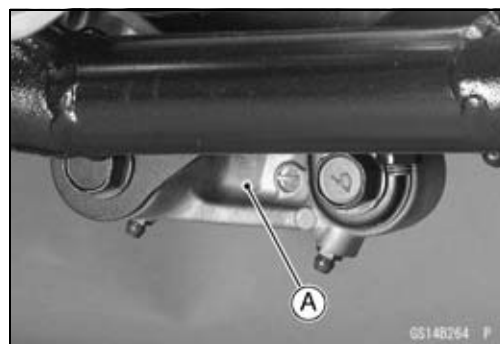

Tie-Rod Operation Inspection

- Pump the seat down and up 4 or 5 times, and inspect the smooth stroke.
- ★ If the tie-rod [A] do not smoothly stroke or noise is found, inspect the fasteners and tie-rod bearings.



2-36 PERIODIC MAINTENANCE

Periodic Maintenance Procedures

Uni-trak Linkage Lubrication

- Remove the tie-rod (see Tie-Rod Removal in the Suspension chapter).
- Apply grease to the inner surfaces of the needle bearings [A].

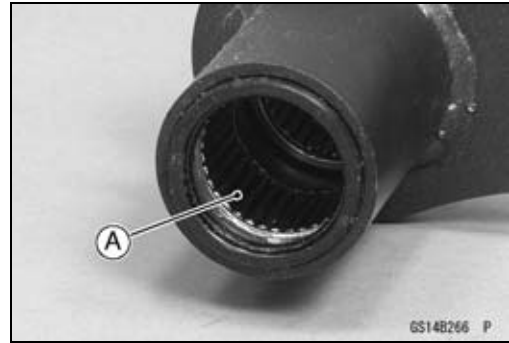

VN900C7 ~ C9 Models

- For the rocker arm it has grease nipples [A] on the rocker arm for lubrication. Force grease into the nipple until it comes out both sides of the rocker arm, and wipe off any excess.
- Apply a thin coat of grease to the lips of the grease seals.

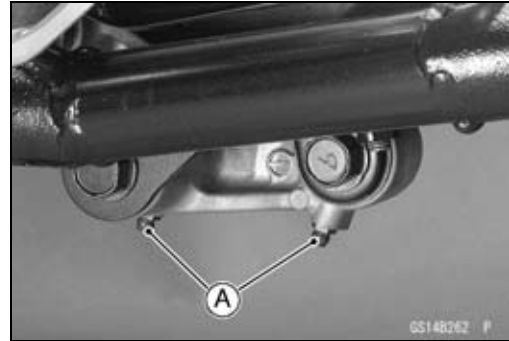

Steering System

Steering Play Inspection

- Raise the front wheel off the ground with jack (see Front Wheel Removal in the Wheels/Tires chapter).
- With the front wheel pointing straight ahead, alternately tap each end of the handlebar. The front wheel should swing fully left and right from the force of gravity until the fork hits the stop.
- ★ If the wheel binds or catches before the stop, the steering is too tight.
- Feel for steering looseness by pushing and pulling the forks.
- ★ If you feel looseness, the steering is too loose.



NOTE

- The cables and wiring will have some effect on the motion of the fork which must be taken into account.
- Be sure the wires and cables are properly routed.
- The bearings must be in good condition and properly lubricated in order for any test to be valid.

Steering Play Adjustment

- Remove:
Upper Front Fork Clamp Bolts (Both Sides) [A]
Steering Stem Head Nut [B] and Washer
Steering Stem Head [C] with Handlebar

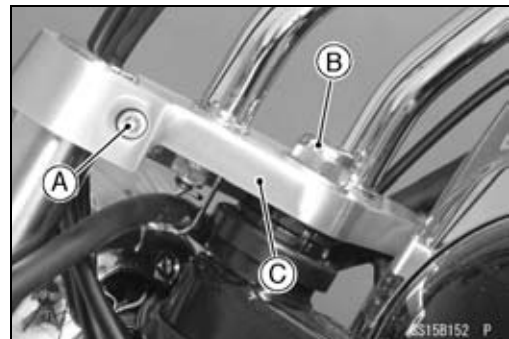

Periodic Maintenance Procedures

- Bend the claws [A] of the claw washer straighten.
- Remove the steering stem locknut [B] and claw washer [C].

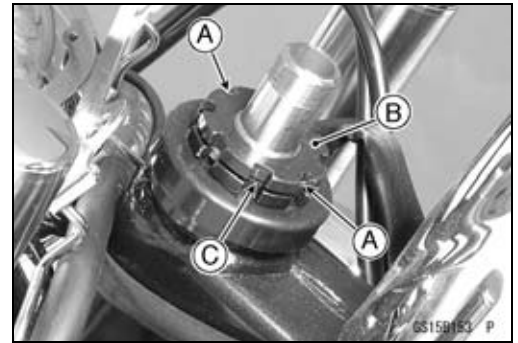

- Adjust the steering.
 - Special Tool - Steering Stem Nut Wrench [A]: 57001-1100**
 - ★ If the steering is too tight, loosen the stem nut [B] a fraction of a turn.
 - ★ If the steering is too loose, tighten the stem nut a fraction of a turn.

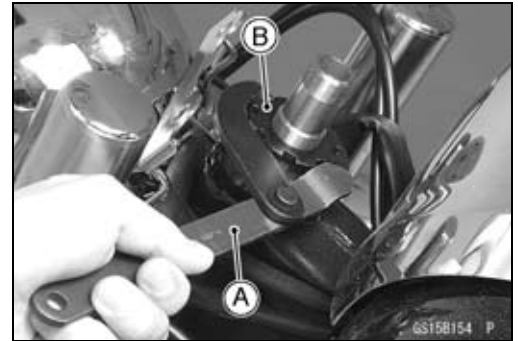

NOTE

○ Turn the stem nut 1/8 turn at time maximum.

- Replace the claw washer with a new one.
- Install the claw washer [A] so that its bent side [B] faces upward, and engage the bent claws with the grooves of stem locknut [C].
- Hand tighten the stem locknut until it touches the claw washer.
- Tighten the stem locknut clockwise until the claws are aligned with the grooves (ranging from 2nd to 4th) of stem nut [D], and bend the 2 claws downward [E].
- Install the steering stem head.
- Install the washer, and tighten the stem head nut.
- Tighten:

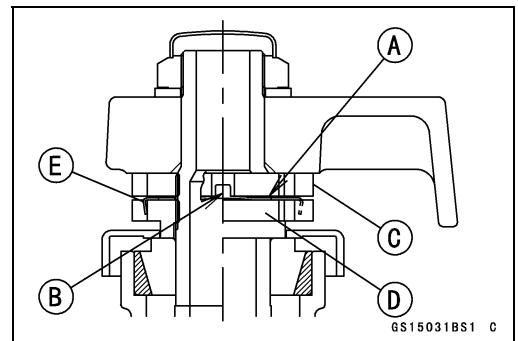

Torque - Steering Stem Head Nut: 49 N·m (5.0 kgf·m, 36 ft·lb)

Front Fork Clamp Bolts (Upper): 20 N·m (2.0 kgf·m, 15 ft·lb)

- Check the steering again.
- ★ If the steering is still too tight or too loose, repeat the adjustment.

Steering Stem Bearing Lubrication

- Remove the steering stem (see Steering Stem Removal in the Steering chapter).
- Using a high flash-point solvent, wash the upper and lower tapered roller bearings in the cages, and wipe the upper and lower outer races, which are press-fitted into the frame head pipe, clean off grease and dirt.
- Visually check the outer races and the rollers.
- ★ Replace the bearing assemblies if they show wear or damage.
- Pack the upper and lower [A] tapered roller bearings in the cages with grease, and apply a light coat of grease to the upper and lower outer races.
- Install the steering stem (see Steering Stem Installation in the Steering chapter).
- Adjust the steering (see Steering Play Adjustment).

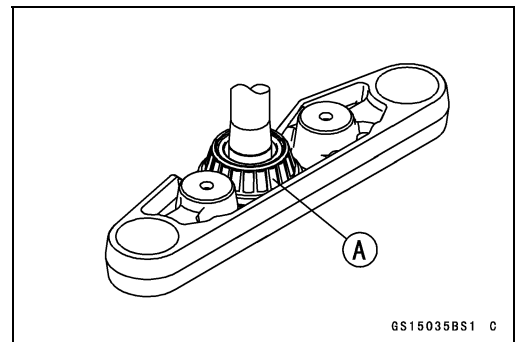

2-38 PERIODIC MAINTENANCE

Periodic Maintenance Procedures

Electrical System

Spark Plug Condition Inspection

- Refer to the Spark Plug Condition Inspection in the Periodic Maintenance chapter.

Lights and Switches Operation Inspection

First Step

- Turn on the ignition switch.
- The following lights should go on according to below table.

| | |
|--|------------------------------|
| Position Lights [A] (US and CA Models) | goes on |
| City Light [B] (EUR, SEA-B1 (VN900CC ~), SEA-B3 (VN900CE), BR and PH Models) | goes on |
| Taillight [C] | goes on |
| License Plate Light [D] | goes on |
| Neutral Indicator Light [E] | goes on |
| Oil Pressure Warning Indicator Light (LED) [F] | goes on |
| FI Indicator Light (LED) [G] | goes on (about 2 seconds) |

- ★ If the light does not go on, inspect or replace the following item.

Battery (see Charging Condition Inspection in the Electrical System chapter)

Applicable Bulb (see Wiring Diagram section in the Electrical System chapter)

Meter Unit for Neutral Indicator Light (see Meter Unit Inspection in the Electrical System chapter)

Meter Unit for Oil Pressure Warning Indicator Light (LED) (see Meter Unit Inspection in the Electrical System chapter)

Meter Unit for FI Indicator Light (LED) (see Meter Unit Inspection in the Electrical System chapter)

ECU (see ECU Power Supply Inspection in the Fuel System (DFI) chapter)

Main Fuse 30 A and Taillight Fuse 10 A (see Fuse Inspection in the Electrical System chapter)

Ignition Switch (see Switch Inspection in the Electrical System chapter)

Neutral Switch (see Switch Inspection in the Electrical System chapter)

Harness (see Wiring Inspection in the Electrical System chapter)

- Turn off the ignition switch.
- The all lights should go off.
- ★ If the light does not go off, replace the ignition switch.

Second Step

- Turn the ignition switch to P (Park) position.
- The city light, taillight and license plate light should go on.
- ★ If the light does not go on, inspect or replace the following item.

Ignition Switch (see Switch Inspection in the Electrical System chapter)

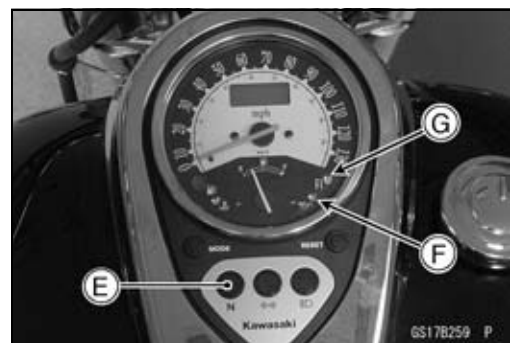

Periodic Maintenance Procedures

Third Step

- Turn on the turn signal switch [A] (left or right position).
- The left or right turn signal lights [B] (front and rear) according to the switch position should flash.
- The turn signal indicator light [C] in the meter unit should flash.

★ If the each light does not flash, inspect or replace the following item.

Turn Signal Light Bulb (see Turn Signal Light Bulb Replacement in the Electrical System chapter)

Meter Unit for Turn Signal Light Indicator Light (see Meter Unit Inspection in the Electrical System chapter)

Turn Signal Relay Fuse 10 A (see Fuse Inspection in the Electrical System chapter)

Turn Signal Switch (see Switch Inspection in the Electrical System chapter)

Turn Signal Relay (see Turn Signal Relay Inspection in the Electrical System chapter)

Harness (see Wiring Inspection in the Electrical System chapter)

- Push the turn signal switch.
- The turn signal lights and indicator light should go off.
- ★ If the light does not go off, inspect or replace the following item.

Turn Signal Switch (see Switch Inspection in the Electrical System chapter)

Turn Signal Relay (see Turn Signal Relay Inspection in the Electrical System chapter)

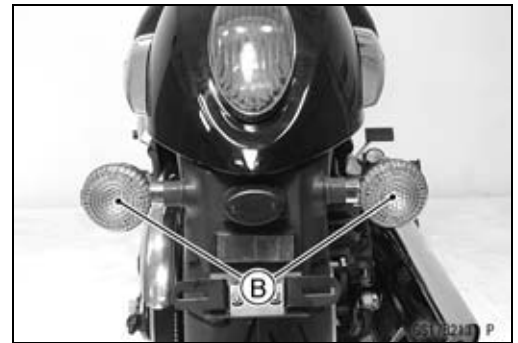
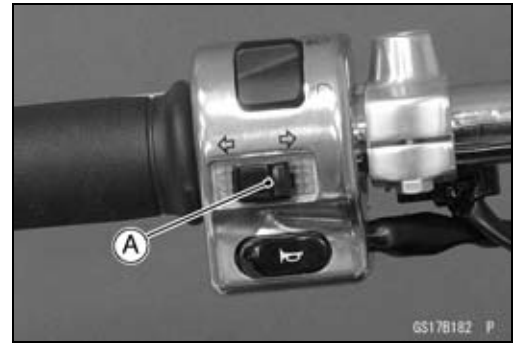

Fourth Step

- Set the dimmer switch [A] to low beam position.
- Start the engine.
- The low beam should go on.
- ★ If the low beam does not go on, inspect or replace the following item.

Headlight Low Beam Bulb (see Headlight Bulb Replacement in the Electrical System chapter)

Headlight Fuse 10 A (see Fuse Inspection in the Electrical System chapter)

Dimmer Switch (see Switch Inspection in the Electrical System chapter)

Headlight Relay in Relay Box (see Relay Circuit Inspection in the Electrical System chapter)

Harness (see Wiring Inspection in the Electrical System chapter)

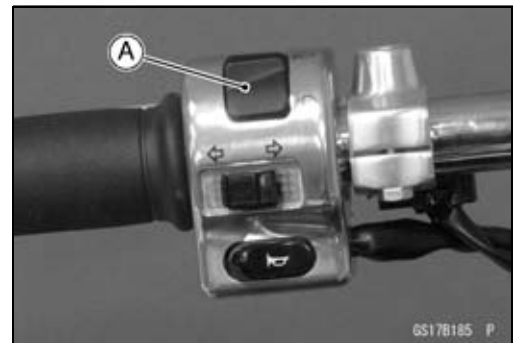

2-40 PERIODIC MAINTENANCE

Periodic Maintenance Procedures

- Set the dimmer switch to high beam position.
- The high beam should go on.
- The high beam indicator light [A] should go on.
- ★ If the high beam headlight and/or high beam indicator light does not go on, inspect or replace the following item.
 - Headlight Bulb (see Headlight Bulb Replacement in the Electrical System chapter)
 - Dimmer Switch (see Switch Inspection in the Electrical System chapter)
- Turn off the engine stop switch.
- The high beam should stay going on.
- ★ If the headlight and high beam indicator light does go off, inspect or replace the following item.
 - Headlight Relay in Relay Box (see Relay Circuit Inspection in the Electrical System chapter)
- Turn off the ignition switch.
- The headlight and high beam indicator light should go off.



Headlight Aiming Inspection

- Inspect the headlight beam for aiming.
- ★ If the headlight beam points to one side rather than straight ahead, adjust the horizontal beam.

Headlight Beam Horizontal Adjustment

- Turn the horizontal adjuster [A] on the headlight with the screwdriver in or out until the beam points straight ahead.
- ★ If the headlight beam points too low or high, adjust the vertical beam.



Headlight Beam Vertical Adjustment

- Turn the vertical adjuster [A] on the headlight with the screwdriver in or out to adjust the headlight vertically.



Periodic Maintenance Procedures

NOTE

- ON high beam, the brightest points should be slightly below horizontal with the motorcycle on its wheels and the rider seated. Adjust the headlight to the proper angle according to local regulations.
- For US model, the proper angle is 0.4 degrees below horizontal. This is 50 mm (2 in.) drop at 7.6 m (25 ft) measured from the center of the headlight with the motorcycle on its wheels and the rider seated.

50 mm (2 in.) [A]
 Center of Brightest Spot [B]
 7.6 m (25 ft) [C]

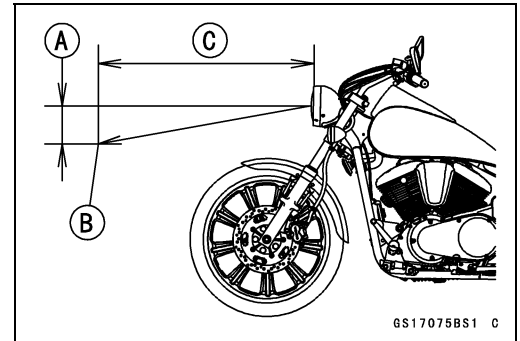

Sidestand Switch Operation Inspection

- Inspect the sidestand switch [A] operation accordance to below table.

Sidestand Switch Operation

| Sidestand | Gear Position | Clutch Lever | Engine Start | Engine Run |
|-----------|---------------|--------------|---------------|------------------|
| Up | Neutral | Released | Starts | Continue running |
| Up | Neutral | Pulled in | Starts | Continue running |
| Up | In Gear | Released | Doesn't start | Continue running |
| Up | In Gear | Pulled in | Starts | Continue running |
| Down | Neutral | Released | Starts | Continue running |
| Down | Neutral | Pulled in | Starts | Continue running |
| Down | In Gear | Released | Doesn't start | Stops |
| Down | In Gear | Pulled in | Doesn't start | Stops |



2-42 PERIODIC MAINTENANCE

Periodic Maintenance Procedures

★ If the sidestand switch operation does not work, inspect or replace the following item.

Battery (see Charging Condition Inspection in the Electrical System chapter)

Main Fuse 30 A (see Fuse Inspection in the Electrical System chapter)

Ignition Fuse 10 A (see Fuse Inspection in the Electrical System chapter)

Ignition Switch (see Switch Inspection in the Electrical System chapter)

Sidestand Switch (see Switch Inspection in the Electrical System chapter)

Engine Stop Switch (see Switch Inspection in the Electrical System chapter)

Starter Button (see Switch Inspection in the Electrical System chapter)

Neutral Switch (see Switch Inspection in the Electrical System chapter)

Starter Relay (see Starter Relay Inspection in the Electrical System chapter)

Relay Box (see Relay Circuit Inspection in the Electrical System chapter)

Starter Circuit Relay (see Relay Circuit Inspection in the Electrical System chapter)

Harness (see Wiring Inspection in the Electrical System chapter)

★ If all parts are in good condition, replace the ECU.

Engine Stop Switch Operation Inspection

First Step

- Turn on the ignition switch.
 - Set the neutral position.
 - Turn the engine stop switch to stop position [A].
 - Push the starter button.
 - The engine does not start.
- ★ If the engine starts, inspect or replace the following item.
- Engine Stop Switch (see Switch Inspection in the Electrical System chapter)

Second Step

- Turn on the ignition switch.
 - Set the neutral position.
 - Turn the engine stop switch to run position [A].
 - Push the starter button and run the engine.
 - Turn the engine stop switch to stop position.
 - Immediately the engine should stop.
- ★ If the engine does not stop, inspect or replace the following item.
- Engine Stop Switch (see Switch Inspection in the Electrical System chapter)
- ★ If the engine stop switch is in good condition, replace the ECU.

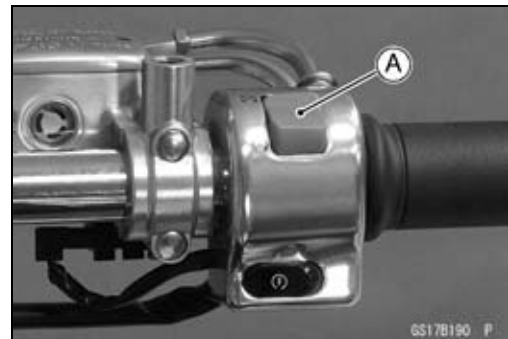

Periodic Maintenance Procedures

Others

Chassis Parts Lubrication

- Before lubricating each part, clean off any rusty spots with rust remover and wipe off any grease, oil, dirt, or grime.
- Lubricate the points listed below with indicated lubricant.

NOTE

○Whenever the vehicle has been operated under wet or rainy conditions, or especially after using a high-pressure water spray, perform the general lubrication.

Pivots: Lubricate with Grease.

- Brake Lever
- Brake Pedal
- Clutch Lever
- Rear Brake Joint Pin
- Sidestand

Points: Lubricate with Grease.

- Clutch Inner Cable Upper and Lower Ends [A]
- Throttle Inner Cable Upper and Lower Ends

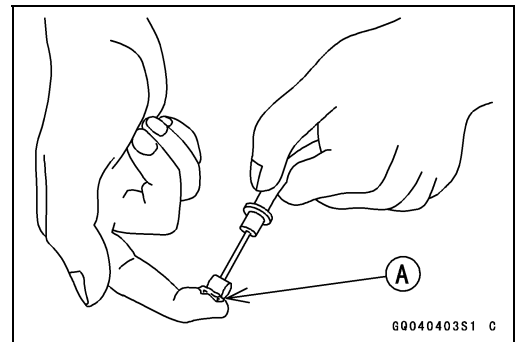

Cables: Lubricate with Rust Inhibitor.

- Clutch Cable
- Throttle Cables

- Lubricate the cables by seeping the oil between the cable and housing.
- The cable may be lubricated by using a commercially available pressure cable lubricator with an aerosol cable lubricant.

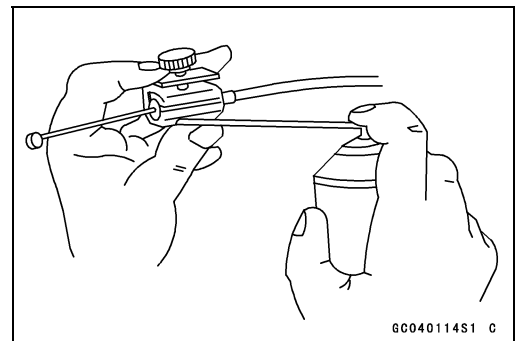

- With the cable disconnected at both ends, the inner cable should move freely [A] within the cable housing.
- ★ If cable movement is not free after lubricating, if the cable is frayed [B], or if the cable housing is kinked [C], replace the cable.

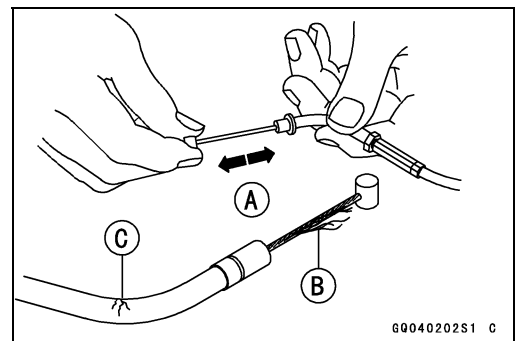

2-44 PERIODIC MAINTENANCE

Periodic Maintenance Procedures

Bolts, Nuts and Fasteners Tightness Inspection

- Check the tightness of the bolts and nuts listed here. Also, check to see that each cotter pin is in place and in good condition.

NOTE

○ *For the engine fasteners, check the tightness of them when the engine is cold (at room temperature).*

- ★ If there are loose fasteners, retighten them to the specified torque following the specified tightening sequence. Refer to the appropriate chapter for torque specifications. If torque specifications are not in the appropriate chapter, see the Standard Torque Table. For each fastener, first loosen it by 1/2 turn, then tighten it.
- ★ If cotter pins are damaged, replace them with new ones.

Bolt, Nut and Fastener to be checked

Engine:

- Clutch Lever Pivot Nut
- Engine Mounting Bolts and Nuts
- Exhaust Pipe Holder Nuts
- Muffler Mounting Bolts and Nut

Wheels:

- Front Axle Nut
- Front Axle Clamp Bolt
- Rear Axle Nut
- Rear Axle Nut Cotter Pin

Brakes:

- Brake Lever Pivot Nut
- Brake Pedal Clamp Bolt
- Brake Rod Joint Cotter Pin
- Caliper Mounting Bolts
- Front Master Cylinder Clamp Bolts
- Rear Master Cylinder Mounting Bolts

Suspension:

- Front Fork Clamp Bolts
- Rear Shock Absorber Bolts and Nuts
- Swingarm Pivot Shaft Nut

Steering:

- Steering Stem Head Nut
- Handlebar Mounting Nuts

Others:

- Footpeg Bracket Bolts (Front)
- Footpeg Bracket Bolts (Rear)
- Sidestand Mounting Bolt
- Downtube Bolts

Periodic Maintenance Procedures

Replacement Parts

Air Cleaner Element Replacement

⚠ WARNING

If dirt or dust is allowed to pass through into the throttle body assy, the throttle may become stuck, possibly causing accident.
 Replace the air cleaner element according to the maintenance chart.

NOTICE

If dirt gets through into the engine, excessive engine wear and possibly engine damage will occur.

- Remove:
 - Air Cleaner Cover Bolts [A]
 - Air Cleaner Cover [B]



- Unscrew the air cleaner element screw [A] and remove the air cleaner element [B].
- Discard the air cleaner element.

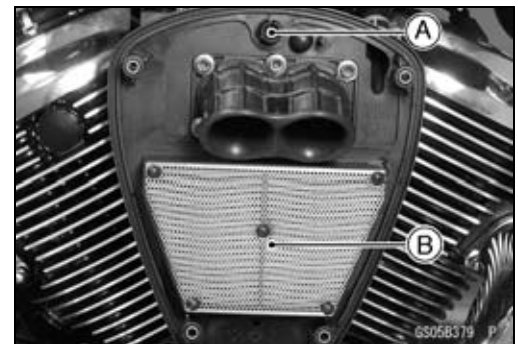

- Install a new element [A] with the mesh side facing upward.

NOTICE

Use only the recommended air cleaner element (Kawasaki part number 11013-0015). Using another air cleaner element will wear the engine prematurely or lower the engine performance.



- Install the removed parts (see appropriate chapters).

2-46 PERIODIC MAINTENANCE

Periodic Maintenance Procedures

Fuel Hose Replacement

NOTICE

When removing and installing the fuel hose joint, do not apply strong force to the outlet pipe on the fuel pump and delivery pipe on the throttle body assy. The pipes made from resin could be damaged.

- Remove the fuel tank (see Fuel Tank Removal in the Fuel System (DFI) chapter).
- Be sure to place a piece of cloth around the fuel hose joint.
- Wipe off the dirt of the surface [A] around the connection using a cloth or a soft brush.

When removing with standard tip screwdriver

- Insert the standard tip screwdriver [A] into the slit on the joint lock [B].
- Turn the driver to disconnect the joint lock.

When removing with fingers

- Open and push up [C] the joint lock with your fingers.

NOTICE

Prying or excessively widening the joint lock ends for fuel hose removal will permanently deform the joint lock, resulting in a loose or incomplete lock that may allow fuel to leak and create the potential for a fire explosion. To prevent fire or explosion from a damaged joint lock, do not pry or excessively widen the joint lock ends when removing the fuel hose. The joint lock has a retaining edge that locks around the housing.

- Pull [A] the fuel hose joint [B] out of the delivery pipe.
- Clean the delivery pipe.
- Cover the delivery pipe with the vinyl bag to keep it clean.

⚠ WARNING

Fuel is flammable and explosive under certain conditions and can cause severe burns. Be prepared for fuel spillage; any spilled fuel must be completely wiped up immediately. When the fuel hose is disconnected, fuel spills out from the hose and the pipe. Cover the hose connection with a clean shop towel to prevent fuel spillage.

- Remove the vinyl bag on the pipe.
- Check that there are no flaws, burrs, and adhesion of foreign materials on the delivery pipe [A].
- Replace the fuel hose with a new one.

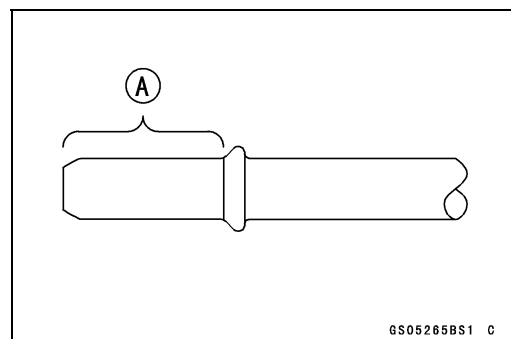
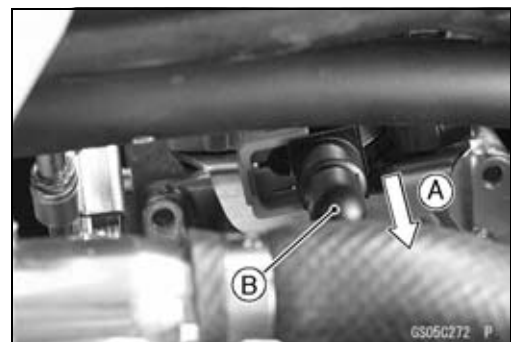
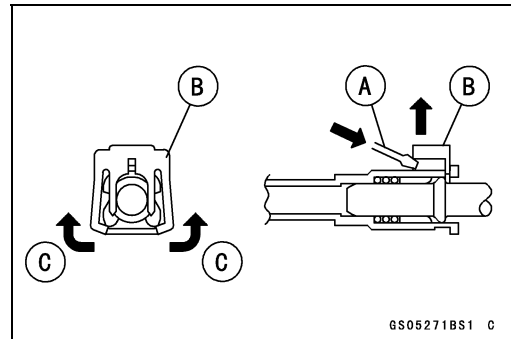
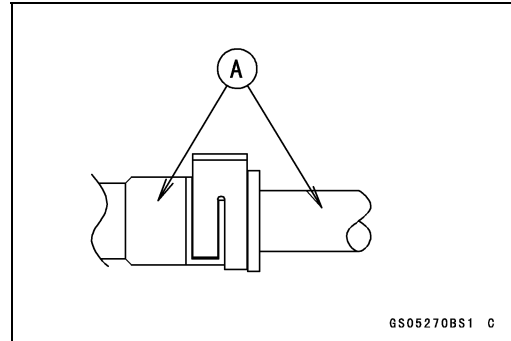

Periodic Maintenance Procedures

- Insert the fuel hose joint [A] straight onto the delivery pipe.
- Push [B] the joint lock [C] until the hose joint clicks.

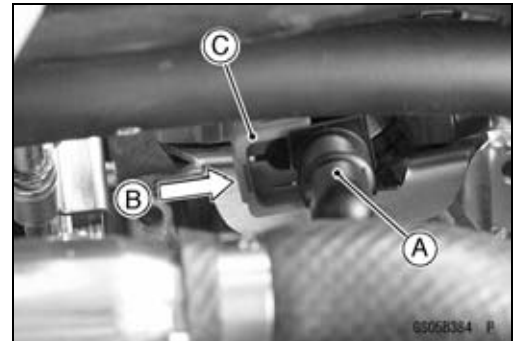

- Push and pull [A] the fuel hose joint [B] back and forth more than two times and make sure it is locked and doesn't come off.

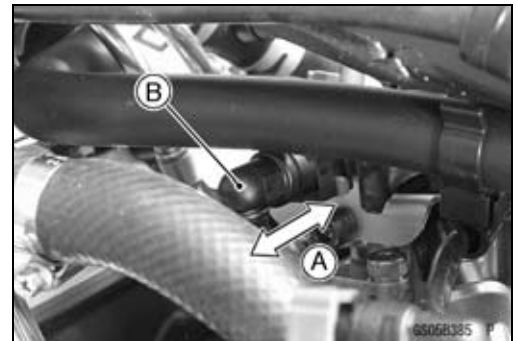

⚠ WARNING

Leaking fuel can cause a fire or explosion resulting in severe burns. Make sure the fuel hose joint is installed correctly on the delivery pipe and that it doesn't leak.

- ★ If it comes off, reinstall the hose joint.
- Run the fuel hose in accordance with the Cable, Wire, and Hose Routing section in the Appendix chapter.
- Install the fuel tank (see Fuel Tank Installation in the Fuel System (DFI) chapter).
- Start the engine and check the fuel hose for leaks.

Coolant Change

⚠ WARNING

Coolant can be extremely hot and cause severe burns, is toxic and very slippery. Do not remove the radiator cap or attempt to change the coolant when the engine is hot; allow it cool completely. Immediately wipe any spilled coolant from tires, frame, engine or other painted parts. Do not ingest coolant.

- Remove:
 - Left Side Cover (see Left Side Cover Removal in the Frame chapter)
 - Bolt [A]
 - Reserve Tank Cover [B]

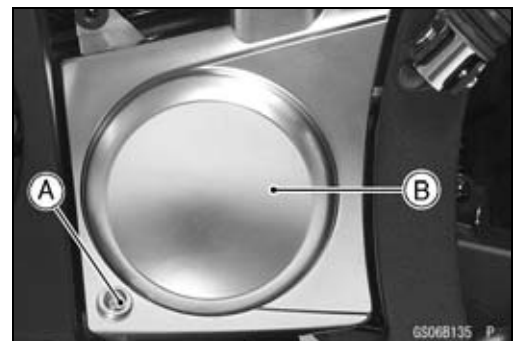

2-48 PERIODIC MAINTENANCE

Periodic Maintenance Procedures

- Remove:
 - Bolts [A]
 - Reserve Tank Cap [B]
- Turn over the reserve tank, and pour the coolant into the suitable container.

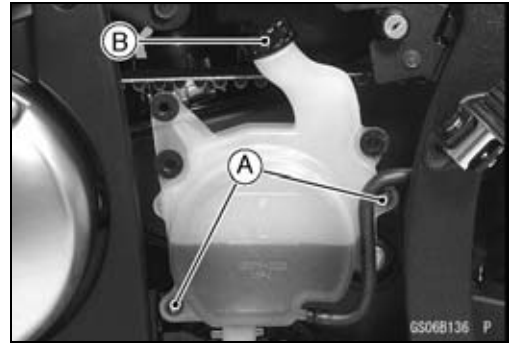

- Remove the fuel tank (see Fuel Tank Removal in the Fuel System (DFI) chapter).
- Remove the radiator cap [A] in two steps. First turn the cap counterclockwise to the first stop. Then push and turn it further in the same direction and remove the cap.



- Place a container under the coolant drain bolt [A], then remove the drain bolt.
- The coolant will drain from the radiator and engine.
- Install the reserve tank.



- When filling the coolant, choose a suitable mixture ratio by referring to the coolant manufacturer's directions.

NOTICE

Soft or distilled water must be used with the antifreeze in the cooling system. If hard water is used in the system, it causes scales accumulation in the water passages, and considerably reduces the efficiency of the cooling system.

Water and Coolant Mixture Ratio (Recommended)

| | | |
|----------------|---|-------------------|
| Soft Water | : | 50% |
| Coolant | : | 50% |
| Freezing Point | : | -35°C (-31°F) |
| Total Amount | : | 2.2 L (2.3 US qt) |

- Tighten:
 - Torque - Coolant Drain Bolt: 9.8 N·m (1.0 kgf·m, 87 in·lb)

Periodic Maintenance Procedures

- Fill the radiator up to the filler neck [A] with coolant.

NOTE

○ Pour in the coolant slowly so that it can expel the air from the engine and radiator.

- Check the cooling system for leaks.
- Tap the radiator hoses to force any air bubbles caught inside.
- Fill the radiator up to the filler neck with coolant.
- Install the radiator cap.

- Fill the reserve tank up to the "F" (full) level line [A] with coolant and install the cap.
- Install the fuel tank (see Fuel Tank Installation in the Fuel System (DFI) chapter).
- Start the engine, warm it up thoroughly until the radiator fan turns on and then stop the engine.
- Check the coolant level in the reserve tank after the engine cools down.
- ★ If the coolant level is lower than the "L" level line [B], add coolant to the "F" level line.

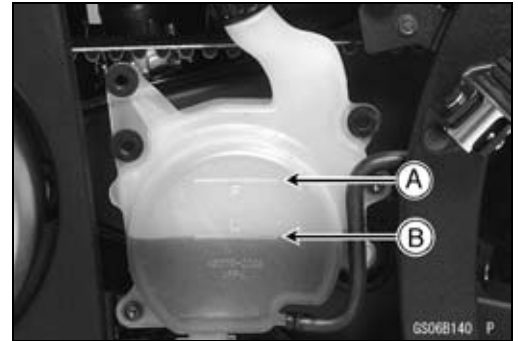

NOTICE

Do not add more coolant above the "F" level line.

Radiator Hose and O-ring Replacement

- Drain the coolant (see Coolant Change).
- Remove the thermostat bracket [A] (see Thermostat Removal in the Cooling System chapter).
- Loosen the radiator hose clamp screws and remove the hoses [B].
- Unscrew the bolts and remove the water hose fittings [C] and O-rings [D].
- Apply soap and water solution to the new O-ring and install the water hose fittings.
- Apply a non-permanent locking agent to the threads of the fitting bolts [E], and tighten them.

Torque - Water Hose Fitting Bolts: 9.8 N·m (1.0 kgf·m, 87 in·lb)

- Install the new hoses, and tighten the radiator hose clamp screws.

Torque - Radiator Hose Clamp Screws: 2.0 N·m (0.20 kgf·m, 18 in·lb)

Thermostat Housing Cover Bracket Bolt: 6.9 N·m (0.70 kgf·m, 61 in·lb)

- Fill the coolant (see Coolant Change).
- Check the cooling system for leaks.

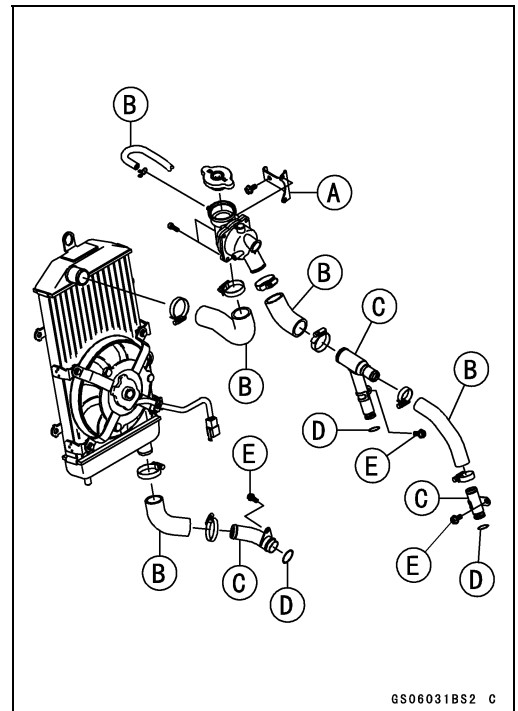

2-50 PERIODIC MAINTENANCE

Periodic Maintenance Procedures

Engine Oil Change

- Situate the motorcycle so that it is vertical after warming up the engine.
- Unscrew the oil filler cap [A].
- For VN900C7 ~ CA models, unscrew the cap using the following special tool.

Special Tool - Filler Cap Driver: 57001-1454



- Remove the engine oil drain plug [A] to drain the oil.
- The oil in the oil filter can be drained by removing the filter (see Oil Filter Replacement).
- ★ Replace the drain plug gasket with a new one.
- Tighten the drain plug.
Torque - Engine Oil Drain Plug: 20 N·m (2.0 kgf·m, 15 ft·lb)
- Pour in the specified type and amount of oil.

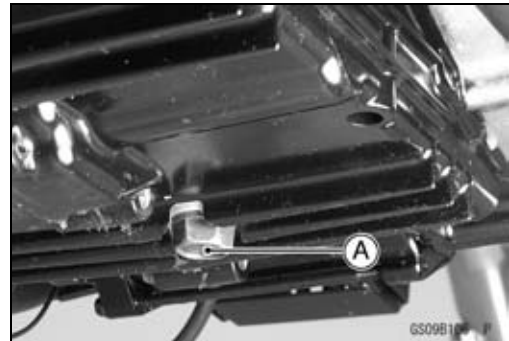

Recommended Engine Oil

- Type:** API SG, SH, SJ, SL or SM with JASO MA, MA1 or MA2
- Viscosity:** SAE 10W-40
- Amount:** 3.0 L (3.2 US qt) (when filter is not removed)
3.2 L (3.4 US qt) (when filter is removed)
3.7 L (3.9 US qt) (when engine is completely dry)

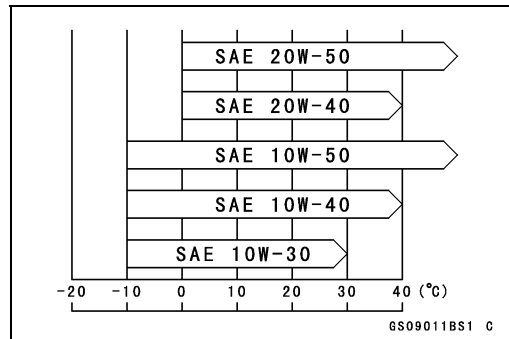

NOTE

- The oil viscosity may need to be changed to accommodate atmospheric conditions in your riding area.
- Do not add any chemical additive to the oil. Oils fulfilling the above requirements are fully formulated and provide adequate lubrication for the engine and the clutch.
- Although 10W-40 engine oil is the recommended oil for most conditions, the oil viscosity may need to be changed to accommodate atmospheric conditions in your riding area.
- Check the oil level (see Oil Level Inspection in the Engine Lubrication System chapter).

Periodic Maintenance Procedures

Oil Filter Replacement

- Drain the engine oil (see Engine Oil Change).
- Remove:
 - Regulator/Rectifier (see Regulator/Rectifier Removal in the Electrical System chapter)
 - Bolts [A]
 - Bracket [B]

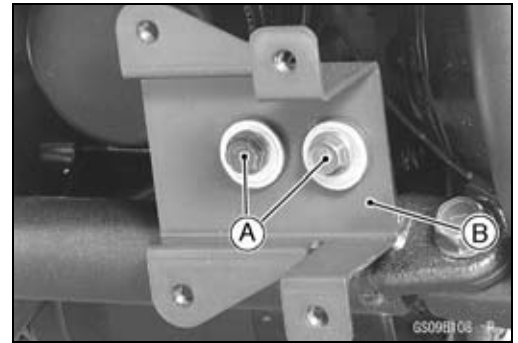

- Remove the oil filter [A] with the oil filter wrench [B] and discard the oil filter.

Special Tool - Oil Filter Wrench: 57001-1249

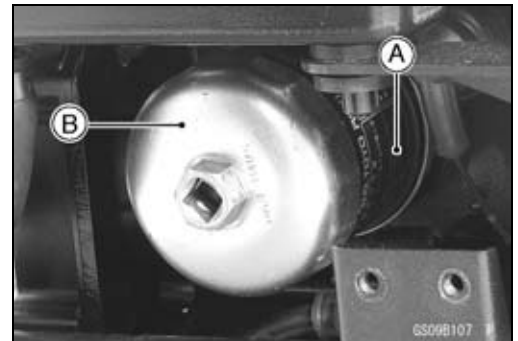

- Replace the oil filter with a new one.
 - Apply grease to the gasket [A] of the new filter before installation.
 - Tighten the filter with the oil filter wrench.
- Torque - Oil Filter: 18 N·m (1.8 kgf·m, 13 ft·lb)**
- Pour in the specified type and amount of oil (see Engine Oil Change).

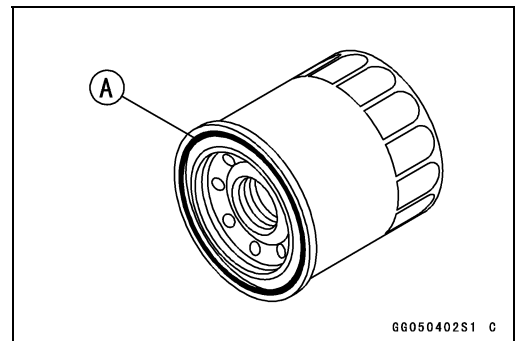

66050402S1 C

2-52 PERIODIC MAINTENANCE

Periodic Maintenance Procedures

Brake Hose Replacement

NOTICE

Brake fluid quickly ruins painted plastic surfaces; any spilled fluid should be completely washed away immediately.

- Remove the banjo bolts [A].
- When removing the brake hose [B], take care not to spill the brake fluid on the painted or plastic parts.
- When removing the brake hoses, temporarily secure the end of the brake hose to some high place to keep fluid loss to a minimum.
- Immediately wash away any brake fluid that spills.
- Install new brake hoses.
- There are washers [C] on each side of the brake hose fitting. Replace them with new ones when installing.
- Tighten the banjo bolts on the hose fittings.

Torque - Brake Hose Banjo Bolts: 25 N·m (2.5 kgf·m, 18 ft·lb)

- When installing the hoses, avoid sharp bending, kinking, flattening or twisting, and route the hoses according to Cable, Wire, and Hose Routing section in the Appendix chapter.
- Fill the brake line after installing the brake hose (see Brake Fluid Change).

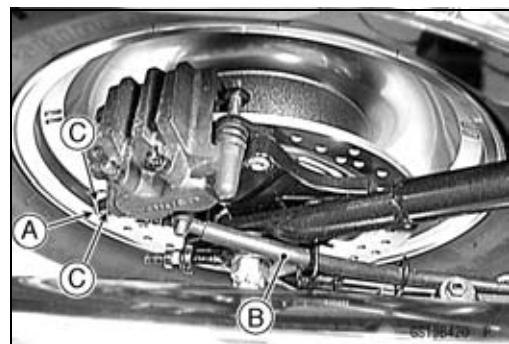
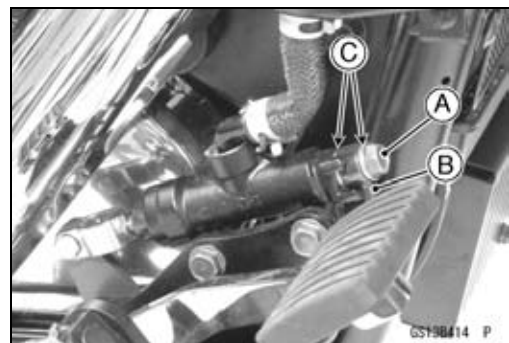
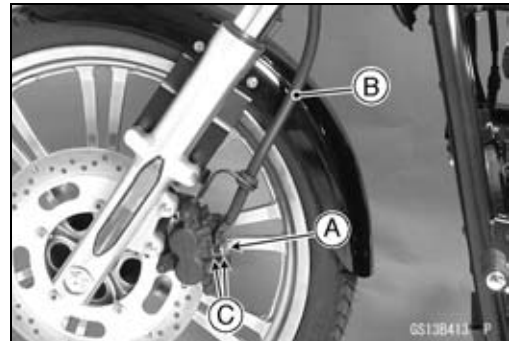
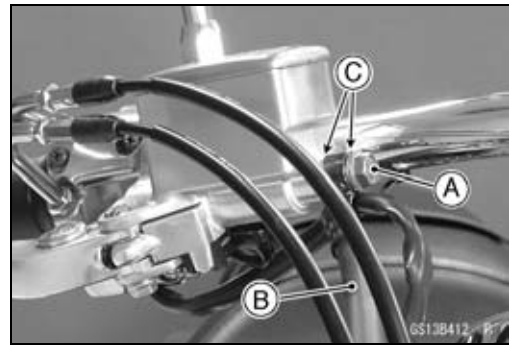

Brake Fluid Change

NOTE

- *The procedure to change the front brake fluid is as follows. Changing the rear brake fluid is the same as for the front brake.*

Periodic Maintenance Procedures

- Level the brake fluid reservoir.
- Remove:
 - Reservoir Cap [A]
 - Plate [B]
 - Diaphragm [C]

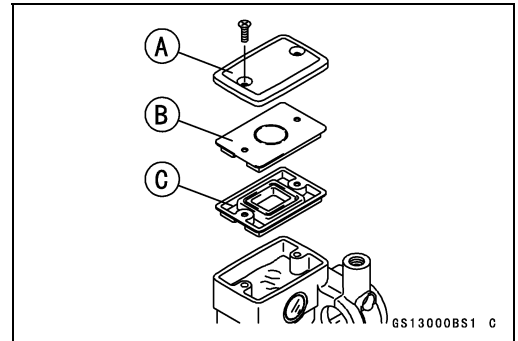

- Remove the rubber cap from the bleed valve [A] on the front caliper [B].
- Attach a clear plastic hose [C] to the bleed valve, and run the other end of the hose into a container.
- Fill the reservoir with fresh specified brake fluid.
- Temporarily install the reservoir cap.

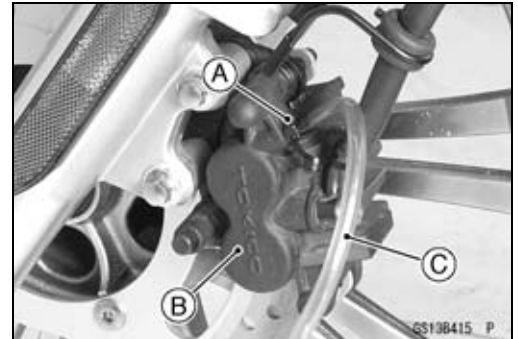

- Change the brake fluid.
- Repeat this operation until fresh brake fluid comes out from the plastic hose or the color of the fluid changes.
 1. Open the bleed valve [A].
 2. Apply the brake lever and hold it [B].
 3. Close the bleed valve [C].
 4. Release the brake lever [D].

NOTE

○ *The fluid level must be checked often during the changing operation and replenished with fresh brake fluid. If the fluid in the reservoir runs out any time during the changing operation, the brakes will need to be bled since air will have entered the brake line.*

- Remove the clear plastic hose.
- Install:
 - Diaphragm
 - Plate
 - Reservoir Cap
- Tighten:

Torque - Front Brake Reservoir Cap Screws: 1.5 N·m (0.15 kgf·m, 13 in·lb)

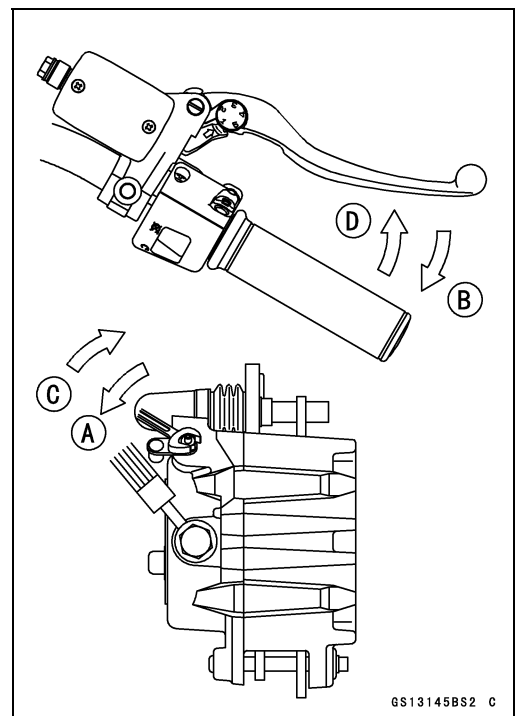

2-54 PERIODIC MAINTENANCE

Periodic Maintenance Procedures

- For the rear caliper [A], change the brake fluid for two bleed valves [B].

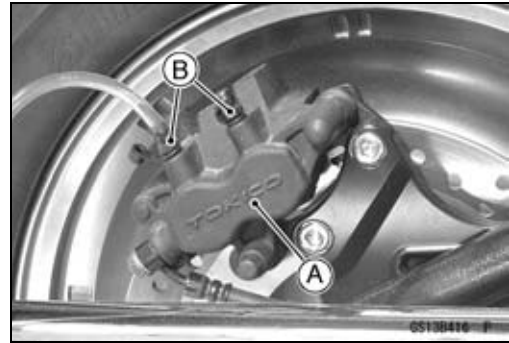

- Follow the procedure below to install the rear brake fluid reservoir cap correctly.
- First, tighten the rear brake fluid reservoir cap [B] clockwise [C] by hand until slight resistance is felt indicating that the cap is seated on the reservoir body, then tighten the cap an additional 1/6 turn [D] while holding the brake fluid reservoir body [A].

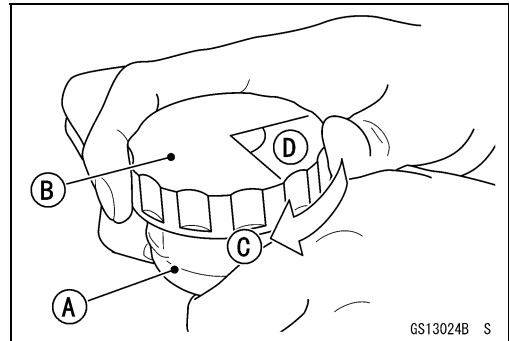

- Tighten the bleed valves, and install the rubber caps.
Torque - Bleed Valves: 7.8 N·m (0.80 kgf·m, 69 in·lb)
- After changing the fluid, check the brake for good braking power, no brake drag, and no fluid leakage.
- ★ If necessary, bleed the air from the lines (see Brake Line Bleeding in the Brakes chapter).

Master Cylinder Rubber Parts Replacement Front Master Cylinder Disassembly

- Remove the front master cylinder (see Front Master Cylinder Removal in the Brakes chapter).
- Remove the reservoir cap [A], plate [B] and diaphragm [C].
- Unscrew the locknut [D] and pivot bolt [E], and remove the brake lever.
- Pull the dust cover [F] out of place, and remove the circlip [G].
- Special Tool - Inside Circlip Pliers: 57001-143**
- Pull out the piston assy [H] and return spring [I].

NOTICE

Do not remove the secondary cup from the piston since removal will damage it.

- Replace:
 - Diaphragm
 - Dust Cover
 - Circlip
 - Piston Assy

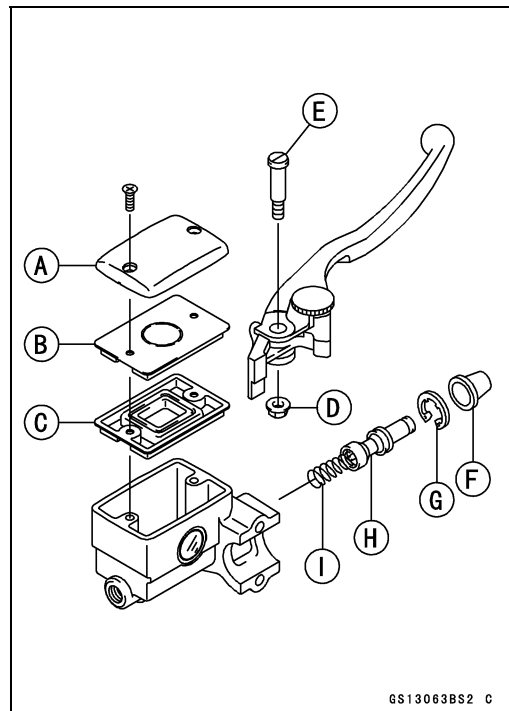

GS13063BS2 C

Periodic Maintenance Procedures

Rear Master Cylinder Disassembly

NOTE

○ Do not remove the push rod clevis [A] for master cylinder disassembly since removal requires brake pedal position adjustment.

- Remove the rear master cylinder (see Rear Master Cylinder Removal in the Brakes chapter).
- Remove the reservoir cap [B], plate [C] and diaphragm [D].
- Slide the dust cover [E] on the push rod out of place, and remove the circlip [F].

Special Tool - Inside Circlip Pliers: 57001-143

- Pull out the push rod with the piston stop.
- Take off the piston assy [G] (piston [H], primary cup [I], secondary cup [J]) and return spring [K].

NOTICE

Do not remove the secondary cup from the piston since removal will damage it.

- Replace:
 - Piston Assy
 - Dust Cover
 - Brake Hose [L]
 - Diaphragm
 - O-ring [M]
 - Circlips [F] [N]

Master Cylinder Assembly

- Before assembly, clean all parts including the master cylinder with brake fluid or alcohol.

NOTICE

Except for the disc pads and disc, use only disc brake fluid, isopropyl alcohol, or ethyl alcohol for cleaning brake parts. Do not use any other fluid for cleaning these parts. Gasoline, engine oil, or any other petroleum distillate will cause deterioration of the rubber parts. Oil spilled on any part will be difficult to wash off completely, and will eventually deteriorate the rubber used in the disc brake.

- Apply brake fluid to the new parts and to the inner wall of the cylinder.
- Take care not to scratch the piston or the inner wall of the cylinder.

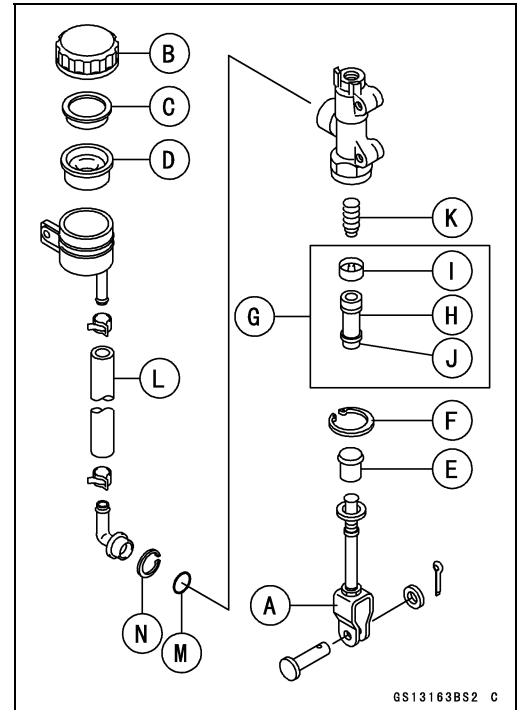

GS13163BS2 C

2-56 PERIODIC MAINTENANCE

Periodic Maintenance Procedures

- Tighten the brake lever pivot bolt and the locknut.
- Apply silicone grease.
 - Brake Lever Pivot Bolt
 - Brake Lever Pivot Contact
 - Push Rod Contact
 - Dust Cover
- Tighten:
 - Torque - Brake Lever Pivot Bolt: 1.0 N·m (0.10 kgf·m, 9 in·lb)**
 - Brake Lever Pivot Bolt Locknut: 5.9 N·m (0.60 kgf·m, 52 in·lb)**

Caliper Rubber Parts Replacement Front Caliper Disassembly

- Remove:
 - Front Caliper (see Front Caliper Removal in the Brakes chapter)
 - Brake Pads (see Front Brake Pad Removal in the Brakes chapter)
 - Pad Springs [A]
 - Caliper Holder [B]

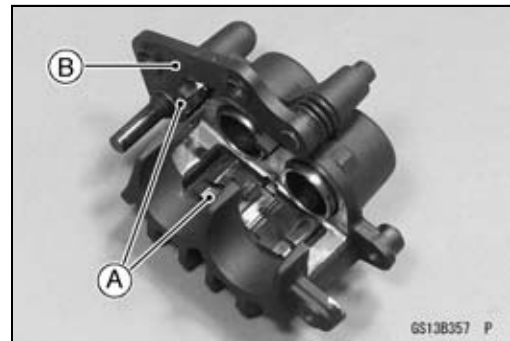

- Using compressed air, remove the pistons.

⚠ WARNING

The piston in the brake caliper can crush hands and fingers. Never place your hand or fingers in front of the piston.

- Insert a wooden board [A] 5 mm (0.2 in.) thick inside the caliper opening.
- Apply compressed air [B] to the banjo bolt hole to allow the pistons [C] to protrude and stop at the wooden board.
- Remove the wooden board and pull out the pistons by hand.

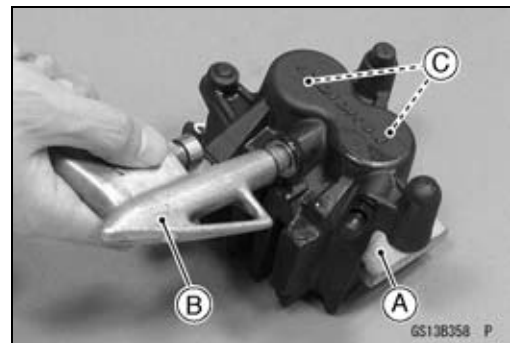

NOTE

○ If compressed air is not available, with the brake hose still attached, apply the brake lever to remove the pistons. The remaining process is as described above.

- Remove:
 - Dust Seals [A]
 - Fluid Seals [B]
 - Friction Boot [C]
 - Dust Boot [D]
 - Bleed Valve [E]
 - Rubber Cap [F]

NOTICE

Immediately wash away any brake fluid that spills.

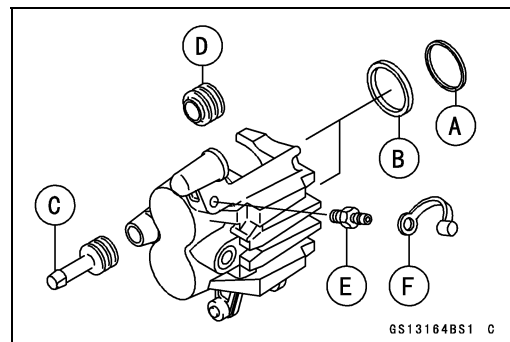

Periodic Maintenance Procedures

Front Caliper Assembly

- Clean the caliper parts except for the pads.

NOTICE

For cleaning the parts, use only disc brake fluid, isopropyl alcohol, or ethyl alcohol.

- Install the bleed valve [A] and the rubber cap [B].
Torque - Bleed Valve: 7.8 N·m (0.80 kgf·m, 69 in·lb)

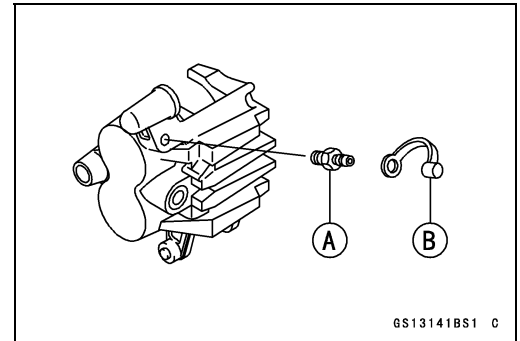

GS13141BS1 C

- Replace the fluid seals [A] with new ones.
- Apply brake fluid to the fluid seals, and install them into the cylinders by hand.
- Replace the dust seals [B] with new ones if they are damaged.
- Apply brake fluid to the dust seals, and install them into the cylinders by hand.

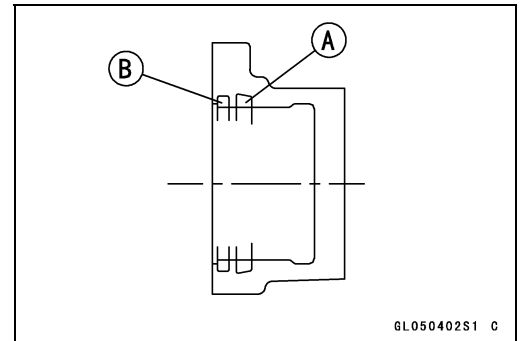

6L050402S1 C

- Apply brake fluid to the outside of the pistons, and push the pistons [A] into each cylinder by hand.
- Check the friction boot [B] and dust boot [C] and replace them with new ones if they are damaged.
- Apply a thin coat of PBC (Poly Butyl Caprysil) grease to the caliper holder shafts [D] and the holder holes (PBC is a special high-temperature, water-resistance grease).

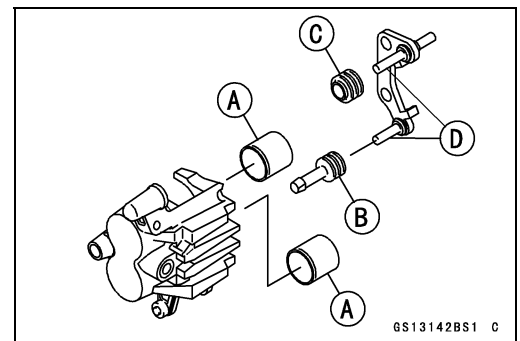

GS13142BS1 C

- Install the pad springs [A].
- Install the pads (see Front Brake Pad Installation in the Brakes chapter).
- Wipe up any spilled brake fluid on the caliper with wet cloth.

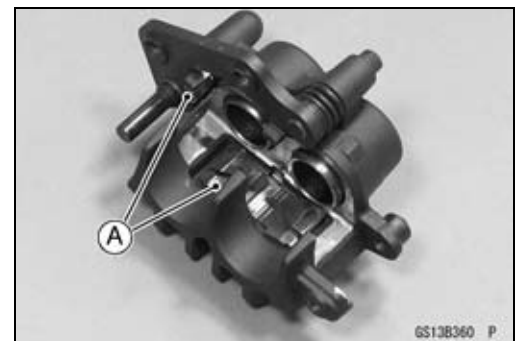

GS138360 P

Rear Caliper Disassembly

- Remove:
 - Rear Caliper (see Rear Caliper Removal in the Brakes chapter)
 - Brake Pads (see Rear Brake Pad Removal in the Brakes chapter)
 - Pad Springs [A]
 - Caliper Holder [B]

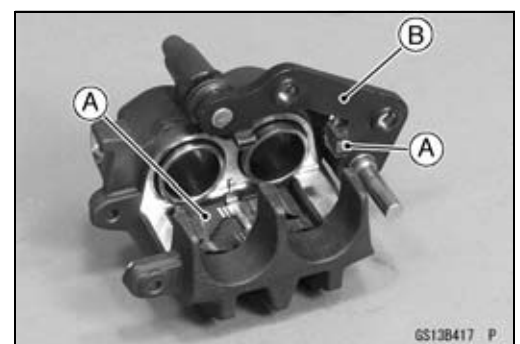

GS138417 P

2-58 PERIODIC MAINTENANCE

Periodic Maintenance Procedures

- Using compressed air, remove the pistons.

⚠ WARNING

The piston in the brake caliper can crush hands and fingers. Never place your hand or fingers in front of the piston.

- Insert a wooden board [A] 5 mm (0.2 in.) thick inside the caliper opening.
- Apply compressed air [B] to the banjo bolt hole to allow the pistons [C] to protrude and stop at the wooden board.
- Remove the wooden board and pull out the pistons by hand.

NOTE

○ If compressed air is not available, with the brake hose still attached, apply the brake pedal to remove the pistons. The remaining process is as described above.

- Remove:
 - Dust Seals [A]
 - Fluid Seals [B]
 - Friction Boot [C]
 - Dust Boot [D]
 - Bleed Valves [E]
 - Rubber Caps [F]

NOTICE

Immediately wash away any brake fluid that spills.

Rear Caliper Assembly

- Clean the caliper parts except for the pads.

NOTICE

For cleaning the parts, use only disc brake fluid, isopropyl alcohol, or ethyl alcohol.

- Install the bleed valves [A] and the rubber caps [B].
Torque - Bleed Valves: 7.8 N·m (0.80 kgf·m, 69 in·lb)

- Replace the fluid seals [A] with new ones.
 - Apply brake fluid to the fluid seals, and install them into the cylinders by hand.
- Replace the dust seals [B] with new ones if they are damaged.
 - Apply brake fluid to the dust seals, and install them into the cylinders by hand.

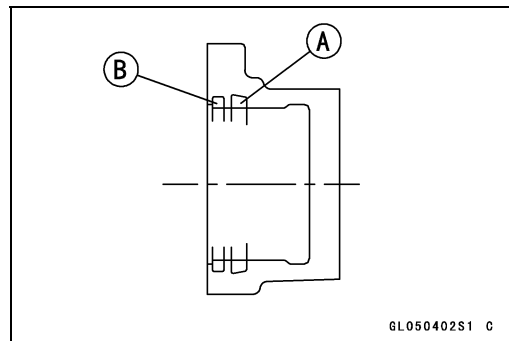
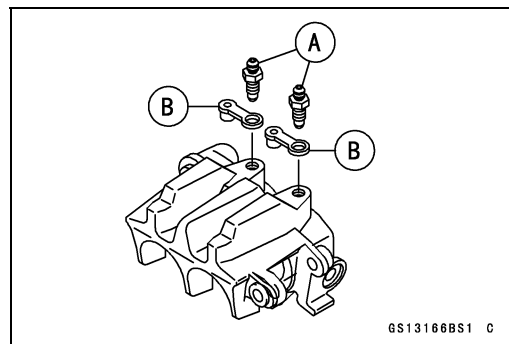
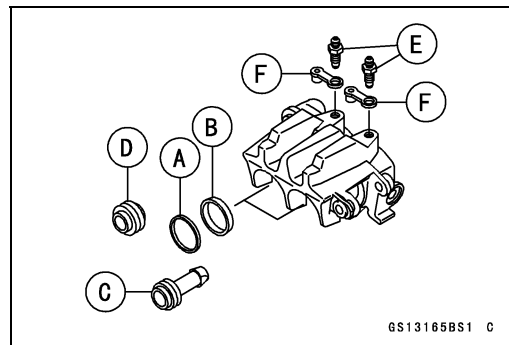
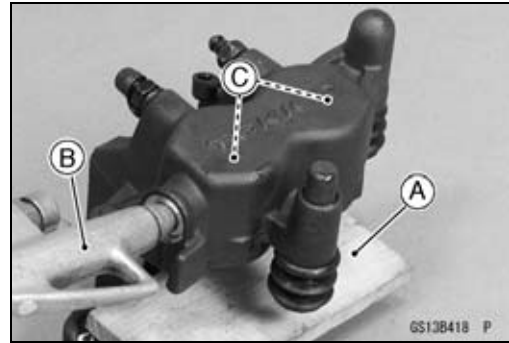

Periodic Maintenance Procedures

- Apply brake fluid to the outside of the pistons and push the pistons [A] into each cylinder by hand.
- Check the friction boot [B] and dust boot [C] and replace them with new ones if they are damaged.
- Apply a thin coat of PBC (Poly Butyl Cuprysil) grease to the caliper holder shafts [D] and the holder holes (PBC is a special high-temperature, water-resistance grease).

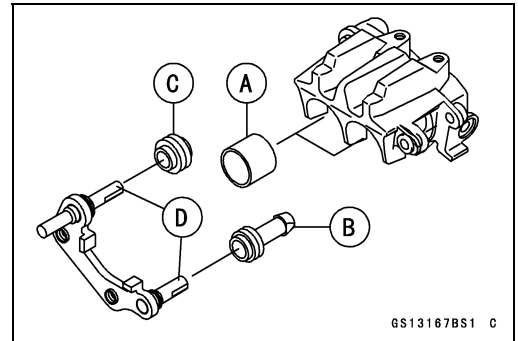

- Install the pad springs [A].
- Install the pads (see Rear Brake Pad Installation in the Brakes chapter).
- Wipe up any spilled brake fluid on the caliper with wet cloth.

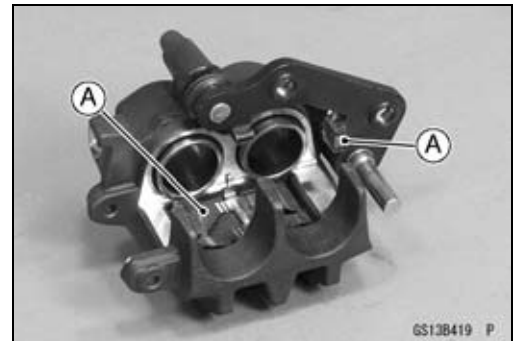

Spark Plug Replacement

- Remove:
 - Fuel Tank (see Fuel Tank Removal in the Fuel System (DFI) chapter)
 - Spark Plug Caps [A]
- Remove the spark plug using the 16 mm (0.63 in.) plug wrench vertically.

Special Tool - Spark Plug Wrench, Hex 16: 57001-1262

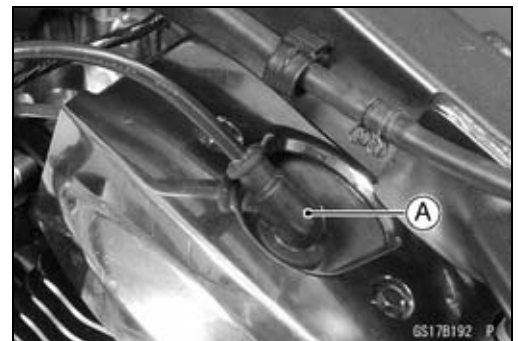

- Replace the spark plug with a new one.

Standard Spark Plug
Type: NGK CPR7EA-9

- Insert new spark plug in the plug hole, and finger-tighten it first.
- Using the plug wrench [A] vertically, tighten the plug.



NOTICE

The insulator of the spark plug may break if when the wrench is inclined during tightening.

Special Tool - Spark Plug Wrench, Hex16: 57001-1262

Torque - Spark Plugs: 18 N·m (1.8 kgf·m, 13 ft·lb)

- Install the spark plug caps securely.
- Be sure the spark plug caps are installed by pulling up it lightly.
- Install the fuel tank (see Fuel Tank Installation in the Fuel System (DFI) chapter).

Fuel System (DFI)

Table of Contents

| | |
|--|------|
| Exploded View..... | 3-4 |
| Specifications | 3-8 |
| Special Tools and Sealant | 3-10 |
| DFI Parts Location..... | 3-11 |
| DFI System..... | 3-14 |
| DFI Servicing Precautions..... | 3-26 |
| DFI Servicing Precautions | 3-26 |
| Troubleshooting the DFI System | 3-28 |
| Outline | 3-28 |
| Outline..... | 3-28 |
| Inquiries to Rider..... | 3-32 |
| Inquiries to Rider..... | 3-32 |
| DFI System Troubleshooting Guide | 3-35 |
| Self-Diagnosis | 3-43 |
| Self-diagnosis Outline..... | 3-43 |
| Self-diagnosis Outline | 3-43 |
| Self-diagnosis Procedures..... | 3-43 |
| Self-diagnosis Procedures | 3-43 |
| Service Code Clearing Procedures | 3-44 |
| Service Code Clearing Procedures..... | 3-44 |
| Service Code Reading..... | 3-46 |
| Service Code Reading | 3-46 |
| Service Code Erasing | 3-46 |
| Service Code Erasing | 3-46 |
| Service Code Table..... | 3-47 |
| Service Code Table..... | 3-47 |
| Backups..... | 3-49 |
| Backups | 3-49 |
| Main Throttle Sensor (Service Code 11) | 3-51 |
| Main Throttle Sensor Removal/Adjustment | 3-51 |
| Main Throttle Sensor Input Voltage Inspection | 3-51 |
| Main Throttle Sensor Output Voltage Inspection | 3-52 |
| Main Throttle Sensor Resistance Inspection | 3-53 |
| Inlet Air Pressure Sensor (Service Code 12)..... | 3-55 |
| Inlet Air Pressure Sensor Removal..... | 3-55 |
| Inlet Air Pressure Sensor Installation..... | 3-55 |
| Inlet Air Pressure Sensor Input Voltage Inspection..... | 3-55 |
| Inlet Air Pressure Sensor Output Voltage Inspection..... | 3-56 |
| Inlet Air Temperature Sensor (Service Code 13)..... | 3-60 |
| Inlet Air Temperature Sensor Removal/Installation | 3-60 |
| Inlet Air Temperature Sensor Output Voltage Inspection | 3-60 |
| Inlet Air Temperature Sensor Resistance Inspection | 3-61 |
| Water Temperature Sensor (Service Code 14) | 3-63 |
| Water Temperature Sensor Removal/Installation | 3-63 |
| Water Temperature Sensor Output Voltage Inspection..... | 3-63 |
| Water Temperature Sensor Resistance Inspection..... | 3-63 |
| Crankshaft Sensor (Service Code 21)..... | 3-65 |
| Crankshaft Sensor Removal/Installation..... | 3-65 |
| Crankshaft Sensor Inspection..... | 3-65 |
| Speed Sensor (Service Code 24, 25)..... | 3-67 |

3-2 FUEL SYSTEM (DFI)

| | |
|---|-------|
| Speed Sensor Removal | 3-67 |
| Speed Sensor Installation | 3-67 |
| Speed Sensor Inspection..... | 3-67 |
| Speed Sensor Input Voltage Inspection..... | 3-67 |
| Speed Sensor Output Voltage Inspection | 3-68 |
| Vehicle-down Sensor (Service Code 31)..... | 3-70 |
| Vehicle-down Sensor Removal | 3-70 |
| Vehicle-down Sensor Installation | 3-70 |
| Vehicle-down Sensor Inspection..... | 3-70 |
| Subthrottle Sensor (Service Code 32)..... | 3-73 |
| Subthrottle Sensor Removal/Adjustment..... | 3-73 |
| Subthrottle Sensor Input Voltage Inspection..... | 3-73 |
| Subthrottle Sensor Output Voltage Inspection..... | 3-74 |
| Subthrottle Sensor Resistance Inspection | 3-75 |
| Oxygen Sensor-not activated #1, #2 (Service Code 33, 83) (Oxygen Sensor Equipped Models)..... | 3-77 |
| Oxygen Sensor Removal/Installation..... | 3-77 |
| Oxygen Sensor Inspection..... | 3-77 |
| Ignition Coils #1, #2 (Service Code 51, 52)..... | 3-80 |
| Ignition Coil Removal/Installation..... | 3-80 |
| Ignition Coil Input Voltage Inspection..... | 3-80 |
| Radiator Fan Relay (Service Code 56)..... | 3-82 |
| Radiator Fan Relay Removal/Installation..... | 3-82 |
| Radiator Fan Relay Inspection..... | 3-82 |
| Subthrottle Valve Actuator (Service Code 62)..... | 3-85 |
| Subthrottle Valve Actuator Removal | 3-85 |
| Subthrottle Valve Actuator Inspection | 3-85 |
| Subthrottle Valve Actuator Resistance Inspection | 3-85 |
| Subthrottle Valve Actuator Input Voltage Inspection | 3-86 |
| Air Switching Valve (Service Code 64)..... | 3-88 |
| Air Switching Valve Removal/Installation | 3-88 |
| Air Switching Valve Inspection | 3-88 |
| Oxygen Sensor Heaters #1, #2 (Service Code 67) (Oxygen Sensor Equipped Models) | 3-92 |
| Oxygen Sensor Heater Removal/Installation | 3-92 |
| Oxygen Sensor Heater Inspection | 3-92 |
| Oxygen Sensors-Incorrect Output Voltage #1, #2 (Service Code 94, 95) (Oxygen Sensor Equipped Models)..... | 3-95 |
| Oxygen Sensor Removal/Installation..... | 3-95 |
| Oxygen Sensor Inspection..... | 3-95 |
| FI Indicator Light (LED) | 3-98 |
| Light (LED) Inspection | 3-99 |
| ECU | 3-102 |
| ECU Removal | 3-102 |
| ECU Installation | 3-102 |
| ECU Power Supply Inspection..... | 3-102 |
| Fuel Line..... | 3-104 |
| Fuel Pressure Inspection | 3-104 |
| Fuel Flow Rate Inspection | 3-105 |
| Fuel Pump | 3-107 |
| Fuel Pump Removal | 3-107 |
| Fuel Pump Installation | 3-107 |
| Pump Screen, Fuel Filter Cleaning | 3-108 |
| Fuel Pump Operation Inspection | 3-108 |
| Fuel Pump Operating Voltage Inspection | 3-109 |
| Fuel Pump Power Source Voltage Inspection..... | 3-110 |
| Fuel Injectors..... | 3-115 |
| Fuel Injector Removal..... | 3-115 |

| | |
|---|-------|
| Fuel Injector Installation | 3-116 |
| Fuel Injector Fuel Line Inspection | 3-117 |
| Fuel Injector Audible Inspection | 3-118 |
| Fuel Injector Power Source Voltage Inspection | 3-118 |
| Fuel Injector Output Voltage Inspection | 3-119 |
| Fuel Injector Signal Test | 3-120 |
| Fuel Injector Resistance Inspection | 3-121 |
| Fuel Injector Unit Test | 3-121 |
| Throttle Grip and Cables | 3-126 |
| Throttle Grip Free Play Inspection | 3-126 |
| Throttle Grip Free Play Adjustment | 3-126 |
| Cable Removal/Installation | 3-126 |
| Cable Lubrication and Inspection | 3-126 |
| Throttle Body Assy | 3-127 |
| Idle Speed Inspection | 3-127 |
| Idle Speed Adjustment | 3-127 |
| Throttle Bore Cleaning | 3-127 |
| High Altitude Performance Adjustment | 3-127 |
| Throttle Body Assy and Inlet Manifold Removal | 3-127 |
| Throttle Body Assy and Inlet Manifold Installation | 3-129 |
| Air Cleaner | 3-132 |
| Air Cleaner Element Removal/Installation | 3-132 |
| Air Cleaner Housing Removal | 3-132 |
| Air Cleaner Housing Installation | 3-132 |
| Fuel Tank | 3-134 |
| Fuel Tank Removal | 3-134 |
| Fuel Tank Installation | 3-137 |
| Fuel Tank and Cap Inspection | 3-139 |
| Fuel Tank Cleaning | 3-139 |
| Breather Check Valve Inspection | 3-139 |
| Evaporative Emission Control System (CAL, TH and SEA-B1 Models) | 3-140 |
| Parts Removal/Installation | 3-140 |
| Hose Inspection | 3-140 |
| Canister Inspection | 3-140 |
| Separator Inspection | 3-140 |
| Separator Operation Test | 3-141 |

3-4 FUEL SYSTEM (DFI)

Exploded View

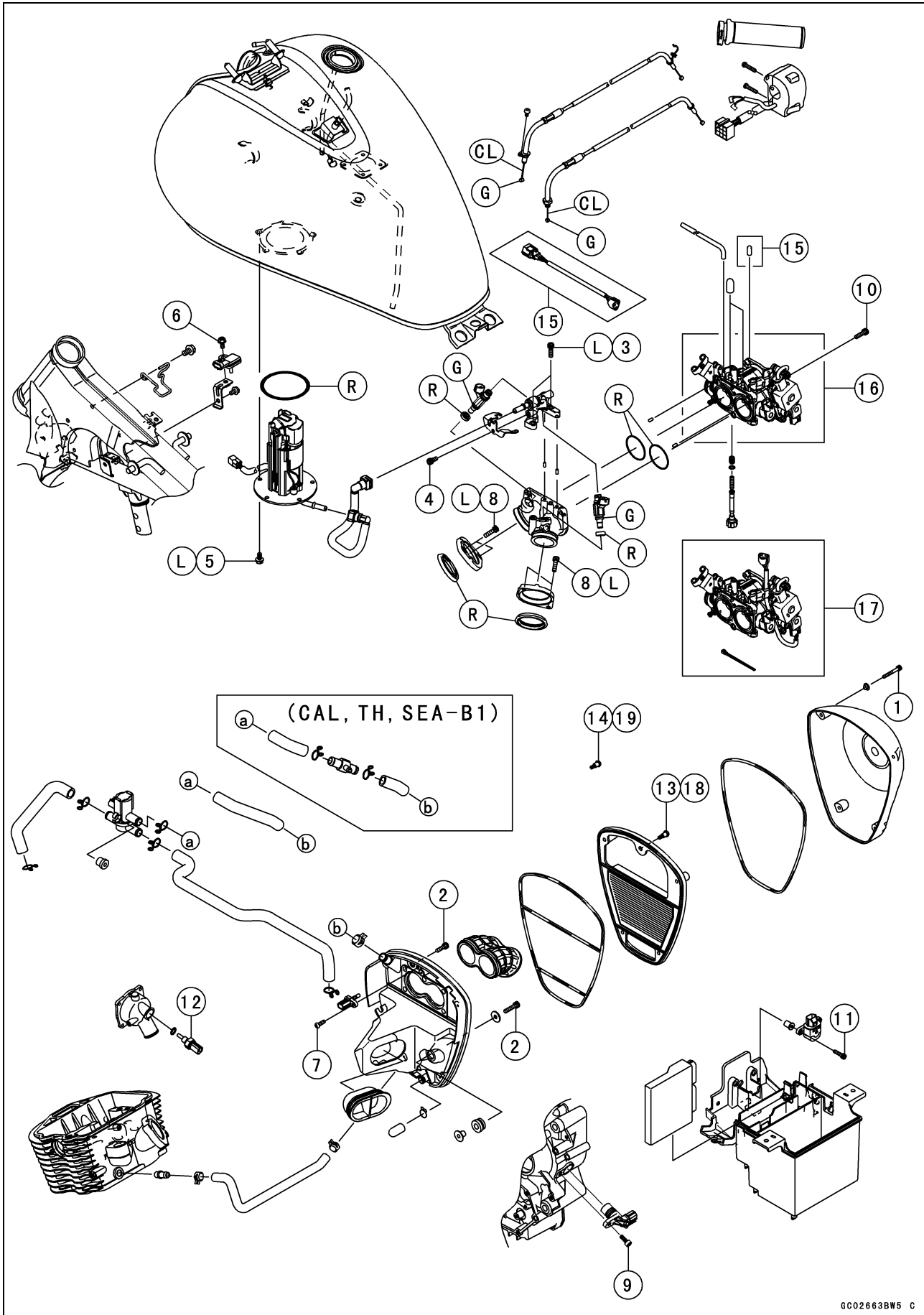

6C02663BW5 C

Exploded View

| No. | Fastener | Torque | | | Remarks |
|-----|------------------------------------|--------|-------|-----------|---------|
| | | N·m | kgf·m | ft·lb | |
| 1 | Air Cleaner Cover Bolts | 4.9 | 0.50 | 43 in·lb | |
| 2 | Air Cleaner Housing Bolts | 9.8 | 1.0 | 87 in·lb | |
| 3 | Delivery Joint Bolts | 9.8 | 1.0 | 87 in·lb | L |
| 4 | Delivery Joint Bracket Bolt | 9.8 | 1.0 | 87 in·lb | |
| 5 | Fuel Pump Bolts | 9.8 | 1.0 | 87 in·lb | L |
| 6 | Inlet Air Pressure Sensor Bolt | 6.9 | 0.70 | 61 in·lb | |
| 7 | Inlet Air Temperature Sensor Screw | 1.2 | 0.12 | 11 in·lb | |
| 8 | Inlet Manifold Bolts | 9.8 | 1.0 | 87 in·lb | L |
| 9 | Speed Sensor Mounting Bolt | 9.8 | 1.0 | 87 in·lb | |
| 10 | Throttle Body Assy Holder Bolts | 9.8 | 1.0 | 87 in·lb | |
| 11 | Vehicle-down Sensor Bolts | 1.0 | 0.10 | 8.9 in·lb | |
| 12 | Water Temperature Sensor | 12 | 1.2 | 106 in·lb | |
| 13 | Air Cleaner Element Screw | 2.9 | 0.30 | 26 in·lb | |
| 14 | Air Cleaner Element Bolt | 2.9 | 0.30 | 26 in·lb | |

15. VN900C7 Models

16. VN900C7 Models

17. VN900C8 ~ Models

18. VN900C7 ~ C8 Models

19. VN900C9 ~ Models

CL: Apply cable lubricant.

G: Apply grease.

L: Apply a non-permanent locking agent.

R: Replacement Parts

3-6 FUEL SYSTEM (DFI)

Exploded View

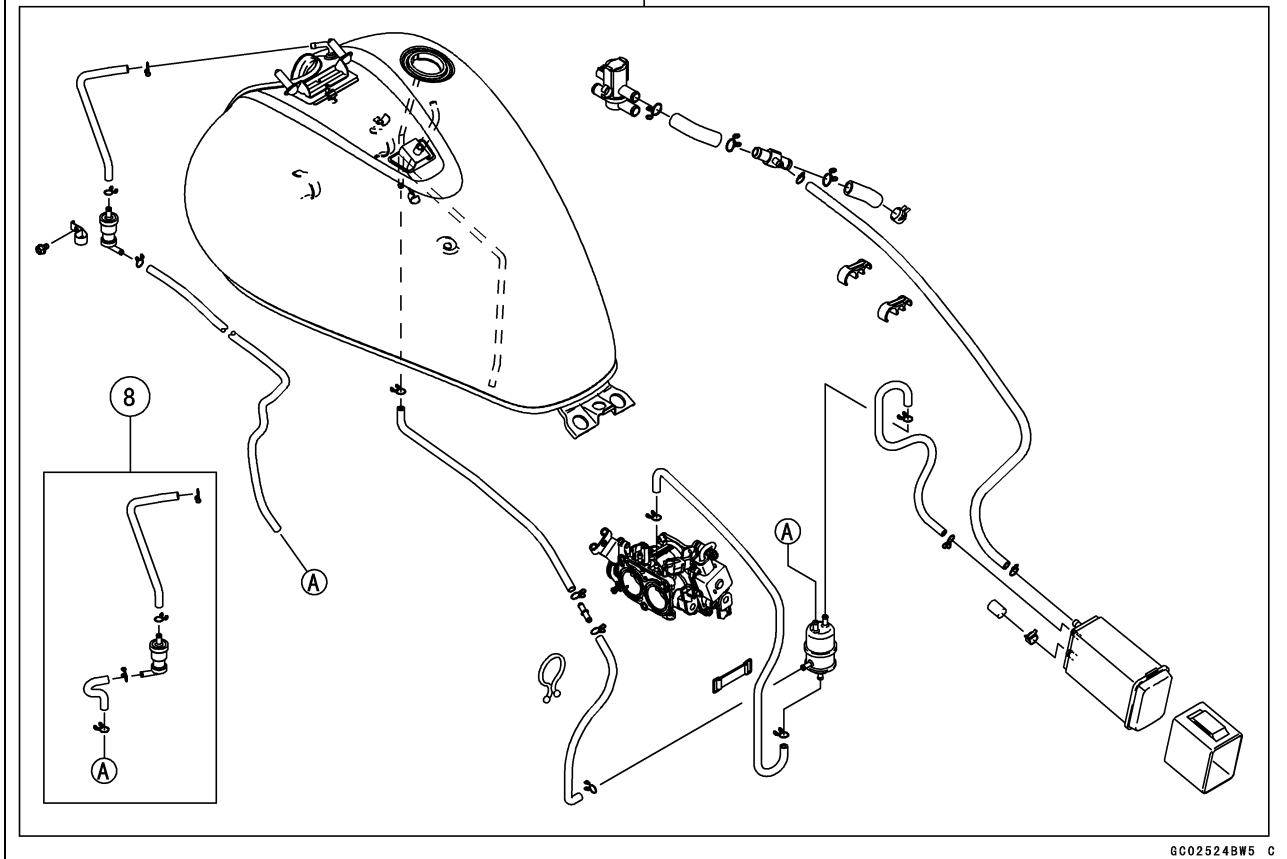
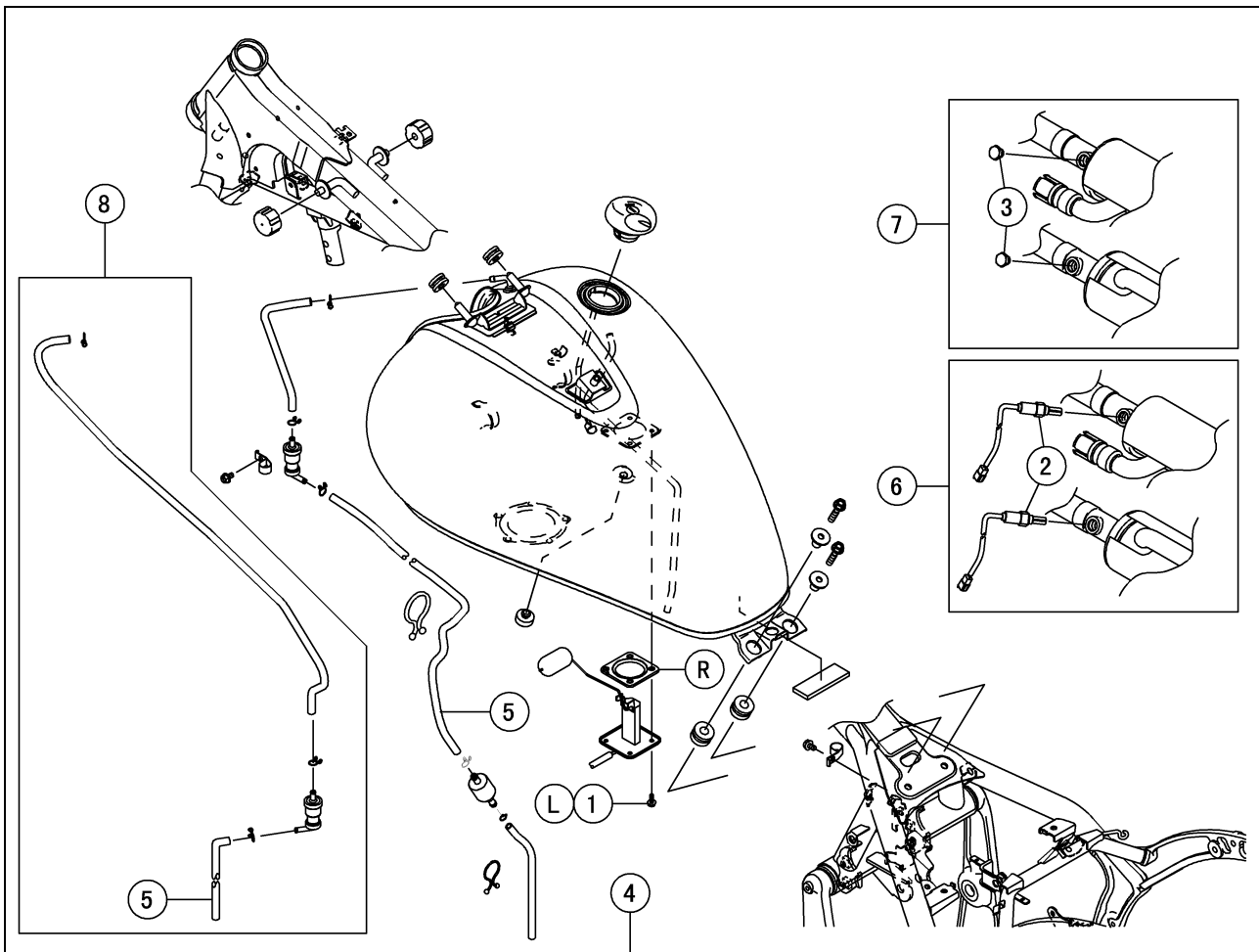

GC02524BW5 C

Exploded View

| No. | Fastener | Torque | | | Remarks |
|-----|----------------------------------|--------|-------|----------|---------|
| | | N·m | kgf·m | ft·lb | |
| 1 | Fuel Level Sensor Mounting Bolts | 6.9 | 0.70 | 61 in·lb | L |
| 2 | Oxygen Sensors | 25 | 2.5 | 18 | |
| 3 | Oxygen Sensor Plugs | 25 | 2.5 | 18 | |

4. CAL, TH and SEA-B1 Models

5. Breather Hose (Other than CAL, TH and SEA-B1 Models)

6. Oxygen Sensor Equipped Models

7. AU Models (VN900C9 ~)

8. VN900C7 ~ CB

L: Apply a non-permanent locking agent.

R: Replacement Parts

3-8 FUEL SYSTEM (DFI)

Specifications

| Item | Standard |
|-------------------------------------|--|
| DFI System | |
| Idle Speed | 1 000 ±50 r/min (rpm) |
| Throttle Body Assy: | |
| Throttle Valve | Dual throttle valve |
| Bore | φ34 mm (1.34 in.) |
| ECU (Electronic Control Unit): | |
| Make | Denso |
| Type | Digital memory type, with built in IC igniter, sealed with resin |
| Usable Engine Speed | 100 ~ 7 630 r/min (rpm) |
| Fuel Pressure (High Pressure Line): | |
| With Engine Idling | 294 kPa (3.0 kgf/cm ² , 43 psi) with fuel pump running |
| Fuel Pump: | |
| Type | In-tank friction pump |
| Discharge | 50 mL (1.7 US oz.) or more for 3 seconds |
| Fuel Injectors: | |
| Type | INP-287 |
| Nozzle Type | Fine atomizing type with 12 holes |
| Resistance | 11.7 ~ 12.3 Ω at 20°C (68°F) |
| Main Throttle Sensor: | Non-adjustable and non-removable |
| Input Voltage | DC 4.75 ~ 5.25 V between BL and BR/BK leads |
| Output Voltage | DC 1.05 ~ 4.26 V between Y/W and BR/BK leads (at idle throttle opening to full throttle opening) |
| Resistance | 4 ~ 6 kΩ |
| Inlet Air Pressure Sensor: | |
| Input Voltage | DC 4.75 ~ 5.25 V between BL and BR/BK leads |
| Output Voltage | DC 3.80 ~ 4.20 V between Y/BL and BR/BK leads (at standard atmospheric pressure) |
| Inlet Air Temperature Sensor: | |
| Resistance | 5.4 ~ 6.6 kΩ at 0°C (32°F) 0.29 ~ 0.39 kΩ at 80°C (176°F) |
| Output Voltage at ECU | About 2.25 ~ 2.50 V at 20°C (68°F) |
| Water Temperature Sensor: | |
| Resistance | see Electrical System chapter |
| Output Voltage at ECU | About 2.80 ~ 2.97 V at 20°C (68°F) |
| Speed Sensor: | |
| Input Voltage at Sensor | DC 4.75 ~ 5.25 V at Ignition Switch ON |
| Output Voltage at Sensor | About DC 0.05 ~ 0.09 V or DC 4.5 ~ 4.9 V at Ignition Switch ON and 0 km/h |
| Vehicle-down Sensor: | |
| Detection Method | Magnetic flux detection method |
| Detection Angle | More than 45° ±5° for each bank |
| Output Voltage | with sensor arrow mark pointed up: 3.55 ~ 4.45 V with sensor tilted 40 ~ 50° or more: 0.65 ~ 1.35 V |

Specifications

| Item | Standard |
|--|--|
| Subthrottle Sensor: Input Voltage VN900C7 VN900C8 ~ Output Voltage VN900C7 VN900C8 ~ Resistance Subthrottle Valve Actuator: Resistance Input Voltage Oxygen Sensors (Oxygen Sensor Equipped Models): Output Voltage (Rich) Output Voltage (Lean) Heater Resistance | Non-adjustable and non-removable DC 4.75 ~ 5.25 V between BL and BR/BK leads DC 4.75 ~ 5.25 V between BL and BK leads DC 0.93 ~ 4.59 V between BL/W and BR/BK leads (at idle throttle opening to full throttle opening) DC 0.93 ~ 4.59 V between Y and BK leads (at idle throttle opening to full throttle opening) 4 ~ 6 kΩ About 5.2 ~ 7.8 Ω About DC 8.9 ~ 10.9 V 0.45 ~ 2.5 V 0.05 ~ 0.45 V About 8 Ω at 20°C (68°F) |
| Throttle Grip Free Play | 2 ~ 3 mm (0.08 ~ 0.12 in.) |
| Air Cleaner Element | Viscous paper element |

3-10 FUEL SYSTEM (DFI)

Special Tools and Sealant

Oil Pressure Gauge, 5 kgf/cm²:

57001-125

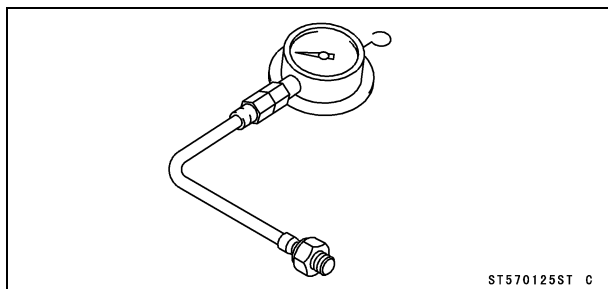

ST570125ST C

Fuel Pressure Gauge Adapter:

57001-1593

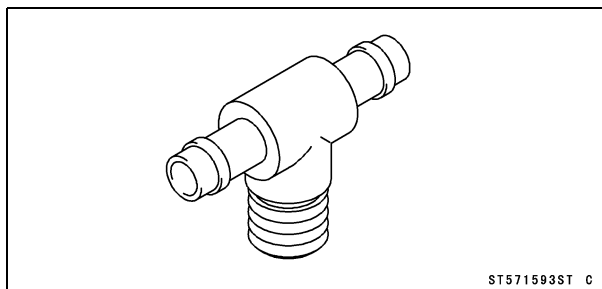

ST571593ST C

Fork Oil Level Gauge:

57001-1290

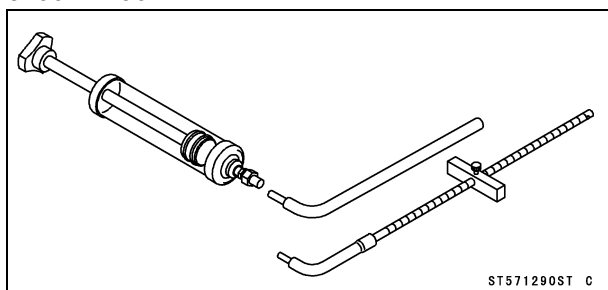

ST571290ST C

Fuel Hose:

57001-1607

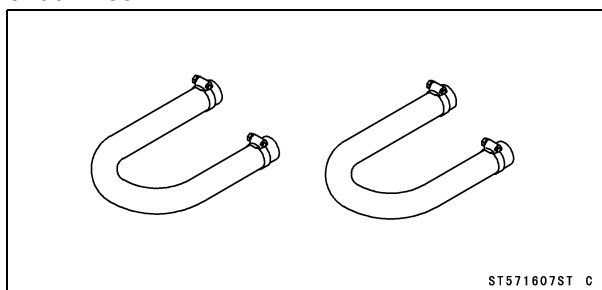

ST571607ST C

Peak Voltage Adapter:

57001-1415

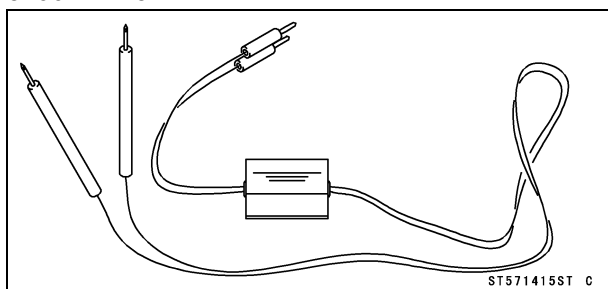

ST571415ST C

Speed Sensor Measuring Adapter:

57001-1667

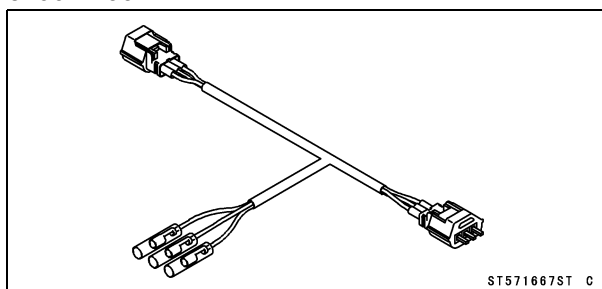

ST571667ST C

Filler Cap Driver:

57001-1454

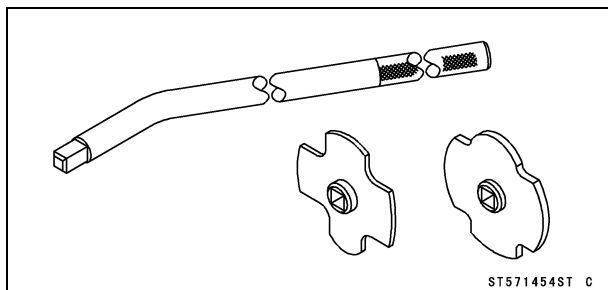

ST571454ST C

Liquid Gasket, TB1211:

56019-120

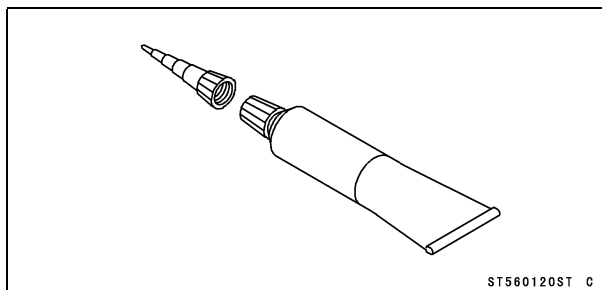

ST560120ST C

Needle Adapter Set:

57001-1457

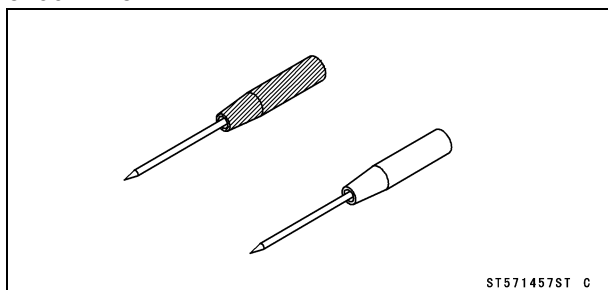

ST571457ST C

DFI Parts Location

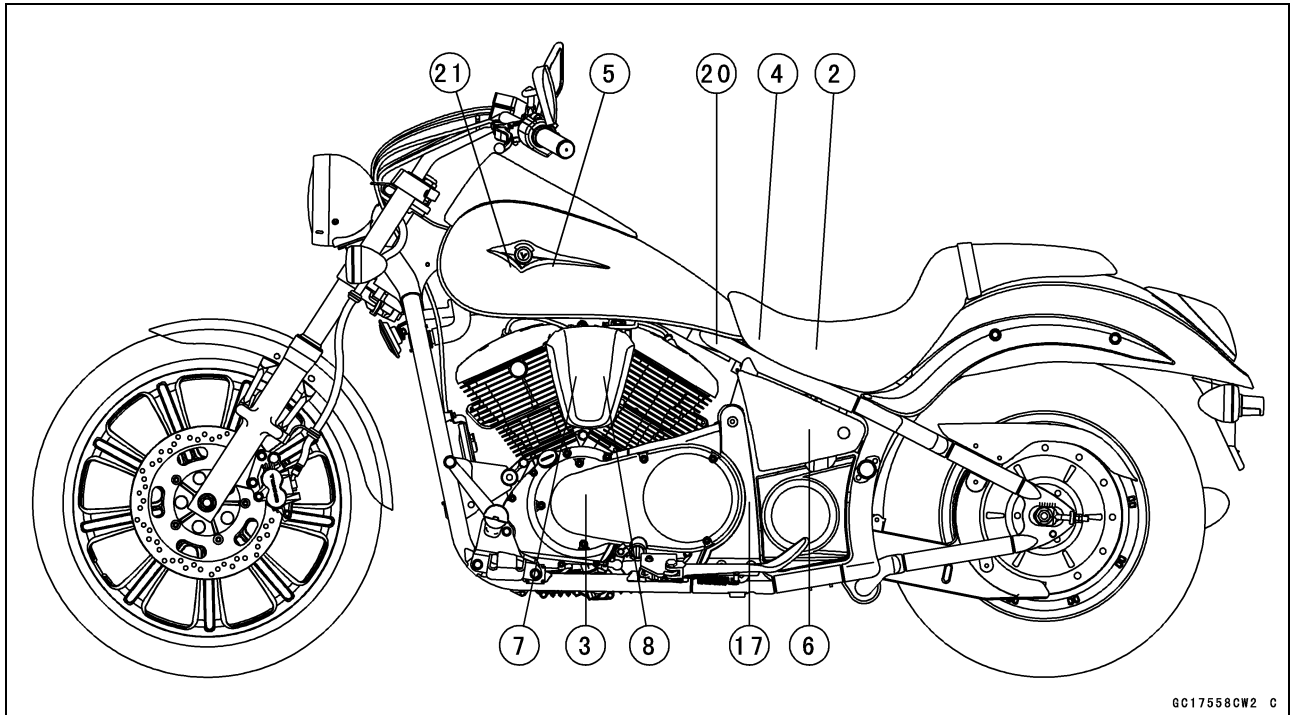

GC17559CW2 C

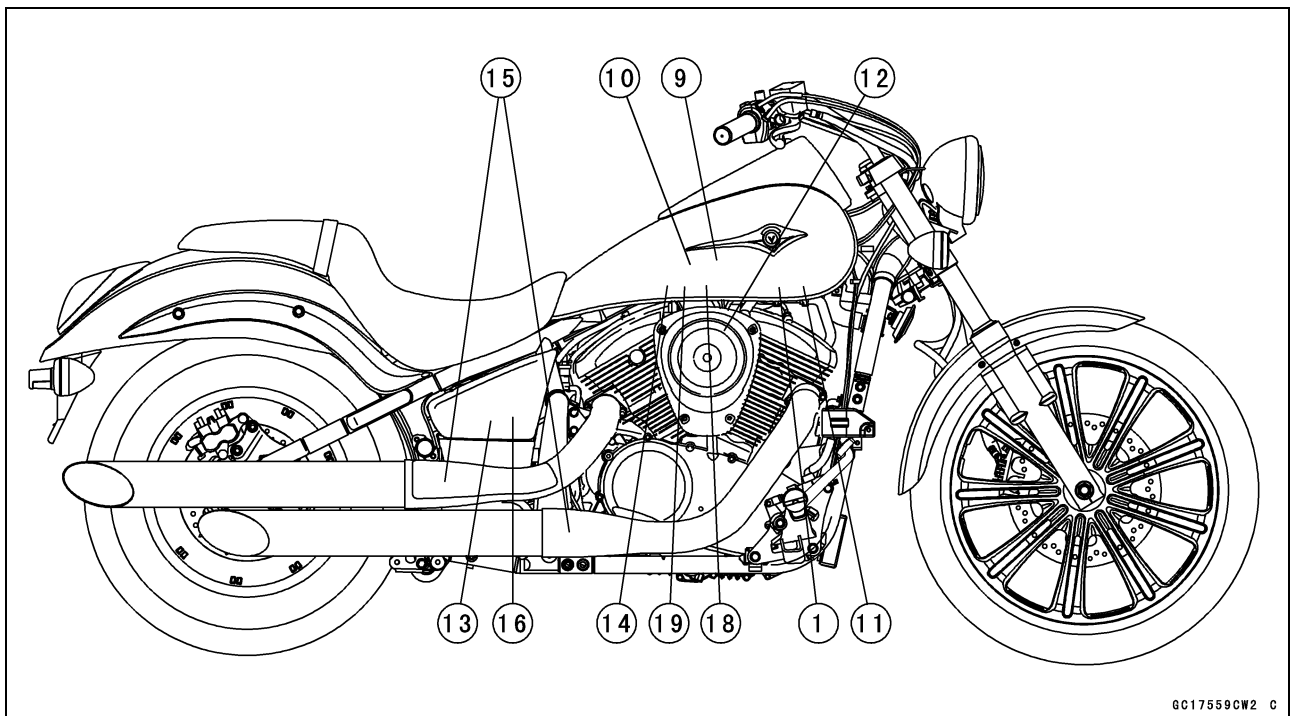

GC17559CW2 C

- | | |
|-------------------------------|---|
| 1. Air Switching Valve | 12. Inlet Air Temperature Sensor |
| 2. Battery | 13. Main Fuse 30 A |
| 3. Crankshaft Sensor | 14. Main Throttle Sensor |
| 4. ECU | 15. Oxygen Sensors (Oxygen Sensor Equipped Models) |
| 5. Fuel Pump | 16. Relay Box |
| 6. Fuse Box | 17. Speed Sensor |
| 7. Ignition Coil #1 | 18. Subthrottle Sensor |
| 8. Ignition Coil #2 | 19. Subthrottle Valve Actuator |
| 9. Injector #1 | 20. Vehicle-down Sensor |
| 10. Injector #2 | 21. Water Temperature Sensor |
| 11. Inlet Air Pressure Sensor | |

3-12 FUEL SYSTEM (DFI)

DFI Parts Location

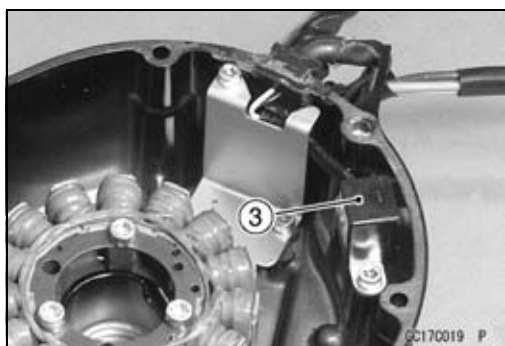
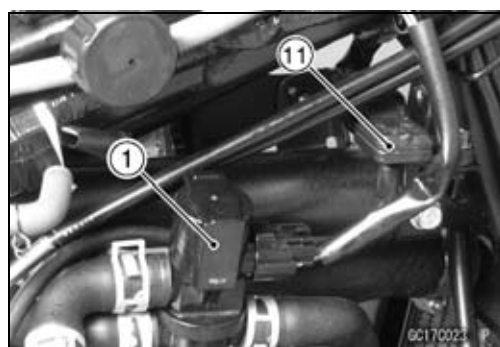
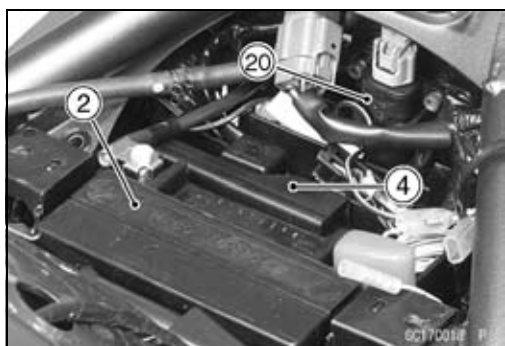
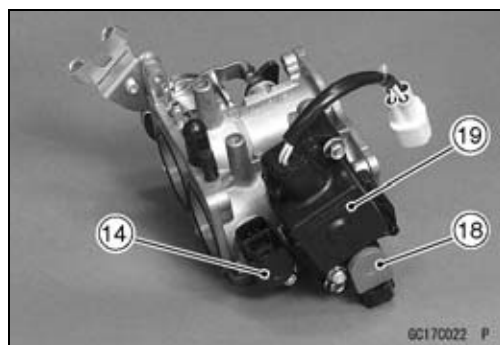
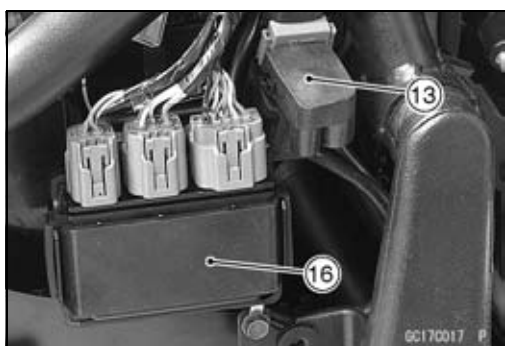
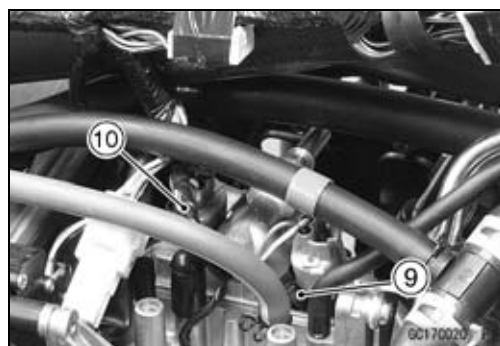
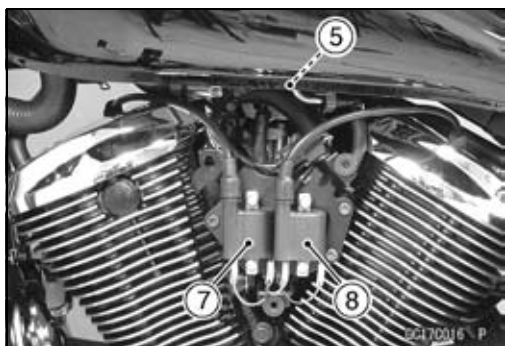

DFI Parts Location

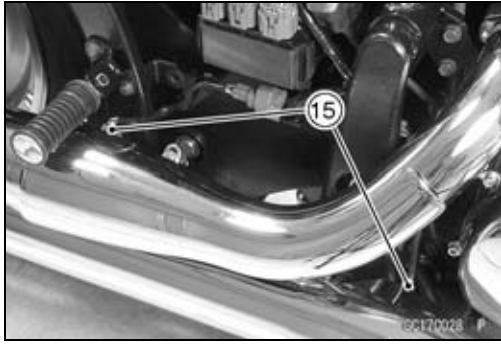

3-14 FUEL SYSTEM (DFI)

DFI System

DFI System

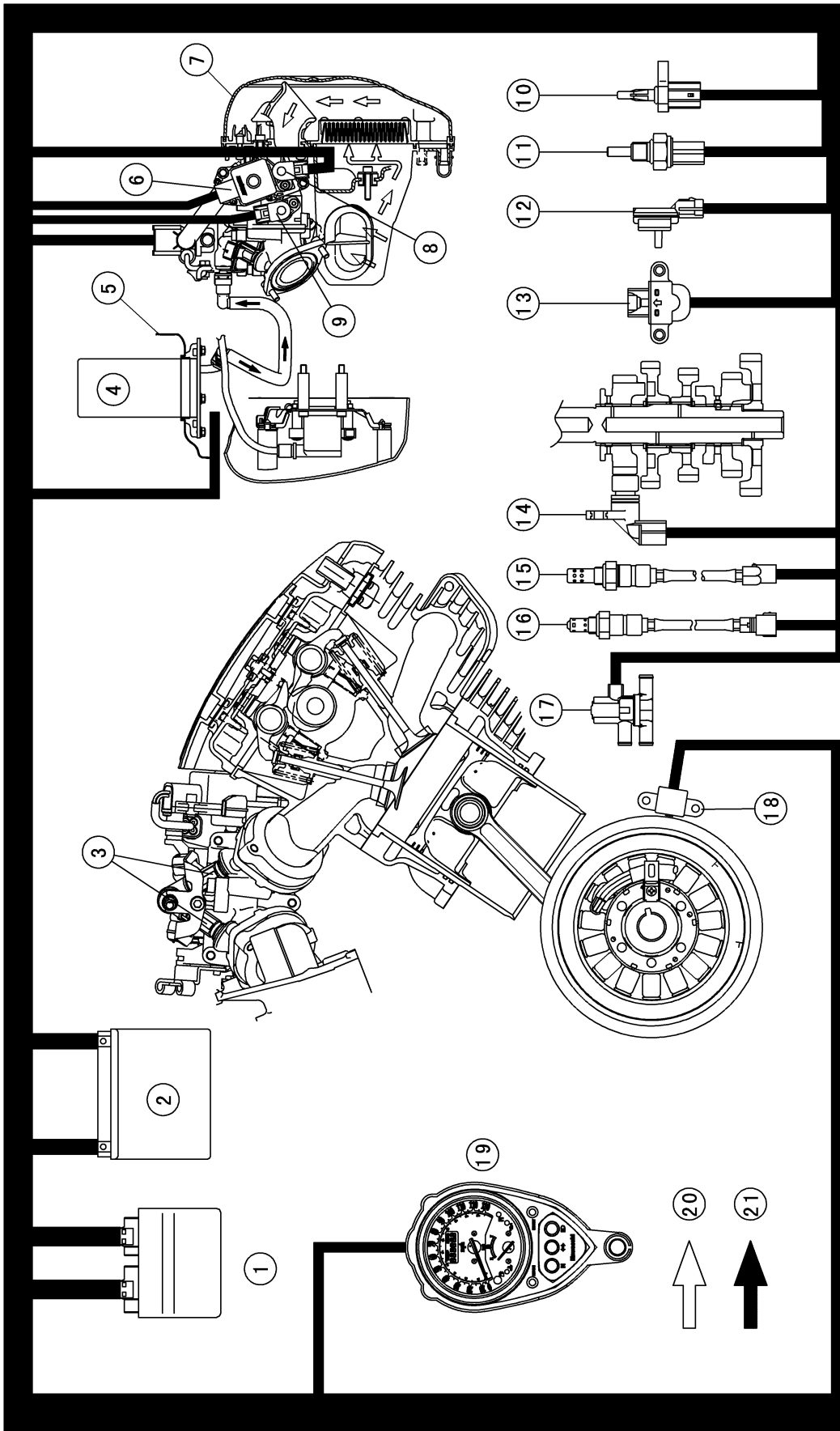

DFI System

1. ECU
2. Battery
3. Injectors
4. Fuel Pump
5. Fuel Tank
6. Subthrottle Valve Actuator
7. Air Cleaner
8. Subthrottle Sensor
9. Main Throttle Sensor
10. Inlet Air Temperature Sensor
11. Water Temperature Sensor
12. Inlet Air Pressure Sensor
13. Vehicle-down Sensor
14. Speed Sensor
15. Oxygen Sensors (Oxygen Sensor Equipped Models: VN900C7 ~ C8)
16. Oxygen Sensors (Oxygen Sensor Equipped Models: VN900C9 ~)
17. Air Switching Valve
18. Crankshaft Sensor
19. FI Indicator Light (LED)
20. Air Flow
21. Fuel Flow

3-16 FUEL SYSTEM (DFI)

DFI System

DFI System Wiring Diagram (Without Oxygen Sensor Equipped Models) (VN900C7 ~ C8)

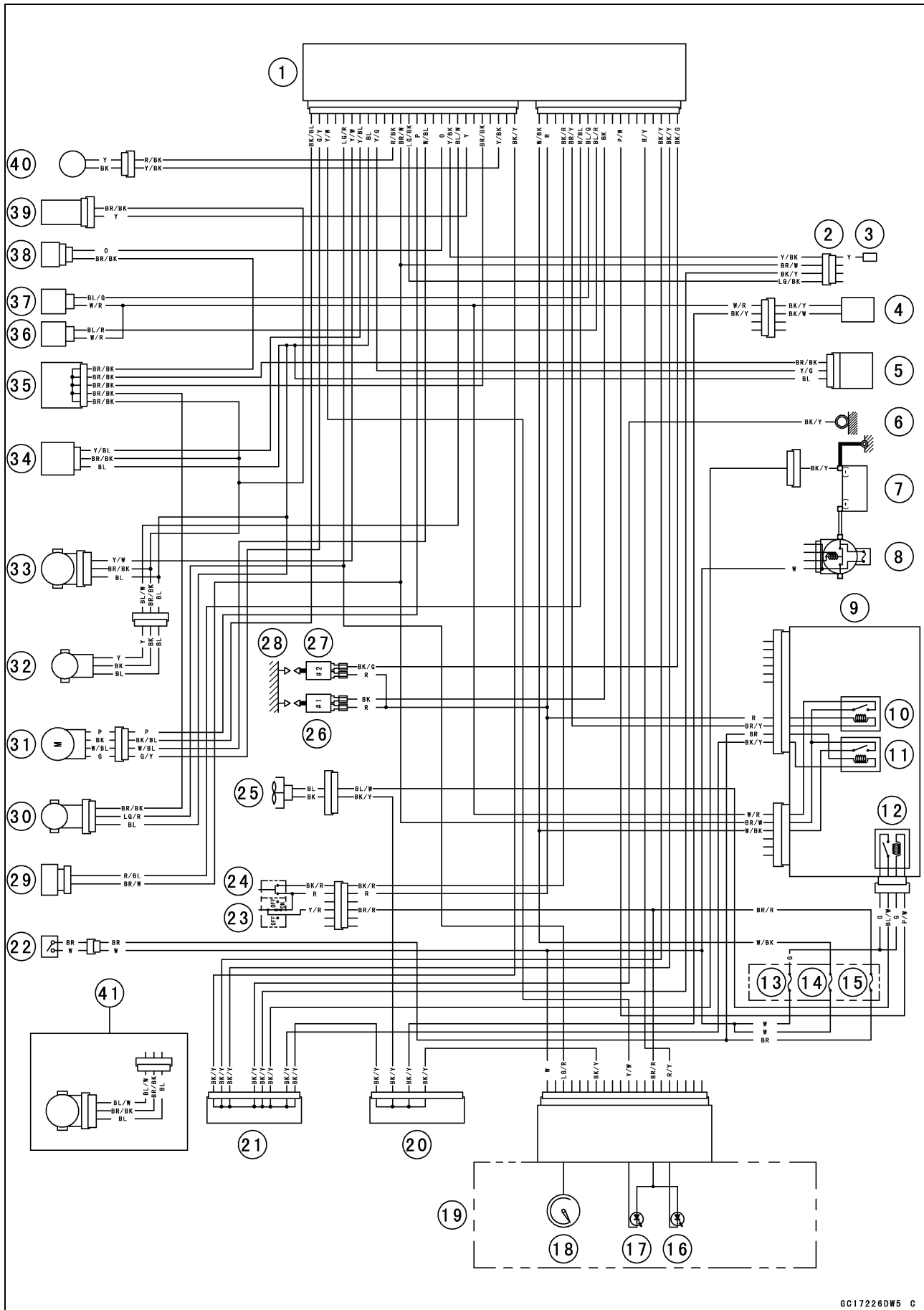

DFI System

Part Name

1. ECU
2. Diagnosis Connector
3. Self-diagnosis Terminal
4. Fuel Pump
5. Vehicle-down Sensor
6. Frame Ground
7. Battery
8. Main Fuse 30 A
9. Relay Box
10. Fuel Pump Relay
11. ECU Main Relay
12. Radiator Fan Relay
13. Radiator Fan Fuse 15 A
14. ECU Fuse 15 A
15. Ignition Fuse 10 A
16. FI Indicator Light (LED)
17. Water Temperature Warning Indicator Light (LED)
18. Speedometer
19. Meter Unit
20. Joint Connector A
21. Joint Connector C
22. Ignition Switch
23. Engine Stop Switch
24. Starter Button
25. Fan Motor
26. Ignition Coil #1
27. Ignition Coil #2
28. Spark Plugs
29. Air Switching Valve
30. Speed Sensor
31. Subthrottle Valve Actuator
32. Subthrottle Sensor (VN900C8 Models)
33. Main Throttle Sensor
34. Inlet Air Pressure Sensor
35. Joint Connector B
36. Injector #1
37. Injector #2
38. Water Temperature Sensor
39. Inlet Air Temperature Sensor
40. Crankshaft Sensor
41. Subthrottle Sensor (VN900C7 Models)

3-18 FUEL SYSTEM (DFI)

DFI System

DFI System Wiring Diagram (Oxygen Sensor Equipped Models) (VN900C7 ~ C8)

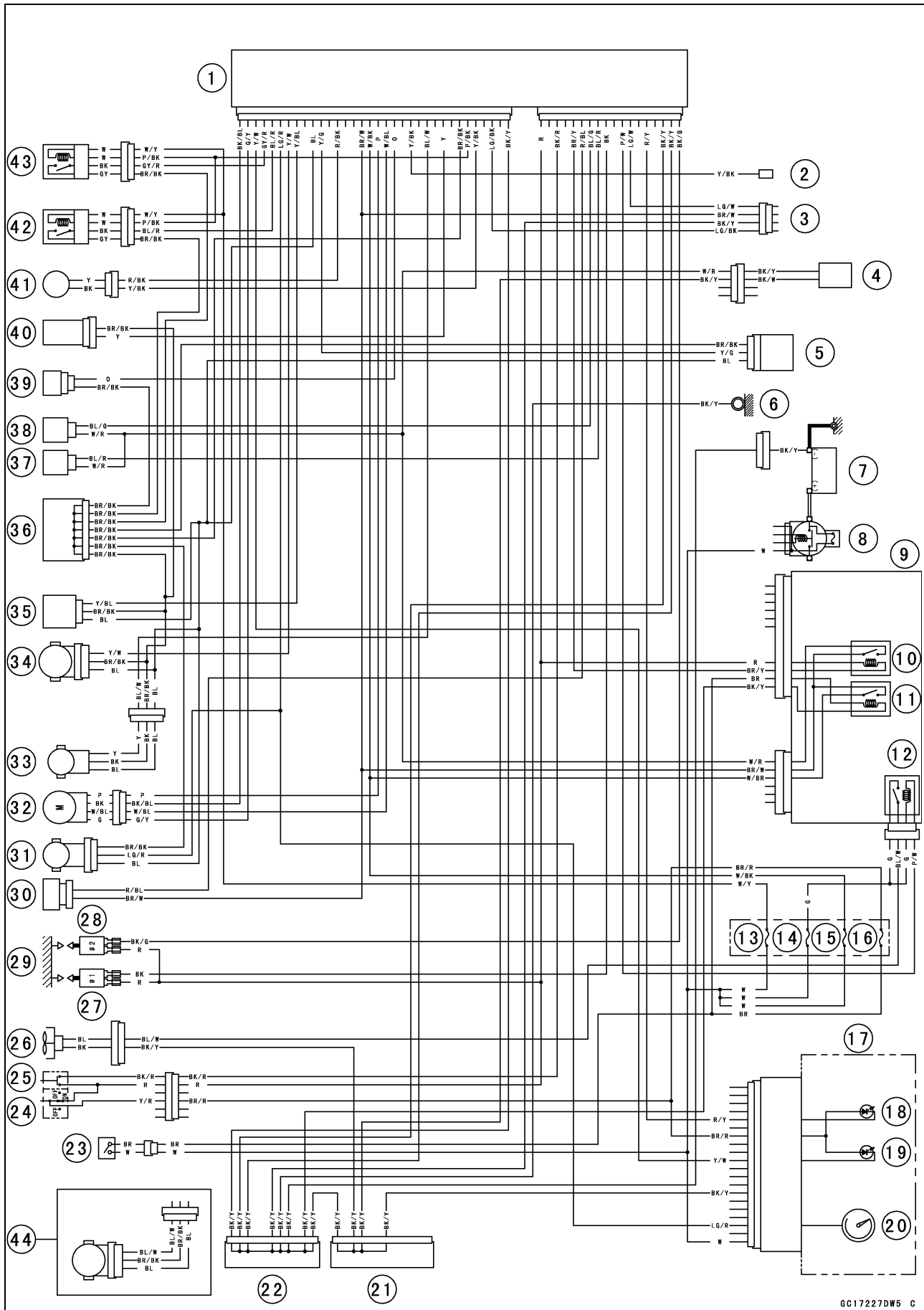

GC17227DW5 C

DFI System

Part Name

1. ECU
2. Diagnosis Connector
3. Self-diagnosis Terminal
4. Fuel Pump
5. Vehicle-down Sensor
6. Frame Ground
7. Battery
8. Main Fuse 30 A
9. Relay Box
10. Fuel Pump Relay
11. ECU Main Relay
12. Radiator Fan Relay
13. Oxygen Sensor Heater Fuse 10 A
14. Radiator Fan Fuse 15 A
15. ECU Fuse 15 A
16. Ignition Fuse 10 A
17. Meter Unit
18. FI Indicator Light (LED)
19. Water Temperature Warning Indicator Light (LED)
20. Speedometer
21. Joint Connector A
22. Joint Connector C
23. Ignition Switch
24. Engine Stop Switch
25. Starter Button
26. Fan Motor
27. Ignition Coil #1
28. Ignition Coil #2
29. Spark Plugs
30. Air Switching Valve
31. Speed Sensor
32. Subthrottle Valve Actuator
33. Subthrottle Sensor (VN900C8 Models)
34. Main Throttle Sensor
35. Inlet Air Pressure Sensor
36. Joint Connector B
37. Injector #1
38. Injector #2
39. Water Temperature Sensor
40. Inlet Air Temperature Sensor
41. Crankshaft Sensor
42. Oxygen Sensor #1
43. Oxygen Sensor #2
44. Subthrottle Sensor (VN900C7 Models)

3-20 FUEL SYSTEM (DFI)

DFI System

DFI System Wiring Diagram (Without Oxygen Sensor Equipped Models) (VN900C9 ~)

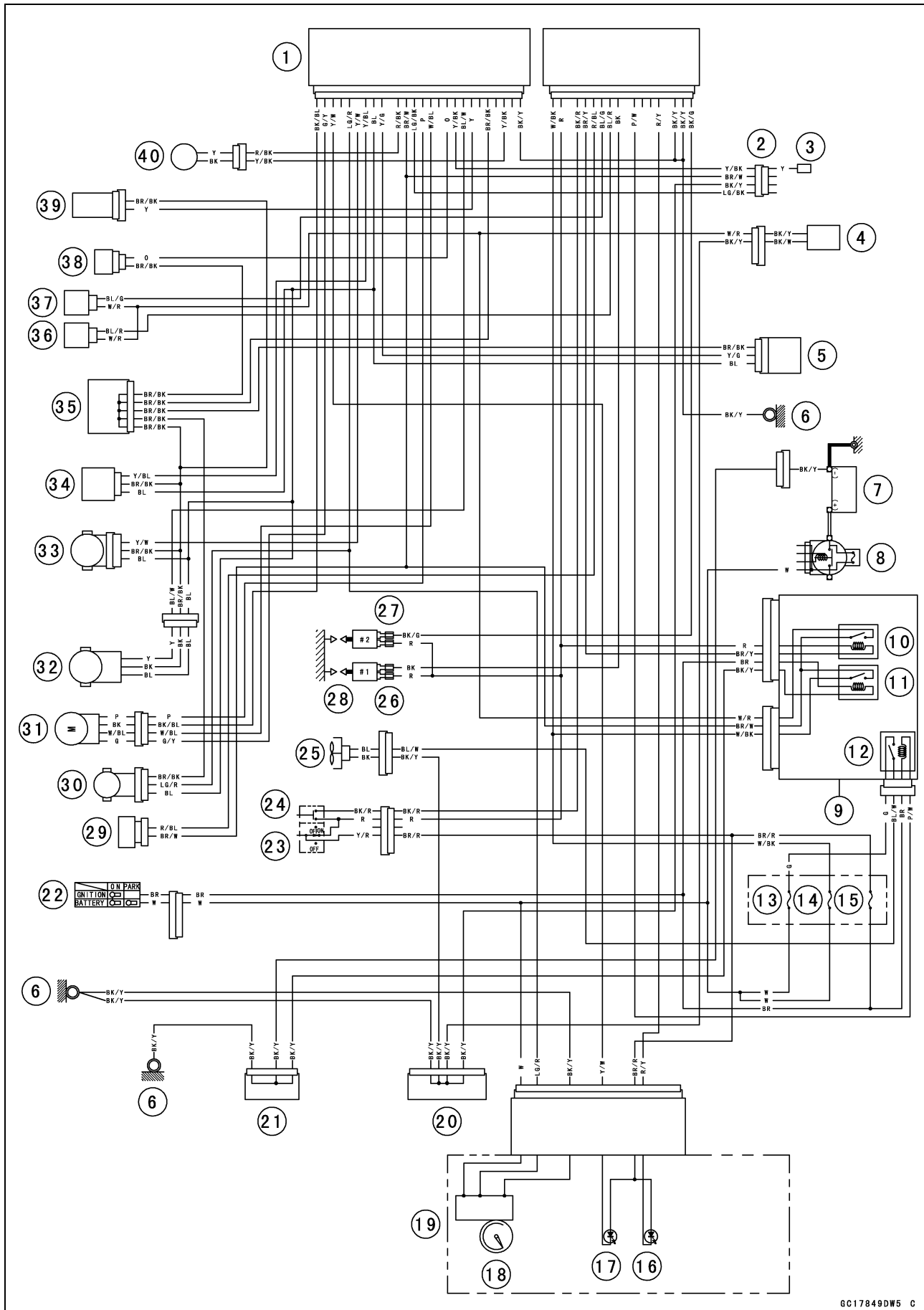

DFI System

Part Name

1. ECU
2. Diagnosis Connector
3. Self-diagnosis Terminal
4. Fuel Pump
5. Vehicle-down Sensor
6. Frame Ground
7. Battery
8. Main Fuse 30 A
9. Relay Box
10. Fuel Pump Relay
11. ECU Main Relay
12. Radiator Fan Relay
13. Radiator Fan Fuse 15 A
14. ECU Fuse 15 A
15. Ignition Fuse 10 A
16. FI Indicator Light (LED)
17. Water Temperature Warning Indicator Light (LED)
18. Speedometer
19. Meter Unit
20. Joint Connector A
21. Joint Connector C
22. Ignition Switch
23. Engine Stop Switch
24. Starter Button
25. Fan Motor
26. Ignition Coil #1
27. Ignition Coil #2
28. Spark Plugs
29. Air Switching Valve
30. Speed Sensor
31. Subthrottle Valve Actuator
32. Subthrottle Sensor
33. Main Throttle Sensor
34. Inlet Air Pressure Sensor
35. Joint Connector B
36. Injector #1
37. Injector #2
38. Water Temperature Sensor
39. Inlet Air Temperature Sensor
40. Crankshaft Sensor

3-22 FUEL SYSTEM (DFI)

DFI System

DFI System Wiring Diagram (Oxygen Sensor Equipped Models) (VN900C9 ~)

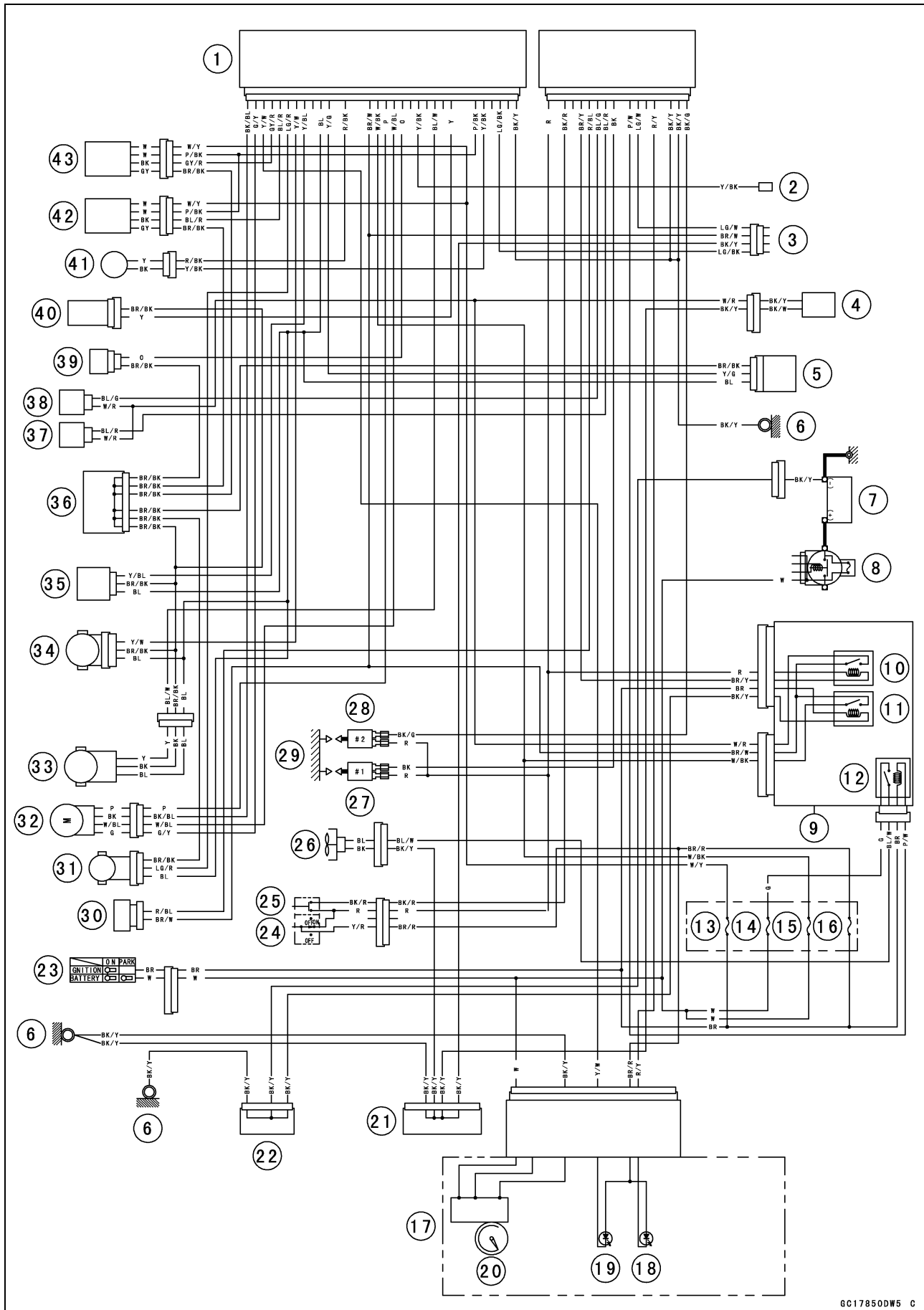

DFI System

Part Name

1. ECU
2. Diagnosis Connector
3. Self-diagnosis Terminal
4. Fuel Pump
5. Vehicle-down Sensor
6. Frame Ground
7. Battery
8. Main Fuse 30 A
9. Relay Box
10. Fuel Pump Relay
11. ECU Main Relay
12. Radiator Fan Relay
13. Oxygen Sensor Heater Fuse 10 A
14. Radiator Fan Fuse 15 A
15. ECU Fuse 15 A
16. Ignition Fuse 10 A
17. Meter Unit
18. FI Indicator Light (LED)
19. Water Temperature Warning Indicator Light (LED)
20. Speedometer
21. Joint Connector A
22. Joint Connector C
23. Ignition Switch
24. Engine Stop Switch
25. Starter Button
26. Fan Motor
27. Ignition Coil #1
28. Ignition Coil #2
29. Spark Plugs
30. Air Switching Valve
31. Speed Sensor
32. Subthrottle Valve Actuator
33. Subthrottle Sensor
34. Main Throttle Sensor
35. Inlet Air Pressure Sensor
36. Joint Connector B
37. Injector #1
38. Injector #2
39. Water Temperature Sensor
40. Inlet Air Temperature Sensor
41. Crankshaft Sensor
42. Oxygen Sensor #1
43. Oxygen Sensor #2

3-24 FUEL SYSTEM (DFI)

DFI System

Without Oxygen Sensor Equipped Models

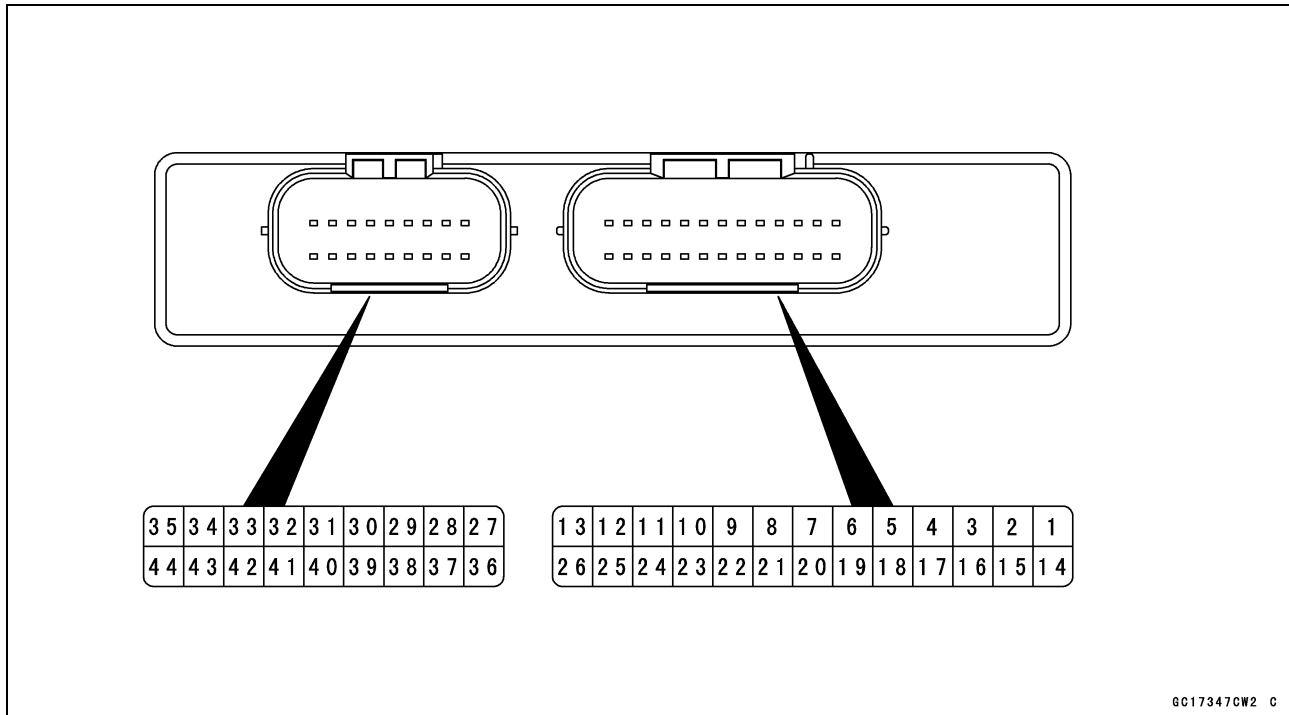

6C17347CW2 C

Terminal Names

- | | |
|---|--|
| 1. Subthrottle Valve Actuator Drive Signal 2 | 23. Unused |
| 2. Subthrottle Valve Actuator Drive Signal 1 | 24. Crankshaft Sensor (-) Signal |
| 3. Water Temperature Warning Light Signal | 25. Unused |
| 4. Unused | 26. Ground for ECU |
| 5. Speed Sensor Signal | 27. Power Supply to ECU (from Battery) |
| 6. Main Throttle Sensor Signal | 28. Engine Stop Switch Signal |
| 7. Inlet Air Pressure Sensor Signal | 29. Starter Lockout Switch Signal |
| 8. Power Supply to Sensors | 30. Starter Button Signal |
| 9. Vehicle-down Sensor Signal | 31. Fuel Pump Relay Signal |
| 10. Neutral Switch Signal | 32. Air Switching Valve Signal |
| 11. Crankshaft Sensor (+) Signal | 33. Fuel Injector #2 Signal |
| 12. Power Supply to ECU (from ECU Main Relay) | 34. Fuel Injector #1 Signal |
| 13. External Diagnosis System Signal | 35. Ignition Coil #1 Signal |
| 14. Subthrottle Valve Actuator Drive Signal 4 | 36. Sidestand Switch Signal |
| 15. Subthrottle Valve Actuator Drive Signal 3 | 37. Radiator Fan Relay Signal |
| 16. Unused | 38. Unused |
| 17. Water Temperature Sensor Signal | 39. Unused |
| 18. Self-diagnosis Terminal | 40. FI Indicator Light (LED) |
| 19. Subthrottle Sensor Signal | 41. - |
| 20. Inlet Air Temperature Sensor Signal | 42. Ground for Fuel System |
| 21. Unused | 43. Ground for ignition System |
| 22. Ground for Sensors | 44. Ignition Coil #2 Signal |

DFI System

Oxygen Sensor Equipped Models

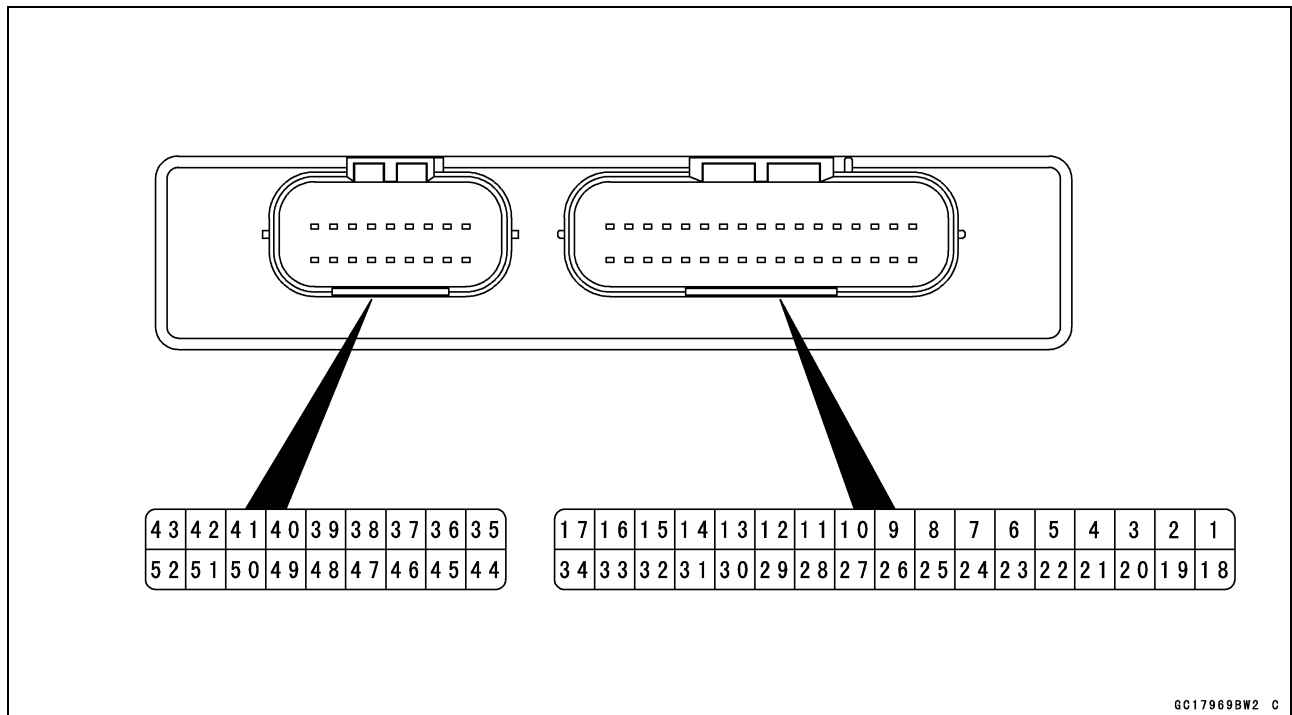

Terminal Names

- | | |
|--|---|
| <ul style="list-style-type: none"> 1. Subthrottle Valve Actuator Drive Signal 2 2. Subthrottle Valve Actuator Drive Signal 1 3. Water Temperature Warning Light Signal 4. Oxygen Sensor Signal 2 5. Oxygen Sensor Signal 1 6. Speed Sensor Signal 7. Main Throttle Sensor Signal 8. Inlet Air Pressure Sensor Signal 9. Unused 10. Power Supply to Sensors 11. Vehicle-down Sensor Signal 12. Neutral Switch Signal 13. Crankshaft Sensor (+) Signal 14. Unused 15. Unused 16. Power Supply to ECU (from ECU Main Relay) 17. Power Supply to ECU (from Battery) 18. Subthrottle Valve Actuator Drive Signal 4 19. Subthrottle Valve Actuator Drive Signal 3 20. Water Temperature Sensor Signal 21. Unused 22. Self-diagnosis Terminal 23. Unused 24. Subthrottle Sensor Signal 25. Unused 26. Inlet Air Temperature Sensor Signal | <ul style="list-style-type: none"> 27. Unused 28. Ground for Sensors 29. Oxygen Sensor Heater Signal 30. Crankshaft Sensor (-) Signal 31. Unused 32. External Diagnosis System Signal 33. Unused 34. Ground for ECU 35. Engine Stop Switch Signal 36. Starter Lockout Switch Signal 37. Starter Button Signal 38. Unused 39. Fuel Pump Relay Signal 40. Air Switching Valve Signal 41. Fuel Injector #2 Signal 42. Fuel Injector #1 Signal 43. Ignition Coil #1 Signal 44. Sidestand Switch Signal 45. Radiator Fan Relay Signal 46. Unused 47. Unused 48. FI Indicator Light (LED) 49. - 50. Ground for Fuel System 51. Ground for ignition System 52. Ignition Coil #2 Signal |
|--|---|

3-26 FUEL SYSTEM (DFI)

DFI Servicing Precautions

DFI Servicing Precautions

There are a number of important precautions that should be followed servicing the DFI system.

- This DFI system is designed to be used with a 12 V sealed battery as its power source. Do not use any other battery except for a 12 V sealed battery as a power source.
- Do not reverse the battery cable connections. This will damage the ECU.
- To prevent damage to the DFI parts, do not disconnect the battery cables or any other electrical connections when the ignition switch is on or while the engine is running.
- Take care not to short the leads that are directly connected to the battery positive (+) terminal to the chassis ground.
- When charging, remove the battery from the motorcycle. This is to prevent ECU damage by excessive voltage.
- Do not turn the ignition switch ON while any of the DFI electrical connectors are disconnected. The ECU memorizes service codes.
- Do not spray water on the electrical parts, DFI parts, connectors, leads, and wiring.
- Whenever the DFI electrical connections are to be disconnected, first turn off the ignition switch, and disconnect the battery (–) terminal. Do not pull the lead, only the connector. Conversely, make sure that all the DFI electrical connections are firmly reconnected before starting the engine.
- Connect these connectors until they click [A].

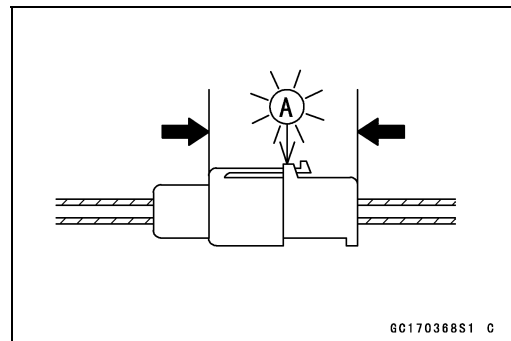

- If a transceiver is installed on the motorcycle, make sure that the operation of the DFI system is not influenced by electric wave radiated from the antenna. Check operation of the system with the engine at idle. Locate the antenna as far as possible away from the ECU.
- When any fuel hose is disconnected, fuel may spout out by residual pressure in the fuel line. Cover the hose joint with a piece of clean cloth to prevent fuel spillage.
- When any fuel hose is disconnected, do not turn on the ignition switch. Otherwise, the fuel pump will operate and fuel will spout from the fuel hose.
- Do not operate the fuel pump if the pump is completely dry. This is to prevent pump seizure.
- Before removing the fuel system parts, blow the outer surfaces of these parts clean with compressed air.
- To prevent corrosion and deposits in the fuel system, do not add to fuel any fuel antifreeze chemicals.

DFI Servicing Precautions

- To maintain the correct fuel/air mixture (F/A), there must be no inlet air leaks in the DFI system. Be sure to install the oil filler plug [A] after filling the engine oil.
Alternator Cover [B]

Special Tool - Filler Cap Driver: 57001-1454

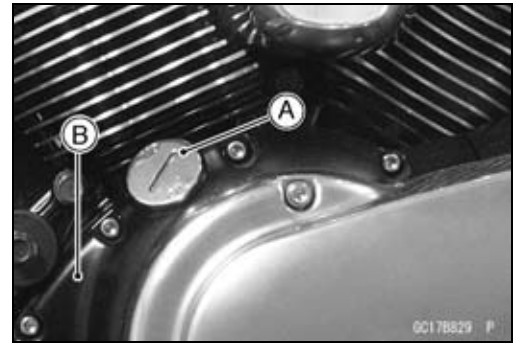

3-28 FUEL SYSTEM (DFI)

Troubleshooting the DFI System

Outline

Outline

When an abnormality in the system occurs, the FI indicator light (LED) goes on to alert the rider on the meter panel. In addition, the condition of the problem is stored in the memory of the ECU (Electronic Control Unit). With the engine stopped and turned in the self-diagnosis mode, the service code [A] is indicated by the number of times the FI indicator light (LED) blinks.

When due to a malfunction, the FI indicator light (LED) remains lit, ask the rider about the conditions [B] under which the problem occurred and try to determine the cause [C].

- First, conduct a self-diagnosis inspection and then a non-self-diagnosis inspection. The non-self-diagnosis items are not indicated by the FI indicator light (LED). Don't rely solely on the DFI self-diagnosis function, use common sense.

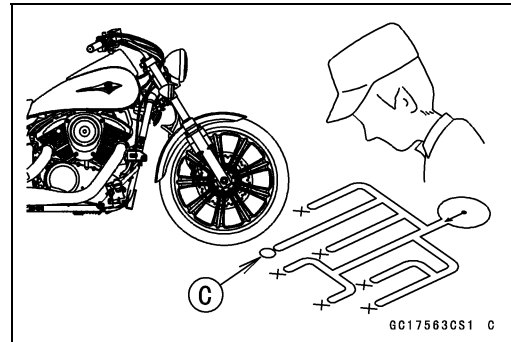
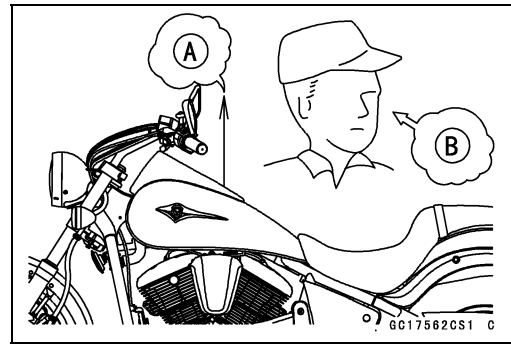

Even when the DFI system is operating normally, the FI indicator light (LED) [A] may light up under strong electrical interference. No repair needed. Turn the ignition switch OFF to stop the indicator light.

When the FI indicator light (LED) goes on and the motorcycle is brought in for repair, check the service codes.

When the repair has been done, the light (LED) doesn't go on. But the service codes stored in memory are not erased to preserve the problem history, and the light (LED) can display the codes in the self-diagnosis mode. The problem history is referred when solving unstable problems.

When the motorcycle is down, the vehicle-down sensor is turned OFF and the ECU shuts off the fuel injectors and ignition system. The FI indicator light (LED) blinks but the service code cannot be displayed. The ignition switch is left ON. If the starter button is pushed, the electric starter turns but the engine doesn't start. To start the engine again, raise the motorcycle, turn the ignition switch OFF, and then ON. The vehicle-down sensor is turned ON and the light (LED) goes OFF.



Troubleshooting the DFI System

- The DFI part connectors [A] have seals [B], including the ECU.
- Join the connector and insert the needle adapters [C] inside the seals from behind the connector until the adapter reaches the terminal.

Special Tool - Needle Adapter Set: 57001-1457

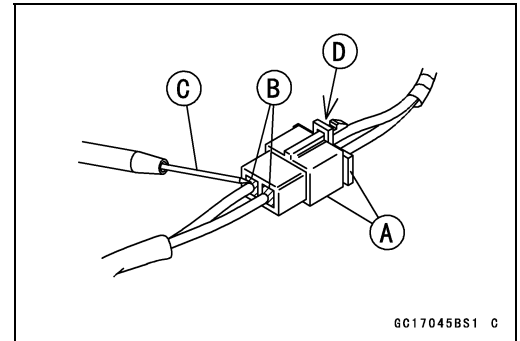

NOTICE

Insert the needle adapter straight along the terminal in the connector to prevent short-circuit between terminals.

- Make sure that measuring points are correct in the connector, noting the position of the lock [D] and the lead color before measurement. Do not reverse connections of a digital meter.
- Be careful not to short-circuit the leads of the DFI or electrical system parts by contact between adapters.
- Turn the ignition switch ON and measure the voltage with the connector joined.

NOTICE

Incorrect, reverse connection or short circuit by needle adapters could damage the DFI or electrical system parts.

- After measurement, remove the needle adapters and apply silicone sealant to the seals [A] of the connector [B] for waterproofing.

Sealant - Liquid Gasket, TB1211: 56019-120

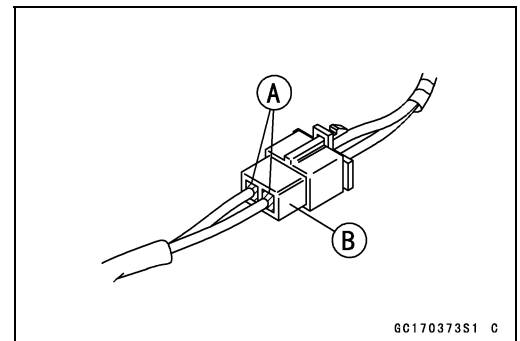

- Always check battery condition before replacing the DFI parts. A fully charged battery is a must for conducting accurate tests of the DFI system.
- Trouble may involve one or in some cases all items. Never replace a defective part without determining what CAUSED the problem. If the problem was caused by some other item or items, they too must be repaired or replaced, or the new replacement part will soon fail again.
- Measure coil winding resistance when the DFI part is cold (at room temperature).
- Make sure all connectors in the circuit are clean and tight, and examine wires for signs of burning, fraying, short, etc. Deteriorated wires and bad connections can cause reappearance of problems and unstable operation of the DFI system.
- ★ If any wiring is deteriorated, replace the wiring.

3-30 FUEL SYSTEM (DFI)

Troubleshooting the DFI System

- Pull each connector [A] apart and inspect it for corrosion, dirt, and damage.
- ★ If the connector is corroded or dirty, clean it carefully. If it is damaged, replace it. Connect the connectors securely.
- Check the wiring for continuity.
- Use the wiring diagram to find the ends of the lead which is suspected of being a problem.
- Connect a tester between the ends of the leads.
- ★ If the tester does not read 0 Ω , the lead is defective. Replace the lead or the main harness or the sub harness.

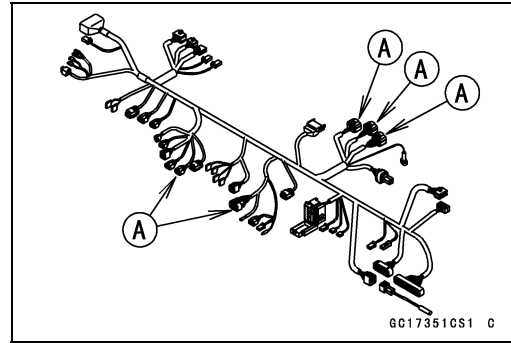

- If both ends of a harness [A] are far apart, ground [B] the one end [C], using a jumper lead [D] and check the continuity between the end [E] and the ground [F]. This enables to check a long harness for continuity. If the harness is open, repair or replace the harness.

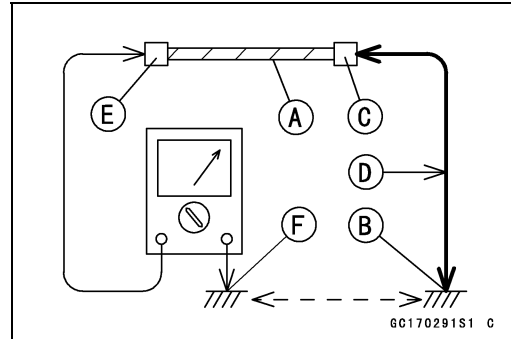

- When checking a harness [A] for short circuit, open one end [B] and check the continuity between the other end [C] and ground [D]. If there is continuity, the harness has a short circuit to ground, and it must be repaired or replaced.

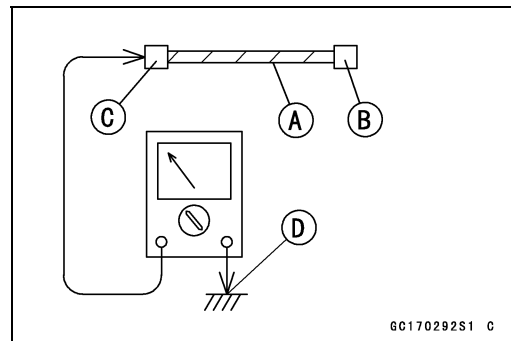

- Narrow down suspicious locations by repeating the continuity tests from the ECU connectors.
- ★ If no abnormality is found in the wiring or connectors, the DFI parts are the next likely suspects. Check the part, starting with input and output voltages. However, there is no way to check the ECU itself.
- ★ If an abnormality is found, replace the affected DFI part.
- ★ If no abnormality is found in the wiring, connectors, and DFI parts, replace the ECU.

○ Lead Color Codes:

| | | |
|----------------|-----------------|------------|
| BK: Black | G: Green | P: Pink |
| BL: Blue | GY: Gray | PU: Purple |
| BR: Brown | LB: Light Blue | R: Red |
| CH: Chocolate | LG: Light Green | W: White |
| DG: Dark Green | O: Orange | Y: Yellow |

Troubleshooting the DFI System

○ There are two ways to inspect the DFI system. One is Voltage Check Method and the other is Resistance Check Method.

(Voltage Check Method)

- This method is conducted by measuring the input voltage [A] to a sensor [B] first, and then the output voltage [C] from the sensor.
- Sometimes this method can detect a fault of the ECU.
- Refer to each sensor inspection section for detail in this chapter.
- Use a fully charged battery and a digital meter [D] which can be read two decimal places voltage or resistance.

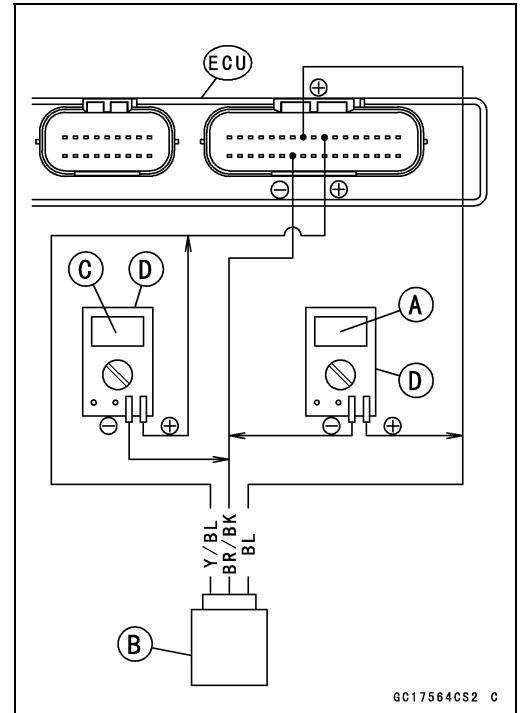

(Resistance Check Method)

- This method is simple. No need for a fully charged battery and the needle adapter. Just do the following especially when a sensor [A] is suspect.
- Turn the ignition switch OFF and disconnect the connectors.
- Inspect the sensor resistance, using a digital meter (see each sensor inspection).
- Inspect the wiring and connectors [B] for continuity, using a tester [C] (analog tester) rather than a digital meter.
- ★ If the sensor, the wiring and connections are good, inspect the ECU for its ground and power supply (see ECU Power Supply Inspection). If the ground and power supply are good, the ECU is suspect. Replace the ECU.

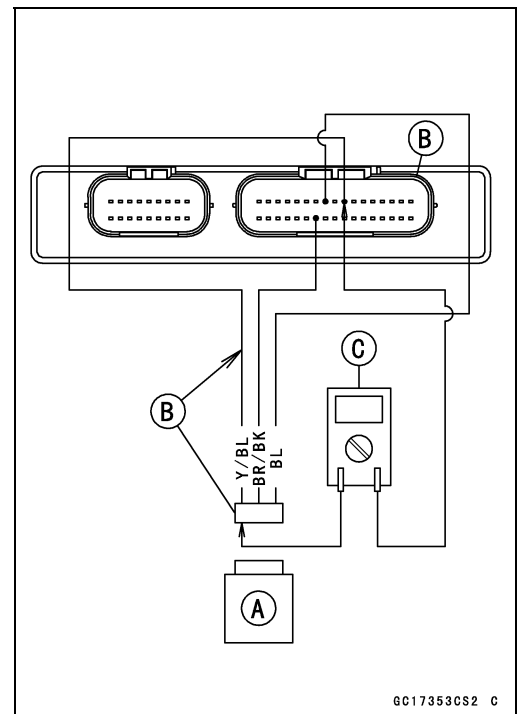

3-32 FUEL SYSTEM (DFI)

Troubleshooting the DFI System

DFI Diagnosis Flow Chart

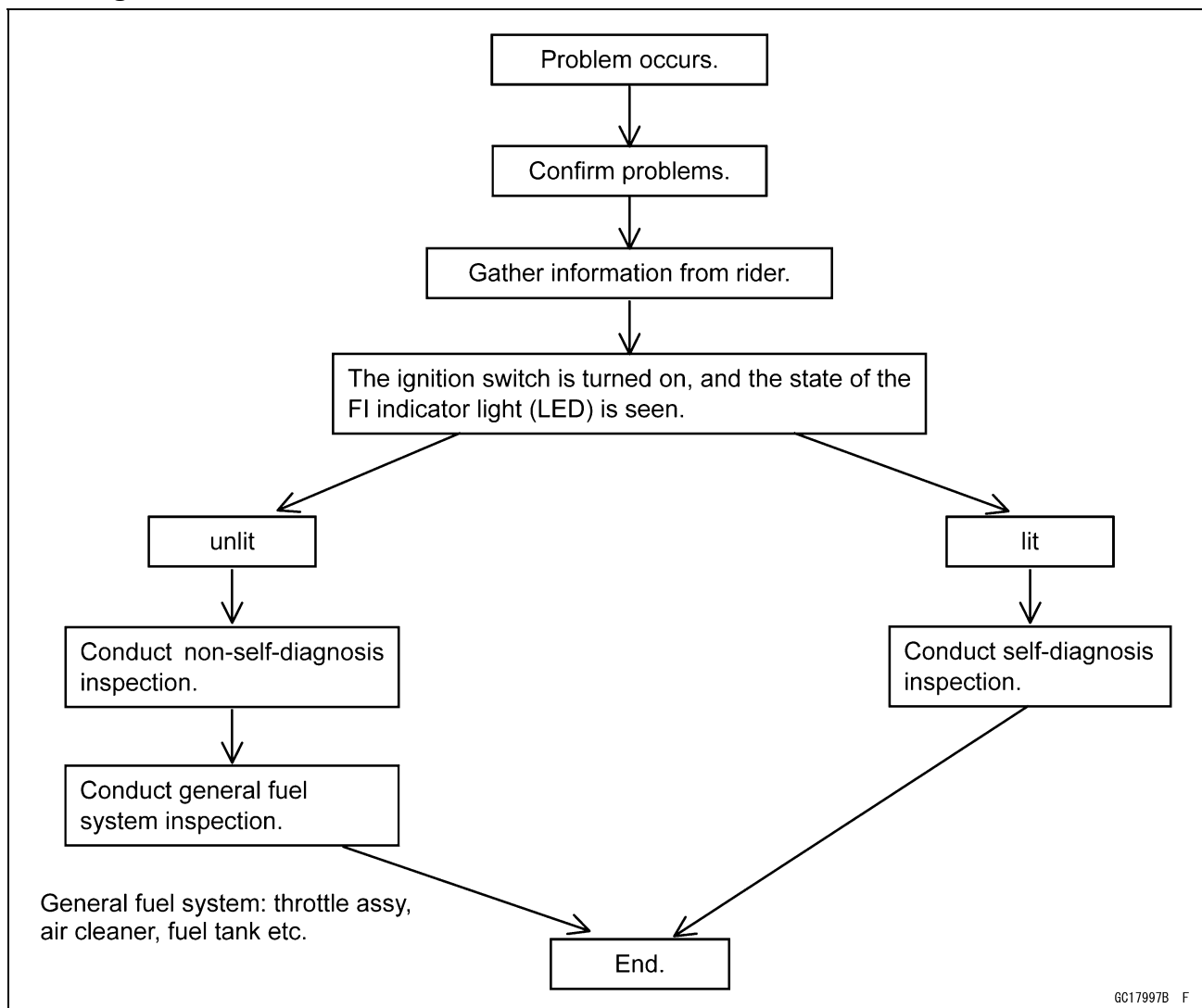

Inquiries to Rider

Inquiries to Rider

- Each rider reacts to problems in different ways, so it is important to confirm what kind of symptoms the rider has encountered.
- Try to find out exactly what problem occurred under exactly what conditions by asking the rider; knowing this information may help you reproduce the problem.
- The following sample diagnosis sheet will help prevent you from overlooking any areas, and will help you decide if it is a DFI system problem, or a general engine problem.

Troubleshooting the DFI System

Sample Diagnosis Sheet

| | | | |
|---|--|--|--|
| Rider name: | | Registration No. (license plate No.): | |
| Year of initial registration: | | Model: | |
| Engine No.: | | Frame No.: | |
| Date problem occurred: | | Mileage: | |
| Environment when problem occurred. | | | |
| Weather | <input type="checkbox"/> fine, <input type="checkbox"/> cloudy, <input type="checkbox"/> rain, <input type="checkbox"/> snow, <input type="checkbox"/> always, <input type="checkbox"/> other: | | |
| Temperature | <input type="checkbox"/> hot, <input type="checkbox"/> warm, <input type="checkbox"/> cold, <input type="checkbox"/> very cold, <input type="checkbox"/> always | | |
| Problem frequency | <input type="checkbox"/> chronic, <input type="checkbox"/> often, <input type="checkbox"/> once | | |
| Road | <input type="checkbox"/> street, <input type="checkbox"/> highway, <input type="checkbox"/> mountain road (<input type="checkbox"/> uphill, <input type="checkbox"/> downhill), <input type="checkbox"/> bumpy, <input type="checkbox"/> pebble | | |
| Altitude | <input type="checkbox"/> normal, <input type="checkbox"/> high (about 1 000 m or more) | | |
| Motorcycle conditions when problem occurred. | | | |
| FI indicator light (LED) | <input type="checkbox"/> light up immediately after ignition switch ON, and goes off after engine oil pressure is high enough (with engine running) (normal) | | |
| | <input type="checkbox"/> lights up immediately after ignition switch ON, and stays on after engine oil pressure is high enough (with engine running) (DFI problem) | | |
| | <input type="checkbox"/> lights up immediately after ignition switch ON, but goes off after about 10 seconds though engine oil pressure is high enough (with engine running) (DFI problem) | | |
| | <input type="checkbox"/> unlights (light (LED), ECU or its wiring fault) | | |
| | <input type="checkbox"/> sometimes lights up (probably wiring fault) | | |
| Starting difficulty | <input type="checkbox"/> starter motor not rotating | | |
| | <input type="checkbox"/> starter motor rotating but engine doesn't turn over | | |
| | <input type="checkbox"/> starter motor and engine don't turn over | | |
| | <input type="checkbox"/> no fuel flow (<input type="checkbox"/> no fuel in tank, <input type="checkbox"/> no fuel pump sound) | | |
| | <input type="checkbox"/> engine flooded (do not crank engine with throttle opened, which promotes engine flooding) | | |
| | <input type="checkbox"/> no spark | | |
| | <input type="checkbox"/> other | | |
| Engine stops | <input type="checkbox"/> right after starting | | |
| | <input type="checkbox"/> when opening throttle grip | | |
| | <input type="checkbox"/> when closing throttle grip | | |
| | <input type="checkbox"/> when moving off | | |
| | <input type="checkbox"/> when stopping the motorcycle | | |
| | <input type="checkbox"/> when cruising | | |
| | <input type="checkbox"/> other | | |
| Poor running at low speed | <input type="checkbox"/> very low fast idle speed | | |
| | <input type="checkbox"/> very low idle speed, <input type="checkbox"/> very high idle speed, <input type="checkbox"/> rough idle speed | | |
| | <input type="checkbox"/> battery voltage is low (charge the battery) | | |
| | <input type="checkbox"/> spark plug loose (tighten it) | | |
| | <input type="checkbox"/> spark plug dirty, broken, or gap maladjusted (remedy it) | | |
| | <input type="checkbox"/> backfiring | | |
| | <input type="checkbox"/> afterfiring | | |
| | <input type="checkbox"/> hesitation when acceleration | | |
| | <input type="checkbox"/> engine oil viscosity too high | | |
| <input type="checkbox"/> brake dragging | | | |

3-34 FUEL SYSTEM (DFI)

Troubleshooting the DFI System

| | |
|--|---|
| | <input type="checkbox"/> engine overheating |
| | <input type="checkbox"/> clutch slipping |
| | <input type="checkbox"/> other |
| Poor running or no power at high speed | <input type="checkbox"/> spark plug loose (tighten it) |
| | <input type="checkbox"/> spark plug dirty, broken, or gap maladjusted (remedy it) |
| | <input type="checkbox"/> spark plug incorrect (replace it) |
| | <input type="checkbox"/> knocking (fuel poor quality or incorrect) |
| | <input type="checkbox"/> brake dragging |
| | <input type="checkbox"/> clutch slipping |
| | <input type="checkbox"/> engine overheating |
| | <input type="checkbox"/> engine oil level too high |
| | <input type="checkbox"/> engine oil viscosity too high |
| | <input type="checkbox"/> other |

DFI System Troubleshooting Guide

NOTE

- This is not an exhaustive list, giving every possible cause for each problem listed. It is meant simply as a rough guide to assist the troubleshooting for some of the more common difficulties.
- The ECU may be involved in the DFI electrical and ignition system troubles. If these parts and circuits are checked out good, be sure to check the ECU for ground and power supply. If the ground and power supply are checked good, replace the ECU.

Engine Doesn't Start, Starting Difficulty

| Symptoms or Possible Causes | Actions (chapter) |
|---|--|
| Starter motor not rotating: | |
| Ignition and engine stop switches not ON | Turn both switches ON. |
| Starter lockout switch or neutral switch trouble | Inspect (see chapter 16). |
| Starter motor trouble | Inspect (see chapter 16). |
| Battery voltage low | Inspect and charge (see chapter 16). |
| Starter relays not contacting or operating | Inspect the starter relay (see chapter 16). |
| Starter button not contacting | Inspect and replace (see chapter 16). |
| Starter system wiring open or shorted | Inspect the wiring (see chapter 16). |
| Ignition switch trouble | Inspect and replace (see chapter 16). |
| Engine stop switch trouble | Inspect and repair or replace (see chapter 16). |
| Main 30 A or ignition fuse blown | Inspect and replace (see chapter 16). |
| Starter motor rotating but engine doesn't turn over: | |
| Starter clutch trouble | Inspect (see chapter 9). |
| Starter idle gear trouble | Inspect (see chapter 9). |
| Engine won't turn over: | |
| Valve seizure | Inspect and replace (see chapter 5). |
| Rocker arm seizure | Inspect and replace (see chapter 5). |
| Cylinder, piston seizure | Inspect and replace (see chapter 5). |
| Camshaft seizure | Inspect and replace (see chapter 5). |
| Connecting rod small end seizure | Inspect and replace (see chapter 9). |
| Connecting rod big end seizure | Inspect and replace (see chapter 9). |
| Crankshaft seizure | Inspect and replace (see chapter 9). |
| Transmission gear or bearing seizure | Inspect and replace (see chapter 9). |
| Balancer bearing seizure | Inspect and replace (see chapter 9). |
| No fuel flow: | |
| No or little fuel in tank | Supply fuel (see Owner's Manual). |
| Fuel pump not rotating | Inspect (see chapter 3). |
| Fuel injector trouble | Inspect and replace (see chapter 3). |
| Fuel tank air vent obstructed | Inspect and repair (see chapter 3). |
| Fuel filter or pump screen clogged | Inspect and replace fuel pump (see chapter 3). |
| Fuel pressure regulator clogged | Inspect and replace fuel pump (see chapter 3). |
| Fuel line clogged | Inspect and repair (see chapter 3). |
| Engine flooded: | |
| Spark plug dirty, broken or gap maladjusted | Clean spark plugs and adjust plug gap (see chapter 2). |
| Starting technique faulty | When flooded, don't crank engine with throttle fully opened. |

3-36 FUEL SYSTEM (DFI)

DFI System Troubleshooting Guide

| Symptoms or Possible Causes | Actions (chapter) |
|--|--|
| No spark or spark weak: | |
| Ignition and engine stop switches not ON | Turn both switches ON. |
| Clutch lever not pulled in and gear not in neutral whether sidestand up or not | Pull the lever in and shift the gear in neutral. |
| Though clutch lever pulled in but sidestand up and gear not in neutral | Sidestand down and clutch lever pulled in whether gear in neutral, or not. |
| Vehicle-down sensor coming off | Reinstall (see chapter 3). |
| Vehicle-down sensor trouble | Inspect (see chapter 3). |
| ECU ground or power supply trouble | Inspect (see chapter 3). |
| Battery voltage low | Inspect and charge (see chapter 16). |
| Spark plug dirty, broken or gap maladjusted | Clean spark plug and adjust plug gap (see chapter 2). |
| Spark plug cap or high tension wiring trouble | Inspect the ignition coil (see chapter 16). |
| Spark plug cap shorted or not in good contact | Reinstall or inspect the cap (see chapter 16). |
| Spark plug incorrect | Replace it with the correct plug (see chapter 16). |
| IC igniter in ECU trouble | Inspect (see chapter 16). |
| Neutral, starter lockout or sidestand switch trouble | Inspect each switch (see chapter 16). |
| Crankshaft sensor trouble | Inspect (see chapter 16). |
| Ignition coil trouble | Inspect (see chapter 16). |
| Ignition switch shorted | Inspect and replace (see chapter 16). |
| Engine stop switch shorted | Inspect and repair or replace (see chapter 16). |
| Starter system wiring shorted or open | Inspect and repair or replace (see chapter 16). |
| Main 30 A or ignition fuse blown | Inspect and replace (see chapter 16). |
| Fuel/air mixture incorrect: | |
| Air cleaner clogged, poorly sealed or missing | Clean or reinstall (see chapter 3). |
| Leak from oil filler cap, crankcase breather hose or air cleaner drain hose | Inspect and repair or replace (see chapter 3). |
| Water or foreign matter in fuel | Change fuel. Inspect and clean fuel system (see chapter 3). |
| Fuel pressure regulator trouble | Inspect fuel pressure and replace fuel pump (see chapter 3). |
| Main throttle sensor trouble | Inspect (see chapter 3). |
| Fuel pressure may be low | Inspect (see chapter 3). |
| Fuel pump trouble | Inspect (see chapter 3). |
| Fuel injector trouble | Inspect (see chapter 3). |
| Inlet air pressure sensor trouble | Inspect (see chapter 3). |
| Inlet air temperature sensor trouble | Inspect (see chapter 3). |
| Water temperature sensor trouble | Inspect (see chapter 3). |
| Throttle valves or actuator trouble | Inspect (see chapter 3). |
| Crankshaft sensor trouble | Inspect (see chapter 3). |
| Compression low: | |
| Spark plug loose | Reinstall (see chapter 16). |
| Cylinder head not sufficiently tightened down | Tighten (see chapter 5). |
| Cylinder, piston worn | Inspect and replace (see chapter 5). |

DFI System Troubleshooting Guide

| Symptoms or Possible Causes | Actions (chapter) |
|---|--|
| Piston ring bad (worn, weak, broken or sticking) | Inspect and replace (see chapter 5). |
| Piston ring/groove clearance excessive | Inspect and replace (see chapter 5). |
| Cylinder head gasket damaged | Replace (see chapter 5). |
| Cylinder head warped | Inspect and replace (see chapter 5). |
| Valve guide worn | Inspect and replace (see chapter 5). |
| Valve spring broken or weak | Inspect and replace (see chapter 5). |
| Valve not seating properly (valve bent, worn or carbon accumulating on seating surface) | Inspect and repair or replace (see chapter 5). |

Poor Running at Low Speed

| Symptoms or Possible Causes | Actions (chapter) |
|--|--|
| Spark weak: | |
| Battery voltage low | Inspect and charge (see chapter 16). |
| Spark plug dirty, broken or gap maladjusted | Clean spark plugs and adjust plug gap (see chapter 2). |
| Spark plug cap or high tension wiring trouble | Inspect the ignition coil (see chapter 16). |
| Spark plug cap shorted or not in good contact | Reinstall or inspect the cap (see chapter 16). |
| Spark plug incorrect | Replace it with the correct plug (see chapter 16). |
| IC igniter in ECU trouble | Inspect (see chapter 16). |
| Crankshaft sensor trouble | Inspect (see chapter 16). |
| Ignition coil trouble | Inspect (see chapter 16). |
| Fuel/air mixture incorrect: | |
| Little fuel in tank | Supply fuel (see Owner's Manual). |
| Air cleaner clogged, poorly sealed, or missing | Clean element or inspect sealing (see chapter 3). |
| Air cleaner duct loose | Reinstall (see chapter 3). |
| Air cleaner O-ring damaged | Replace (see chapter 3). |
| Fuel tank air vent obstructed | Inspect and repair (see chapter 3). |
| Throttle body assy loose | Reinstall (see chapter 3). |
| Throttle body assy O-ring damage | Replace (see chapter 3). |
| Throttle valves or actuator trouble | Push in (see chapter 3). |
| Fuel filter or pump screen clogged | Inspect and replace fuel pump (see chapter 3). |
| Fuel pressure regulator clogged | Inspect fuel pressure and replace fuel pump (see chapter 3). |
| Fuel line clogged | Inspect and repair (see chapter 3). |
| Thermostat trouble | Inspect and replace (see chapter 4). |
| Inlet air temperature sensor trouble | Inspect (see chapter 3). |
| Inlet air pressure sensor trouble | Inspect (see chapter 3). |
| Unstable (rough) idling: | |
| Throttle valves or actuator trouble | Inspect (see chapter 3). |
| Fuel injector trouble | Inspect (see chapter 3). |
| Main throttle sensor trouble | Inspect (see chapter 3). |
| Inlet air temperature sensor trouble | Inspect (see chapter 3). |
| Water temperature sensor trouble | Inspect (see chapter 3). |
| Fuel pressure too low or too high | Inspect (see chapter 3). |
| Battery voltage low | Inspect and charge (see chapter 16). |

3-38 FUEL SYSTEM (DFI)

DFI System Troubleshooting Guide

| Symptoms or Possible Causes | Actions (chapter) |
|---|---|
| Incorrect idle speed: | |
| Water temperature sensor trouble | Inspect (see chapter 3). |
| Main throttle sensor trouble | Inspect (see chapter 3). |
| Throttle valves or actuator trouble | Inspect (see chapter 3). |
| Engine stalls easily: | |
| Fuel pump trouble | Inspect (see chapter 3). |
| Fuel injector trouble | Inspect (see chapter 3). |
| Main throttle sensor trouble (engine stops when opening the throttle) | Inspect (see chapter 3). |
| Fuel pressure too low or too high | Inspect (see chapter 3). |
| Inlet air temperature sensor trouble | Inspect (see chapter 3). |
| Fuel pressure too low or too high | Inspect (see chapter 3). |
| Fuel pressure regulator trouble | Inspect and replace (see chapter 3). |
| Crankshaft sensor trouble | Inspect (see chapter 16). |
| Ignition coil trouble | Inspect (see chapter 16). |
| Compression Low: | |
| Spark plug loose | Reinstall (see chapter 16). |
| Cylinder head not sufficiently tightened down | Tighten (see chapter 5). |
| Cylinder, piston worn | Inspect and replace (see chapter 5). |
| Piston ring bad (worn, weak, broken or sticking) | Inspect and replace (see chapter 5). |
| Piston ring/groove clearance excessive | Inspect and replace (see chapter 5). |
| Cylinder head gasket damaged | Replace (see chapter 5). |
| Cylinder head warped | Inspect and replace (see chapter 5). |
| Valve guide worn or stem seal damaged | Inspect and replace (see chapter 5). |
| Valve spring broken or weak | Inspect and replace (see chapter 5). |
| Valve not seating properly (valve bent, worn or carbon accumulating on seating surface) | Inspect and repair or replace (see chapter 5). |
| Camshaft cam worn | Inspect and replace (see chapter 5). |
| Hesitation: | |
| Too low fuel pressure | Inspect (see chapter 3). |
| Clogged fuel line | Inspect and repair (see chapter 3). |
| Cracked or obstructed inlet air pressure sensor hose | Inspect and repair or replace (see chapter 3). |
| Fuel pump trouble | Inspect (see chapter 3). |
| Fuel injector trouble | Inspect (see chapter 3). |
| Inlet air temperature sensor trouble | Inspect (see chapter 3). |
| Main throttle sensor malfunction | Inspect (see chapter 3). |
| Water temperature sensor trouble | Inspect (see chapter 3). |
| Inlet air pressure sensor trouble | Inspect (see chapter 3). |
| Loose injector connectors | Remedy (see chapter 3). |
| Crankshaft sensor trouble | Inspect and repair or replace (see chapter 16). |
| Ignition coil trouble | Inspect and repair or replace (see chapter 16). |
| Loose terminal of battery (-) cable or engine ground lead | Inspect and repair (see chapter 16). |

DFI System Troubleshooting Guide

| Symptoms or Possible Causes | Actions (chapter) |
|---|---|
| Delay of ignition timing | Inspect crankshaft sensor and IC igniter in ECU (see chapter 16). |
| Poor acceleration: | |
| Too low fuel pressure | Inspect (see chapter 3). |
| Water or foreign matter in fuel | Change fuel. Inspect and clean fuel system (see chapter 3). |
| Clogged fuel filter | Inspect and replace fuel pump (see chapter 3). |
| Fuel pump trouble | Inspect (see chapter 3). |
| Fuel injector trouble | Inspect (see chapter 3). |
| Inlet air temperature sensor trouble | Inspect (see chapter 3). |
| Water temperature sensor trouble | Inspect (see chapter 3). |
| Ignition coil trouble | Inspect and replace (see chapter 16). |
| Engine oil level too high | Repair (see chapter 7). |
| Spark plug dirty, broken or gap maladjusted | Clean spark plugs and adjust plug gap (see chapter 2). |
| Stumble: | |
| Too low fuel pressure | Inspect (see chapter 3). |
| Fuel injector trouble | Inspect (see chapter 3). |
| Main throttle sensor malfunction | Inspect (see chapter 3). |
| Water temperature sensor trouble | Inspect (see chapter 3). |
| Inlet air pressure sensor trouble | Inspect (see chapter 3). |
| Surge: | |
| Unstable fuel pressure | Fuel pressure regulator trouble (Inspect and replace fuel pump) or kinked fuel line (Inspect and repair fuel line) (see chapter 3). |
| Fuel injector trouble | Inspect (see chapter 3). |
| Water temperature sensor trouble | Inspect (see chapter 3). |
| Backfiring when deceleration: | |
| Spark plug dirty, broken or gap maladjusted | Clean spark plugs and adjust plug gap (see chapter 2). |
| Too low fuel pressure | Inspect (see chapter 3). |
| Crankshaft sensor trouble | Inspect (see chapter 3). |
| Fuel pump trouble | Inspect (see chapter 3). |
| Main throttle sensor malfunction | Inspect (see chapter 3). |
| Inlet air temperature sensor trouble | Inspect (see chapter 3). |
| Water temperature sensor trouble | Inspect (see chapter 3). |
| Inlet air pressure sensor trouble | Inspect (see chapter 3). |
| Air switching valve broken | Inspect and replace (see chapter 5 or 16). |
| Air suction valve trouble | Inspect and replace (see chapter 5). |
| After fire: | |
| Crankshaft sensor trouble | Inspect (see chapter 3). |
| Spark plug burned or gap maladjusted | Adjust plug gap or replace plug (see chapter 2). |
| Inlet air temperature sensor trouble | Inspect (see chapter 3). |
| Water temperature sensor trouble | Inspect (see chapter 3). |
| Inlet air pressure sensor trouble | Inspect (see chapter 3). |

3-40 FUEL SYSTEM (DFI)

DFI System Troubleshooting Guide

| Symptoms or Possible Causes | Actions (chapter) |
|---|---|
| Fuel injector trouble | Inspect (see chapter 3). |
| Run-on (dieseling): | |
| Ignition switch trouble | Inspect and replace (see chapter 16). |
| Engine switch trouble | Inspect and repair or replace (see chapter 2). |
| Fuel injector trouble | Inspect (see chapter 3). |
| Engine overheating | (see Overheating of Troubleshooting Guide, see chapter 17) |
| Other: | |
| Engine oil viscosity too high | Change (see chapter 2). |
| Drive belt trouble | Inspect and replace (see chapter 11). |
| Brake dragging | Inspect caliper fluid seal damage or clogging of master cylinder relief and supply ports (see chapter 12). |
| Clutch slipping | Inspect friction plates for wear (see chapter 6). |
| Engine overheating | (see Overheating of Troubleshooting Guide in chapter 17) |
| Air switching valve trouble | Inspect and replace (see chapter 5 or 16). |
| Air suction valve trouble | Inspect and replace (see chapter 5). |
| Intermittent any DFI fault and its recovery | Check that DFI connectors are clean and tight, and examine wires for signs of burning or fraying (see chapter 3). |

Poor Running or No Power at High Speed

| Symptoms or Possible Causes | Actions (chapter) |
|---|---|
| Firing incorrect: | |
| Spark plug dirty, broken or maladjusted | Clean spark plug and adjust plug gap (see chapter 2). |
| Spark plug cap or high tension wiring trouble | Inspect plug cap and ignition coil (see chapter 16). |
| Spark plug cap shorted or not in good contact | Reinstall or inspect the cap (see chapter 16). |
| Spark plug incorrect | Replace it with the correct plug (see chapter 16). |
| IC igniter in ECU trouble | Inspect (see chapter 16). |
| Crankshaft sensor trouble | Inspect (see chapter 16). |
| Ignition coil trouble | Inspect (see chapter 16). |
| Fuel/mixture incorrect: | |
| Air cleaner clogged, poorly sealed, or missing | Clean element or inspect sealing (see chapter 3). |
| Air cleaner duct loose | Reinstall (see chapter 3). |
| Air cleaner O-ring damaged | Replace (see chapter 3). |
| Water or foreign matter in fuel | Change fuel. Inspect and clean fuel system (see chapter 3). |
| Throttle body assy loose | Reinstall (see chapter 3). |
| Throttle body assy O-ring damaged | Replace (see chapter 3). |
| Fuel tank air vent obstructed | Inspect and repair (see chapter 3). |
| Fuel line clogged | Inspect and repair (see chapter 3). |
| Fuel pump operates intermittently and often DFI fuse blows. | Pump bearings may wear. Replace the pump (see chapter 3). |
| Fuel pump trouble | Inspect (see chapter 3). |

DFI System Troubleshooting Guide

| Symptoms or Possible Causes | Actions (chapter) |
|--|--|
| Inlet air temperature sensor trouble | Inspect (see chapter 3). |
| Main throttle sensor malfunction | Inspect (see chapter 3). |
| Inlet air pressure sensor trouble | Inspect (see chapter 3). |
| Cracked or obstructed inlet air pressure sensor hose | Inspect and repair or replace (see chapter 3). |
| Injector clogged | Visually inspect and replace (see chapter 3). |
| Compression low: | |
| Spark plug loose | Reinstall (see chapter 16). |
| Cylinder head not sufficiently tightened down | Tighten (see chapter 5). |
| Cylinder, piston worn | Inspect and replace (see chapter 5). |
| Piston ring bad (worn, weak, broken or sticking) | Inspect and replace (see chapter 5). |
| Piston ring/groove clearance excessive | Inspect and replace (see chapter 5). |
| Cylinder head gasket damaged | Replace (see chapter 5). |
| Cylinder head warped | Inspect and replace (see chapter 5). |
| Valve spring broken or weak | Inspect and replace (see chapter 5). |
| Valve not seating properly (valve bent , worn or carbon accumulating on the seating surface) | Inspect and repair or replace (see chapter 5). |
| Knocking: | |
| Carbon built up in combustion chamber | Repair (see chapter 5). |
| Fuel poor quality or incorrect (Use the gasoline recommended in the Owner's Manual) | Change fuel (see chapter 3). |
| Spark plug incorrect | Replace it with the correct plug (see chapter 16). |
| Ignition coil trouble | Inspect (see chapter 16). |
| IC igniter in ECU trouble | Inspect (see chapter 16). |
| Inlet air temperature sensor trouble | Inspect (see chapter 3). |
| Miscellaneous: | |
| Throttle valves won't fully open | Inspect throttle cable and lever linkage (see chapter 3). |
| Brake dragging | Inspect caliper fluid seal damage or clogging of master cylinder relief and supply ports (see chapter 12). |
| Clutch slipping | Inspect friction plates for wear (see chapter 6). |
| Engine overheating | (see Overheating of Troubleshooting Guide in chapter 17) |
| Engine oil level too high | Repair (see chapter 7). |
| Engine oil viscosity too high | Change (see chapter 2). |
| Drive belt trouble | Inspect and replace (see chapter 11). |
| Camshaft cam worn | Inspect and replace (see chapter 5). |
| Air switching valve trouble | Inspect and replace (see chapter 5 or 16). |
| Air suction valve trouble | Inspect and replace (see chapter 5). |
| Catalytic converters melt down due to muffler overheating | Replace muffler (see chapter 5). |
| Exhaust Smokes Excessively: | |
| (White smokes) | |
| Piston oil ring worn | Inspect and replace (see chapter 5). |
| Cylinder worn | Inspect and replace (see chapter 5). |

3-42 FUEL SYSTEM (DFI)

DFI System Troubleshooting Guide

| Symptoms or Possible Causes | Actions (chapter) |
|--------------------------------------|--|
| Valve oil seal damaged | Replace (see chapter 5). |
| Valve guide worn | Replace the guide (see chapter 5). |
| Engine oil level too high | Repair (see chapter 7). |
| (Black smoke) | |
| Air cleaner clogged | Clean (see chapter 3). |
| Too high fuel pressure | Inspect (see chapter 3). |
| Injection stuck open | Inspect (see chapter 3). |
| Water temperature sensor trouble | Inspect and replace (see chapter 3). |
| Inlet air temperature sensor trouble | Inspect and replace (see chapter 3). |
| (Brown smoke) | |
| Air cleaner duct loose | Reinstall (see chapter 3). |
| Air cleaner O-ring damaged | Replace (see chapter 3). |
| Too low fuel pressure | Inspect fuel line and fuel pump (see chapter 3). |
| Water temperature sensor trouble | Inspect and replace (see chapter 3). |
| Inlet air temperature sensor trouble | Inspect and replace (see chapter 3). |

Self-Diagnosis

Self-diagnosis Outline

Self-diagnosis Outline

The self-diagnosis system has three modes and can be switched to another mode by grounding the self-diagnosis terminal.

User Mode

The ECU notifies the rider of troubles in DFI system and ignition system by lighting the FI indicator when DFI system and ignition system parts are faulty, and initiates fail-safe function. In case of serious troubles, the ECU stops the injection/ignition/starter motor operation.

Dealer Mode 1

The FI indicator light (LED) emits service code(s) to show the problem(s) which the DFI system, and ignition system has at the moment of diagnosis.

Dealer Mode 2

The FI indicator light (LED) emits service code(s) to show the problem(s) which the DFI system, and ignition system had in the past.

Self-diagnosis Procedures

Self-diagnosis Procedures

○When a problem occurs with the DFI system and ignition system, the FI indicator light (LED) [A] goes on.

NOTE

- Use a fully charged battery when conducting self-diagnosis. Otherwise, the light (LED) blinks very slowly or doesn't blink.
- Keep the self-diagnosis terminal grounded during self-diagnosis, with an auxiliary lead.

- Remove the tool box (see Tool Box Removal in the Frame chapter).
- Ground the self-diagnosis terminal [A] (Yellow lead) to the battery (-) terminal or battery (-) cable connector, using a wire.

- Turn on the ignition switch.
- Connect an auxiliary lead [E] to the self-diagnosis terminal [G] for grounding.
- To enter the self-diagnosis dealer mode 1, ground [A] the self-diagnosis indicator terminal to the battery (-) terminal for more than 2 seconds [C], and then keep it grounded continuously [D].
- Count the blinks of the light (LED) to read the service code. Keep the auxiliary lead ground until you finish reading the service code.

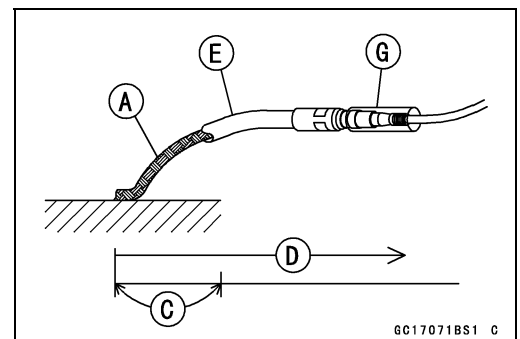

3-44 FUEL SYSTEM (DFI)

Self-Diagnosis

- To enter the self-diagnosis dealer mode 2, open [B] and ground [A] the lead more than five times [F] within 2 seconds [C] after the lead is first grounded, and then keep it grounded continuously [D] for more than 2 seconds.
- Count the blinks of the light (LED) to read the service code. Keep the auxiliary lead ground until you finish reading the service code.
 - Auxiliary Lead [E]
 - Self-diagnosis Terminal [G]

NOTE

- To enter the dealer mode 2 from the dealer mode 1, turn off the ignition switch once.

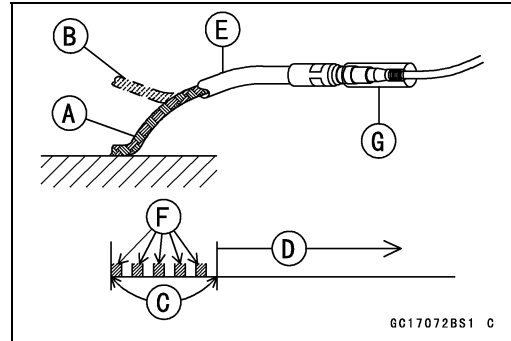

Service Code Clearing Procedures

Service Code Clearing Procedures

- Enter the self-diagnosis dealer mode 2 (see Self-diagnosis Procedures).

NOTE

- Make sure to keep the grounding until the following opening and grounding starts.
- Pull the clutch lever in more than 5 seconds, and then release it.
- Repeat opening [B] and grounding [A] the lead (self-diagnosis terminal) more than five times [F] within 2 seconds [C] after the lead is grounded, and then keep it grounded continuously [D] for more than 2 seconds.
 - Auxiliary Lead [E]
 - Self-diagnosis Terminal [G]

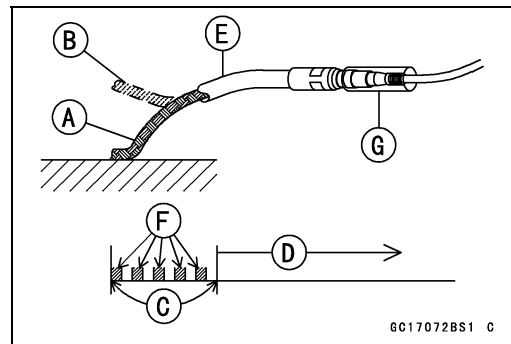

Self-Diagnosis

Self-Diagnosis Flow Chart

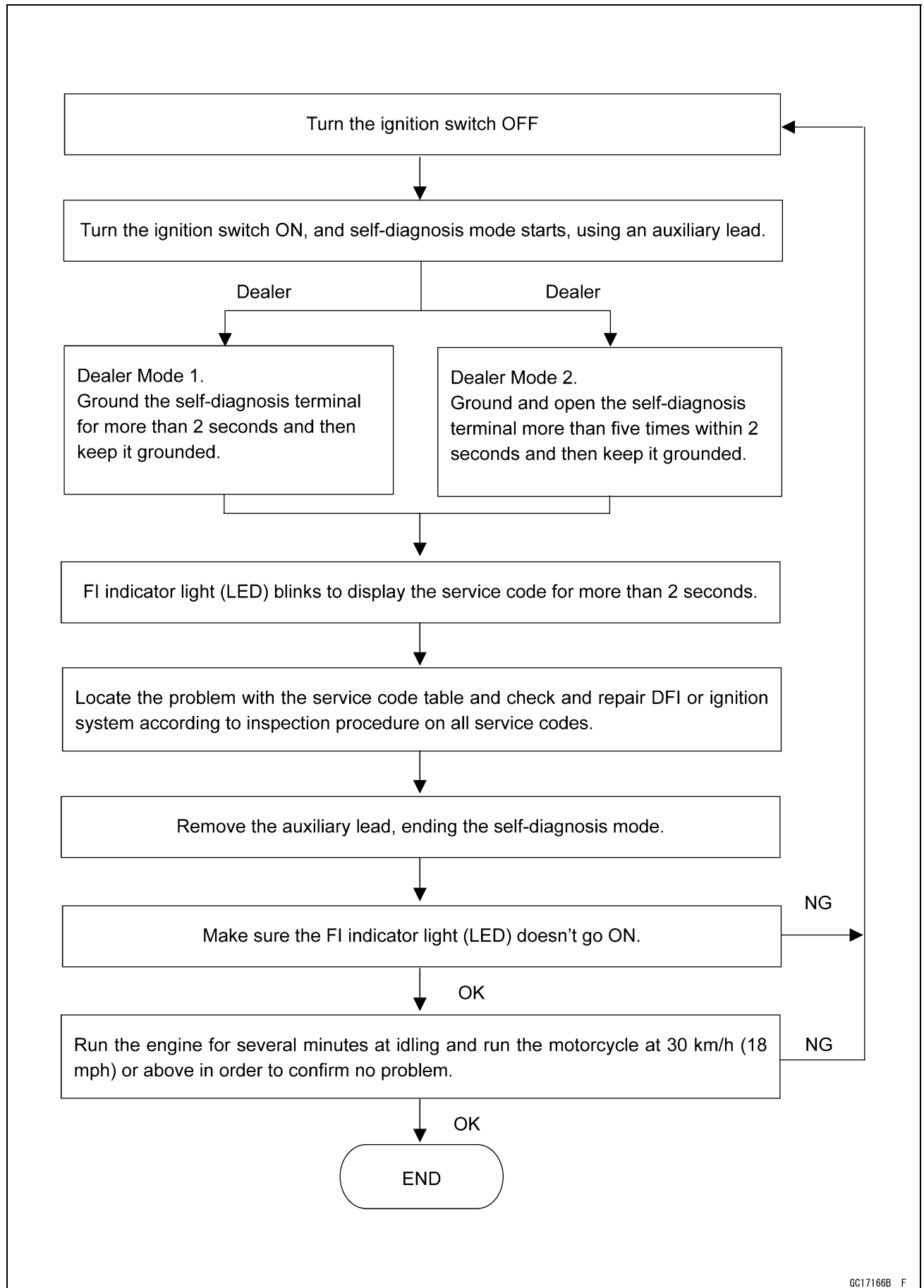

3-46 FUEL SYSTEM (DFI)

Self-Diagnosis

Service Code Reading

Service Code Reading

- Service codes are shown by a series of long and short blinks of the FI indicator light (LED) as shown below.
- Read 10th digit and unit digit as the FI indicator light (LED) blinks.
- When there are a number of problems, all the service codes can be stored and the display will begin starting from the lowest number service code in the numerical order. Then after completing all codes, the display is repeated until the self-diagnosis indicator terminal is open.
- If there is no problem, no code and unlight.
- For example, if two problems occurred in the order of 21, 12, the service codes are displayed from the lowest number in the order listed.
(12 → 21) → (12 → 21) → ··· (repeated)

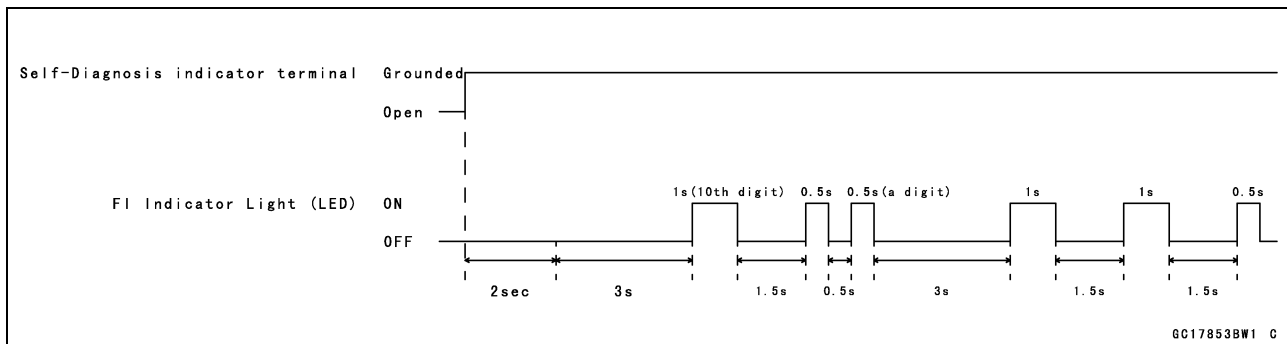

- If the problem is with the following parts, the ECU cannot memorize these problems, the FI indicator light (LED) doesn't go on, and no service codes can be displayed.
 - FI Indicator Light (LED)
 - Fuel Pump
 - Fuel Pump Relay
 - ECU Main Relay
 - ECU Power Source Wiring and Ground Wiring (see ECU Power Supply Inspection)
 - Fuel Injectors

Service Code Erasing











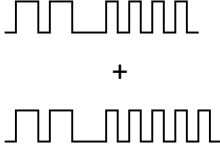

Service Code Erasing

- Even if the ignition switch is turned OFF, the battery or the ECU are disconnected or the problem is solved, all service codes remain in the ECU.
- Refer to the Service Code Clearing Procedure for the service code erasure.

Self-Diagnosis

Service Code Table

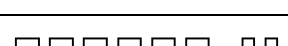
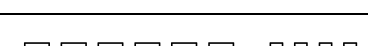
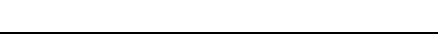
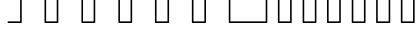
Service Code Table

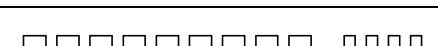
| Service Code | FI Indicator Light (LED) | Problems |
|--------------|---|---|
| 11 |  ON OFF | Main throttle sensor malfunction, wiring open or short |
| 12 |  | Inlet air pressure sensor malfunction, wiring open or short |
| 13 |  | Inlet air temperature sensor malfunction, wiring open or short |
| 14 |  | Water temperature sensor malfunction, wiring open or short |
| 21 |  | Crankshaft sensor malfunction, wiring open or short |
| 24 and 25 |  | Speed sensor malfunction, wiring open or short First 24 is displayed and then 25, repeatedly |
| 31 |  | Vehicle-down sensor, malfunction, wiring open or short |
| 32 |  | Subthrottle sensor malfunction, wiring open or short |
| 33 |  | Oxygen sensor #1 inactivation, wiring open or short (Oxygen Sensor Equipped Models) |
| 51 |  | Ignition coil #1 malfunction, wiring open or short |
| 52 |  | Ignition coil #2 malfunction, wiring open or short |
| 56 |  | Radiator fan relay malfunction, wiring open or short |
| 62 |  | Subthrottle valve actuator malfunction, wiring open or short |
| 64 |  | Air switching valve malfunction, wiring open or short |
| 67 |  | Oxygen sensor heater malfunction, wiring open or short (Oxygen Sensor Equipped Models) |
| 83 |  | Oxygen sensor #2 inactivation, wiring open or short (Oxygen Sensor Equipped Models) |
| 94 |  | Oxygen sensor #1 malfunction, wiring open or short (Oxygen Sensor Equipped Models) |
| 95 |  | Oxygen sensor #2 malfunction, wiring open or short (Oxygen Sensor Equipped Models) |

3-48 FUEL SYSTEM (DFI)

Self-Diagnosis

Notes:

- The ECU may be involved in these problems. If all the parts and circuits checked out good, be sure to check the ECU for ground and power supply. If the ground and power supply are checked good, replace the ECU.
- When no service code is displayed, the electrical parts of the DFI system has no fault, and the mechanical parts of the DFI system and the engine are suspect.

Self-Diagnosis

Backups

Backups

○The ECU takes the following measures to prevent engine damage when the DFI or the ignition system parts have troubles.

| Service Codes | Parts | Output Signal Usable Range or Criteria | Backups by ECU |
|---------------|--|--|--|
| 11 | Main Throttle Sensor | Main Throttle Sensor Output Voltage 0.20 V ~ 4.8 V | If the main throttle sensor system fails (the signal is out of the usable range, wiring short or open), the ECU locks ignition timing into the ignition timing at closed throttle position and sets the DFI in the D-J method. Also, the main throttle sensor system and inlet air pressure fails, the ECU locks ignition timing into the ignition timing at closed throttle position and sets the DFI in the α-N method. |
| 12 | Inlet Air Pressure Sensor | Inlet Air Pressure (absolute) Pv = 50 mmHg ~ 890 mmHg | If the inlet air pressure sensor system fails (the signal Pv is out of the usable range, wiring short or open), the ECU sets the DFI in the α - N method. |
| 13 | Inlet Air Temperature Sensor | Inlet Air Temperature Ta = -30°C ~ +120°C | If the inlet air temperature sensor fails (the signal is out of the usable range, wiring short or open), the ECU sets Ta at 40°C. |
| 14 | Water Temperature Sensor | Water Temperature Tw = -30°C ~ +120°C | If the water temperature sensor system fails (the signal is out of the usable range, wiring short or open), the ECU sets Tw at 80°C. |
| 21 | Crankshaft Sensor | Crankshaft sensor must send 17 signals (output signal) to the ECU at the one cranking. | If crankshaft sensor generates other than 17 signals, the engine stops by itself. |
| 24 and 25 | Speed Sensor | Speed sensor must send 26 signals (output signal) to the ECU at the one rotation of the transmission gear. The gear position is decided by the signal of the speed sensor. | If the speed sensor system fails (no signal, wiring short or open), the speedometer shows 0, and the ECU sets the top (5) gear position. |
| 31 | Vehicle-down Sensor | Vehicle-down Sensor Output Voltage (signal) Vd = 0.65 V ~ 4.45 V | If the vehicle-down sensor system has failures (the output voltage Vd is more than usable range, wiring open), the ECU shuts off the fuel pump, the fuel injectors and the ignition system. |
| 32 | Subthrottle Sensor | Subthrottle Sensor Output Voltage 0.15 V ~ 4.85 V | If the subthrottle sensor system fails (the signal is out of the usable range, wiring short or open), the actuator locks subthrottle valve at full open position. |
| 33 | Oxygen Sensor #1 (Oxygen Sensor Equipped Models) | The oxygen sensor is active and sensor must send signals (output voltage) continuously to the ECU. | If the oxygen sensor is not activated, the ECU stops oxygen sensor feedback mode. |

3-50 FUEL SYSTEM (DFI)

Self-Diagnosis

| Service Codes | Parts | Output Signal Usable Range or Criteria | Backups by ECU |
|---------------|---|--|---|
| 51 | Ignition Coil #1* | The ignition coil primary winding must send signals (output voltage) continuously to the ECU. | If the ignition primary winding #1 has failures (no signal, wiring short or open), the ECU shuts off the injector #1 to stop fuel to the cylinder #1, though the engine keeps running. |
| 52 | Ignition Coil #2* | The ignition coil primary winding must send signals (output voltage) continuously to the ECU. | If the ignition primary winding #2 has failures (no signal, wiring short or open), the ECU shuts off the injector #2 to stop fuel to the cylinder #2, though the engine keeps running. |
| 62 | Subthrottle Valve Actuator | The actuator operates open and close of the subthrottle valve by the pulse signal from the ECU. | If the subthrottle valve actuator fails (the signal is out of the usable range, wiring short or open), the ECU stops the current to the actuator. |
| 64 | Air Switching Valve | The air switching valve solenoid opens and shuts the air switching valve according to the signal from the ECU. | (Oxygen Sensor Equipped Models) When air switching valve solenoid does not operate, ECU ends the oxygen sensor feedback mode. (Without Oxygen Sensor Equipped Models) ECU does not backup. |
| 67 | Oxygen Sensor #1 (Oxygen Sensor Equipped Models) | The oxygen sensor heater raise temperature of the sensor for its earlier activation. 12 V-36 W, 1.5 A | If the oxygen sensor heater fails (wiring short or open), the ECU stops the current to the heater. |
| 83 | Oxygen Sensor #2 (Oxygen Sensor Equipped Models) | The oxygen sensor is active and sensor must send signals (output voltage) continuously to the ECU. | If the oxygen sensor is not activated, the ECU stops oxygen sensor feedback mode. |
| 94 | Oxygen Sensor #1 (Oxygen Sensor Equipped Models) | The oxygen sensor must send signals (output voltage) continuously to the ECU | If the oxygen sensor output voltage is incorrect, the ECU stops oxygen sensor feedback mode. |
| 95 | Oxygen Sensor #2 (Oxygen Sensor Equipped Models) | The oxygen sensor must send signals (output voltage) continuously to the ECU | If the oxygen sensor output voltage is incorrect, the ECU stops oxygen sensor feedback mode. |

Note:

(1) D-J Method and α - N Method: When the engine load is light like at idling or low speed, the ECU determines the injection quantity by calculating from the throttle vacuum (inlet air pressure sensor output voltage) and engine speed (crankshaft sensor output voltage). This method is called D-J method (low-speed mode). As the engine speed increases, and the engine load turns middle to heavy, the ECU determines the injection quantity by calculating from the throttle opening (throttle sensor output voltage) and the engine speed. This method is called α - N method (high-speed mode).

(*) This depends on the number of stopped cylinders.

Main Throttle Sensor (Service Code 11)

The main throttle sensor is a rotating variable resistor that change output voltage according to throttle operating. The ECU senses this voltage change and determines fuel injection quantity, and ignition timing according to engine rpm, and throttle opening.

- Input Terminal [A]
- Output Terminal [B]
- Ground Terminal [C]

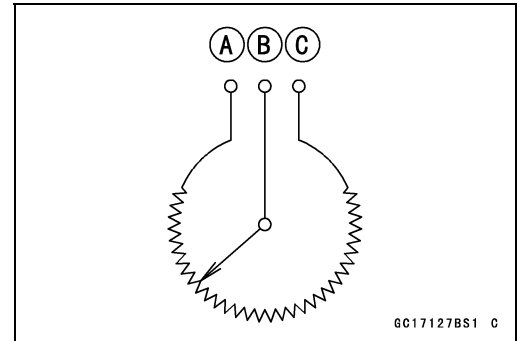

Main Throttle Sensor Removal/Adjustment

| NOTICE |
|---|
| <p>Do not remove or adjust the main throttle sensor [A] since it has been adjusted and set with precision at the factory.</p> <p>Never drop the throttle body assy, especially on a hard surface. Such a shock to the sensor can damage it.</p> |

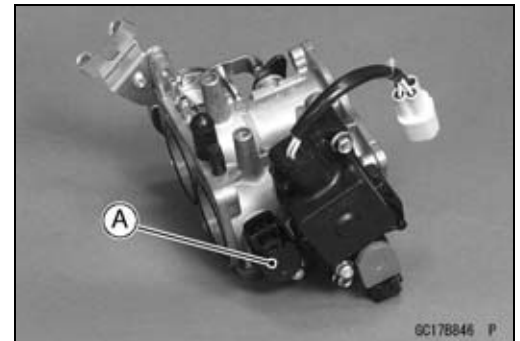

Main Throttle Sensor Input Voltage Inspection

NOTE

○Be sure the battery is fully charged.

- Turn the ignition switch OFF.
- Remove the ECU (see ECU Removal). Do not disconnect the ECU connectors.
- Connect a digital voltmeter to the connector, using the needle adapter set.

Special Tool - Needle Adapter Set: 57001-1457

Main Throttle Sensor Input Voltage Connections to ECU Connector

(Without Oxygen Sensor Equipped Models [A])

- Meter (+) → BL lead (terminal 8)
- Meter (-) → BR/BK lead (terminal 22)

(Oxygen Sensor Equipped Models [B])

- Meter (+) → BL lead (terminal 10)
- Meter (-) → BR/BK lead (terminal 28)

- Measure the input voltage with the engine stopped, and with the connectors joined.
- Turn the ignition switch ON.

Input Voltage at ECU Connector
Standard: DC 4.75 ~ 5.25 V

- Turn the ignition switch OFF.
- ★ If the reading of input voltage is less than the standard, check the ECU for its ground, power supply and wiring shorted (see ECU Power Supply Inspection).
- ★ If the input voltage is within the standard range remove the fuel tank, and check wiring from ECU to the main throttle sensor for continuity.
- ★ If the wiring is good, check the output voltage of the main throttle sensor.

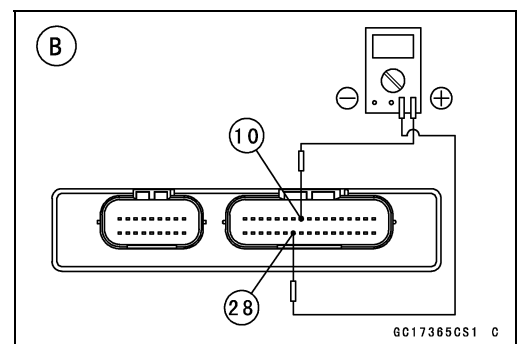
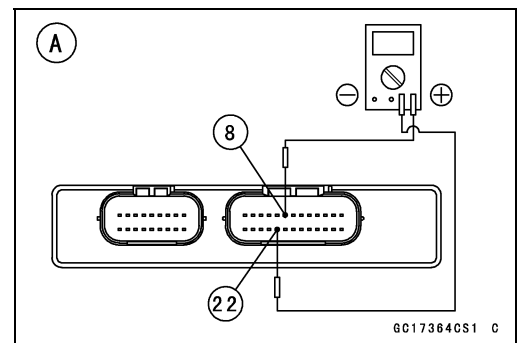

3-52 FUEL SYSTEM (DFI)

Main Throttle Sensor (Service Code 11)

Main Throttle Sensor Output Voltage Inspection

- Measure the output voltage at the ECU in the same way as input voltage inspection.

Special Tool - Needle Adapter Set: 57001-1457

Main Throttle Sensor Output Voltage Connections to ECU

(Without Oxygen Sensor Equipped Models [A])

Meter (+) → Y/W lead (terminal 6)

Meter (-) → BR/BK lead (terminal 22)

(Oxygen Sensor Equipped Models [B])

Meter (+) → Y/W lead (terminal 7)

Meter (-) → BR/BK lead (terminal 28)

- Start the engine and warm it up thoroughly.
- Check idle speed to ensure throttle opening is correct.

Idle Speed

Standard: 1 000 ±50 r/min (rpm)

- ★ If the idle speed is out of the specified range, adjust it (see Idle Speed Inspection in the Periodic Maintenance chapter).

- Turn the ignition switch OFF.
- Measure the output voltage with the engine stopped, and with the connector joined.
- Turn the ignition switch ON.
- Measure the output voltage when the throttle is fully opened or completely closed.

Output Voltage at ECU

Standard: DC 1.05 ~ 4.26 V (at idle throttle opening to full throttle opening)

NOTE

- The main throttle sensor is operating correctly if the following voltages are obtained.
 - DC 1.05 V (or slightly higher) with the throttle at the idle position.
 - DC 4.26 V (or slightly lower) with the throttle at the fully open position.

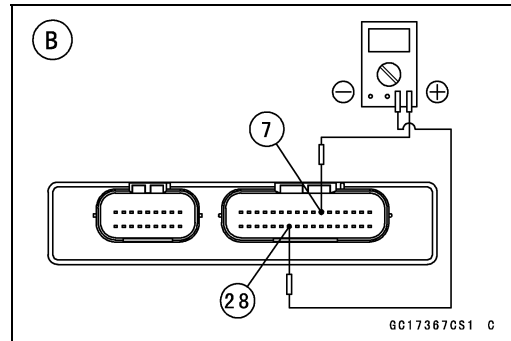
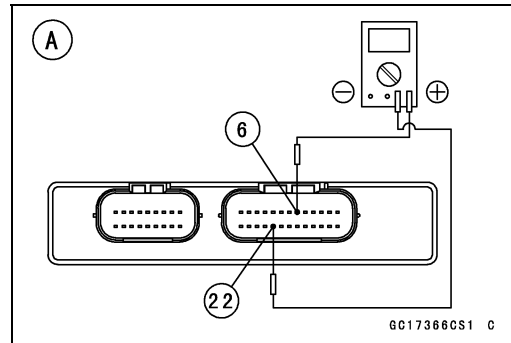

NOTICE

Do not remove or adjust the main throttle sensor since it has been adjusted and set with precision at the factory.

Never drop the throttle body assy, can especially on a hard surface. Such a shock to the sensor can damage it.

Main Throttle Sensor (Service Code 11)

NOTE

- The standard voltage marked with an asterisk refers to the value when the voltage reading at the Input Voltage Inspection shows 5 V exactly.
- When the input voltage reading shows other than 5 V, derive a voltage range as follows.

Example:

In the case of a input voltage of 4.75 V.

$$1.05 \times 4.75 \div 5.00 = 1.00 \text{ V}$$

$$4.26 \times 4.75 \div 5.00 = 4.05 \text{ V}$$

Thus, the valid range is 1.00 ~ 4.05 V

- ★ If the output voltage is within the standard range, check the wiring for continuity (see next diagram).
- ★ If the output voltage is far out of the standard range (e.g. when the wiring is open, the reading is 0 V), check the main throttle sensor resistance.

Main Throttle Sensor Resistance Inspection

- Turn the ignition switch OFF.
- Disconnect the main throttle sensor connector.
- Connect a digital meter [A] to the main throttle sensor connector [B].
- Measure the main throttle sensor resistance.

Main Throttle Sensor Resistance

Connections: BL lead [C] ↔ BR/BK lead [D]

Standard: 4 ~ 6 kΩ

- ★ If the reading is out of the range, replace the throttle body assy.
- ★ If the reading is within the range, but the problem still exists, replace the ECU.

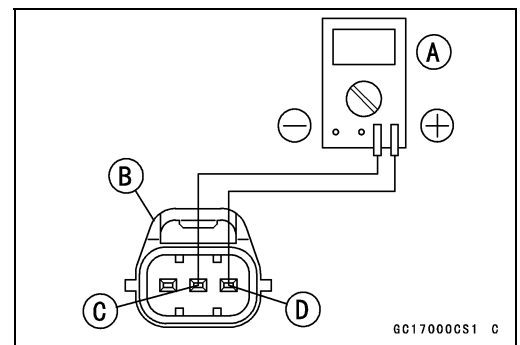

3-54 FUEL SYSTEM (DFI)

Main Throttle Sensor (Service Code 11)

Main Throttle Sensor Circuit (Without Oxygen Sensor Equipped Models)

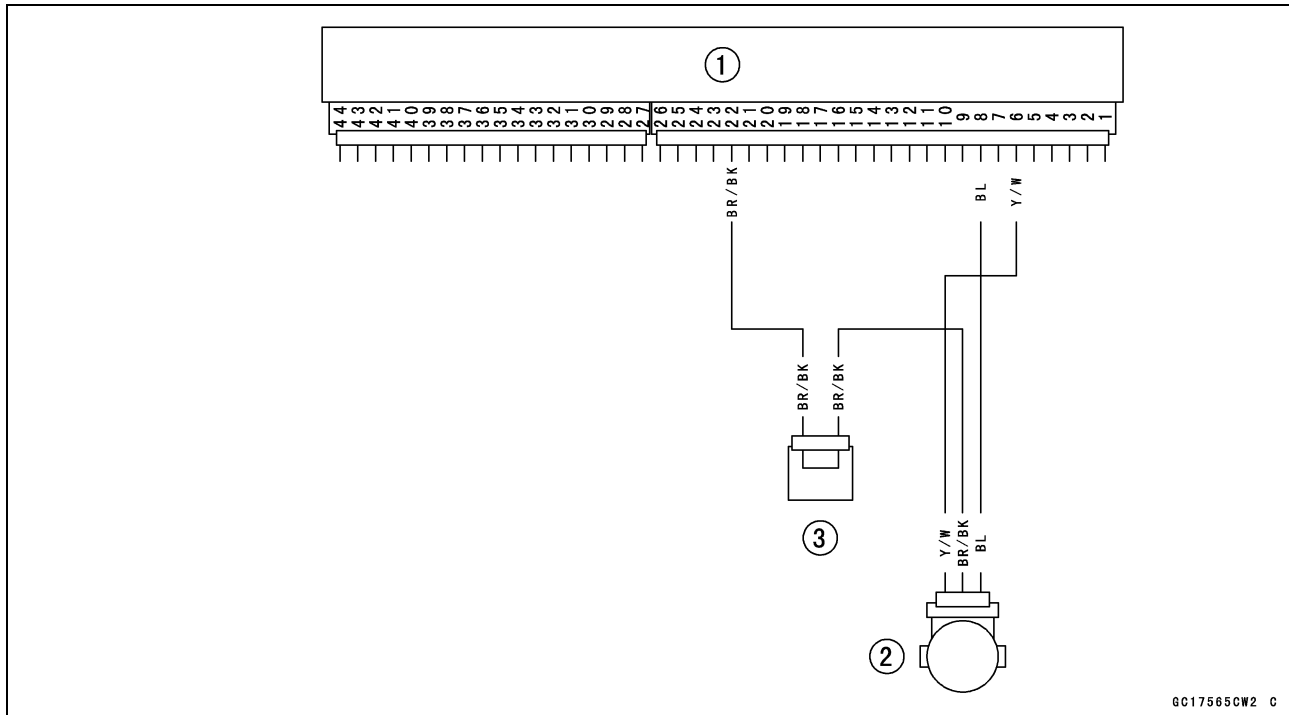

Main Throttle Sensor Circuit (Oxygen Sensor Equipped Models)

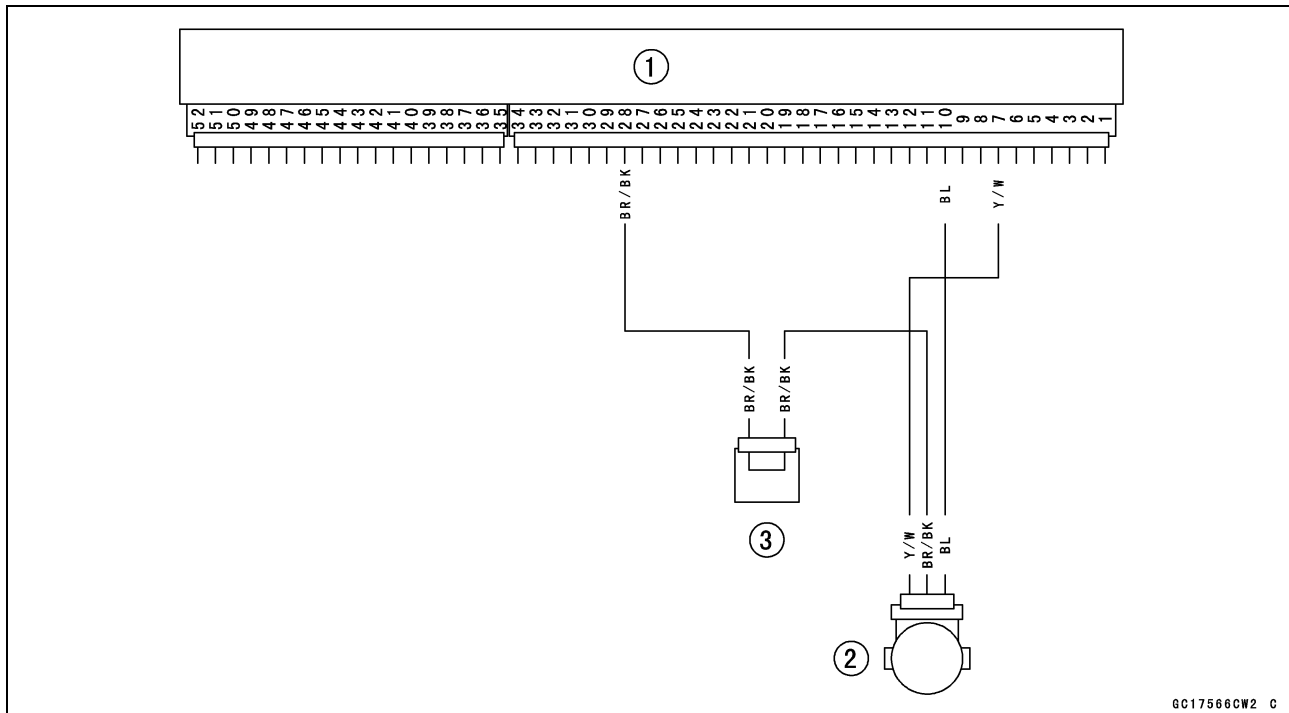

- 1. ECU
- 2. Main Throttle Sensor
- 3. Joint Connector B

Inlet Air Pressure Sensor (Service Code 12)

Inlet Air Pressure Sensor Removal

NOTICE

Never drop the sensor, especially on a hard surface. Such a shock to the part can damage it.

- Remove:
 - Fuel Tank (see Fuel Tank Removal)
 - Bolt [A]
- Disconnect the inlet air pressure sensor connector [B], and remove the sensor [C].
- Disconnect the vacuum hose [D] from the sensor.

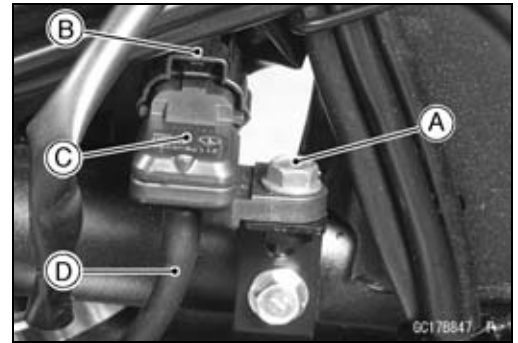

Inlet Air Pressure Sensor Installation

- Connect the inlet air pressure sensor connector [A].
- Route the vacuum hose correctly (see Cable, Wire, and Hose Routing section in the Appendix chapter). Make sure it doesn't get pinched or kinked.
- Install the inlet air pressure sensor [B].
- The stopper [C] must not be on the sensor holder [D].
- Tighten:
 - Torque - Inlet Air Pressure Sensor Bolt: 6.9 N·m (0.70 kgf·m, 61 in·lb)**
- Install the fuel tank (see Fuel Tank Installation).

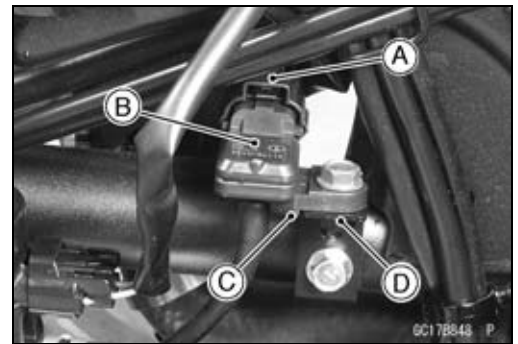

Inlet Air Pressure Sensor Input Voltage Inspection

NOTE

- Be sure the battery is fully charged.
- The inspection is the same as "Input Voltage Inspection" of the main throttle sensor and the atmospheric pressure sensor.

- Turn the ignition switch OFF.
- Remove the ECU (see ECU Removal). Do not disconnect the ECU connectors.
- Connect a digital voltmeter to the connector, using the needle adapter set.

Special Tool - Needle Adapter Set: 57001-1457

Inlet Air Pressure Sensor Input Voltage Connections to ECU

(Without Oxygen Sensor Equipped Models [A])

- Meter (+) → BL lead (terminal 8)
- Meter (-) → BR/BK lead (terminal 22)

(Oxygen Sensor Equipped Models [B])

- Meter (+) → BL lead (terminal 10)
- Meter (-) → BR/BK lead (terminal 28)

- Measure the input voltage with the engine stopped, and with the connectors joined.
- Turn the ignition switch ON.

Input Voltage at ECU
Standard: DC 4.75 ~ 5.25 V

- ★ If the reading is less than the standard range, check the ECU for its ground, and power supply and wiring shorted (see ECU Power Supply Inspection). If the ground and power supply are good, replace the ECU.

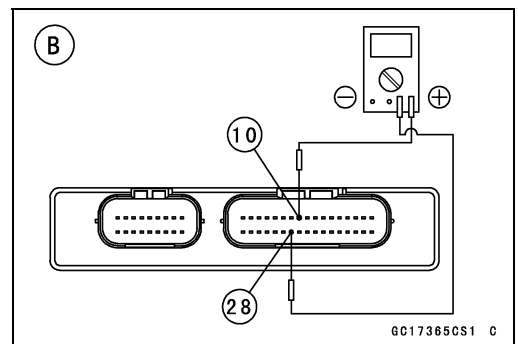
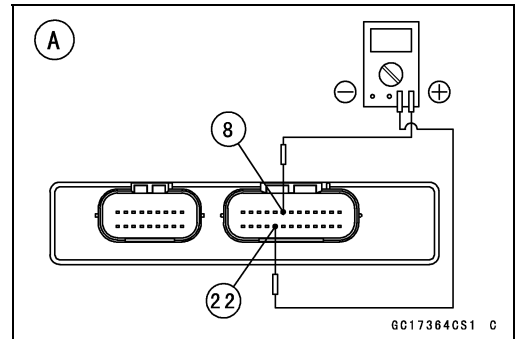

3-56 FUEL SYSTEM (DFI)

Inlet Air Pressure Sensor (Service Code 12)

- ★ If the reading is within the standard range, remove the fuel tank, and check wiring from ECU to the inlet pressure sensor for continuity.
- ★ If wiring is good, check the output voltage of the inlet air pressure sensor.

Inlet Air Pressure Sensor Output Voltage Inspection

- Measure the output voltage at the ECU in the same way as input voltage inspection. Note the following.

Inlet Air Pressure Sensor Output Voltage Connections to ECU

(Without Oxygen Sensor Equipped Models [A])

Meter (+) → Y/BL lead (terminal 7)

Meter (-) → BR/BK lead (terminal 22)

(Oxygen Sensor Equipped Models [B])

Meter (+) → Y/BL lead (terminal 8)

Meter (-) → BR/BK lead (terminal 28)

Output Voltage at ECU

Usable Range: DC 3.80 ~ 4.20 V at the standard atmospheric pressure (101.32 kPa, 76 cmHg abs.)

NOTE

- The output voltage changes according to the local atmospheric pressure.
 - The inlet air pressure sensor output voltage is based on a nearly perfect vacuum in the small chamber of the sensor. So, the sensor indicates absolute vacuum pressure.
- ★ If the output voltage is out of the usable range, replace the sensor.
 - ★ If the output voltage is normal, check the inlet air pressure sensor for vacuum other than 76 cmHg (abs.), check the output voltage as follows.

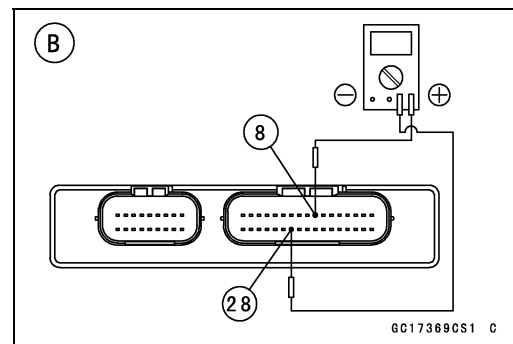
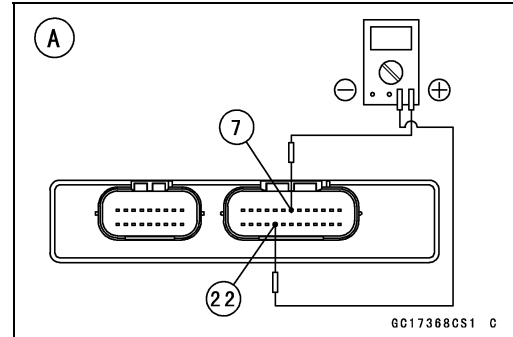

Inlet Air Pressure Sensor (Service Code 12)

- Remove the inlet air pressure sensor [A] and disconnect the vacuum hose from the sensor.
- Do not disconnect the sensor connector.
- Connect an auxiliary hose [B] to the inlet air pressure sensor.
- Temporarily install the inlet air pressure sensor.
- Connect a commercially available digital meter [C], vacuum gauge [D], and the fork oil level gauge [E] to the inlet air pressure sensor.

Special Tool - Fork Oil Level Gauge: 57001-1290

Inlet Air Pressure Sensor Output Voltage Connection to Sensor

Meter (+) → Y/BL lead

Meter (-) → BR/BK lead

- Turn the ignition switch ON.
- Measure the inlet air pressure sensor output voltage from various vacuum readings, while pulling the handle of the fork oil level gauge.
- Check the inlet air pressure sensor output voltage, using the following formula and chart.

Suppose

Pg: Vacuum Pressure (gauge) of Throttle Assy

PI: Local Atmospheric Pressure (absolute) measured by a barometer

Pv: Vacuum Pressure (absolute) of Throttle Assy

Vv: Sensor Output Voltage (V)

then

$$Pv = PI - Pg$$

For example, suppose the following data is obtained:

Pg = 8 cmHg (vacuum gauge reading)

PI = 70 cmHg (barometer reading)

Vv = 3.2 V (digital volt meter reading)

then

$$Pv = 70 - 8 = 62 \text{ cmHg (abs.)}$$

Plot this Pv (62 cmHg) at a point [1] on the chart and draw a vertical line through the point. Then, you can get the usable range [2] of the sensor output voltage.

Usable range = 3.08 ~ 3.48 V

Plot Vv (3.2 V) on the vertical line. → Point [3].

Results: In the chart, Vv is within the usable range and the sensor is normal.

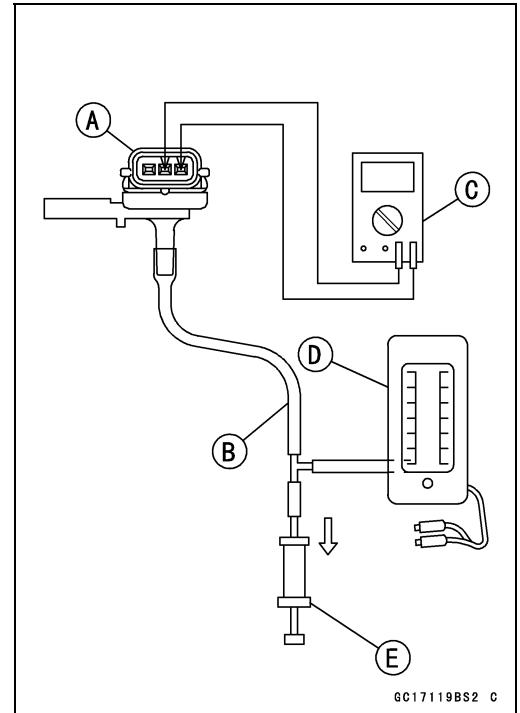

GG17119BS2 C

3-58 FUEL SYSTEM (DFI)

Inlet Air Pressure Sensor (Service Code 12)

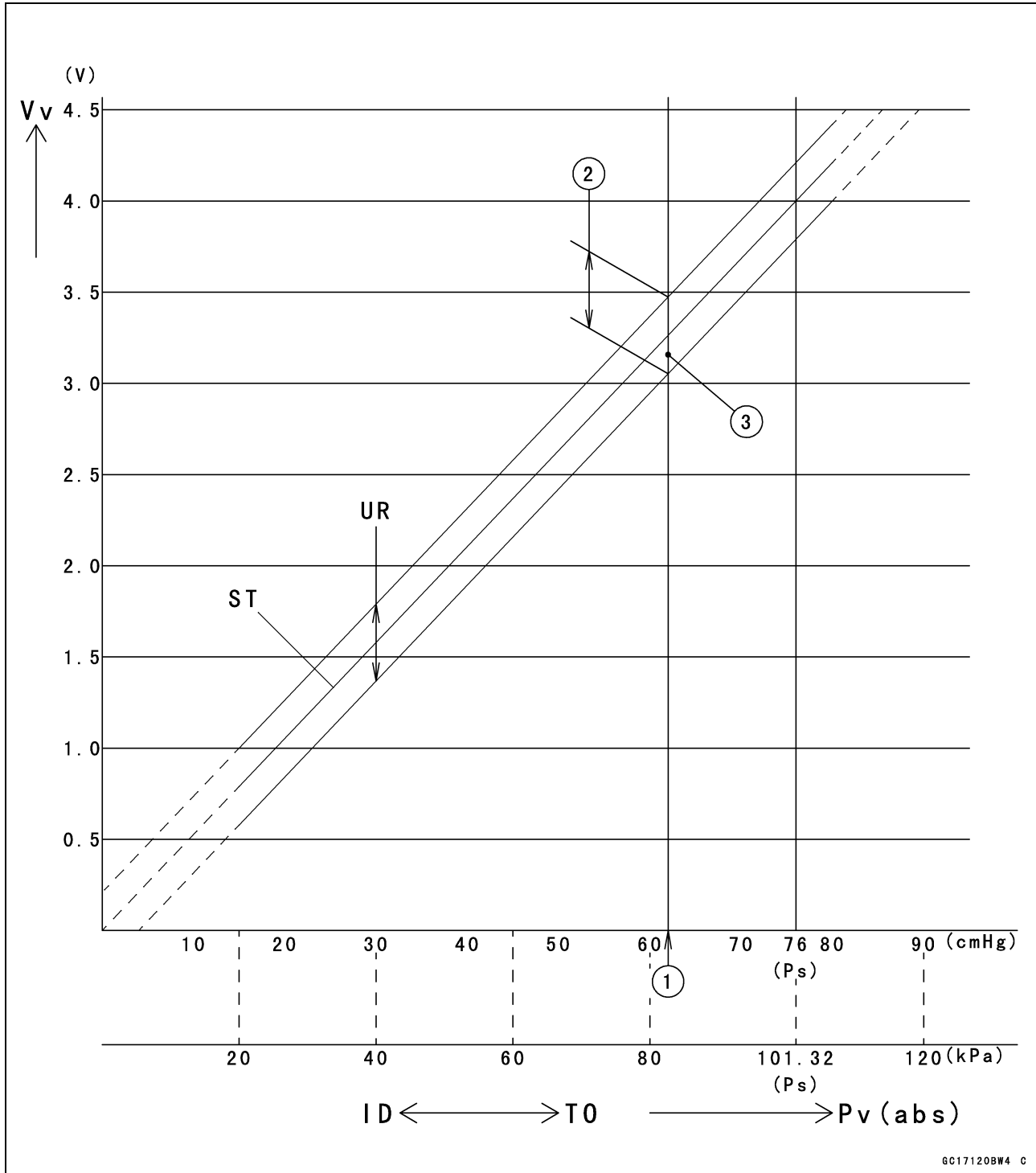

- ID: Idling
- Ps: Standard Atmospheric Pressure (Absolute)
- Pv: Throttle Vacuum Pressure (Absolute)
- ST: Standard of Sensor Output Voltage (V)
- TO: Throttle Full Open
- UR: Usable Range of Sensor Output Voltage (V)
- Vv: Inlet Air Pressure Sensor Output Voltage (V) (Digital Meter Reading)

Inlet Air Pressure Sensor (Service Code 12)

Inlet Air Pressure Sensor Circuit (Without Oxygen Sensor Equipped Models)

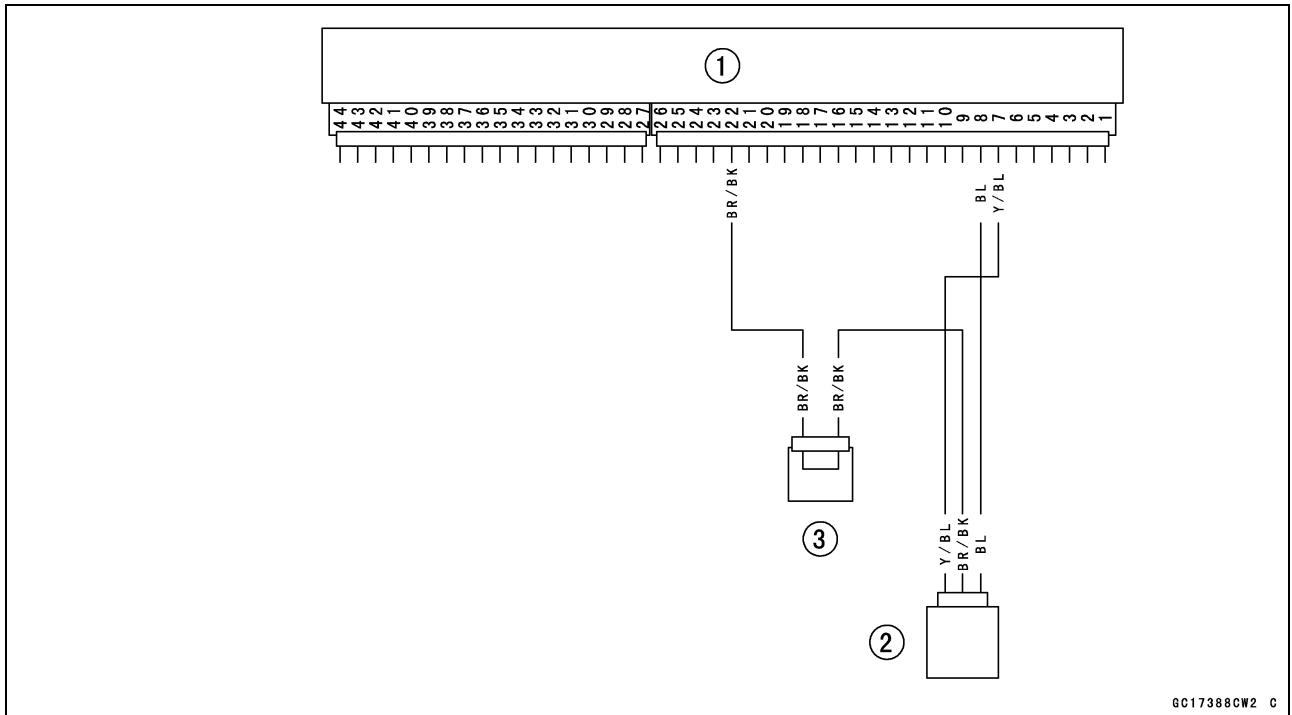

Inlet Air Pressure Sensor Circuit (Oxygen Sensor Equipped Models)

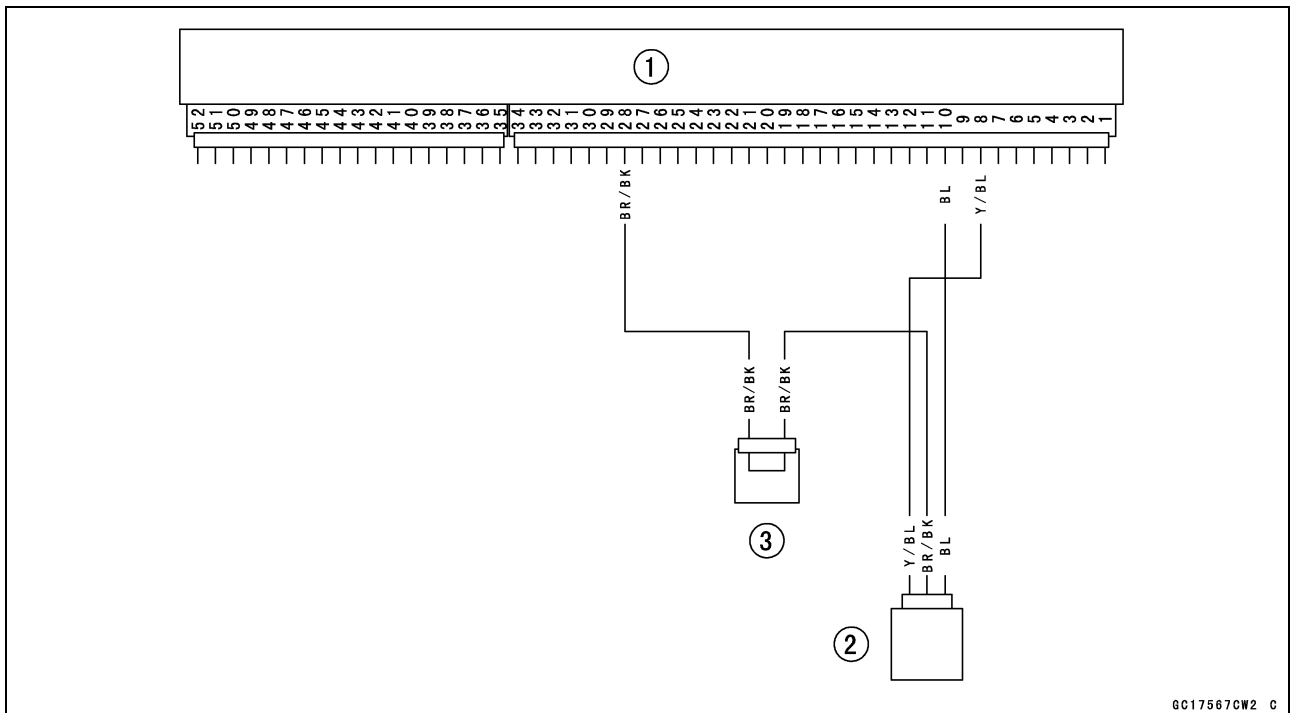

- 1. ECU
- 2. Inlet Air Pressure Sensor
- 3. Joint Connector B

3-60 FUEL SYSTEM (DFI)

Inlet Air Temperature Sensor (Service Code 13)

Inlet Air Temperature Sensor Removal/Installation

NOTICE

Never drop the sensor, especially on a hard surface. Such a shock to the sensor can damage it.

- Remove the air cleaner housing (see Air Cleaner Housing Removal).
- Remove the screw [A].
- Pull out the inlet air temperature sensor [B] out of the air cleaner housing.
- Put the inlet air temperature sensor into the air cleaner housing.
- Tighten:

Torque - Inlet Air Temperature Sensor Screw: 1.2 N·m (0.12 kgf·m, 11 in·lb)

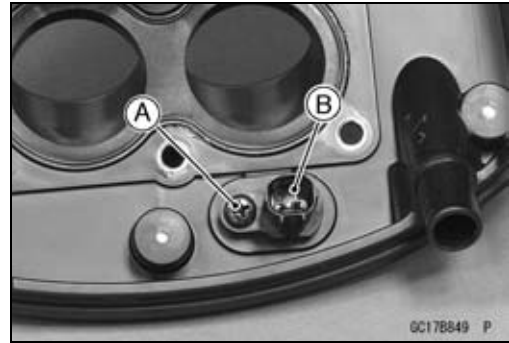

Inlet Air Temperature Sensor Output Voltage Inspection

NOTE

○ Be sure the battery is fully charged.

- Remove the ECU (see ECU Removal). Do not disconnect the ECU connectors.
- Connect a digital voltmeter to the ECU connector, using needle adapter set.

Special Tool - Needle Adapter Set: 57001-1457

Inlet Air Temperature Sensor Output Voltage Connections to ECU Connector

(Without Oxygen Sensor Equipped Models [A])

Meter (+) → Y lead (terminal 20)

Meter (-) → BR/BK lead (terminal 22)

(Oxygen Sensor Equipped Models [B])

Meter (+) → Y lead (terminal 26)

Meter (-) → BR/BK lead (terminal 28)

- Measure the sensor output voltage with the engine stopped and the connector joined.
- Turn the ignition switch ON.

Output Voltage at ECU

Standard: About 2.25 ~ 2.50 V at inlet air temperature 20°C (68°F)

NOTE

○ The output voltage changes according to the inlet air temperature.

- Turn the ignition switch OFF.
- ★ If the output voltage is out of the specified, check the ECU for its ground, and power supply (see ECU Power Supply Inspection). If the ground and power supply are good, remove the air cleaner housing, check the wiring between the ECU and the inlet air temperature sensor.
- ★ If the wiring is good, check the sensor resistance.

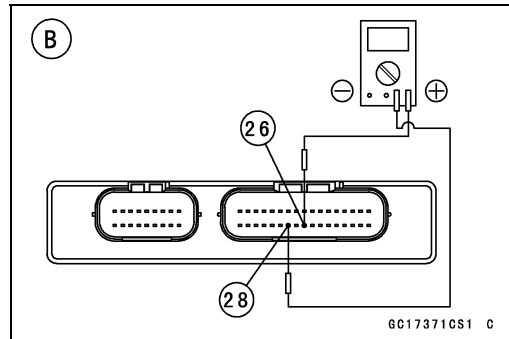
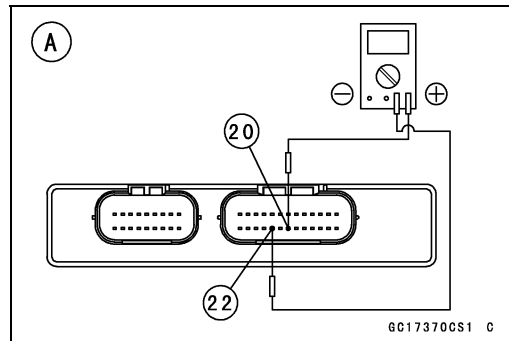

Inlet Air Temperature Sensor (Service Code 13)

Inlet Air Temperature Sensor Resistance Inspection

- Remove the inlet air temperature sensor (see Inlet Air Temperature Sensor Removal).
- Suspend the sensor [A] in a container of machine oil so that the heat-sensitive portion is submerged.
- Suspend a thermometer [B] with the heat-sensitive portion [C] located in almost the same depth with the sensor.

NOTE

○ *The sensor and thermometer must not touch the container side or bottom.*

- Place the container over a source of heat and gradually raise the temperature of the oil while stirring the oil gently for even temperature.
- Using a digital meter, measure the internal resistance of the sensor across the terminals at the temperatures shown in the table.

Inlet Air Temperature Sensor Resistance

Standard: 5.4 ~ 6.6 kΩ at 0°C (32°F)

0.29 ~ 0.39 kΩ at 80°C (176°F)

- ★ If the measurement is out of the range, replace the sensor.
- ★ If the measurement is within the specified, replace the ECU.

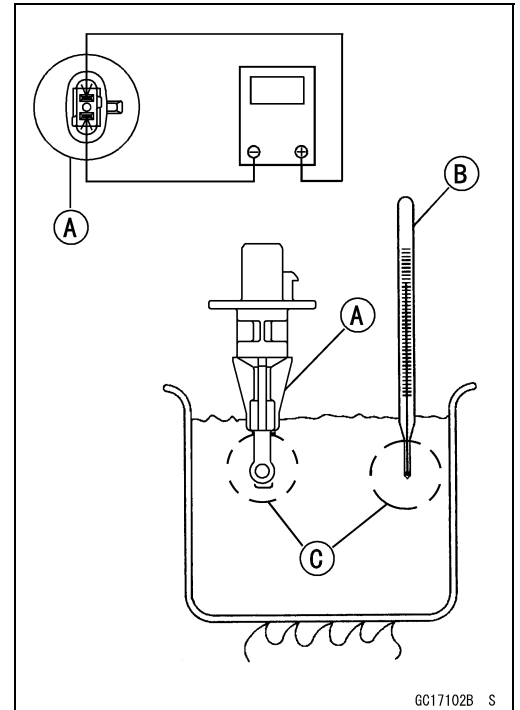

3-62 FUEL SYSTEM (DFI)

Inlet Air Temperature Sensor (Service Code 13)

Inlet Air Temperature Sensor Circuit (Without Oxygen Sensor Equipped Models)

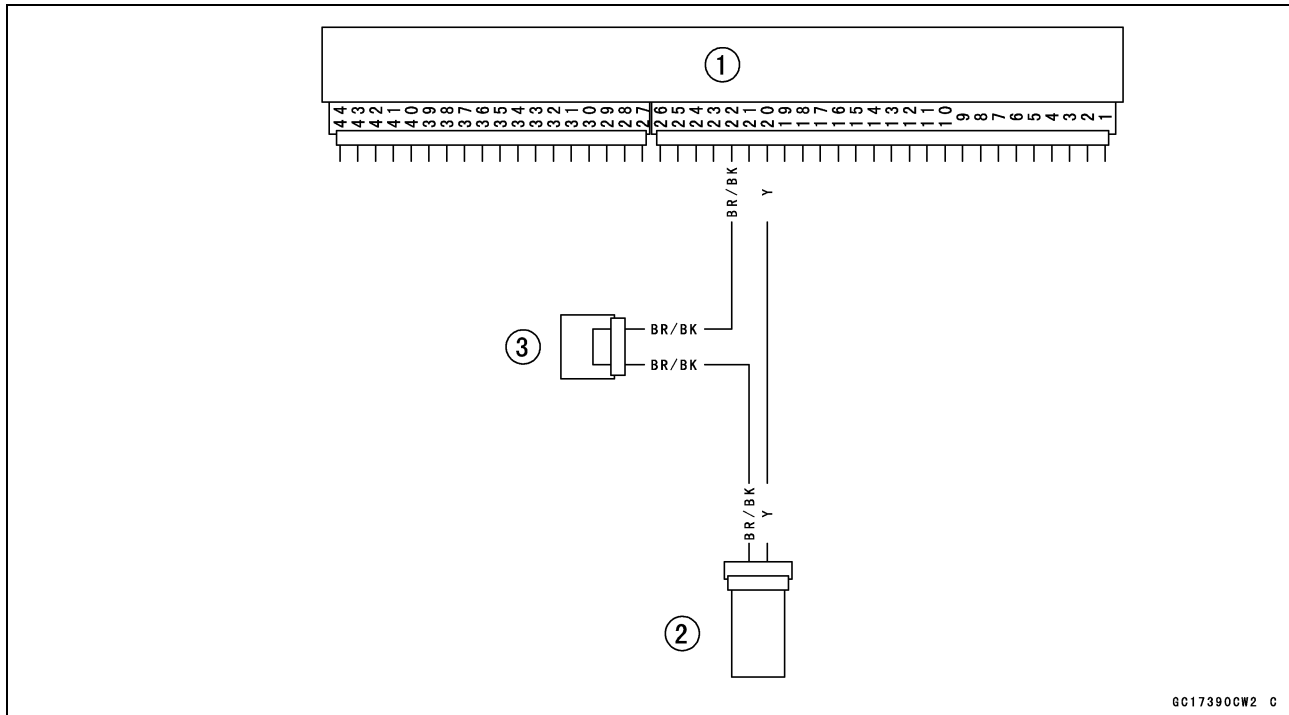

Inlet Air Temperature Sensor Circuit (Oxygen Sensor Equipped Models)

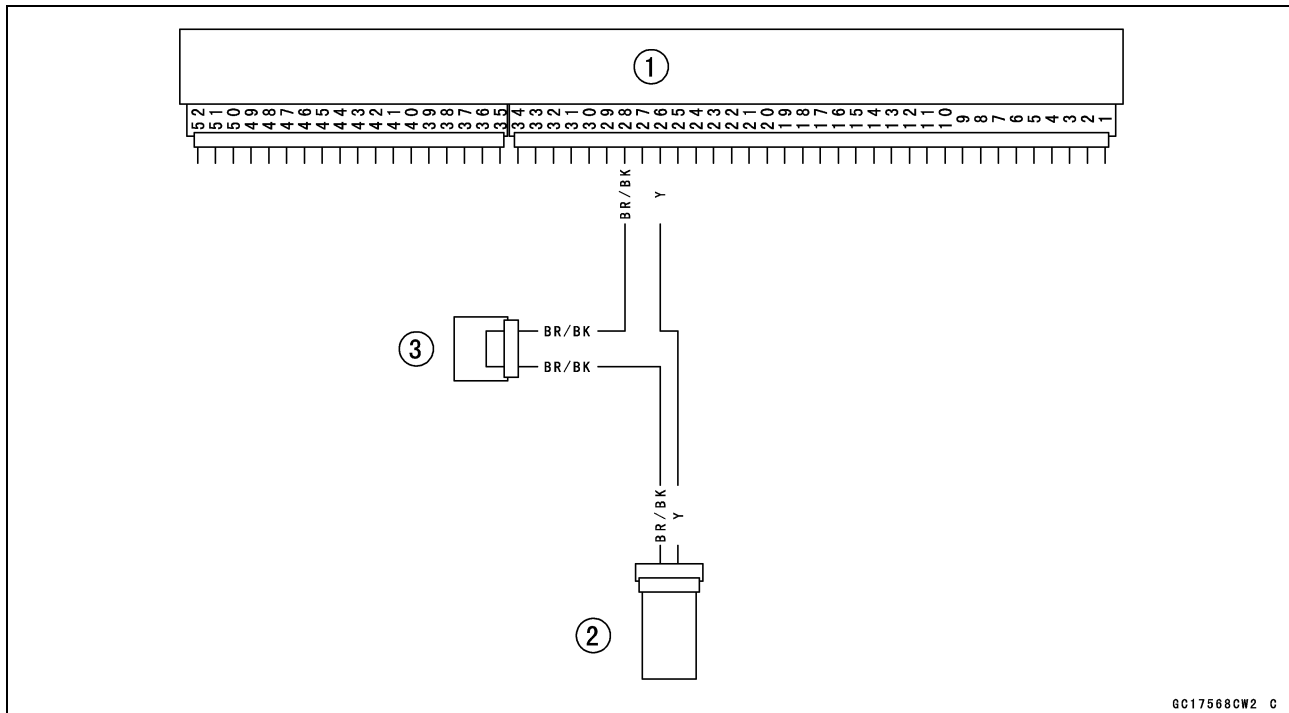

- 1. ECU
- 2. Inlet Air Temperature Sensor
- 3. Joint Connector B

Water Temperature Sensor (Service Code 14)

Water Temperature Sensor Removal/Installation

NOTICE

Never drop the sensor, especially on a hard surface. Such a shock to the sensor can damage it.

- Remove the fuel tank (see Fuel Tank Removal).
- Drain the coolant (see Coolant Change in the Periodic Maintenance chapter).
- Disconnect the sensor connector [A], and unscrew the water temperature sensor [B].
- Tighten:

Torque - Water Temperature Sensor: 12 N·m (1.2 kgf·m, 106 in·lb)

- Fill the engine with coolant and bleed the air from the cooling system (see Coolant Change in the Periodic Maintenance chapter).



Water Temperature Sensor Output Voltage Inspection

NOTE

- Be sure the battery is fully charged.
- The output voltage changes according to the coolant temperature in the engine.

- Remove the ECU (see ECU Removal). Do not disconnect the connectors.
- Connect a digital voltmeter to the ECU connector, using the needle adapter set.

Special Tool - Needle Adapter Set: 57001-1457

- Measure the output voltage of the sensor with the engine stopped and the connector joined.
- Turn the ignition switch ON.

Water Temperature Sensor Output Voltage Connections to ECU

(Without Oxygen Sensor Equipped Models [A])

- Meter (+) → O lead (terminal 17)**
- Meter (-) → BR/BK lead (terminal 22)**

(Oxygen Sensor Equipped Models [B])

- Meter (+) → O lead (terminal 20)**
- Meter (-) → BR/BK lead (terminal 28)**

Standard: About 2.80 ~ 2.97 V at 20°C (68°F)

- Turn the ignition switch OFF.
- ★ If the output voltage is out of the specified, check the ECU for its ground, and power supply (see ECU Power Supply Inspection). If the ground and power supply are good, remove the fuel tank and check the wiring between the ECU and the water temperature sensor for continuity.
- ★ If the wiring is good, check the water temperature sensor resistance.

Water Temperature Sensor Resistance Inspection

- Refer to the Water Temperature Sensor Inspection in the Electrical System chapter.

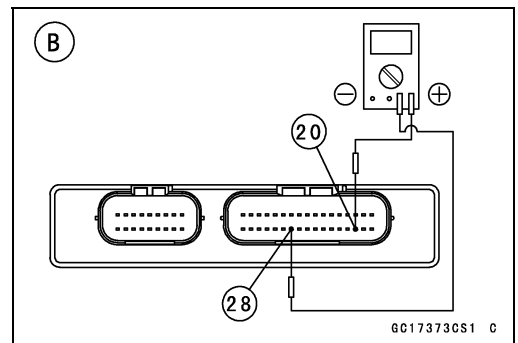
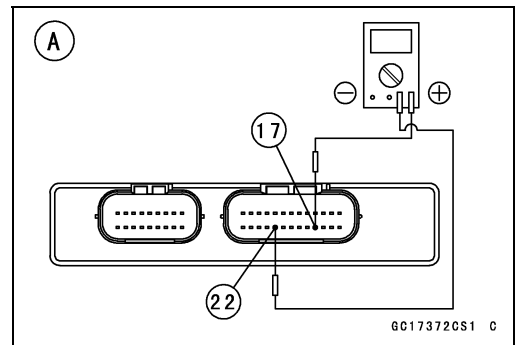

3-64 FUEL SYSTEM (DFI)

Water Temperature Sensor (Service Code 14)

Water Temperature Sensor Circuit (Without Oxygen Sensor Equipped Models)

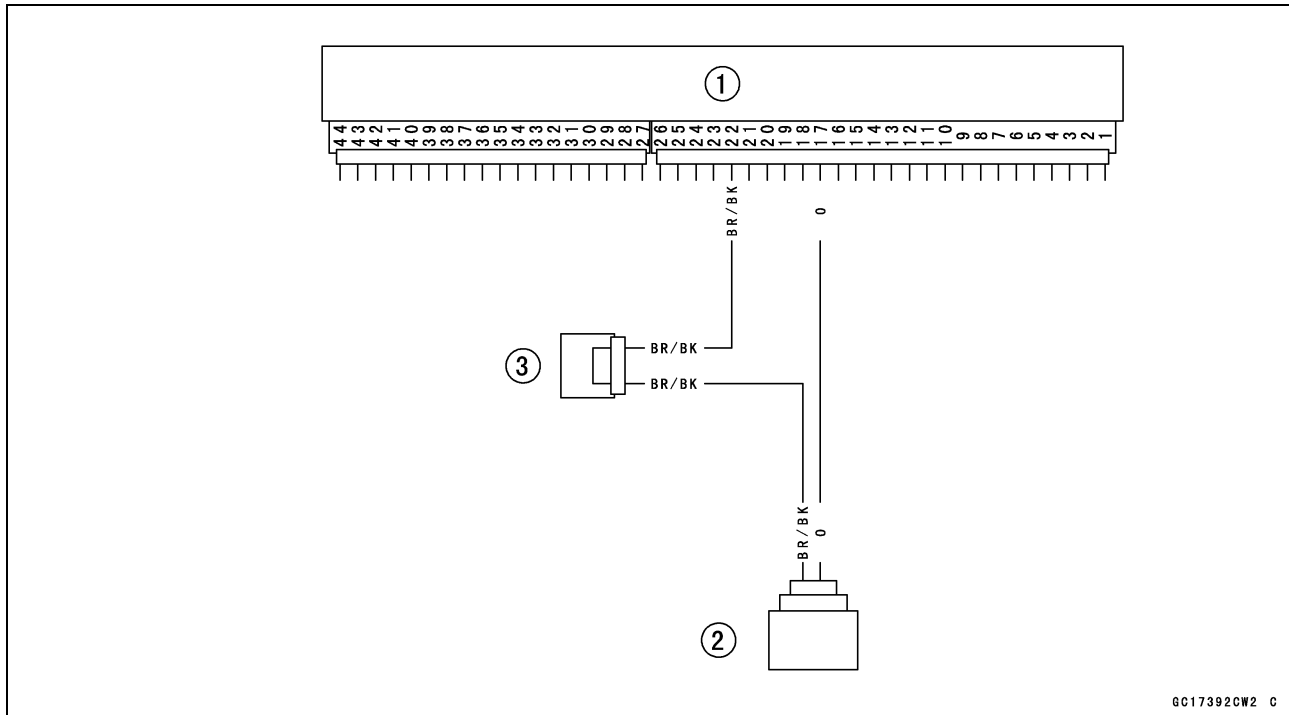

Water Temperature Sensor Circuit (Oxygen Sensor Equipped Models)

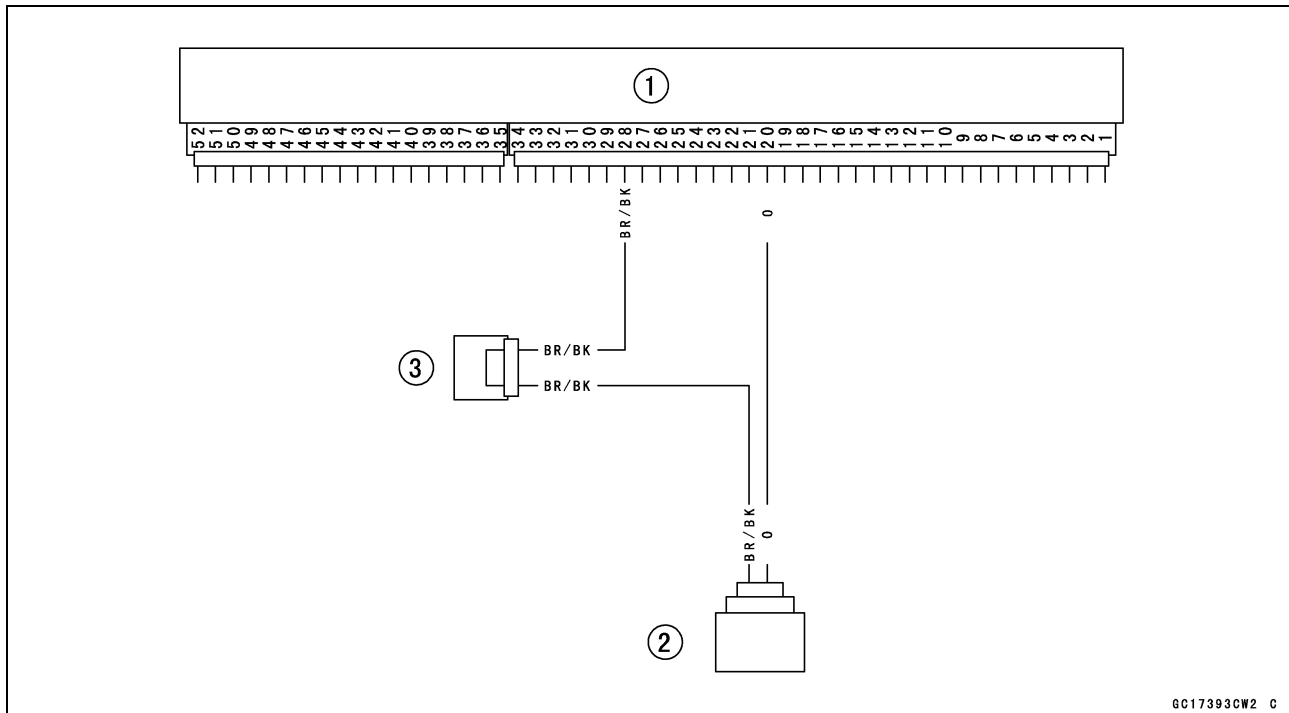

- 1. ECU
- 2. Water Temperature Sensor
- 3. Joint Connector B

Crankshaft Sensor (Service Code 21)

Start the engine and switch the diagnosis mode to Dealer 1 mode to know all the problem that the DFI system has at the time of self-diagnosis. If the engine cannot be started, the self-diagnosis system does not detect dynamic condition of the crankshaft sensor. In this case turn off the ignition switch and turn it on again to enter the Dealer 2 mode. In this mode the system tells all the troubles which the DFI system had in both static and dynamic conditions.

Crankshaft Sensor Removal/Installation

- Refer to the Crankshaft Sensor Removal and Installation in the Electrical System chapter.

Crankshaft Sensor Inspection

- The crankshaft has no power source, and when the engine stops, the crankshaft generates no signals.
- Crank the engine and measure the peak voltage of the crankshaft sensor (see Crankshaft Sensor Peak Voltage Inspection in the Electrical System chapter) in order to check the sensor.
- Check the wiring for continuity, using the following diagram.

3-66 FUEL SYSTEM (DFI)

Crankshaft Sensor (Service Code 21)

Crankshaft Sensor Circuit (Without Oxygen Sensor Equipped Models)

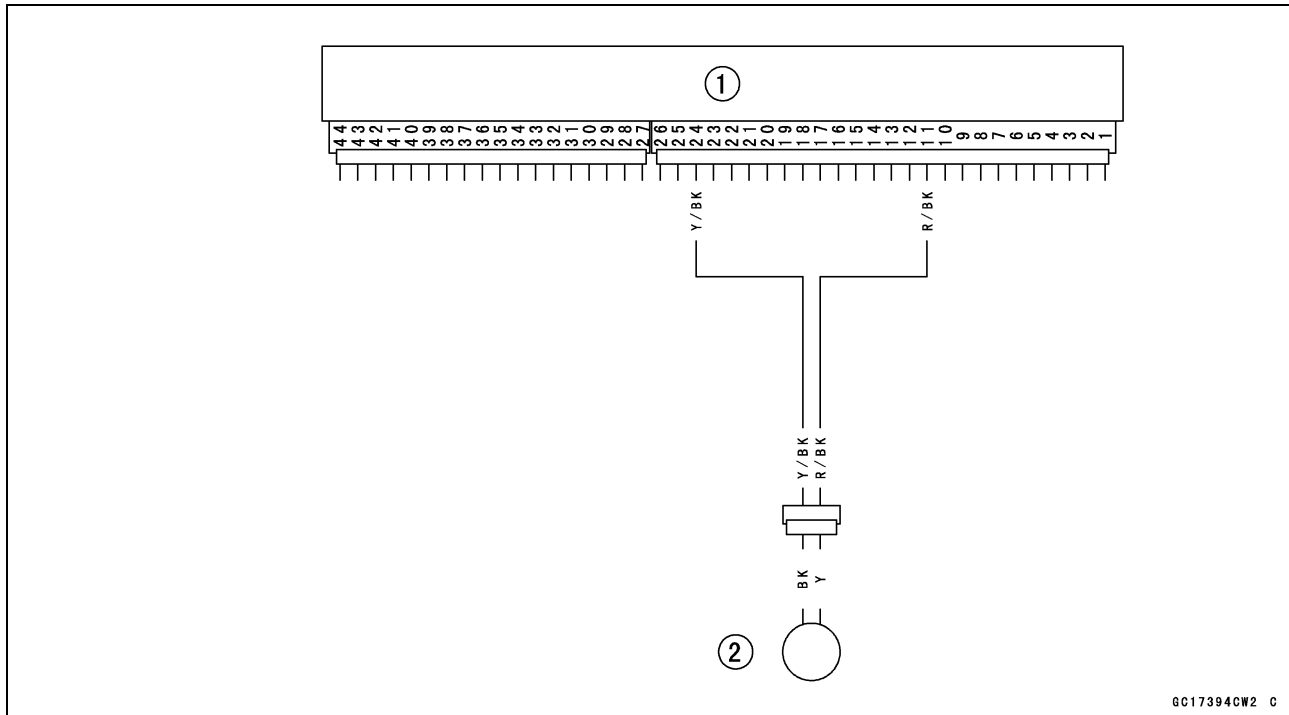

Crankshaft Sensor Circuit (Oxygen Sensor Equipped Models)

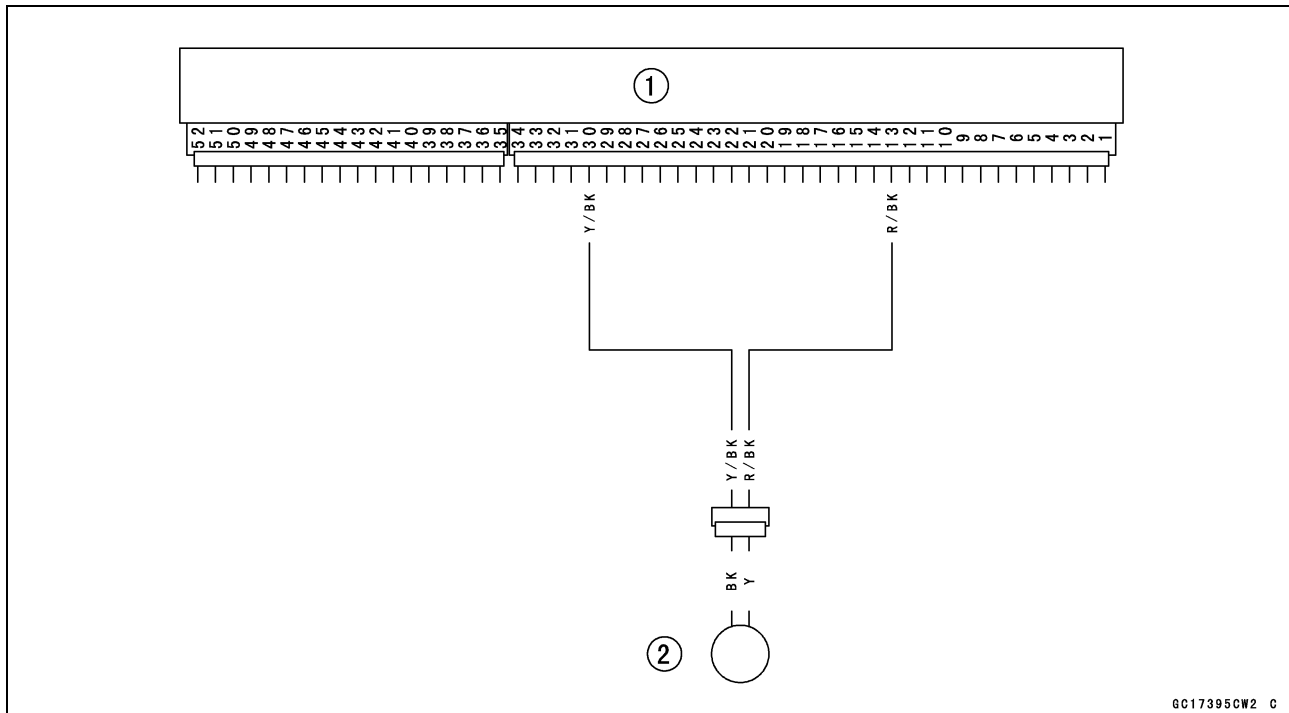

- 1. ECU
- 2. Crankshaft Sensor

Speed Sensor (Service Code 24, 25)

Speed Sensor Removal

- Refer to the Speed Sensor Removal in the Electrical System chapter.

Speed Sensor Installation

- Refer to the Speed Sensor Installation in the Electrical System chapter.

Speed Sensor Inspection

- Refer to the Speed Sensor Inspection in the Electrical System chapter.

Speed Sensor Input Voltage Inspection

NOTE

○ Be sure the battery is fully charged.

- Turn the ignition switch OFF.
 - Remove the speed sensor (see Speed Sensor Removal in the Electrical System chapter).
 - Connect the measuring adapter [A] between the harness connector [B] and speed sensor connector [C].
- Special Tool - Speed Sensor Measuring Adapter: 57001-1667**
- Reinstall the speed sensor with the measuring adapter connected.
 - Connect a digital meter [D] to the measuring adapter lead connectors.

Speed Sensor Input Voltage

Connections to Adapter

Meter (+) → BK/Y (sensor BL) lead

Meter (-) → BL (sensor BR/BK) lead

- Measure the input voltage with the engine stopped, and with the connectors joined.
- Turn the ignition switch ON.

Input Voltage at Sensor

Standard: DC 4.75 ~ 5.25 V

- ★ If the reading is out of the range, check the wiring.
- ★ If the reading is good, check the output voltage.
- Turn the ignition switch OFF.

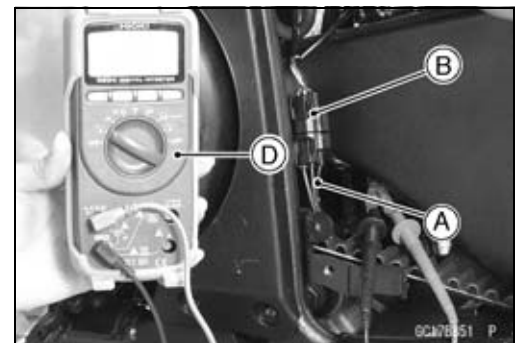
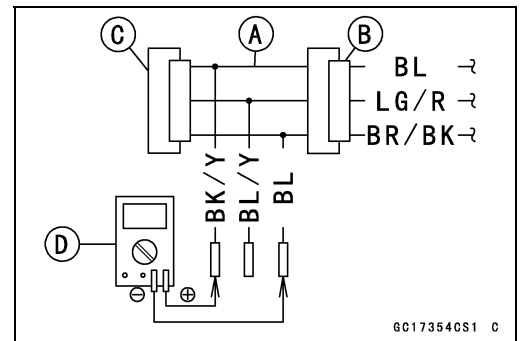

3-68 FUEL SYSTEM (DFI)

Speed Sensor (Service Code 24, 25)

Speed Sensor Output Voltage Inspection

- Before this inspection, inspect the input voltage (see Speed Sensor Input Voltage Inspection).

NOTE

○ Be sure the battery is fully charged.

- Turn the ignition switch OFF.
- Raise the rear wheel off the ground with jack (see Rear Wheel Removal in the Wheels/Tires chapter).
- Remove the speed sensor (see Speed Sensor Removal in the Electrical System chapter).
- Connect the measuring adapter [A] between the harness connector [B] and speed sensor connector [C].

Special Tool - Speed Sensor Measuring Adapter: 57001-1667

- Reinstall the speed sensor with the measuring adapter connected.
- Connect a digital meter [D] to the measuring adapter lead connectors.

Speed Sensor Output Voltage Connections to Adapter

Meter (+) → BL/Y (sensor LG/R) lead

Meter (-) → BL (sensor BR/BK) lead

- Measure the output voltage with the engine stopped, and with the connectors joined.
- Turn the ignition switch ON.

Output Voltage at Sensor

Standard: About DC 0.05 ~ 0.09 V or DC 4.5 ~ 4.9 V

- Rotate the rear wheel by hand, confirm the output voltage will be raise or lower.
- ★ If the reading is out of the range, check the speed sensor and the wiring to ECU (see next diagram).
- ★ If the reading, speed sensor and wiring are good, replace the ECU.
- Turn the ignition switch OFF.

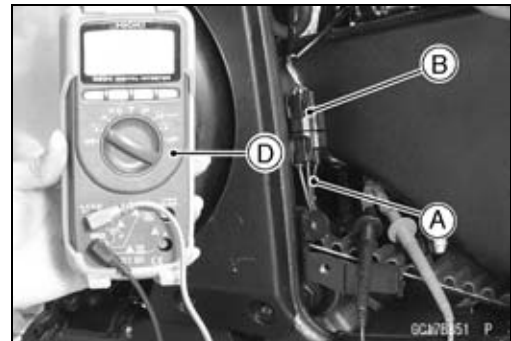
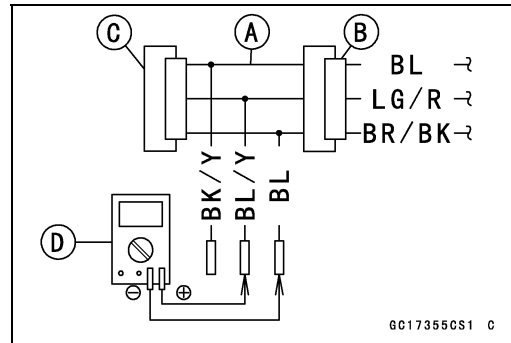

Speed Sensor (Service Code 24, 25)

Speed Sensor Circuit (Without Oxygen Sensor Equipped Models)

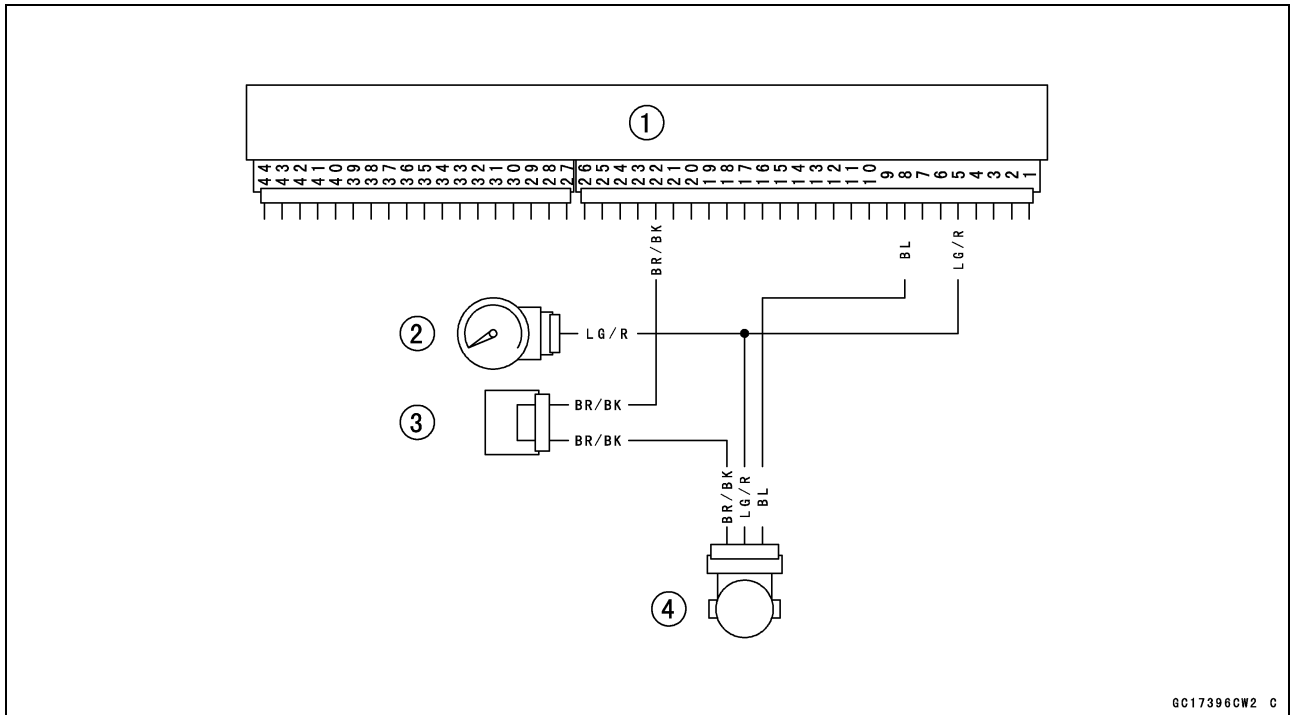

Speed Sensor Circuit (Oxygen Sensor Equipped Models)

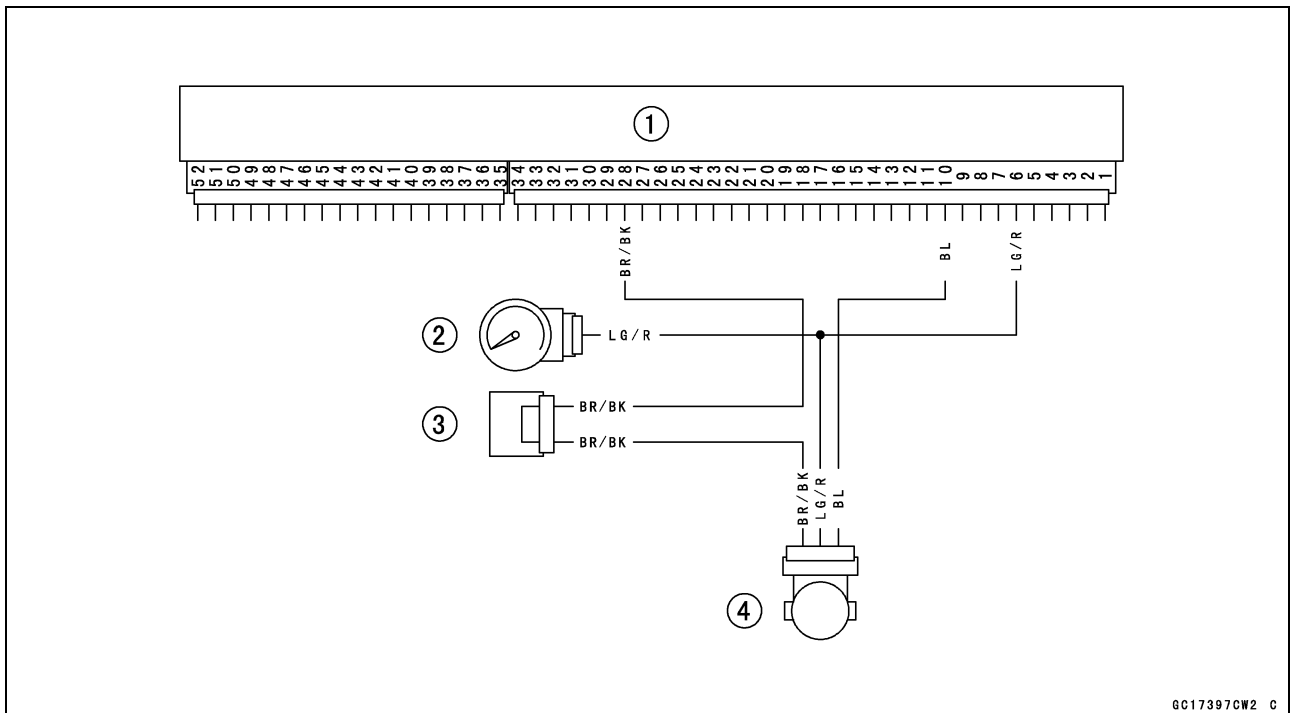

1. ECU
2. Meter Unit
3. Joint Connector B
4. Speed Sensor

3-70 FUEL SYSTEM (DFI)

Vehicle-down Sensor (Service Code 31)

Vehicle-down Sensor Removal

- Remove:
 - Tool Box (see Tool Box Removal in the Frame chapter)
 - Bolts [A]
 - Vehicle-down Sensor [B]
 - Connector [C] (Disconnect)

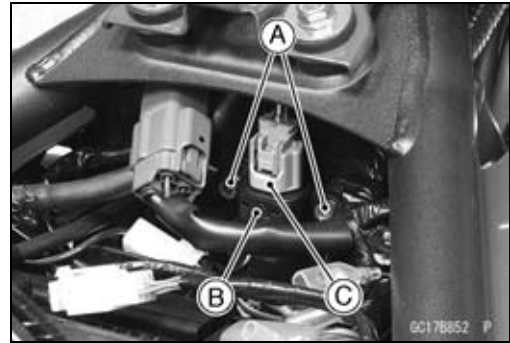

Vehicle-down Sensor Installation

- Install the vehicle-down sensor [A] in the original position. The arrow mark [B] on the sensor must be on the rear and point upward.
 - Do not install the sensor upside down.
 - Tighten:
 - Torque - Vehicle-down Sensor Bolts [C]: 1.0 N·m (0.10 kgf·m, 8.9 in·lb)
- Front [D]

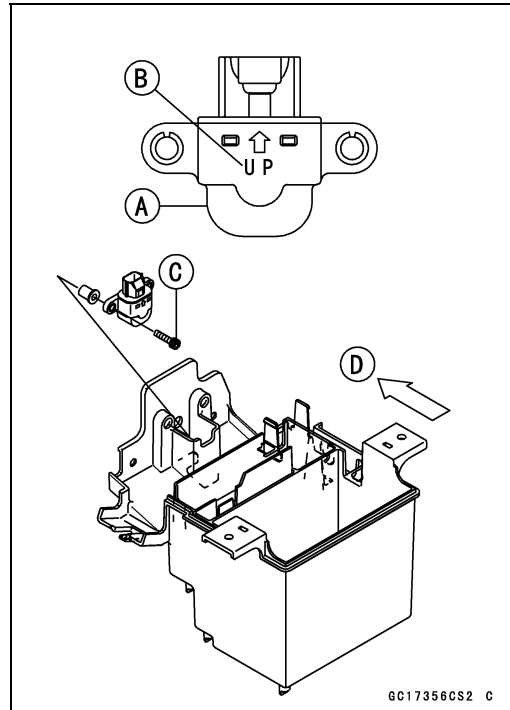

⚠ WARNING

Incorrect installation of the vehicle-down sensor could cause sudden loss of engine power. The rider could lose balance during certain riding situations, like leaning over in a turn, with the potential for an accident resulting in injury or death. Ensure that the down sensor is held in place by its bolt as shown in the figure.

Vehicle-down Sensor Inspection

NOTE

○Be sure the battery is fully charged.

- Take out the vehicle-down sensor [A] (see Vehicle-down Sensor Removal). Do not disconnect the connector [B].
- Connect a digital meter [C] to the connector, using the needle adapter set [D].

Special Tool - Needle Adapter Set: 57001-1457

- Turn the ignition switch ON, and measure the power source voltage with the connector joined.

Vehicle-down Sensor Power Source Voltage Connections to Sensor

Meter (+) → BL lead [E]

Meter (-) → BR/BK lead [F]

Standard: DC 4.75 ~ 5.25 V

- Turn the ignition switch OFF.
- ★ If the reading of input voltage is less than the standard, check the ECU for its ground, power supply and wiring shorted.

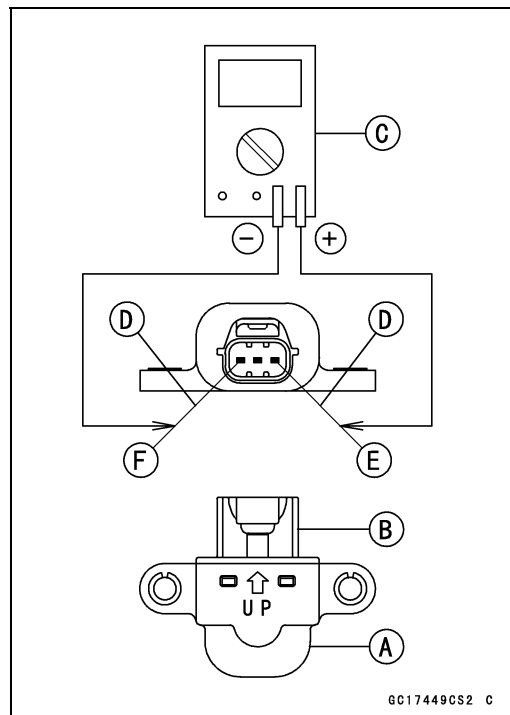

Vehicle-down Sensor (Service Code 31)

- ★ If the power source is normal, check the output voltage of the sensor.
- Connect a digital meter [A] to the connector, using the needle adapter set [B].
- Turn the ignition switch ON, and measure the output voltage with the connector joined.
- Tilt the sensor (40 ~ 50°) or more [C] right or left, then hold the sensor almost vertical [D] with the arrow mark pointed up, and measure the output voltage.

Vehicle-down Sensor Output Voltage Connections to Sensor

Meter (+) → Y/G lead [E]

Meter (-) → BR/BK lead [F]

Standard: with sensor arrow mark pointed up: 3.55 ~ 4.45 V
 with sensor tilted 40 ~ 50° or more right or left: 0.65 ~ 1.35 V

NOTE

○ If you need to test again, turn the ignition switch OFF, and then ON.

- Turn the ignition switch OFF.
- Remove the needle adapter set, and apply silicone sealant to the seals of the connector for waterproofing.

Sealant - Liquid Gasket, TB1211: 56019-120

- ★ If the output voltage is out of the specified, replace the vehicle-down sensor.
- ★ If the output voltage is normal, the wiring is suspect. Check the wiring.

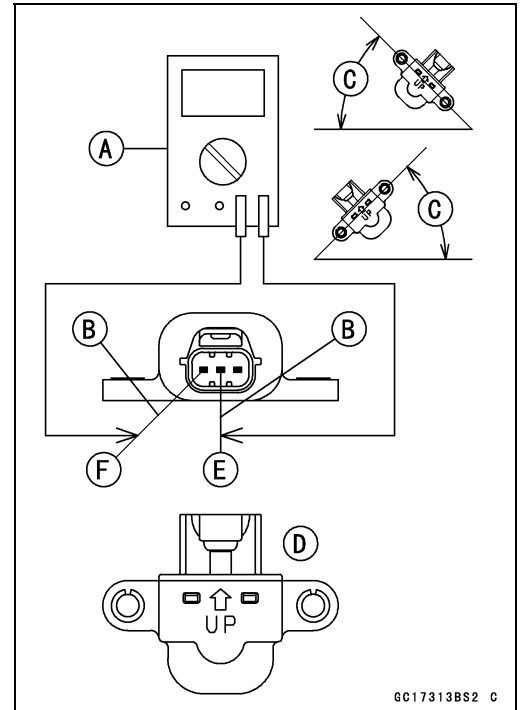

3-72 FUEL SYSTEM (DFI)

Vehicle-down Sensor (Service Code 31)

Vehicle-down Sensor Circuit (Without Oxygen Sensor Equipped Models)

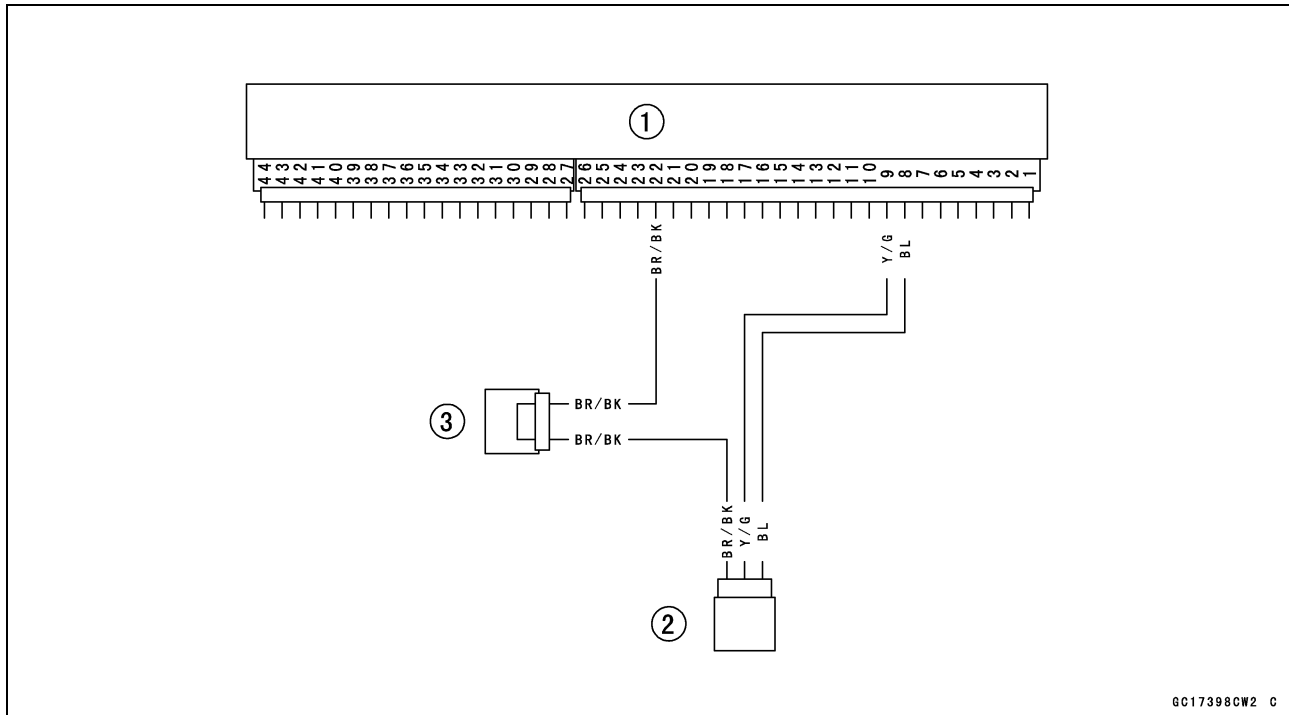

Vehicle-down Sensor Circuit (Oxygen Sensor Equipped Models)

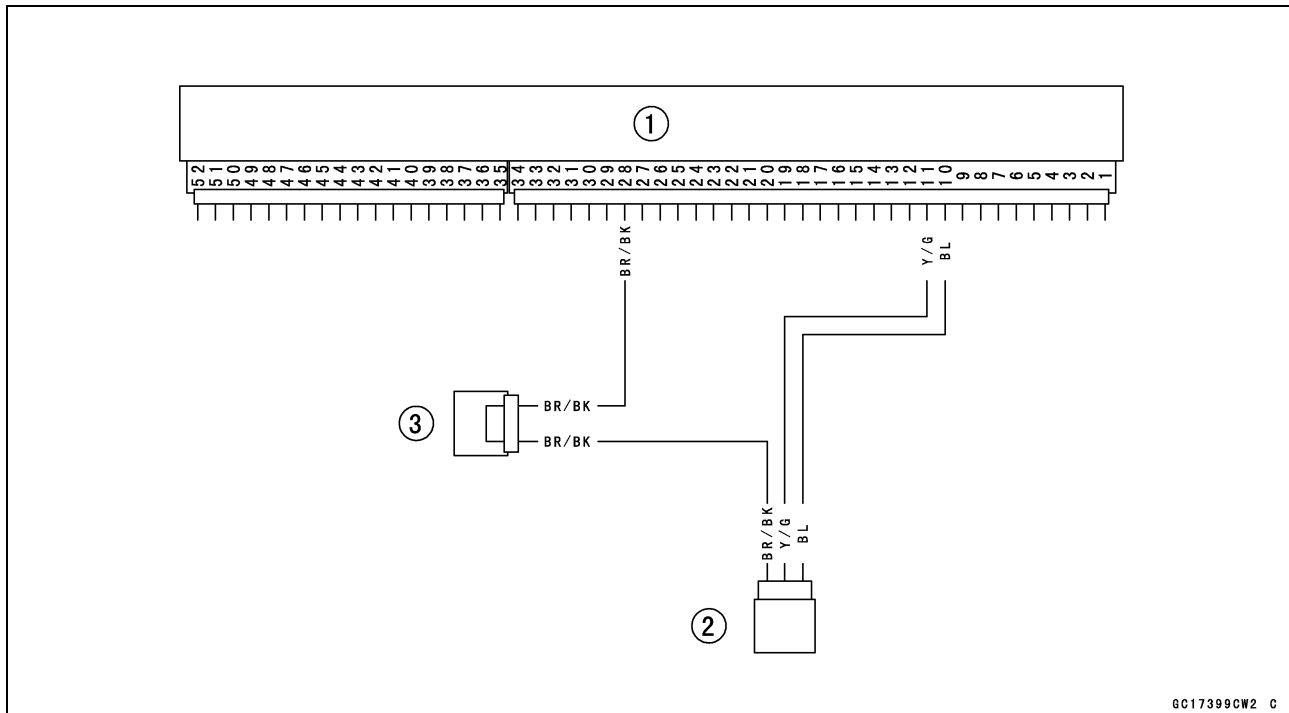

- 1. ECU
- 2. Vehicle-down Sensor
- 3. Joint Connector B

Subthrottle Sensor (Service Code 32)

The subthrottle sensor is a rotating variable resistor that change output voltage according to throttle operating. The ECU senses this voltage change and determines fuel injection quantity, and ignition timing according to engine rpm, and throttle opening.

- Input Terminal [A]
- Output Terminal [B]
- Ground Terminal [C]

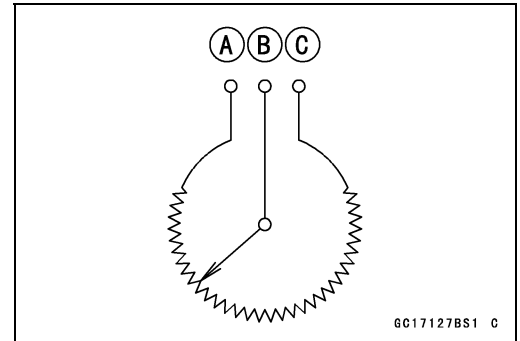

Subthrottle Sensor Removal/Adjustment

NOTICE

Do not remove or adjust the subthrottle sensor [A] since it has been adjusted and set with precision at the factory.
Never drop the throttle body assy, especially on a hard surface. Such a shock to the sensor can damage it.

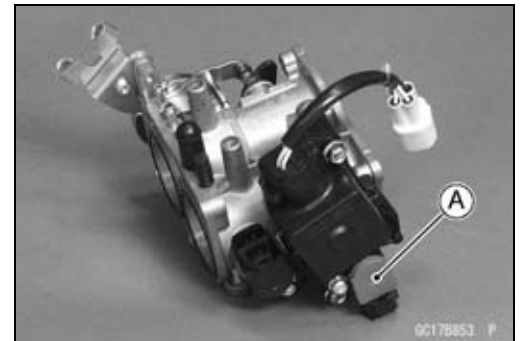

Subthrottle Sensor Input Voltage Inspection

NOTE

- Be sure the battery is fully charged.
- The inspection is the same as "Input Voltage Inspection" of the inlet air pressure sensor and the atmospheric pressure sensor.

- Turn the ignition switch OFF.
- Remove the ECU (see ECU Removal). Do not disconnect the ECU connectors.
- Connect a digital voltmeter to the connector, using the needle adapter set.

Special Tool - Needle Adapter Set: 57001-1457

Subthrottle Sensor Input Voltage

Connections to ECU Connector

(Without Oxygen Sensor Equipped Models [A])

- Meter (+) → BL lead (terminal 8)
- Meter (-) → BR/BK lead (terminal 22)

(Oxygen Sensor Equipped Models [B])

- Meter (+) → BL lead (terminal 10)
- Meter (-) → BR/BK lead (terminal 28)

- Measure the input voltage with the engine stopped, and with the connectors joined.
- Turn the ignition switch ON.

Input Voltage at ECU Connector

Standard: DC 4.75 ~ 5.25 V

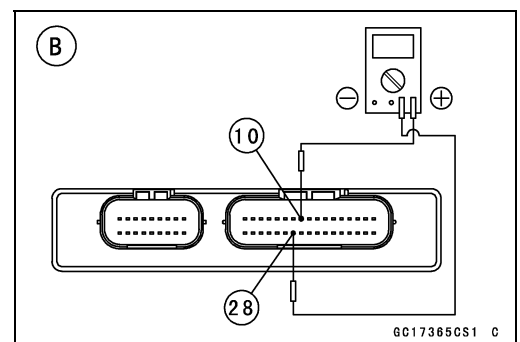
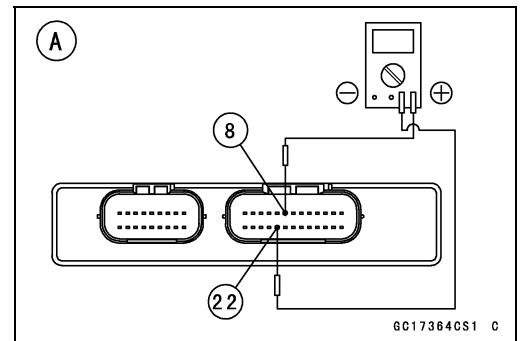

3-74 FUEL SYSTEM (DFI)

Subthrottle Sensor (Service Code 32)

- Turn the ignition switch OFF.
- ★ If the reading of input voltage is less than the standard, check the ECU for its ground, power supply and wiring shorted.
- ★ If the input voltage is within the standard range, remove the fuel tank, and check wiring from ECU to the subthrottle sensor for continuity.
- ★ If the wiring is good, check the output voltage of the subthrottle sensor.

Subthrottle Sensor Output Voltage Inspection

- Measure the output voltage at the ECU in the same way as input voltage inspection.

Special Tool - Needle Adapter Set: 57001-1457

Subthrottle Sensor Output Voltage Connections to ECU

(Without Oxygen Sensor Equipped Models [A])

Meter (+) → BL/W lead (terminal 19)

Meter (-) → BR/BK lead (terminal 22)

(Oxygen Sensor Equipped Models [B])

Meter (+) → BL/W lead (terminal 24)

Meter (-) → BR/BK lead (terminal 28)

- Turn the ignition switch ON.
- Measure the output voltage when the subthrottle valve is fully opened or completely closed by hand.

Output Voltage at ECU

Standard: DC 0.93 ~ 4.59 V (at subthrottle valve full opening to closing)

NOTE

- The subthrottle sensor is operating correctly if the following voltages are obtained.
 - DC 0.93 V (or slightly higher) with the subthrottle valve at the closed position.
 - DC 4.59 V (or slightly lower) with the subthrottle valve at the fully open position.

NOTICE

Do not remove or adjust the subthrottle sensor. It has been adjusted and set with precision at the factory.

Never drop the throttle body assy, can especially on a hard surface. Such a shock to the sensor can damage it.

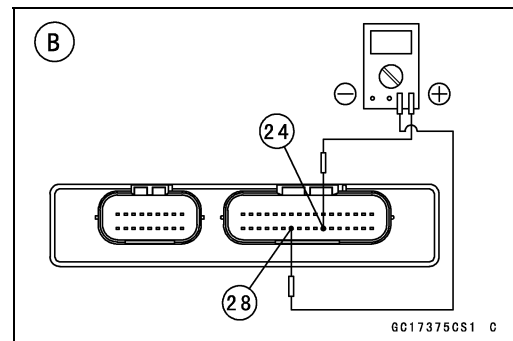
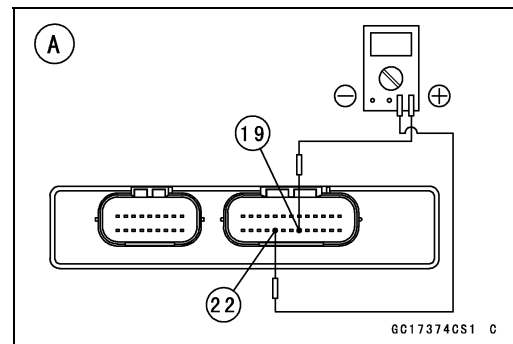

Subthrottle Sensor (Service Code 32)

NOTE

- The standard voltage refers to the value when the voltage reading at the Input Voltage Inspection shows 5 V exactly.
- When the input voltage reading shows other than 5 V, derive a voltage range as follows.

Example:

In the case of a input voltage of 4.75 V.

$$0.93 \times 4.75 \div 5.00 = 0.88 \text{ V}$$

$$4.59 \times 4.75 \div 5.00 = 4.36 \text{ V}$$

Thus, the valid range is 0.88 ~ 4.36 V

- ★ If the output voltage is within the standard range, check the wiring for continuity (see next diagram).
- ★ If the output voltage is far out of the standard range (e.g. when the wiring is open, the reading is 0 V), check the subthrottle sensor resistance.

**Subthrottle Sensor Resistance Inspection
VN900C7**

- Turn the ignition switch OFF.
- Disconnect the subthrottle sensor connector.
- Connect a digital meter [A] to the subthrottle sensor connector [B].
- Measure the subthrottle sensor resistance.

Subthrottle Sensor Resistance

Connections: BL lead [C] ↔ BR/BK lead [D]

Standard: 4 ~ 6 kΩ

- ★ If the reading is out of the range, replace the throttle body assy.
- ★ If the reading is within the range, but the problem still exists, replace the ECU.

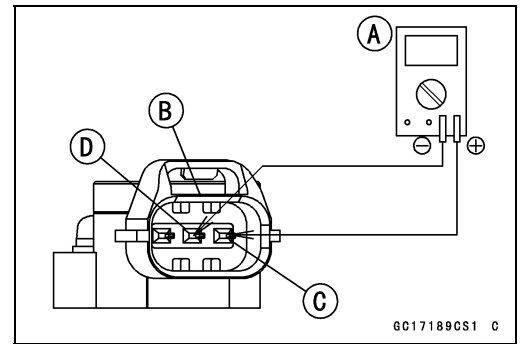

VN900C8 ~

- Turn the ignition switch OFF.
- Disconnect the subthrottle sensor connector.
- Connect a digital meter [E] to the subthrottle sensor connector [F].
- Measure the subthrottle sensor resistance.

Subthrottle Sensor Resistance

Connections: BL lead [G] ↔ BK lead [H]

Standard: 4 ~ 6 kΩ

- ★ If the reading is out of the range, replace the throttle body assy.
- ★ If the reading is within the range, but the problem still exists, replace the ECU.

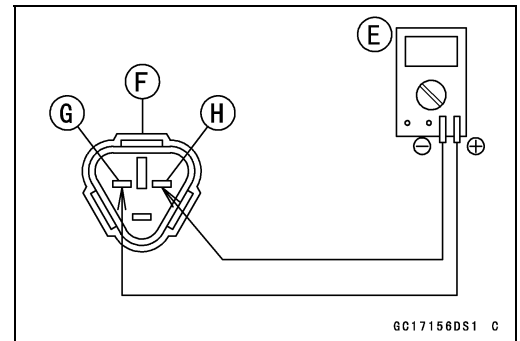

3-76 FUEL SYSTEM (DFI)

Subthrottle Sensor (Service Code 32)

Subthrottle Sensor Circuit (Without Oxygen Sensor Equipped Models)

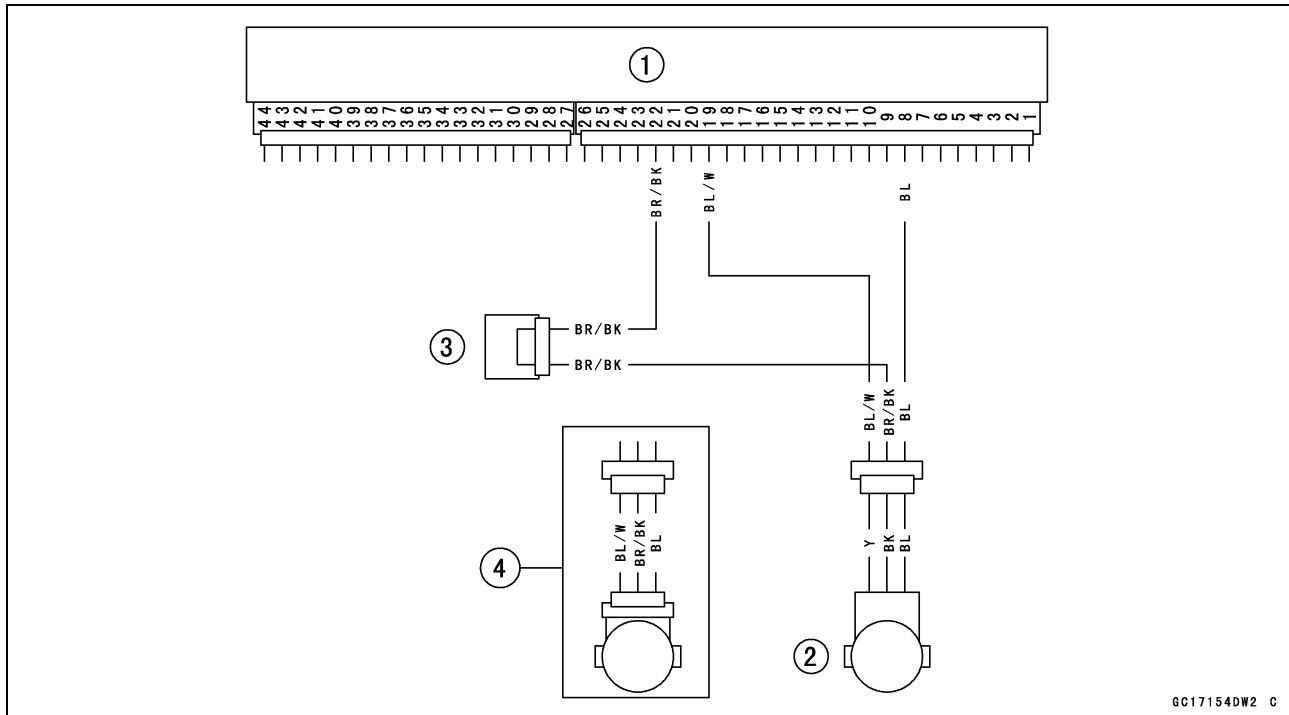

Subthrottle Sensor Circuit (Oxygen Sensor Equipped Models)

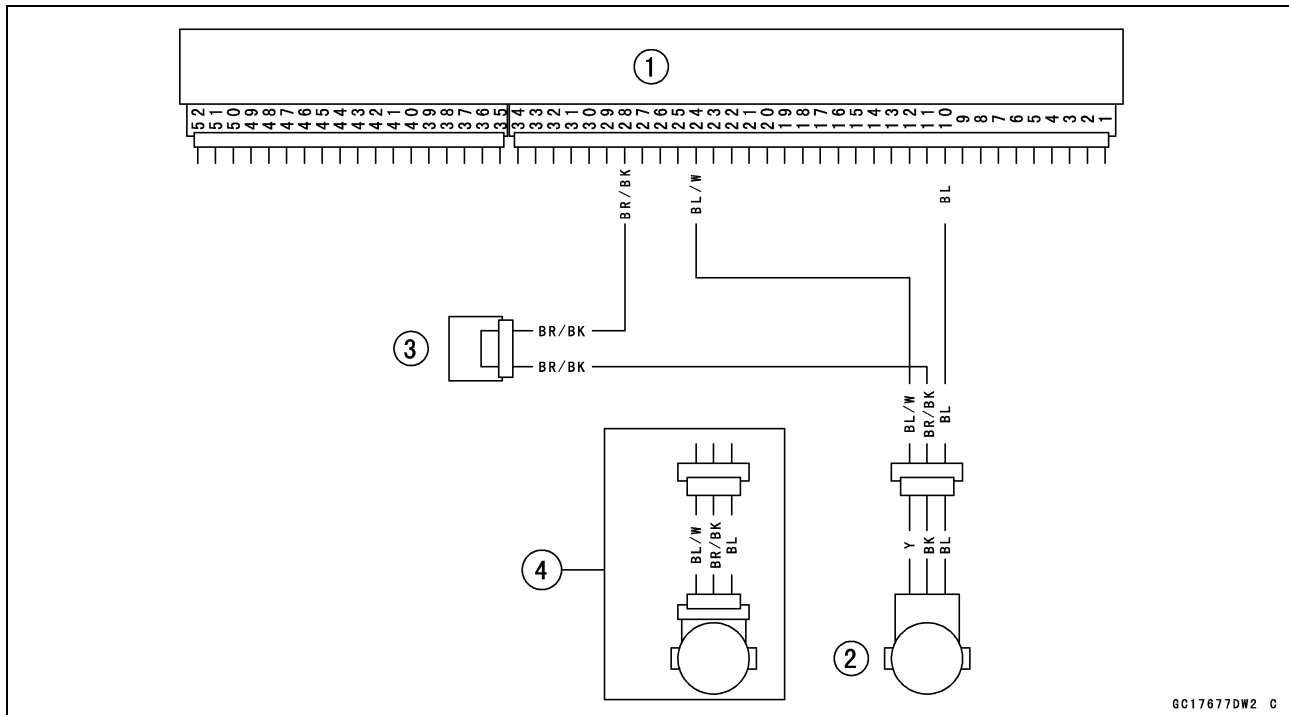

- 1. ECU
- 2. Subthrottle Sensor (VN900C8 ~ Models)
- 3. Joint Connector B
- 4. Subthrottle Sensor (VN900C7 Models)

Oxygen Sensor-not activated #1, #2 (Service Code 33, 83) (Oxygen Sensor Equipped Models)

Oxygen Sensor #1: Service Code 33
 Oxygen Sensor #2: Service Code 83

Oxygen Sensor Removal/Installation

- Refer to the Oxygen Sensor Removal and Installation in the Electrical System chapter.

Oxygen Sensor Inspection

NOTE

- The oxygen sensor itself is the same for #1 [A] and #2 [B], but wiring of the main harness side is different.

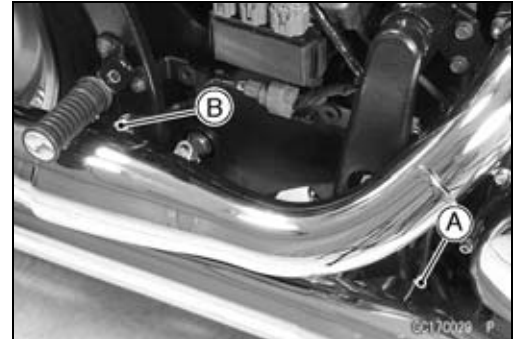

- Warm up the engine thoroughly.
- Turn the ignition switch OFF.
- Remove the right side cover (see Right Side Cover Removal in the Frame chapter).
- Connect a digital voltmeter [A] to the each oxygen sensor connector [B] (sensor side), using the needle adapter set.

Special Tool - Needle Adapter Set: 57001-1457

Oxygen Sensor Output Voltage

Connections to Oxygen Sensor Connector

- Meter (+) → BK lead**
- Meter (-) → GY lead**

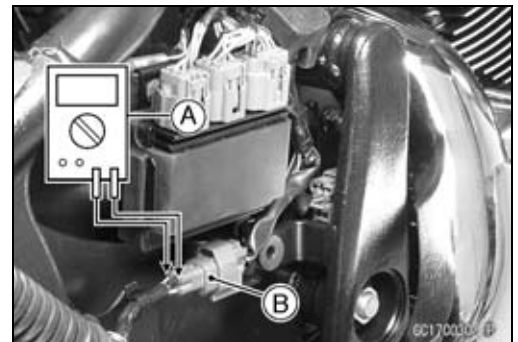

- Disconnect the air switching valve hoses [A] (both sides) from the fittings.



- Install the suitable plugs [A] (both sides) on the fittings and shut off the secondary air.
- Turn the ignition switch ON.
- Start the engine, and let it idle.
- Measure the output voltage of the sensor with the connector joined.

Oxygen Sensor Output Voltage (with Plugs)

Standard: 0.45 ~ 2.5 V



3-78 FUEL SYSTEM (DFI)

Oxygen Sensor-not activated #1, #2 (Service Code 33, 83) (Oxygen Sensor Equipped Models)

- Next, remove the plugs [A] (both sides) from the fittings with idling.
- Measure the output voltage of the sensor with the connector joined.

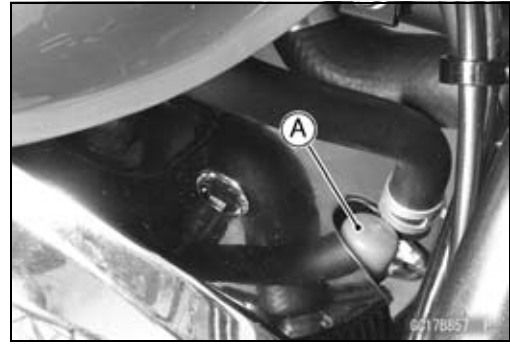

Oxygen Sensor Output Voltage (without Plugs)

Standard: 0.05 ~ 0.45 V

- ★ If the reading is within range (with plugs: 0.45 ~ 2.5 V, without plugs: 0.05 ~ 0.45 V), the oxygen sensor is good.
- ★ If the reading is without range, replace the oxygen sensor.
- Remove the needle adapter set, and apply silicone sealant to the seals of the connector for waterproofing.

Sealant - Liquid Gasket, TB1211: 56019-120

Oxygen Sensor Circuit (VN900C7 ~ C8)

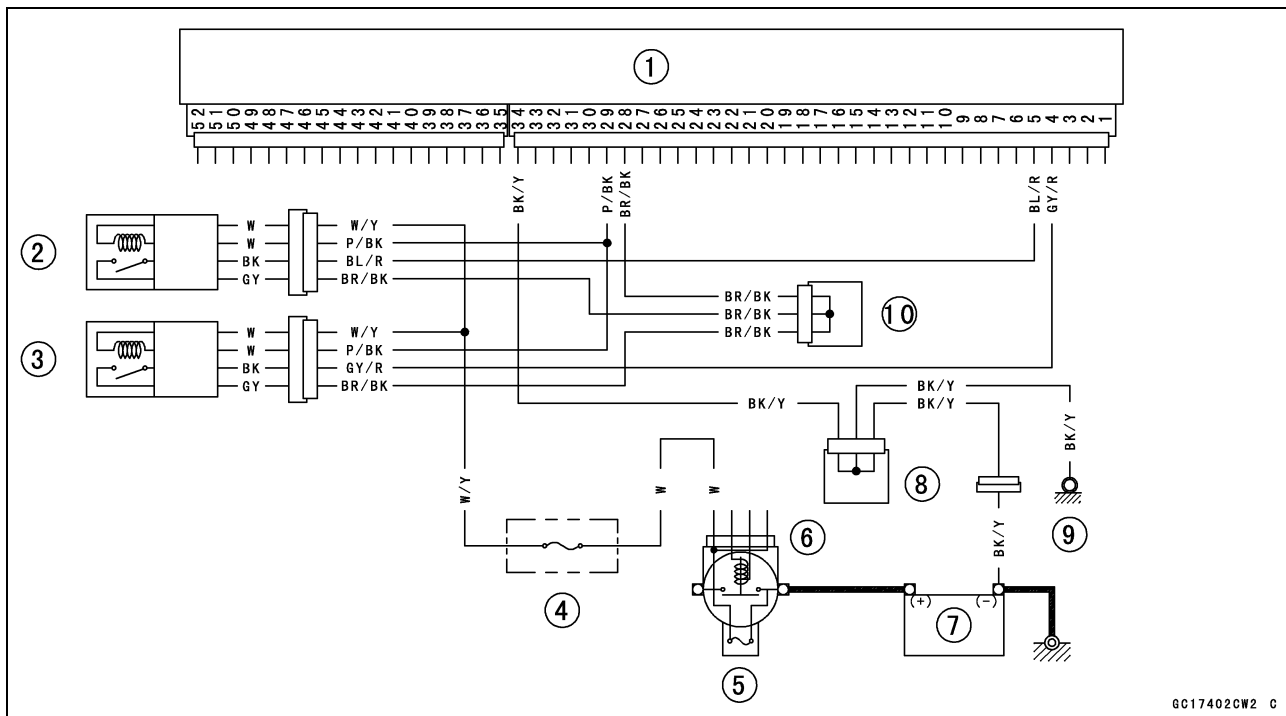

GC17402CW2 C

1. ECU
2. Oxygen Sensor #1
3. Oxygen Sensor #2
4. Oxygen Sensor Heater Fuse 10 A
5. Main Fuse 30 A
6. Starter Relay
7. Battery
8. Joint Connector C
9. Frame Ground
10. Joint Connector B

Oxygen Sensor-not activated #1, #2 (Service Code 33, 83) (Oxygen Sensor Equipped Models)

Oxygen Sensor Circuit (VN900C9 ~)

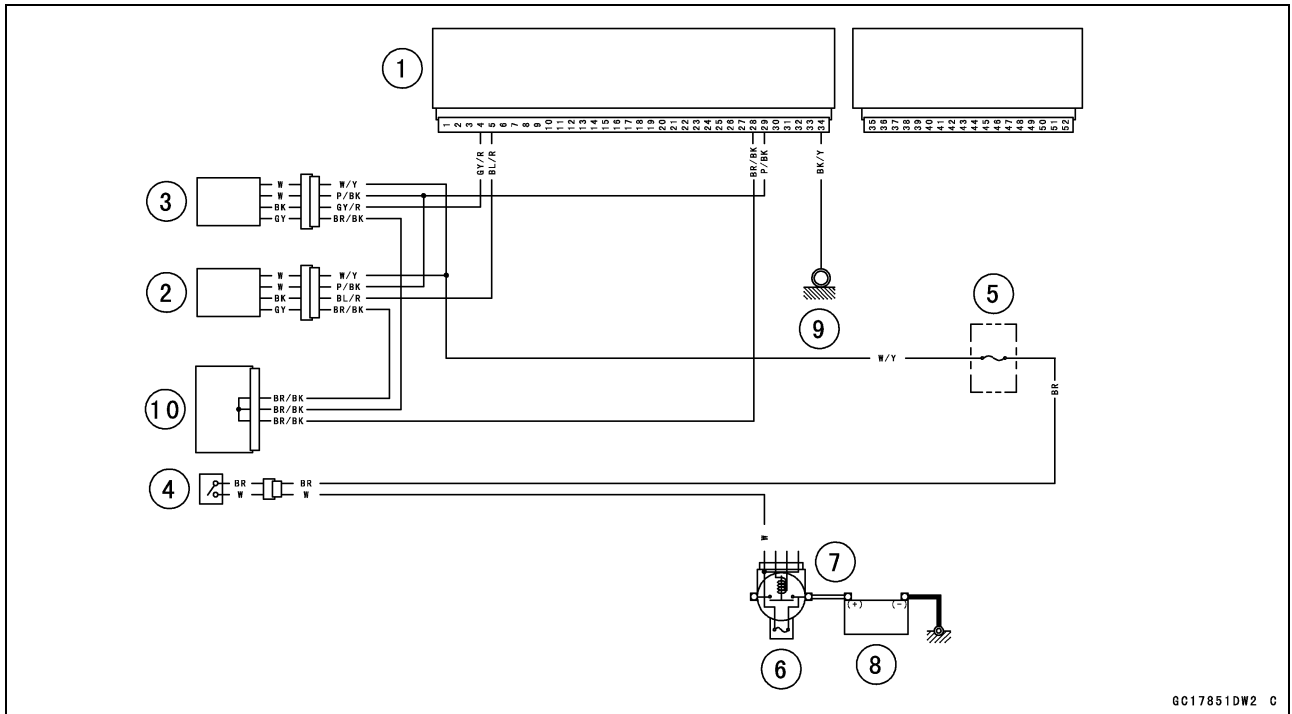

GC17851DW2 C

1. ECU
2. Oxygen Sensor #1
3. Oxygen Sensor #2
4. Ignition Switch
5. Oxygen Sensor Heater Fuse 10 A
6. Main Fuse 30 A
7. Starter Relay
8. Battery
9. Frame Ground
10. Joint Connector B

3-80 FUEL SYSTEM (DFI)

Ignition Coils #1, #2 (Service Code 51, 52)

Ignition Coil #1: Ignition Coil for Front Cylinder (Service Code 51)

Ignition Coil #2: Ignition Coil for Rear Cylinder (Service Code 52)

Ignition Coil Removal/Installation

NOTICE

Never drop the ignition coils, especially on a hard surface. Such a shock to the ignition coil can damage it.

- Refer to the Ignition Coil Removal and Installation in the Electrical System chapter.

Ignition Coil Input Voltage Inspection

NOTE

○ Be sure the battery is fully charged.

- Turn the ignition switch OFF.
- Remove the ECU (see ECU Removal). Do not disconnect the ECU connector.
- Connect a digital voltmeter as shown in the figure, using the needle adapter set.

Special Tool - Needle Adapter Set: 57001-1457

- Measure the input voltage to each primary winding of the ignition coils with the engine stopped, and with the connectors joined.
- Turn the ignition switch ON.

Ignition Coil Input Voltage at ECU

(Without Oxygen Sensor Equipped Models [A])

Connections for Ignition Coil #1

Meter (+) → BK lead (terminal 35)

Meter (-) → Battery (-) Terminal

Connections for Ignition Coil #2

Meter (+) → BK/G lead (terminal 44)

Meter (-) → Battery (-) Terminal

(Oxygen Sensor Equipped Models [B])

Connections for Ignition Coil #1

Meter (+) → BK lead (terminal 43)

Meter (-) → Battery (-) Terminal

Connections for Ignition Coil #2

Meter (+) → BK/G lead (terminal 52)

Meter (-) → Battery (-) Terminal

Standard: Battery Voltage (12.8 V or more)

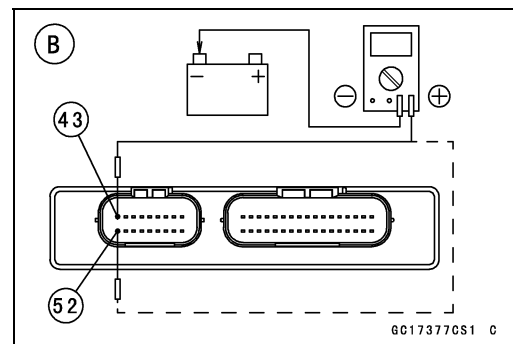
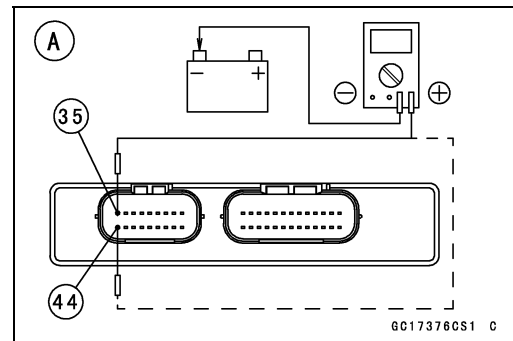

Ignition Coils #1, #2 (Service Code 51, 52)

- ★ If the reading is out of the standard, check the ECU for its ground and power supply (see ECU Power Supply Inspection).
- ★ If the reading is good, remove the fuel tank, and check the wiring between the ECU and the primary lead terminals at the ignition coils.
- ★ If the wiring is good, crank the engine, and check the peak voltage of the ignition coils (see Ignition Coil Primary Peak Voltage Inspection in the Electrical System chapter) in order to check the primary coils.

3-82 FUEL SYSTEM (DFI)

Radiator Fan Relay (Service Code 56)

Radiator Fan Relay Removal/Installation

- Radiator fan relay is built in the relay box.
- Remove the relay box (see Relay Box Removal in the Electrical System chapter).

Radiator Fan Relay Inspection

- Refer to the Relay Circuit Inspection in the Electrical System chapter.
- Remove the relay box and ECU (see ECU Removal). Do not disconnect the relay box and ECU connectors. Check the wiring for continuity, using the following diagram.
- ★ If wiring and radiator fan relay are good, check the ECU for its ground, and power supply (see ECU Power Supply Inspection). If the ground and power supply are good, replace the ECU.

Radiator Fan Relay (Service Code 56)

Radiator Fan Relay Circuit (VN900C7 ~ C8)

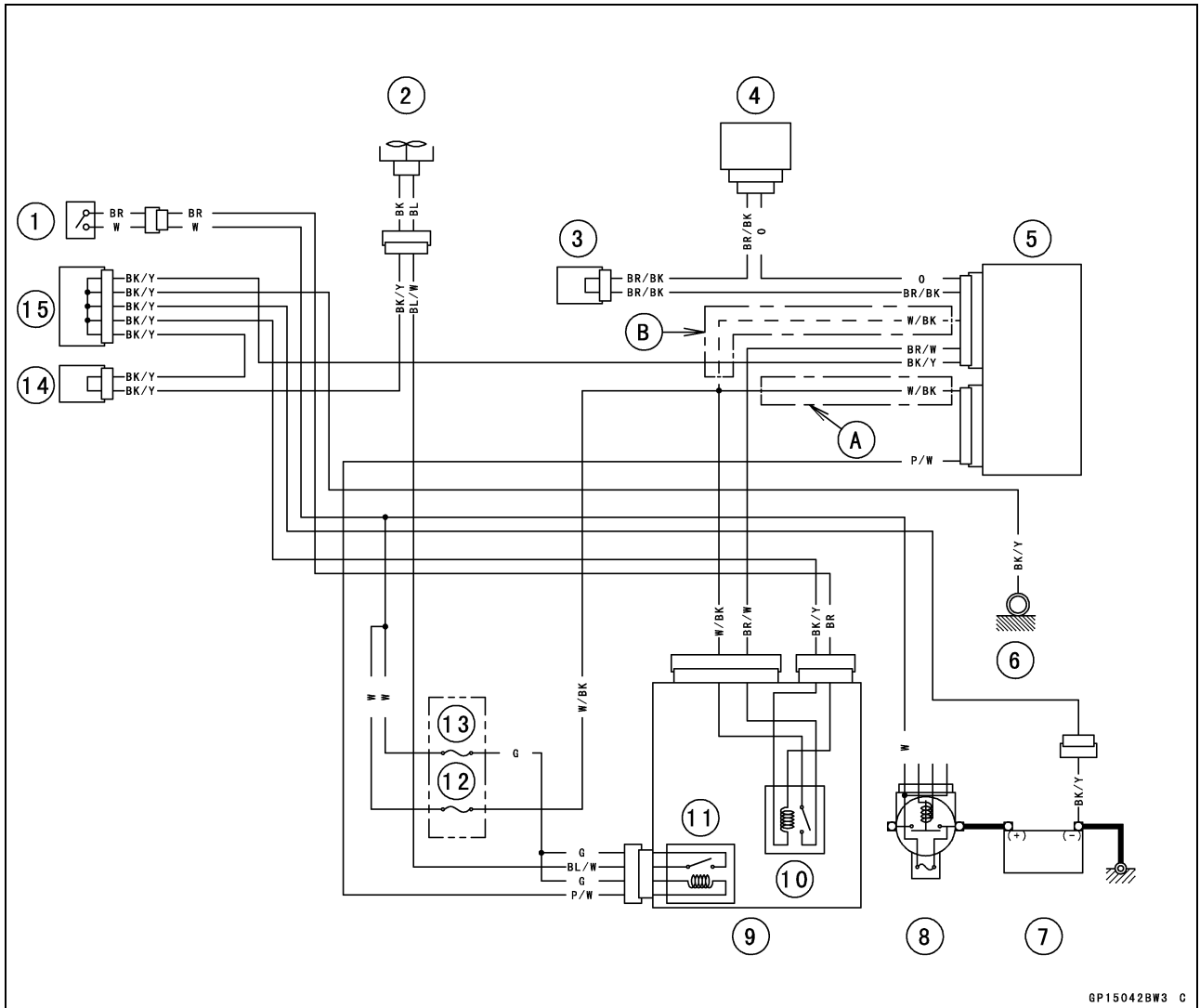

1. Ignition Switch
2. Radiator Fan
3. Joint Connector B
4. Water Temperature Sensor
5. ECU
6. Frame Ground
7. Battery
8. Main Fuse 30 A
9. Relay Box
10. ECU Main Relay
11. Radiator Fan Relay
12. ECU Fuse 15 A
13. Fan Fuse 15 A
14. Joint Connector A
15. Joint Connector C

A: Without Oxygen Sensor Equipped Models

B: Oxygen Sensor Equipped Models

3-84 FUEL SYSTEM (DFI)

Radiator Fan Relay (Service Code 56)

Radiator Fan Relay Circuit (VN900C9 ~)

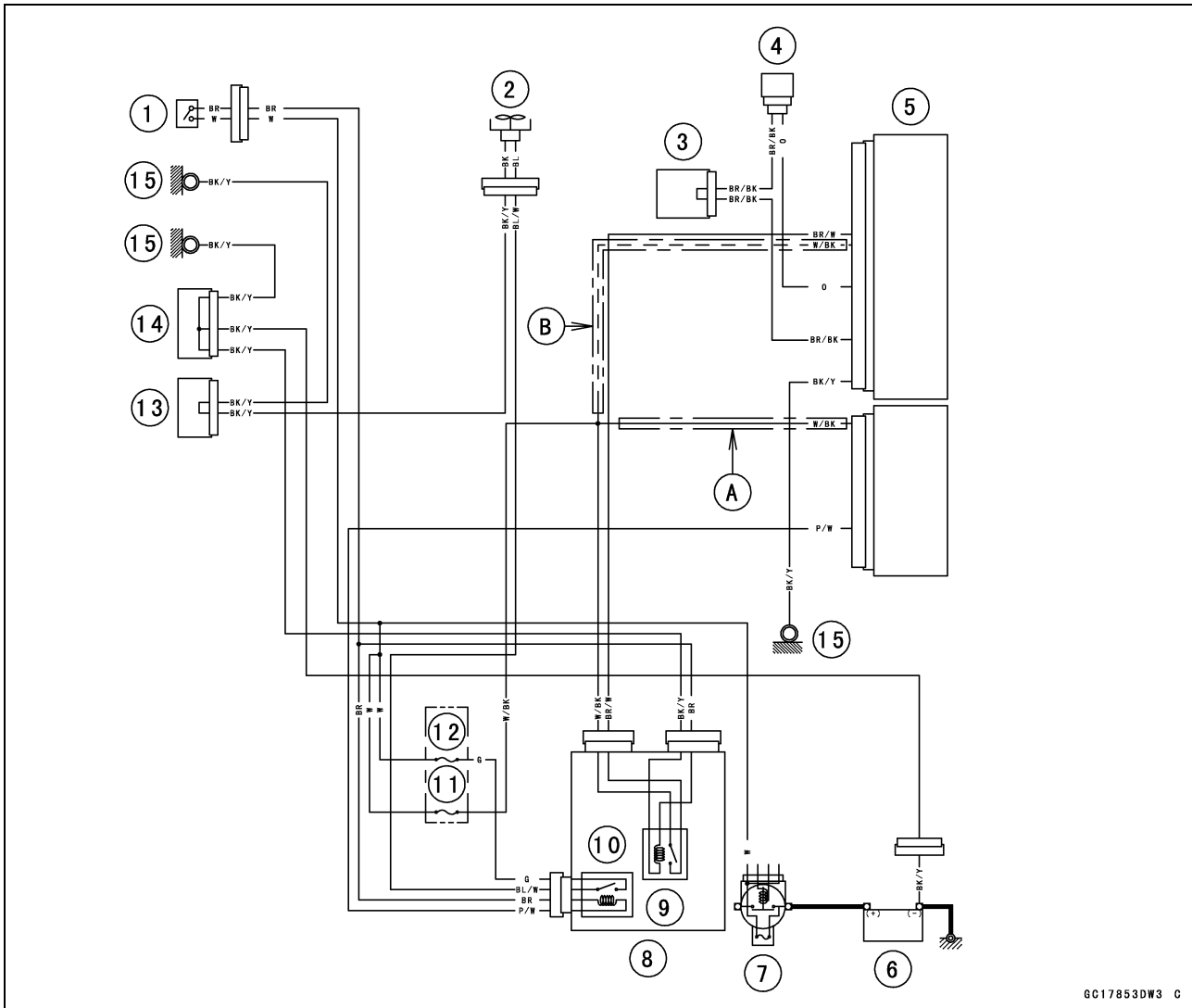

GC17853DW3 C

1. Ignition Switch
2. Radiator Fan
3. Joint Connector B
4. Water Temperature Sensor
5. ECU
6. Battery
7. Main Fuse 30 A
8. Relay Box
9. ECU Main Relay
10. Radiator Fan Relay
11. ECU Fuse 15 A
12. Fan Fuse 15 A
13. Joint Connector A
14. Joint Connector C
15. Frame Ground

A: Without Oxygen Sensor Equipped Models

B: Oxygen Sensor Equipped Models

Subthrottle Valve Actuator (Service Code 62)

Subthrottle Valve Actuator Removal

NOTICE

Do not remove the subthrottle valve actuator [A] since it has been adjusted and set with precision at the factory.
 Never drop the throttle body assy, especially on a hard surface. Such a shock to the actuator can damage it.

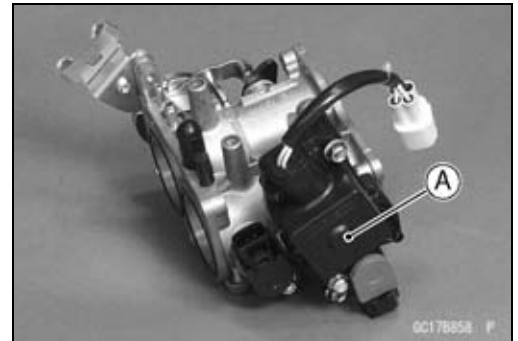

Subthrottle Valve Actuator Inspection

- Remove the air cleaner housing (see Air Cleaner Housing Removal).
- Turn the ignition switch ON.
- Check to see that all subthrottle valves [A] open and close smoothly.
- ★ If the subthrottle valves do not operate, check the actuator internal resistance (see Subthrottle Valve Actuator Resistance Inspection).

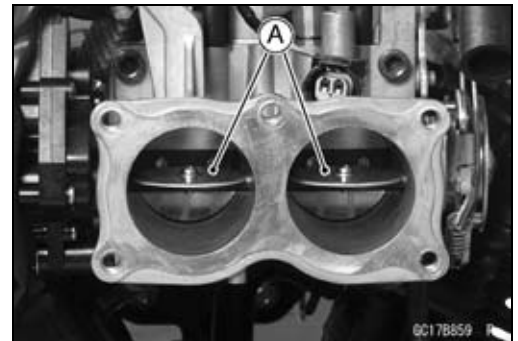

Subthrottle Valve Actuator Resistance Inspection

- Turn the ignition switch OFF.
 - Remove the fuel tank (see Fuel Tank Removal).
 - Disconnect the subthrottle valve actuator connector [A].
-
- Connect a digital meter to the subthrottle valve actuator connector [A].
 - Measure the subthrottle valve actuator resistance.



Subthrottle Valve Actuator Resistance

Connections: BK lead [1] ↔ P lead [2]
 G lead [3] ↔ W/BL lead [4]

Standard: About 5.2 ~ 7.8 Ω

- ★ If the reading is out of the range, replace the throttle body assy.
- ★ If the reading is within the range, check the input voltage (see Subthrottle Valve Actuator Input Voltage Inspection).

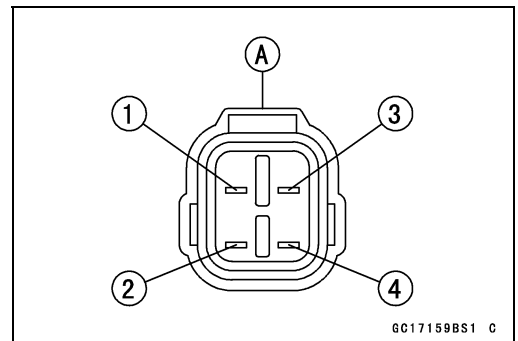

3-86 FUEL SYSTEM (DFI)

Subthrottle Valve Actuator (Service Code 62)

Subthrottle Valve Actuator Input Voltage Inspection

NOTE

○Be sure the battery is fully charged.

- Turn the ignition switch OFF.
- Remove the fuel tank (see Fuel Tank Removal).
- Connect the peak voltage adapter [A] and a digital meter [B] to the connector (main harness side) [C], using the needle adapter set [D].

Special Tools - Peak Voltage Adapter: 57001-1415

Type: KEK-54-9-B

Needle Adapter Set: 57001-1457

Subthrottle Valve Actuator Input Voltage Connections to Harness Connector

(I) Meter (+) → BK lead [1]

Meter (-) → P lead [2]

(II) Meter (+) → G lead [3]

Meter (-) → W/BL lead [4]

- Measure the actuator input voltage with the engine stopped, and with the connector joined.
- Turn the ignition switch ON.

Subthrottle Valve Actuator Input Voltage at Sensor

Standard: About DC 8.9 ~ 10.9 V

- ★ If the reading is out of the range, check the wiring to ECU (see next diagram).
- ★ If the wiring is good, replace the ECU.
- Install the fuel tank (see Fuel Tank Installation).

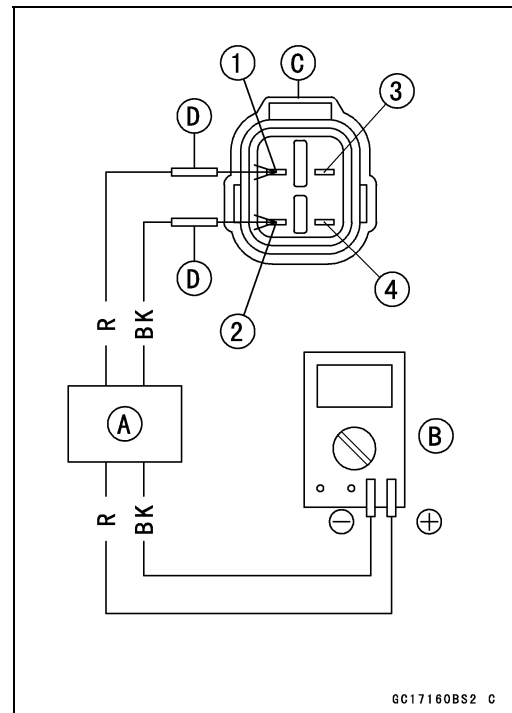
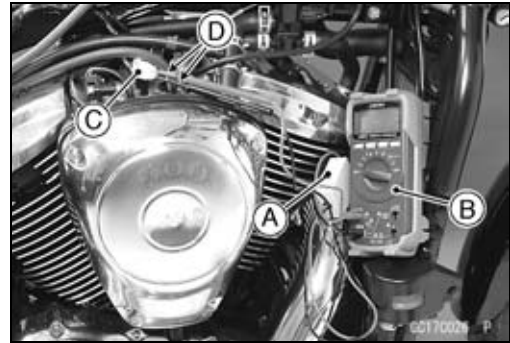

Subthrottle Valve Actuator (Service Code 62)

Subthrottle Valve Actuator Circuit (Without Oxygen Sensor Equipped Models)

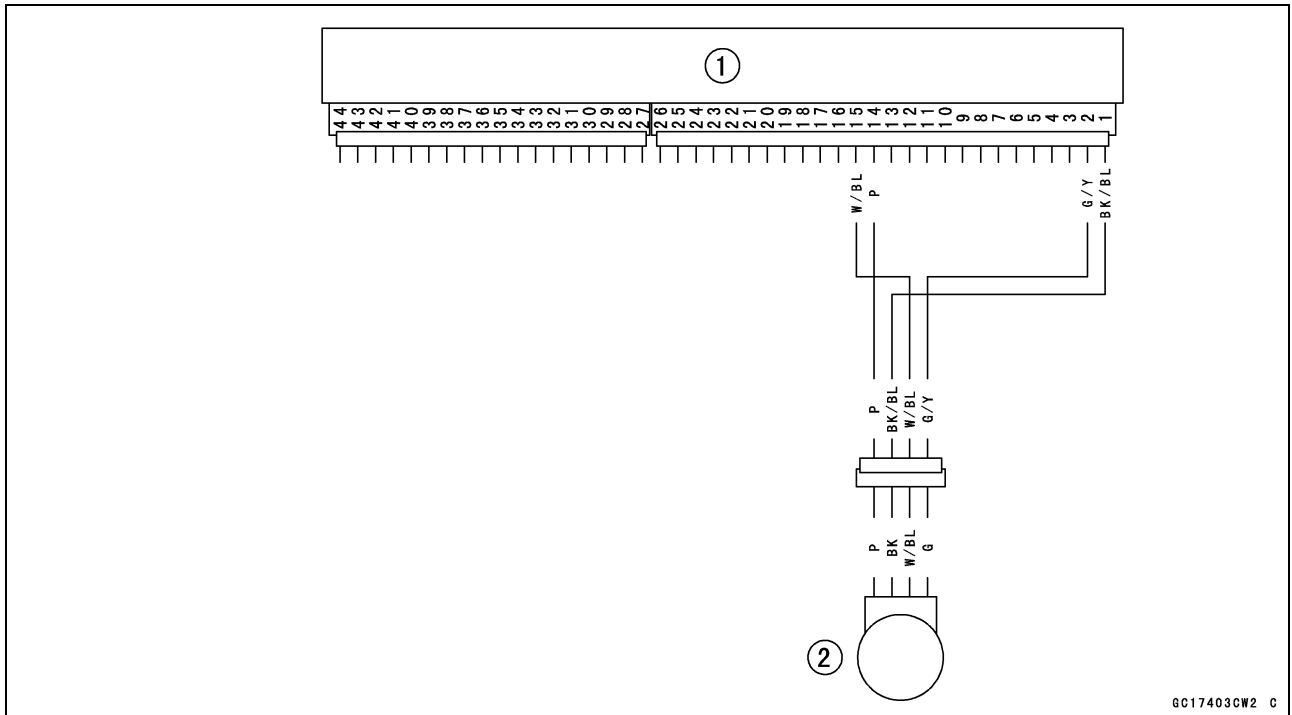

Subthrottle Valve Actuator Circuit (Oxygen Sensor Equipped Models)

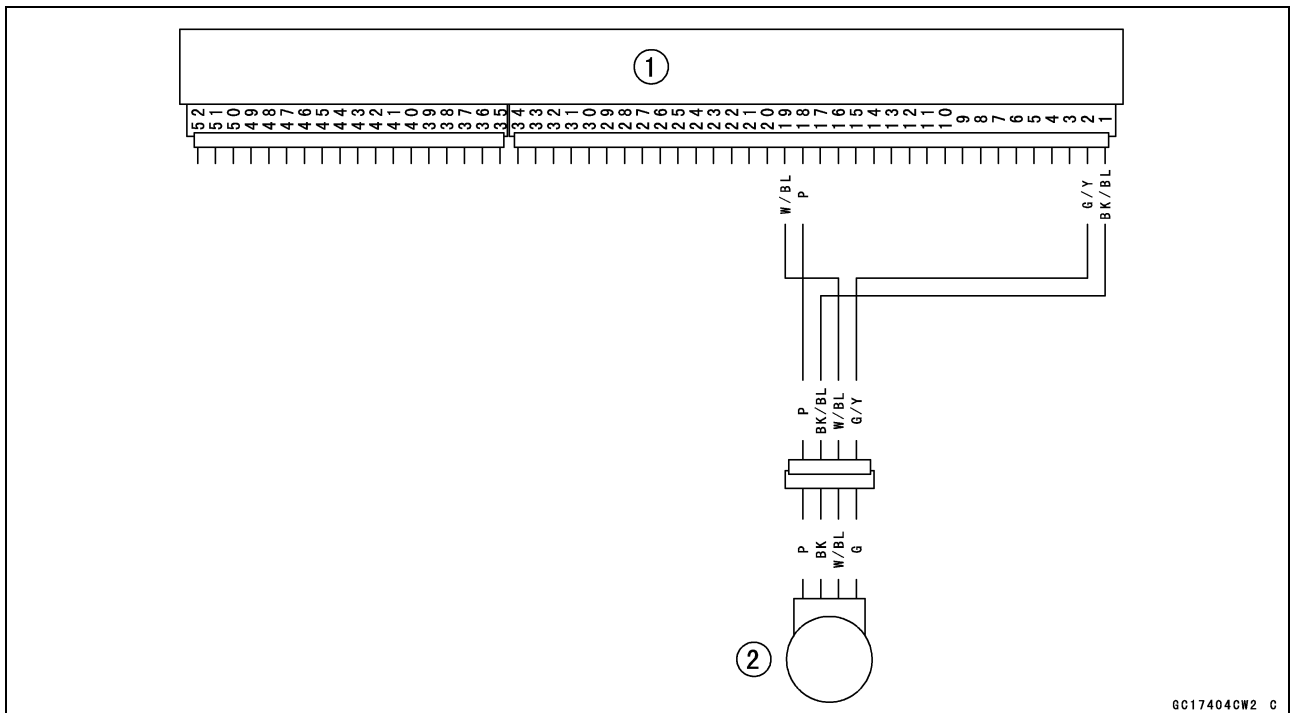

1. ECU
2. Subthrottle Valve Actuator

3-88 FUEL SYSTEM (DFI)

Air Switching Valve (Service Code 64)

Air Switching Valve Removal/Installation

- Refer to the Air Switching Valve Removal and Installation in the Engine Top End chapter.

Air Switching Valve Inspection

- Refer to the Air Switching Valve Unit Test in the Electrical System chapter.
- Check the wiring continuity, using the following diagram.

Air Switching Valve Circuit (Without Oxygen Sensor Equipped Models) (VN900C7 ~ C8)

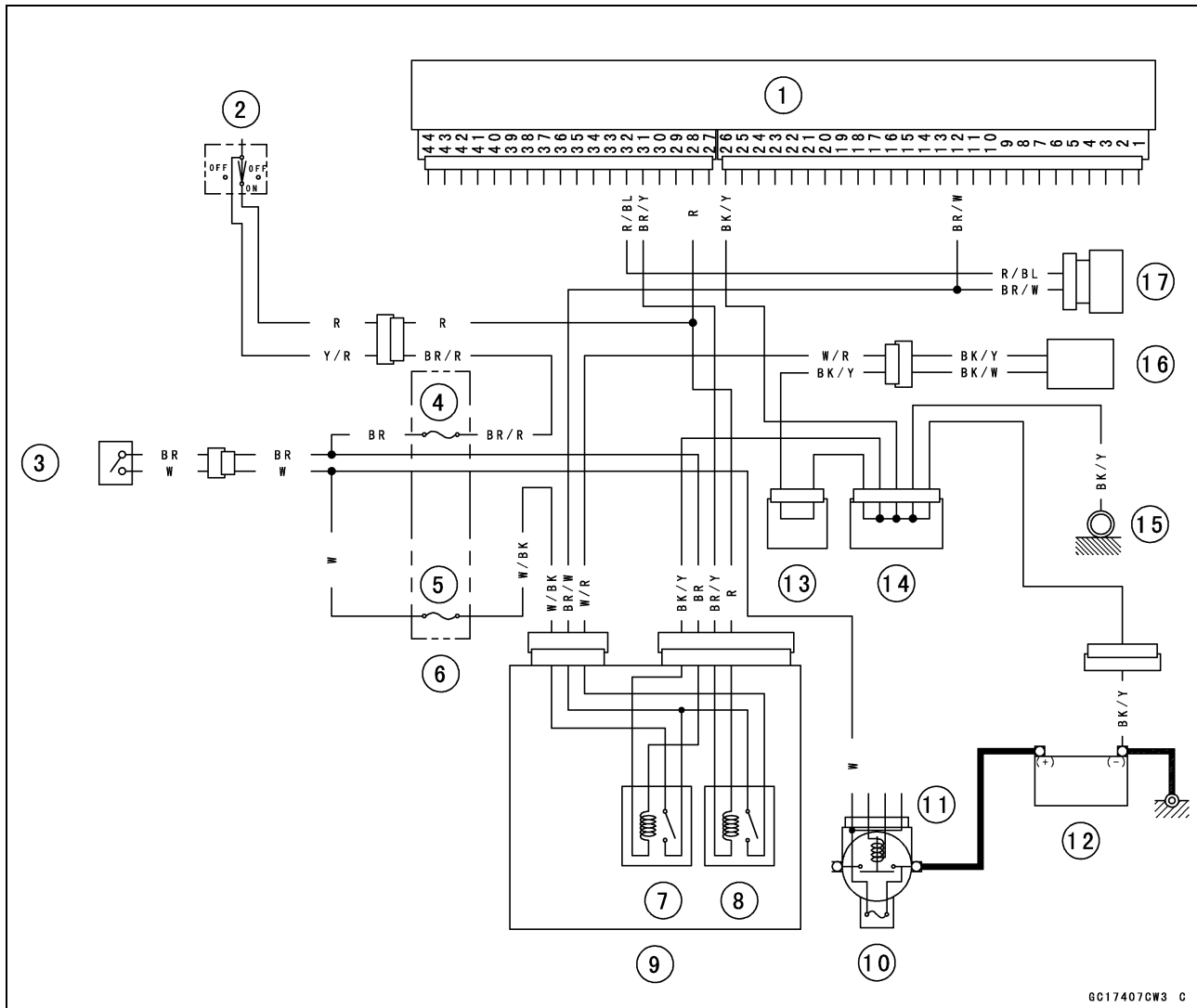

- | | |
|-----------------------|-------------------------|
| 1. ECU | 10. Main Fuse 30 A |
| 2. Engine Stop Switch | 11. Starter Relay |
| 3. Ignition Switch | 12. Battery |
| 4. Ignition Fuse 10 A | 13. Joint Connector A |
| 5. ECU Fuse 15 A | 14. Joint Connector C |
| 6. Fuse Box | 15. Frame Ground |
| 7. ECU Main Relay | 16. Fuel Pump |
| 8. Fuel Pump Relay | 17. Air Switching Valve |
| 9. Relay Box | |

Air Switching Valve (Service Code 64)

Air Switching Valve Circuit
(Oxygen Sensor Equipped Models) (VN900C7 ~ C8)

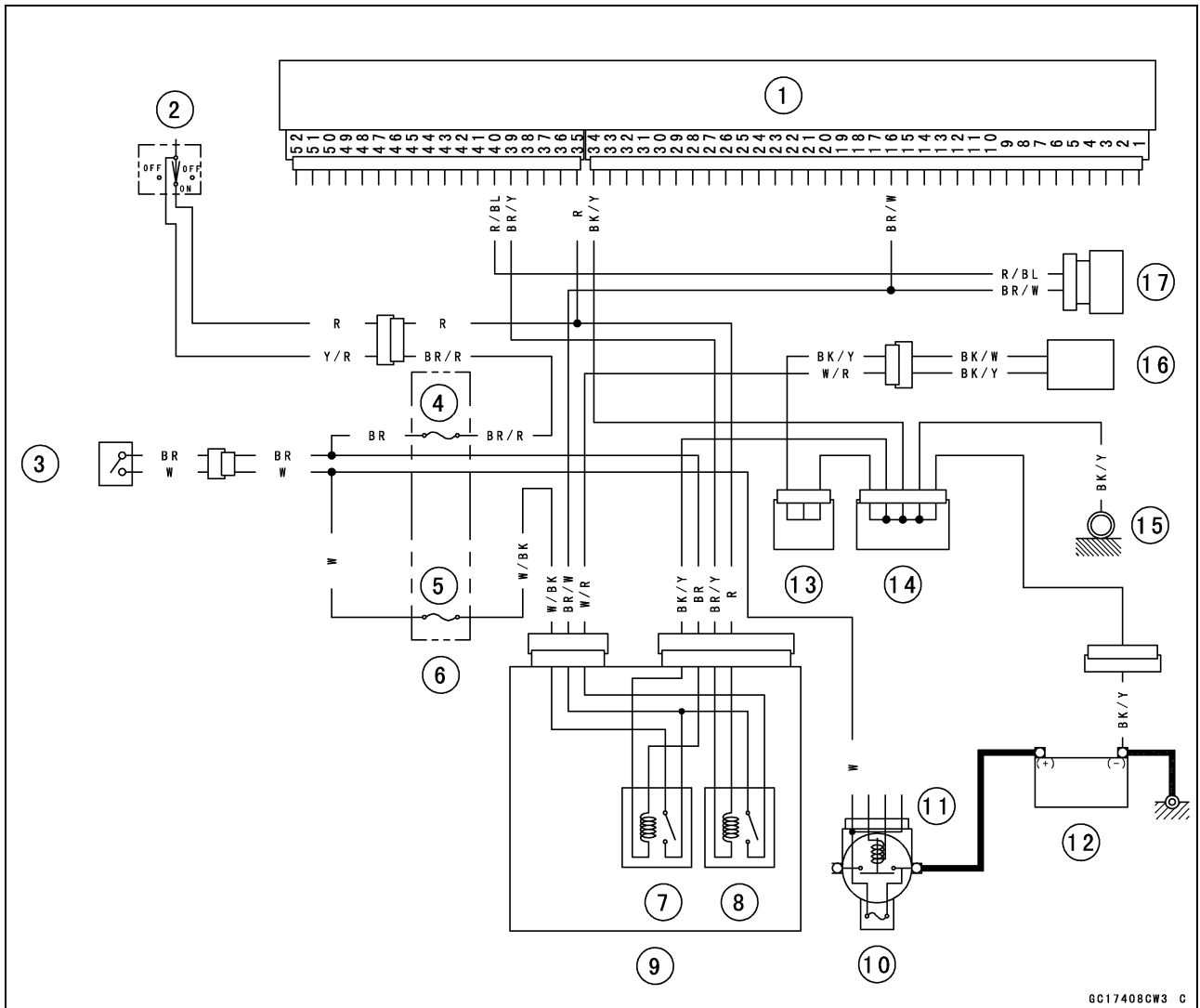

1. ECU
2. Engine Stop Switch
3. Ignition Switch
4. Ignition Fuse 10 A
5. ECU Fuse 15 A
6. Fuse Box
7. ECU Main Relay
8. Fuel Pump Relay
9. Relay Box
10. Main Fuse 30 A
11. Starter Relay
12. Battery
13. Joint Connector A
14. Joint Connector C
15. Frame Ground
16. Fuel Pump
17. Air Switching Valve

3-90 FUEL SYSTEM (DFI)

Air Switching Valve (Service Code 64)

Air Switching Valve Circuit (Without Oxygen Sensor Equipped Models) (VN900C9 ~)

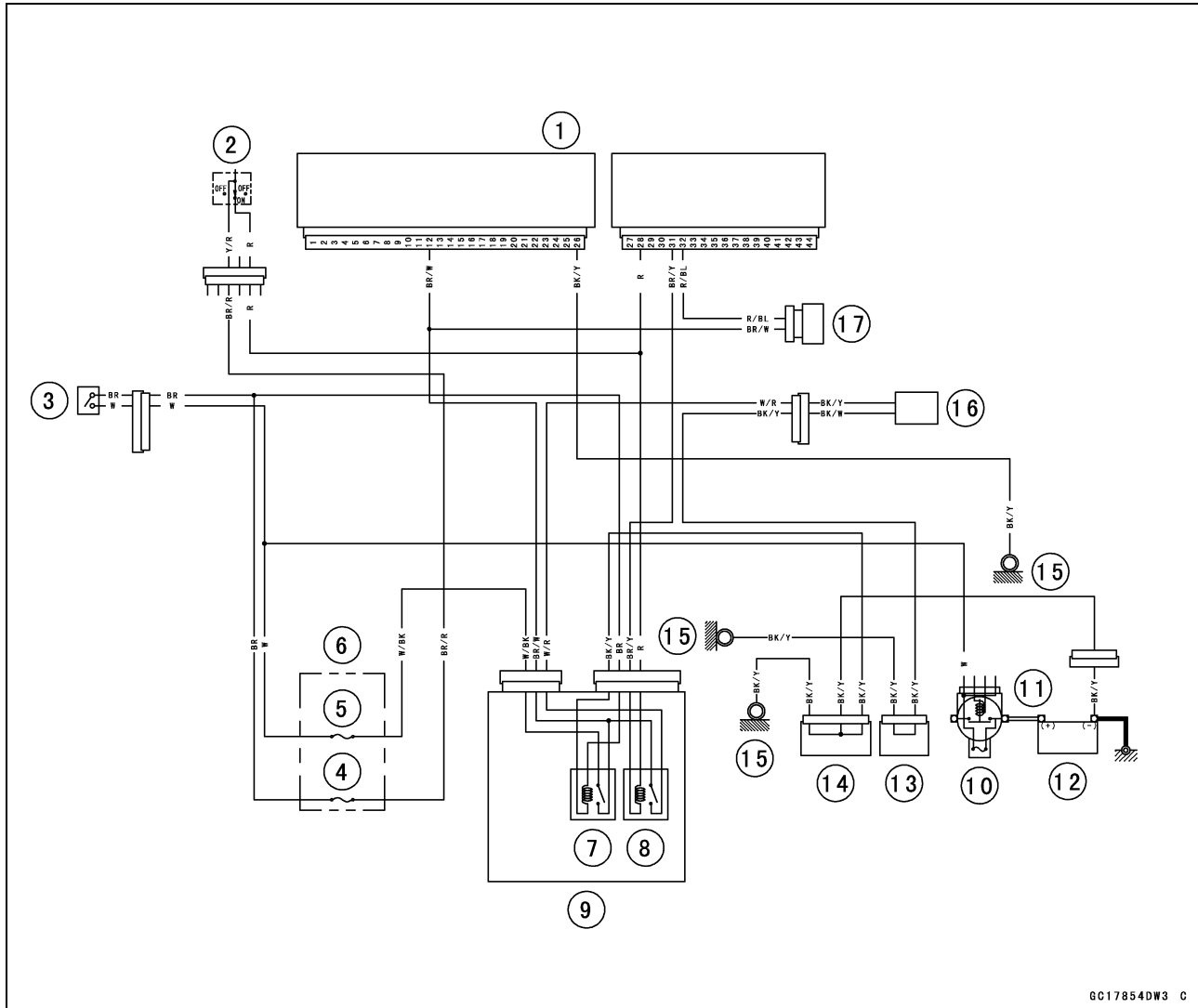

GC17854DW3 C

- 1. ECU
- 2. Engine Stop Switch
- 3. Ignition Switch
- 4. Ignition Fuse 10 A
- 5. ECU Fuse 15 A
- 6. Fuse Box
- 7. ECU Main Relay
- 8. Fuel Pump Relay
- 9. Relay Box
- 10. Main Fuse 30 A
- 11. Starter Relay
- 12. Battery
- 13. Joint Connector A
- 14. Joint Connector C
- 15. Frame Ground
- 16. Fuel Pump
- 17. Air Switching Valve

Air Switching Valve (Service Code 64)

Air Switching Valve Circuit
(Oxygen Sensor Equipped Models) (VN900C9 ~)

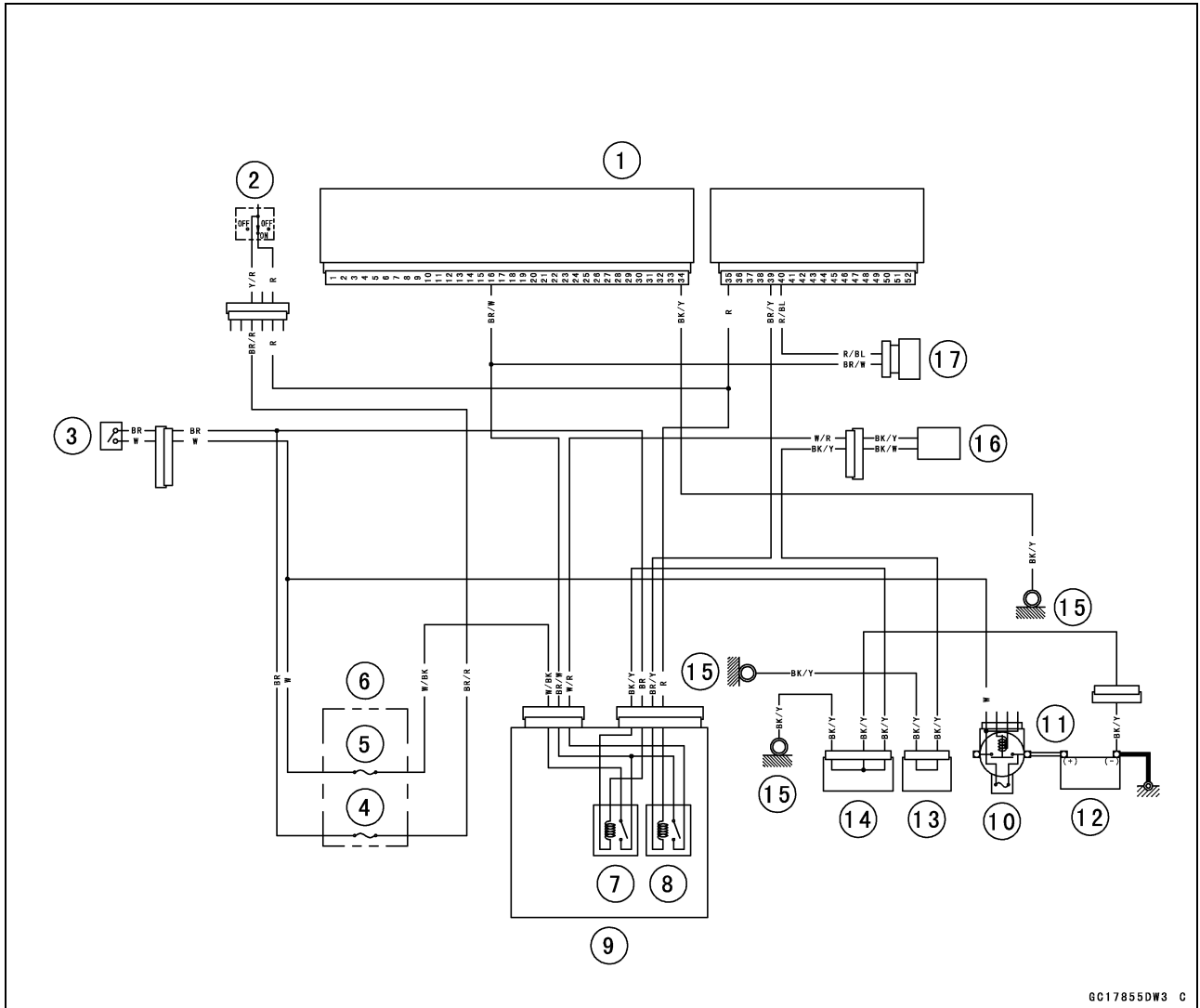

GC17855DW3 C

1. ECU
2. Engine Stop Switch
3. Ignition Switch
4. Ignition Fuse 10 A
5. ECU Fuse 15 A
6. Fuse Box
7. ECU Main Relay
8. Fuel Pump Relay
9. Relay Box
10. Main Fuse 30 A
11. Starter Relay
12. Battery
13. Joint Connector A
14. Joint Connector C
15. Frame Ground
16. Fuel Pump
17. Air Switching Valve

3-92 FUEL SYSTEM (DFI)

Oxygen Sensor Heaters #1, #2 (Service Code 67) (Oxygen Sensor Equipped Models)

Oxygen Sensor Heater Removal/Installation

The oxygen sensor heater is built in the oxygen sensor. So, the heater itself can not be removed. Remove the oxygen sensor (see Oxygen Sensor Removal in the Electrical System chapter).

Oxygen Sensor Heater Inspection

- Remove the right side cover (see Right Side Cover Removal in the Frame chapter).
- Disconnect the each oxygen sensor lead connectors [A].

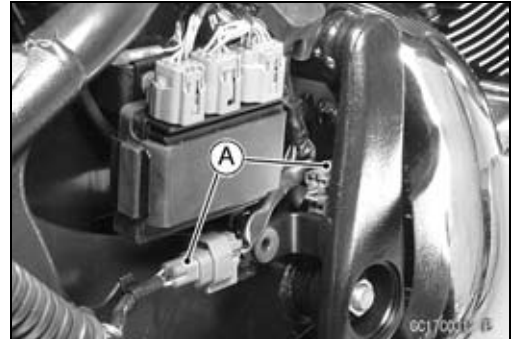

- Connect a digital meter to the terminals in the oxygen sensor lead connector [B].
White Lead Terminal [C]
White Lead Terminal [D]

Oxygen Sensor Resistance

Standard: About 8 Ω at 20°C (68°F)

- ★ If the meter reading is not as specified, replace the oxygen sensor with a new one.

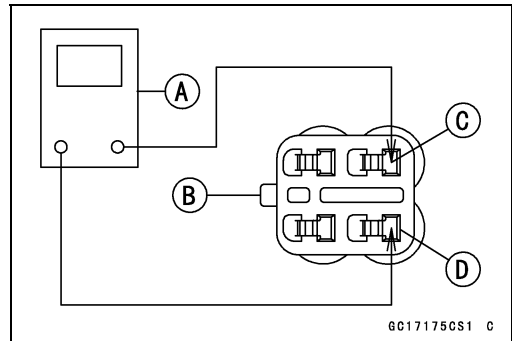

- ★ If the meter reading is specified, check the power source voltage inspection.

NOTE

○ Be sure the battery is fully charged.

- Connect a digital meter [A] to each oxygen sensor connector [B], using the needle adapter set [C].

Special Tool - Needle Adapter Set: 57001-1457

Oxygen Sensor Heaters Power Source Voltage Connections to Oxygen Sensor Connector

Meter (+) → W (main harness side P/BK) lead [D]

Meter (-) → Battery (-) Terminal [E]

Oxygen Sensor #1 [F]

Oxygen Sensor #2 [G]

- Measure the power source voltage with the engine stopped, and with the oxygen sensor connector joined.
- Turn the ignition switch ON.

Power Source Voltage at Sensor Connector

Standard: Battery Voltage

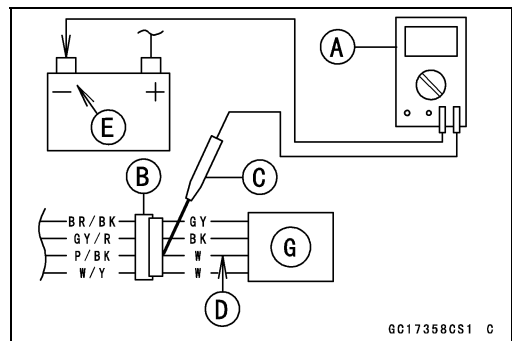
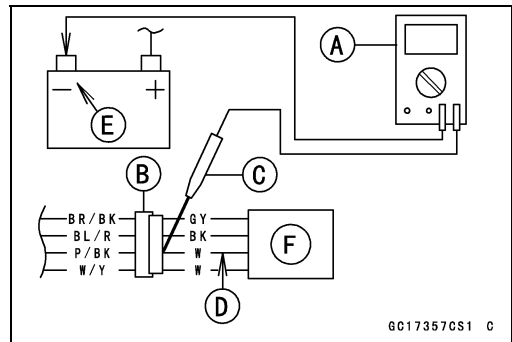

Oxygen Sensor Heaters #1, #2 (Service Code 67) (Oxygen Sensor Equipped Models)

- ★ If the reading is incorrect, check the following.
 - Battery (see Charging Condition Inspection in the Electrical System chapter)
 - Main Fuse 30 A (see Fuse Inspection in the Electrical System chapter)
 - Oxygen Sensor Heater Fuse 10 A (see Fuse Inspection in the Electrical System chapter)
- ★ If the reading is good, the power source voltage is normal, inspect the red lead between the oxygen sensor connector and the ECU for continuity, using the following diagram.
- ★ If the wiring is good, inspect the ECU for its ground, and power supply (see ECU Power Supply Inspection). If the ground and power supply are good, replace the ECU.
- Remove the needle adapter set, and apply silicone sealant to the connector for waterproofing.
 - Sealant - Liquid Gasket, TB1211: 56019-120

Oxygen Sensor Circuit (VN900C7 ~ C8)

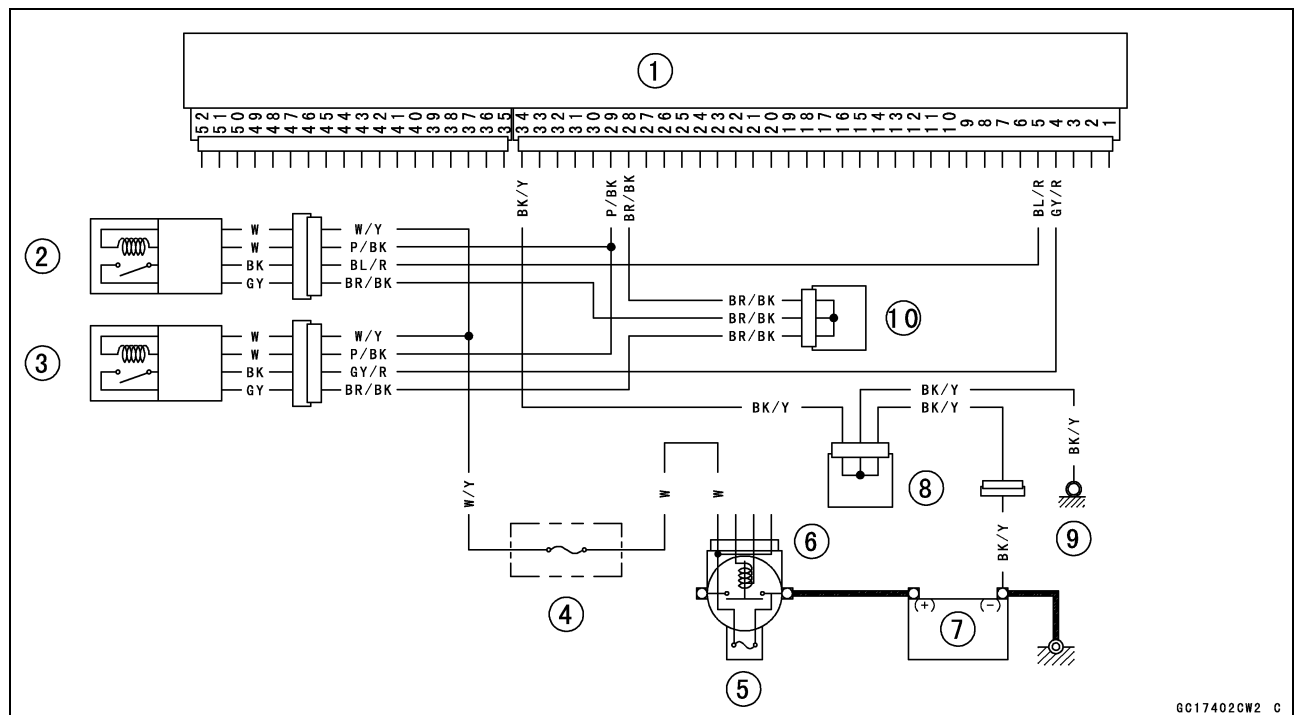

1. ECU
2. Oxygen Sensor #1
3. Oxygen Sensor #2
4. Oxygen Sensor Heater Fuse 10 A
5. Main Fuse 30 A
6. Starter Relay
7. Battery
8. Joint Connector C
9. Frame Ground
10. Joint Connector B

3-94 FUEL SYSTEM (DFI)

Oxygen Sensor Heaters #1, #2 (Service Code 67) (Oxygen Sensor Equipped Models)

Oxygen Sensor Circuit (VN900C9 ~)

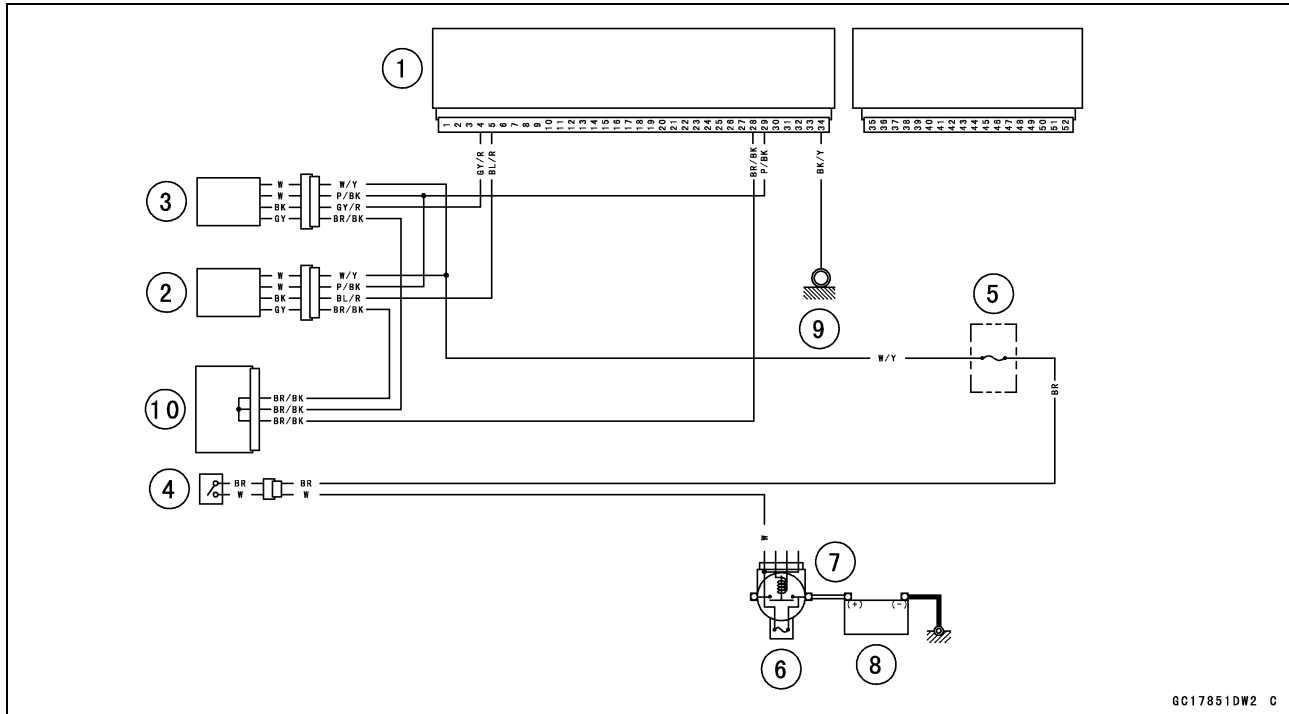

GC178510W2 C

1. ECU
2. Oxygen Sensor #1
3. Oxygen Sensor #2
4. Ignition Switch
5. Oxygen Sensor Heater Fuse 10 A
6. Main Fuse 30 A
7. Starter Relay
8. Battery
9. Frame Ground
10. Joint Connector B

Oxygen Sensors-Incorrect Output Voltage #1, #2 (Service Code 94, 95) (Oxygen Sensor Equipped Models)

Oxygen Sensor #1: Service Code 94
 Oxygen Sensor #2: Service Code 95

Oxygen Sensor Removal/Installation

- Refer to the Oxygen Sensor Removal and Installation in the Electrical System chapter.

Oxygen Sensor Inspection

NOTE

- The oxygen sensor itself is the same for #1 [A] and #2 [B], but wiring of the main harness side is different.

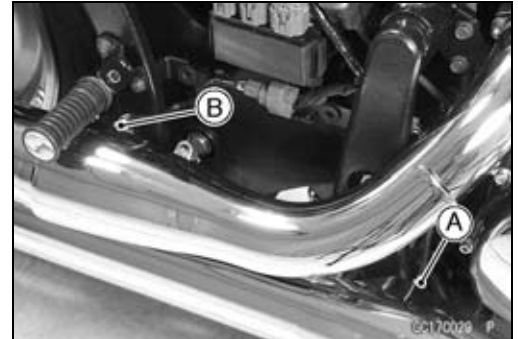

- Warm up the engine thoroughly.
- Turn the ignition switch OFF.
- Remove the right side cover (see Right Side Cover Removal in the Frame chapter).
- Connect a digital voltmeter [A] to the each oxygen sensor connector [B] (sensor side), using the needle adapter set.

Special Tool - Needle Adapter Set: 57001-1457

Oxygen Sensor Output Voltage

Connections to Oxygen Sensor Connector

- Meter (+) → BK lead**
- Meter (-) → GY lead**

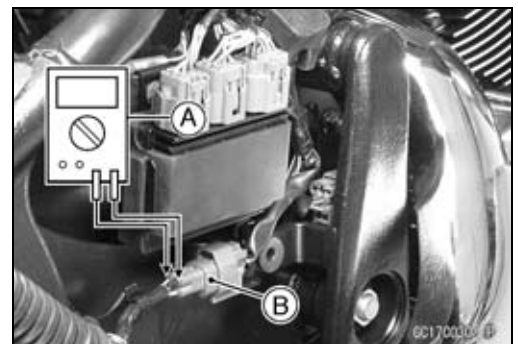

- Disconnect the air switching valve hoses [A] (both sides) from the fittings.



- Install the suitable plugs [A] (both sides) on the fittings and shut off the secondary air.
- Turn the ignition switch ON.
- Start the engine, and let it idle.
- Measure the output voltage of the sensor with the connector joined.

Oxygen Sensor Output Voltage (with Plugs)

Standard: 0.45 ~ 2.5 V



3-96 FUEL SYSTEM (DFI)

Oxygen Sensors-Incorrect Output Voltage #1, #2 (Service Code 94, 95) (Oxygen Sensor Equipped Models)

- Next, remove the plugs [A] (both sides) from the fittings with idling.
- Measure the output voltage of the sensor with the connector joined.

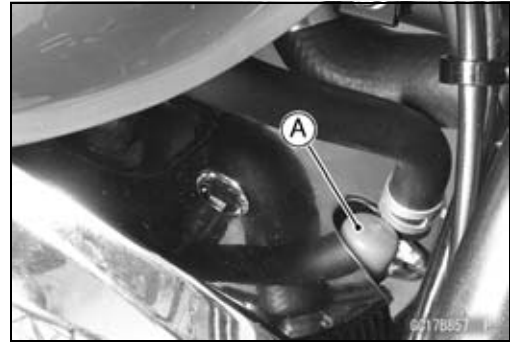

Oxygen Sensor Output Voltage (without Plugs)

Standard: 0.05 ~ 0.45 V

- ★ If the reading is within range (with plugs: 0.45 ~ 2.5 V, without plugs: 0.05 ~ 0.45 V), the oxygen sensor is good.
- ★ If the reading is without range, inspect the engine and fuel supply system.
- ★ If the engine and fuel supply system good, replace the oxygen sensor.
- Remove the needle adapter set, and apply silicone sealant to the seals of the connector for waterproofing.

Sealant - Liquid Gasket, TB1211: 56019-120

Oxygen Sensor Circuit (VN900C7 ~ C8)

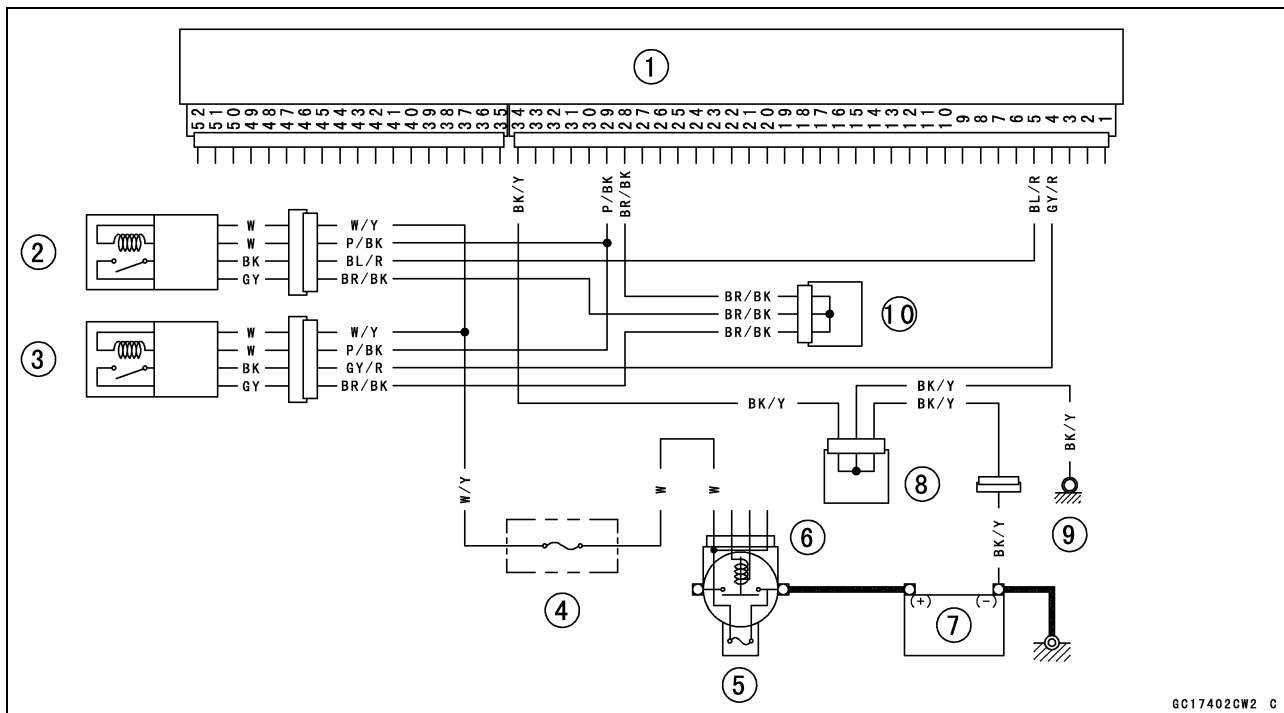

1. ECU
2. Oxygen Sensor #1
3. Oxygen Sensor #2
4. Oxygen Sensor Heater Fuse 10 A
5. Main Fuse 30 A
6. Starter Relay
7. Battery
8. Joint Connector C
9. Frame Ground
10. Joint Connector B

Oxygen Sensors-Incorrect Output Voltage #1, #2 (Service Code 94, 95) (Oxygen Sensor Equipped Models)

Oxygen Sensor Circuit (VN900C9 ~)

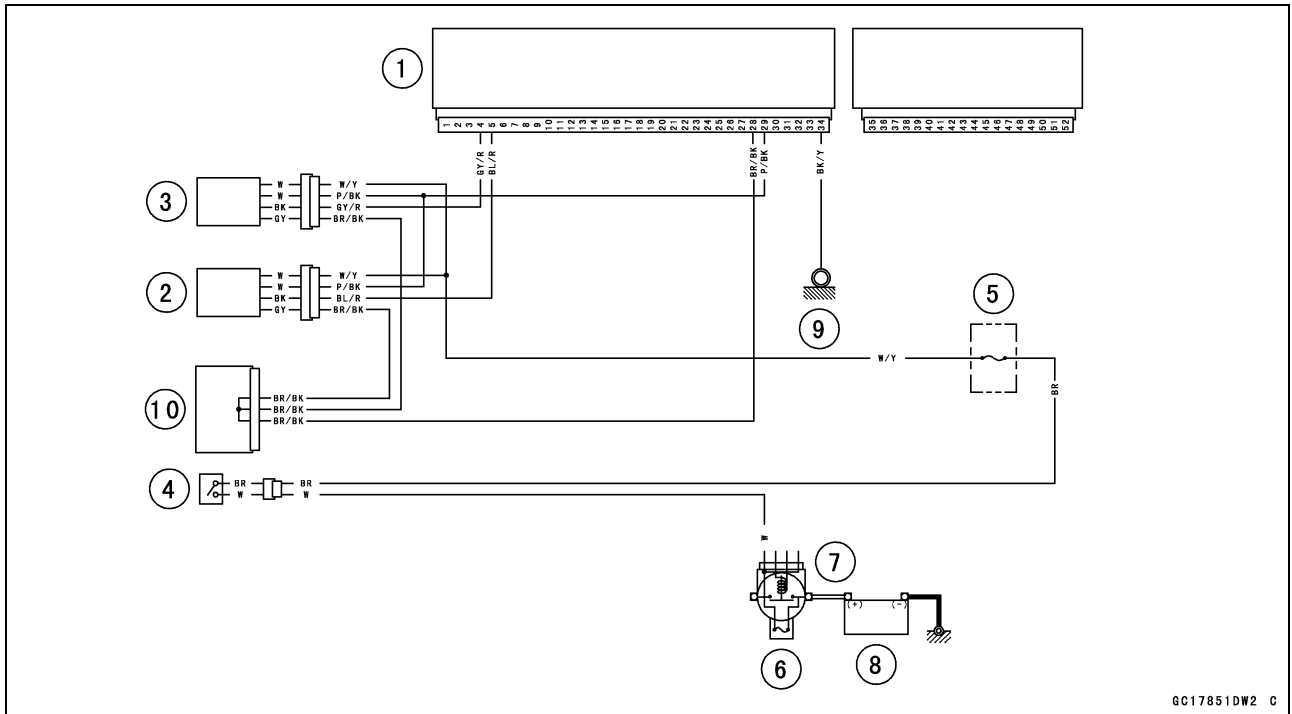

GC17851DW2 C

1. ECU
2. Oxygen Sensor #1
3. Oxygen Sensor #2
4. Ignition Switch
5. Oxygen Sensor Heater Fuse 10 A
6. Main Fuse 30 A
7. Starter Relay
8. Battery
9. Frame Ground
10. Joint Connector B

3-98 FUEL SYSTEM (DFI)

FI Indicator Light (LED)

Inspection Flow Chart

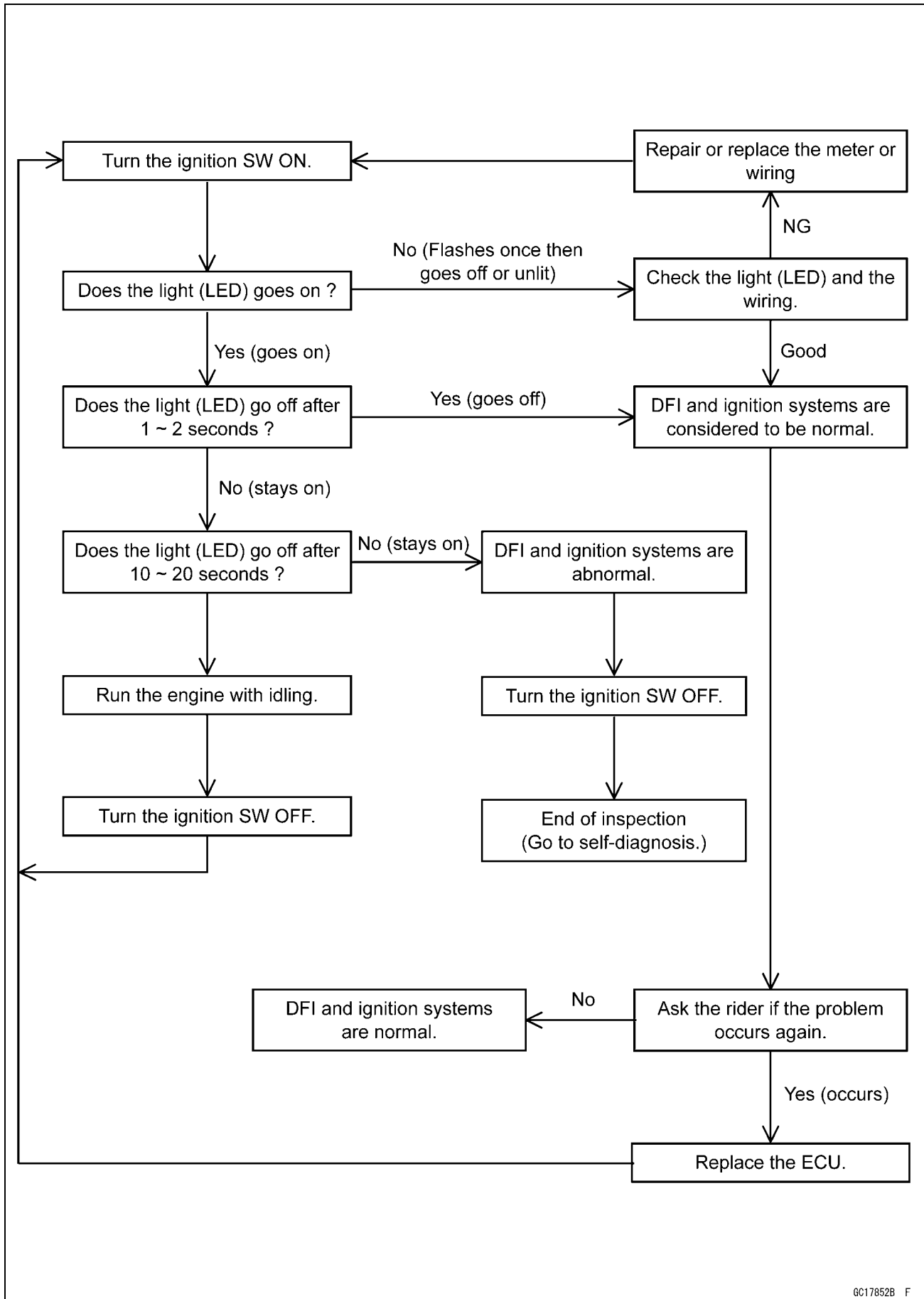

FI Indicator Light (LED)

Light (LED) Inspection

- The FI indicator light (LED) [A] goes ON when the ignition switch is turned ON and the LED light goes OFF when the engine oil pressure is high enough (the engine is running). This is to ensure that the FI indicator light (LED) has not burned out and the DFI system and the ignition system function properly.
- Refer to the Meter Unit Inspection in the Electrical System chapter for LED and Indicator Light Inspection.
- ★ If the light (LED) is abnormal, replace the meter unit.
- ★ If the FI indicator light (LED) is normal, the wiring or ECU has trouble. Check the wiring (see next diagram). If the wiring is good, check the ECU for its ground and power supply (see ECU Power Supply Inspection).



3-100 FUEL SYSTEM (DFI)

FI Indicator Light (LED)

FI Indicator Light (LED) Circuit (Without Oxygen Sensor Equipped Models) (VN900C7 ~ C8)

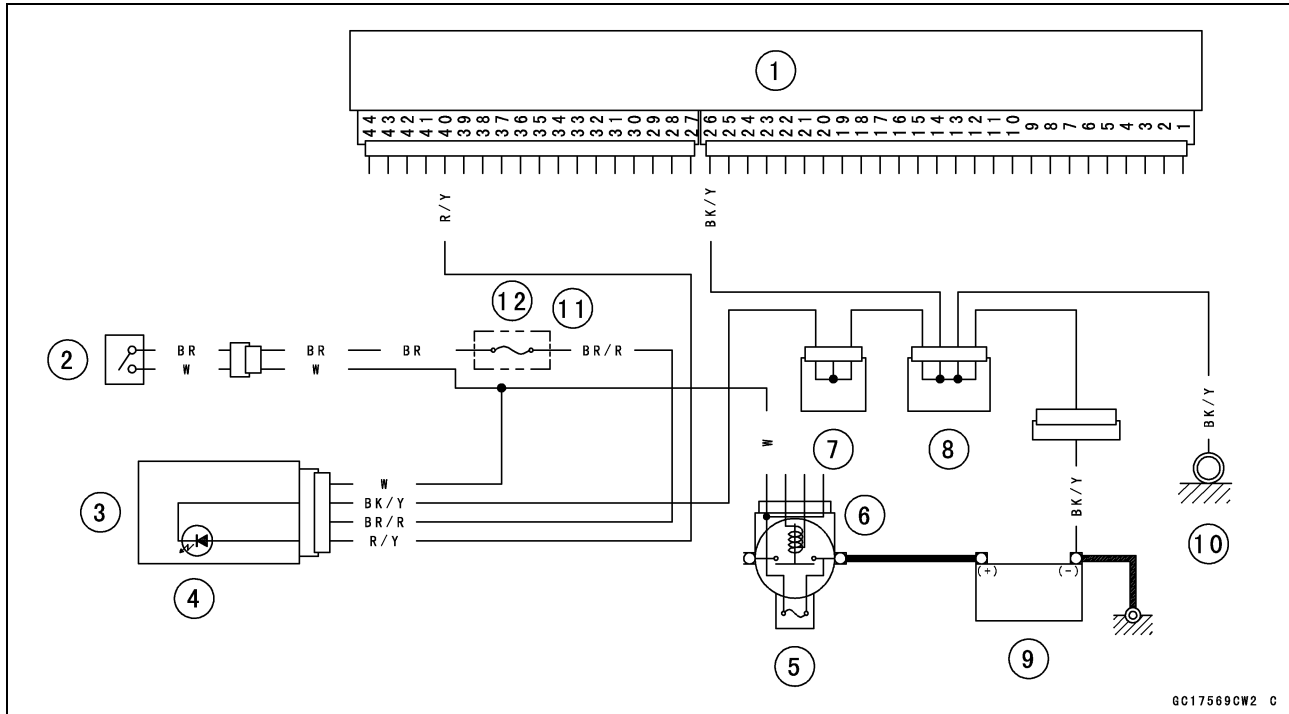

GC17569CW2 C

FI Indicator Light (LED) Circuit (Oxygen Sensor Equipped Models) (VN900C7 ~ C8)

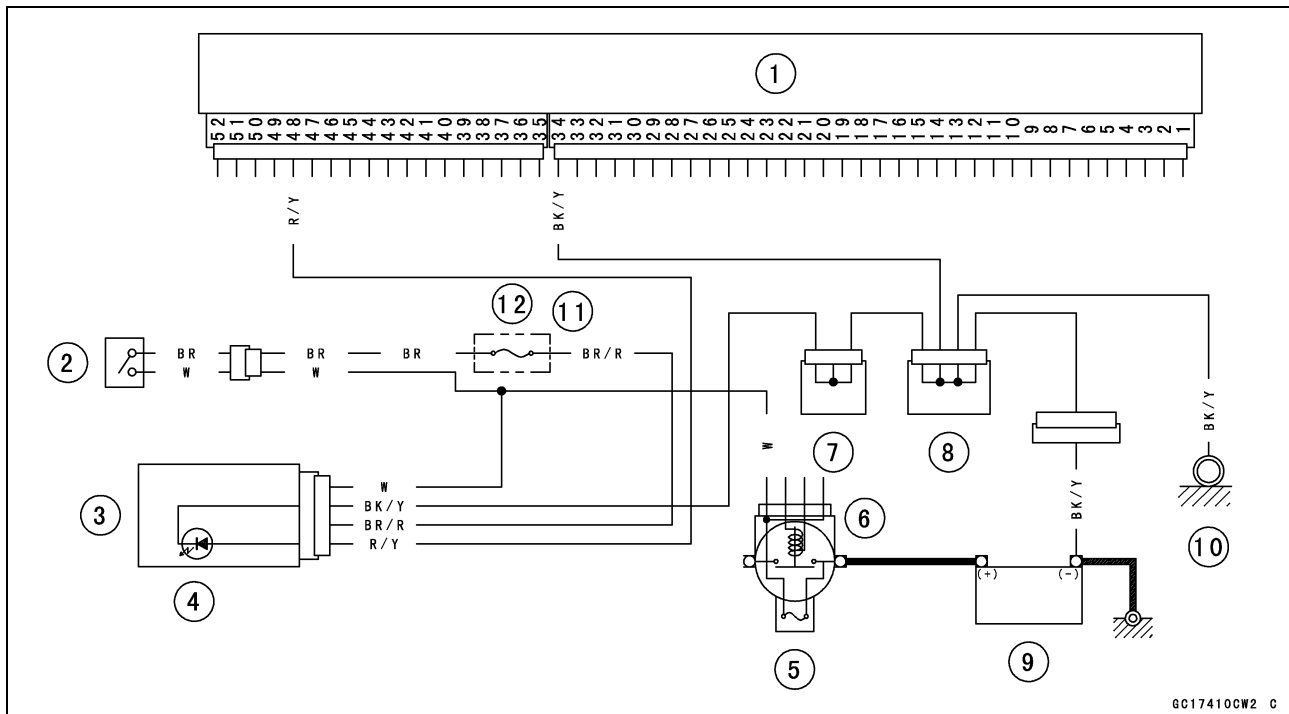

GC17410CW2 C

- | | |
|-----------------------------|------------------------|
| 1. ECU | 7. Joint Connector A |
| 2. Ignition Switch | 8. Joint Connector C |
| 3. Meter Unit | 9. Battery |
| 4. FI Indicator Light (LED) | 10. Frame Ground |
| 5. Main Fuse 30 A | 11. Fuse Box |
| 6. Starter Relay | 12. Ignition Fuse 10 A |

FI Indicator Light (LED)

FI Indicator Light (LED) Circuit
(Without Oxygen Sensor Equipped Models) (VN900C9 ~)

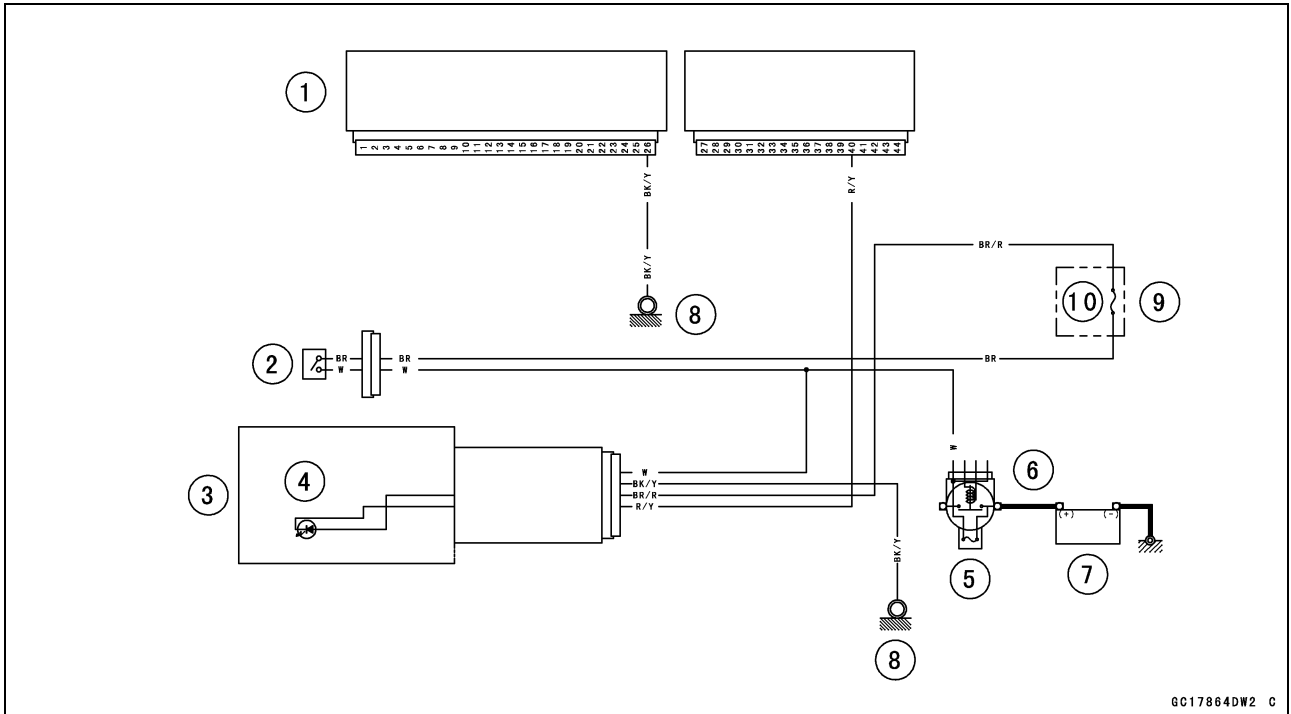

FI Indicator Light (LED) Circuit
(Oxygen Sensor Equipped Models) (VN900C9 ~)

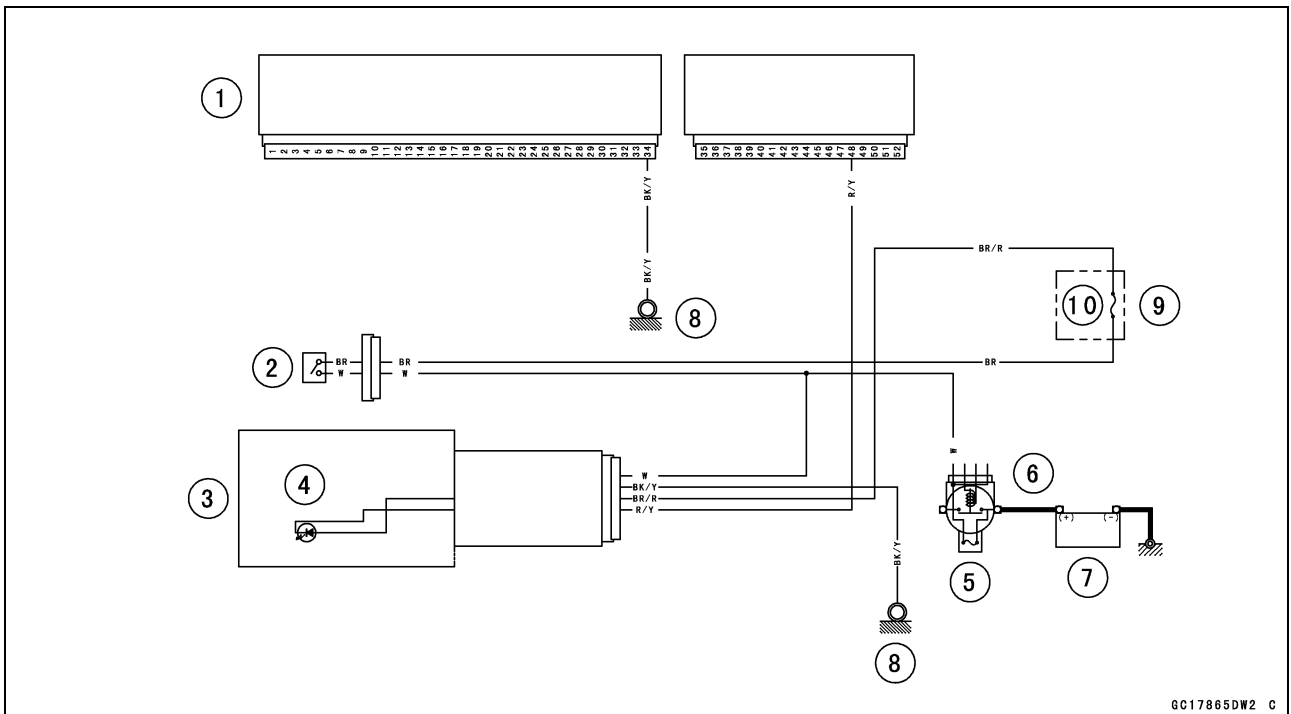

1. ECU
2. Ignition Switch
3. Meter Unit
4. FI Indicator Light (LED)
5. Main Fuse 30 A

6. Starter Relay
7. Battery
8. Frame Ground
9. Fuse Box
10. Ignition Fuse 10 A

3-102 FUEL SYSTEM (DFI)

ECU

ECU Removal

NOTICE

Never drop the ECU, especially on a hard surface. Such a shock to the ECU can damage it.

- Remove:
 - Seat (see Seat Removal in the Frame chapter)
 - Tool Box (see Tool Box Removal in the Frame chapter)
- Pull out the ECU [A] along with the harness.
- ★ If necessary, push the lock and disconnect the ECU connectors.

ECU Installation

- Connect the ECU connectors [A].
- Fit the ECU [A] in the battery case.
- Install the removed parts (see appropriate chapters).

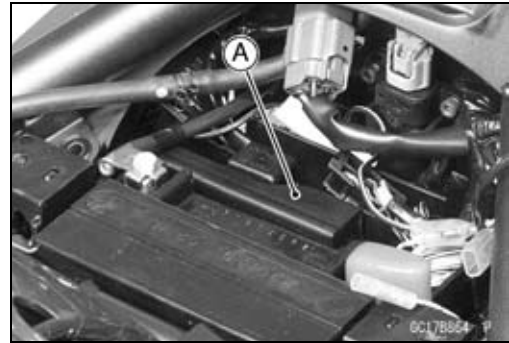

ECU Power Supply Inspection

- Visually inspect the terminals of the ECU connector.
- ★ If the connector is clogged with mud or dust, blow it off with compressed air.
- ★ Replace the main harness if the terminals [A] of the main harness connectors are cracked, bent, or otherwise damaged.
- ★ Replace the ECU if the terminals of the ECU connector are cracked, bent, or otherwise damaged.



- With the ECU connector joined, check the following ground leads for continuity with the ignition switch ON or OFF, using a digital voltmeter.

ECU Grounding Inspection

Meter Connections:

(Without Oxygen Sensor Equipped Models [A])

- 26, 42, 43 (BK/Y) Terminal ↔ Battery (-) Terminal
- 22 (BR/BK) Terminal ↔ Battery (-) Terminal
- Engine Ground ↔ Battery (-) Terminal

(Oxygen Sensor Equipped Models [B])

- 34, 50, 51 (BK/Y) Terminal ↔ Battery (-) Terminal
- 28 (BR/BK) Terminal ↔ Battery (-) Terminal
- Engine Ground ↔ Battery (-) Terminal

Readings: 0 Ω (regardless of the ignition switch ON or OFF)

- ★ If no continuity, check the connector, the engine ground lead, or main harness, and repair or replace them if necessary.

Special Tool - Needle Adapter Set: 57001-1457

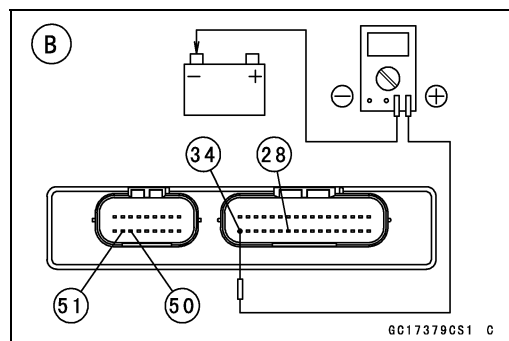
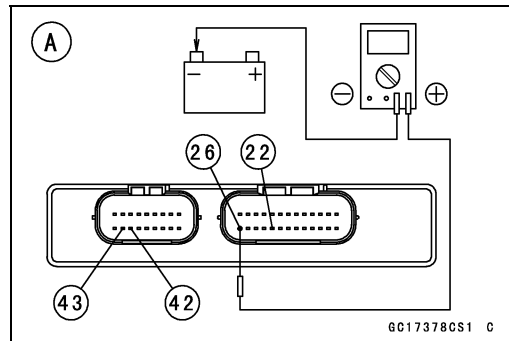

ECU

- Check the ECU power source voltage with a digital meter.
- Position the terminal in accordance with terminal numbers of ECU connectors as shown in the figure.

ECU Power Source Inspection

Meter Connections:

(Without Oxygen Sensor Equipped Models [A])

Between Terminal 12 (BR/W) and Battery (-) Terminal

Between Terminal 27 (W/BK) and Battery (-) Terminal

Ignition Switch OFF:

Terminal 12 (BR/W): 0 V

Terminal 27 (W/BK): Battery Voltage (12.8 V or more)

Ignition Switch ON:

Both: Battery Voltage (12.8 V or more)

(Oxygen Sensor Equipped Models [B])

Between Terminal 16 (BR/W) and Battery (-) Terminal

Between Terminal 17 (W/BK) and Battery (-) Terminal

Ignition Switch OFF:

Terminal 16 (BR/W): 0 V

Terminal 17 (W/BK): Battery Voltage (12.8 V or more)

Ignition Switch ON:

Both: Battery Voltage (12.8 V or more)

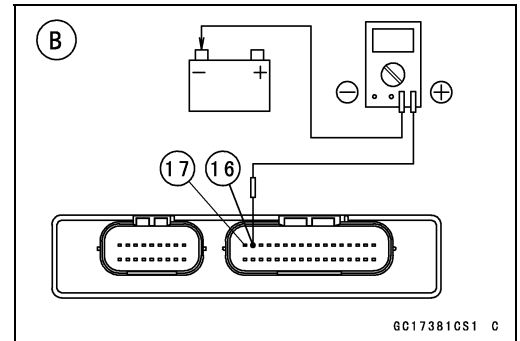
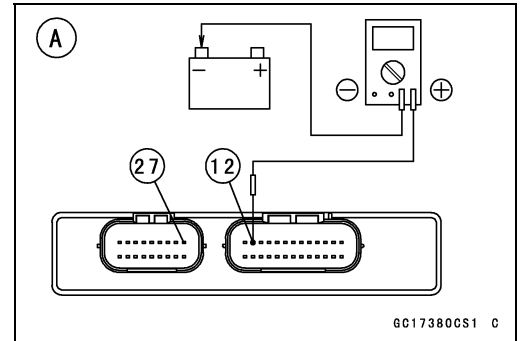

3-104 FUEL SYSTEM (DFI)

Fuel Line

Fuel Pressure Inspection

NOTE

- This inspection can determine which trouble the DFI system has, mechanical or electrical trouble.
- It is preferable to measure the fuel pressure while running the motorcycle when the trouble has occurred in order to know symptom well.
- Be sure the battery is fully charged.
- Remove the fuel tank (see Fuel Tank Removal).
- Pull the fuel hose joint out of the delivery pipe (see Fuel Tank Removal).

⚠ WARNING

Fuel is flammable and explosive under certain conditions and can cause severe burns. Be prepared for fuel spillage; any spilled fuel must be completely wiped up immediately. When the fuel hose is disconnected, fuel spills out from the hose and the pipe. Cover the hose connection with a clean shop towel to prevent fuel spillage.

- Install the fuel pressure gauge adapter [A] between the fuel tank outlet pipe [B] and the inlet pipe [C] to the delivery joint [D].
 - Put the fuel pressure gauge adapter outside the frame.
 - Connect the pressure gauge [E] to the fuel pressure gauge adapter.
- Fuel Tank [F]
Fuel Pump [G]
Front [H]
→: Fuel Flow

Special Tools - Oil Pressure Gauge: 57001-125
Fuel Pressure Gauge Adapter: 57001-1593
Fuel Hose: 57001-1607

⚠ WARNING

Fuel is extremely flammable and can be explosive under certain conditions resulting in serious injury or death. Do not try to start the engine with the fuel hoses disconnected.

- Turn the ignition switch ON. The fuel pump will turn for 3 seconds, and then stop.

NOTE

- Turn the ignition switch ON and inspect the fuel line leakage after installing the special tools.

NOTICE

Do not drive the fuel pump 3 seconds or more without the fuel in the fuel tank. If the fuel pump is driven without the fuel, it may be damaged.

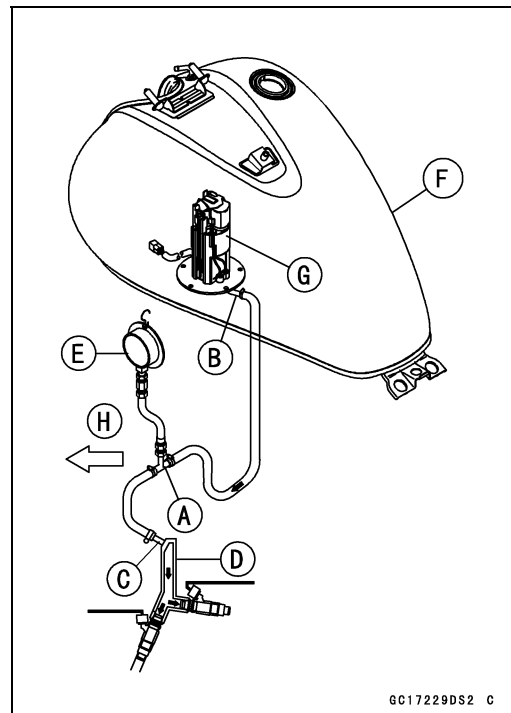

Fuel Line

- Start the engine, and let it idle.
- Measure the fuel pressure with the engine idling.

Fuel Pressure (Idling)

Standard: 294 kPa (3.0 kgf/cm², 43 psi)

NOTE

○ *The gauge needle will fluctuate. Read the pressure at the average of the maximum and minimum indications.*

- ★ If the fuel pressure is much higher than the specified, the fuel pressure regulator in the fuel pump have been clogged or stuck. Replace the fuel pump (see Fuel Pump Removal/Installation).
- ★ If the fuel pressure is much lower than the specified, check the following.
 - Fuel Line Leakage
 - Amount of Fuel Flow (see Fuel Flow Rate Inspection)
- ★ If the fuel pressure is much lower than specified, and if inspection above checks out good, replace the throttle body assy or the fuel pump and measure the fuel pressure again.
- Remove the fuel pressure gauge, fuel hoses and adapter.
- Install the fuel hose joint (see Fuel Tank Installation).
- Run the fuel hose correctly (see Cable, Wire, and Hose Routing section in the Appendix chapter).
- Install the fuel tank (see Fuel Tank Installation).

Fuel Flow Rate Inspection

NOTE

○ *Be sure the battery is fully charged.*

⚠ WARNING

Gasoline is extremely flammable and can be explosive under certain conditions, creating the potential for serious burns. Make sure the area is well-ventilated and free from any source of flame or sparks; this includes any appliance with a pilot light. Do not smoke. Turn the ignition switch OFF. Be prepared for fuel spillage; any spilled fuel must be completely wiped up immediately.

- Turn both ignition switch, and engine stop switch OFF.
- Wait until the engine cools down.
- Open the fuel tank cap [A] to lower the pressure in the tank.

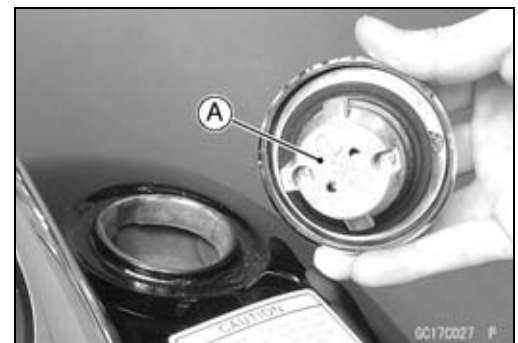

3-106 FUEL SYSTEM (DFI)

Fuel Line

- Prepare a fuel hose of the inside diameter 7.5 mm (0.30 in.) and a measuring cylinder.
- Remove:
 - Seat (see Seat Removal in the Frame chapter)
 - Fuel Tank Bolts (see Fuel Tank Removal)
- Raise the fuel tank.
- Stuff a clean shop towel around the fuel outlet hose joint.
- While pinching the locks of the hose joint with fingers, disconnect the joint (see Fuel Tank Removal) and insert the fuel hose [A] quickly onto the tank outlet pipe.
- Secure the fuel hose with a clamp [B].
- Run the other side of the fuel hose into the measuring cylinder [C].
- Temporarily install the fuel tank and close the fuel tank cap.

⚠ WARNING

**Wipe off spilled out fuel immediately.
Be sure to hold the measuring cylinder vertical.**

- With the engine stopped, turn the ignition switch ON. The fuel pump should operate for 3 seconds, and then should stop. Repeat this several times until the fuel hose is filled with fuel.
- Measure the discharge for 3 seconds with the fuel hose filled with fuel.

Amount of Fuel Flow

Standard: 50 mL (1.7 US oz.) or more for 3 seconds

- ★ If the fuel flow is much less than the specified, check the battery condition (see Charging Condition Inspection in the Electrical System chapter). If the battery is good, replace the fuel pump.
- After inspection, connect the fuel hoses, and install the fuel tank (see Fuel Tank Installation).
- Start the engine and check for no fuel leakage.

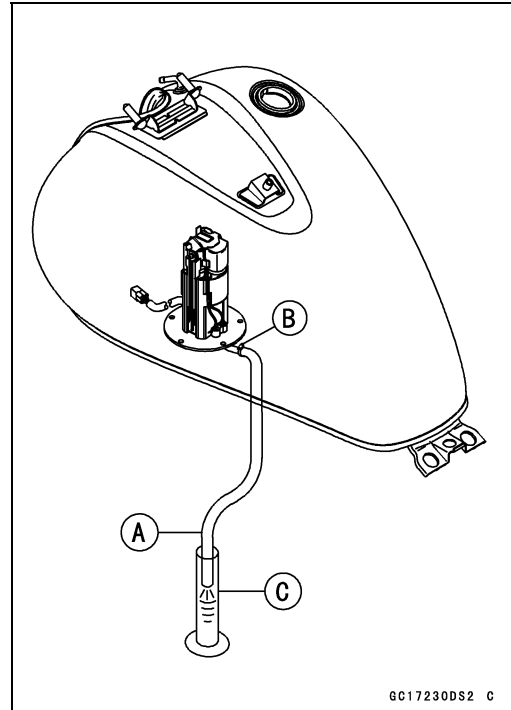

Fuel Pump

Fuel Pump Removal

NOTICE

Never drop the fuel pump, especially on a hard surface. Such a shock to the pump can damage it.

⚠ WARNING

Gasoline is extremely flammable and can be explosive under certain conditions, creating the potential for serious burns. Make sure the area is well-ventilated and free from any source of flame or sparks; this includes any appliance with a pilot light. Do not smoke. Turn the ignition switch OFF. Disconnect the battery (-) terminal. To avoid fuel spills, draw it from the tank when the engine is cold. Be prepared for fuel spillage; any spilled fuel must be completely wiped up immediately.

- Remove the fuel tank (see Fuel Tank Removal).
- Be careful of fuel spillage from the fuel tank since fuel still remains in the fuel tank and fuel pump. Plug the fuel pipe of the fuel tank.
- Turn the fuel tank upside down.
- Unscrew the fuel pump bolts [A], and take out the fuel pump [B] and gasket.
- Discard the fuel pump gasket.

NOTICE

Do not pull the leads [C] of the fuel pump. If they are pulled, the lead terminals may be damaged.

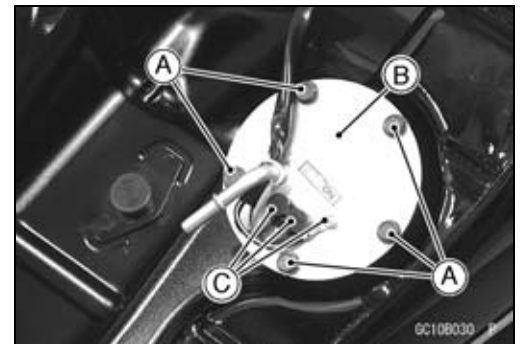

Fuel Pump Installation

- Remove dirt or dust from the fuel pump [A] by lightly applying compressed air.

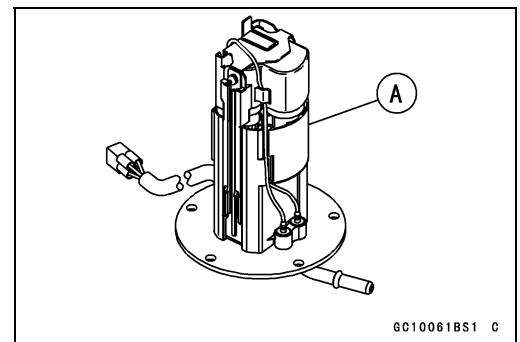

- Replace the fuel pump gasket [A] with a new one.

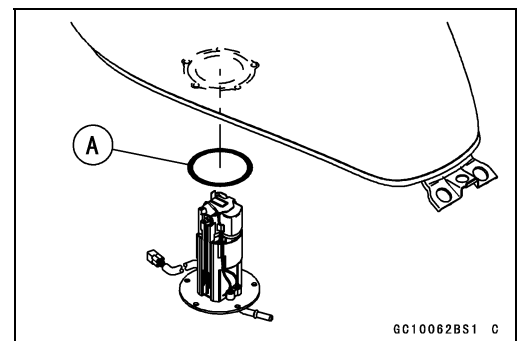

3-108 FUEL SYSTEM (DFI)

Fuel Pump

- Check that the terminals [A] and band [B] are in place.
- Apply a non-permanent locking agent to the threads of the fuel pump bolts.
- Tighten the fuel pump bolts [C] to a snug fit.
- Tighten:

Torque - Fuel Pump Bolts: 9.8 N·m (1.0 kgf·m, 87 in·lb)

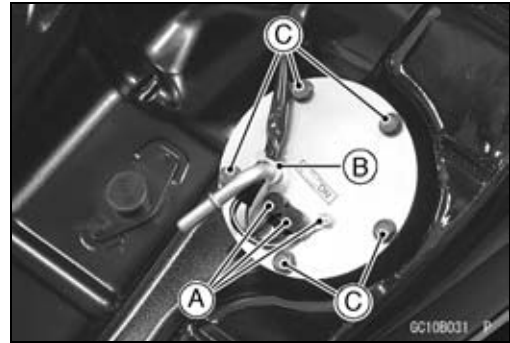

Pump Screen, Fuel Filter Cleaning

- The pump screen [A] and fuel filter [B] are built into the pump and cannot be cleaned or checked.
- ★ If the pump screen or fuel filter is suspected of clogging or being damaged, replace it with the fuel pump as a set.

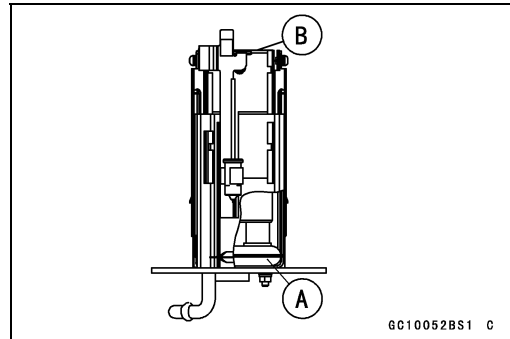

Fuel Pump Operation Inspection

NOTE

- Be sure the battery is fully charged.
- Just listen to the pump sound in the fuel tank to confirm pump operation.
- Turn the ignition switch ON and make sure that the fuel pump operates (make light sounds) for 3 seconds, and then stops.
- Turn the ignition switch OFF.
- ★ If the pump does not work as described above, inspect the power source voltage.

Fuel Pump

Fuel Pump Operating Voltage Inspection

NOTE

○Be sure the battery is fully charged.

- Turn the ignition switch OFF.
- Remove the ignition coil cover (see Ignition Coil Removal in the Electrical System chapter).
- Connect a tester to the fuel pump connector [A] with needle adapter set.

Special Tool - Needle Adapter Set: 57001-1457

- Measure the operating voltage with the engine stopped, and with the connector joined.
- Turn the ignition switch ON.
- The tester needle should indicate battery voltage for 3 seconds, and then 0 V.

Pump Operating Voltage at Pump

Connections to Pump Connectors

Tester (+) → BK/Y Lead

Tester (-) → BK/W Lead

Operating Voltage at Pump Connector

Standard: Battery Voltage (12.8 V or more) for 3 seconds, and then 0 V

- ★ If the reading stays on battery voltage, and never shows 0 V. Check the ECU and fuel pump relay.
- ★ If the voltage is in specification, but the pump doesn't work, replace the pump.
- ★ If there is still no battery voltage, check the pump relay (see Relay Circuit Inspection in the Electrical System chapter).

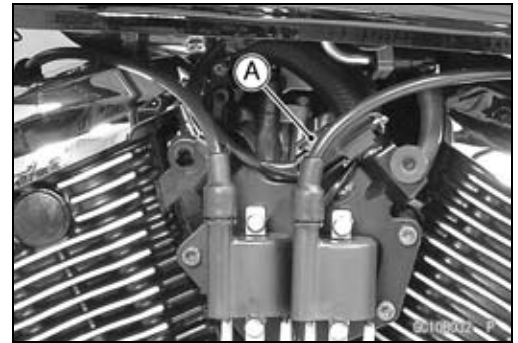

3-110 FUEL SYSTEM (DFI)

Fuel Pump

Fuel Pump Power Source Voltage Inspection

NOTE

○Be sure the battery is fully charged.

- Remove the ignition coil cover (see Ignition Coil Removal in the Electrical System chapter).
- Connect a digital meter [A] to the fuel pump connector [B] (3P), using the needle adapter set [C].

Special Tool - Needle Adapter Set: 57001-1457

- Measure the power source voltage with the engine stopped, and with the pump connector joined.
- Turn the ignition switch ON.

Pump Power Source Voltage

Connections to Pump Connector

Meter (+) → BK/Y lead [D]

Meter (-) → Battery (-) Terminal [E]

Standard: Battery Voltage (12.8 V or more)

Fuel Pump [F]

- ★ If the reading is good, the power source voltage is normal. Inspect operating source voltage (see Fuel Pump Operating Voltage Inspection).
- ★ If the reading is incorrect, check the following.
 - Battery (see Charging Condition Inspection in the Electrical System chapter)
 - Main Fuse 30 A (see Fuse Inspection in the Electrical System chapter)
 - Ignition Fuse 10 A (see Fuse Inspection in the Electrical System chapter)
 - Fuel Pump Relay (see Relay Circuit Inspection in the Electrical System chapter)
 - Wiring for Fuel Pump Power Source (see next diagram)
 - Vehicle-down Sensor (see Vehicle-down Sensor Inspection)

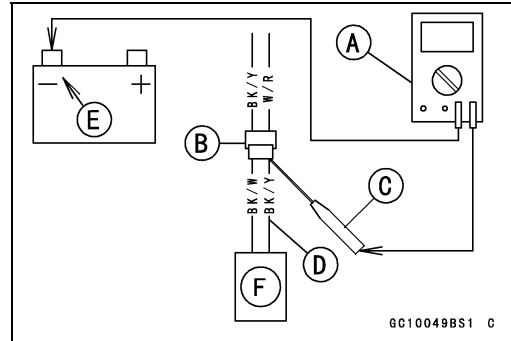

Fuel Pump

Fuel Pump Circuit
(Without Oxygen Sensor Equipped Models) (VN900C7 ~ C8)

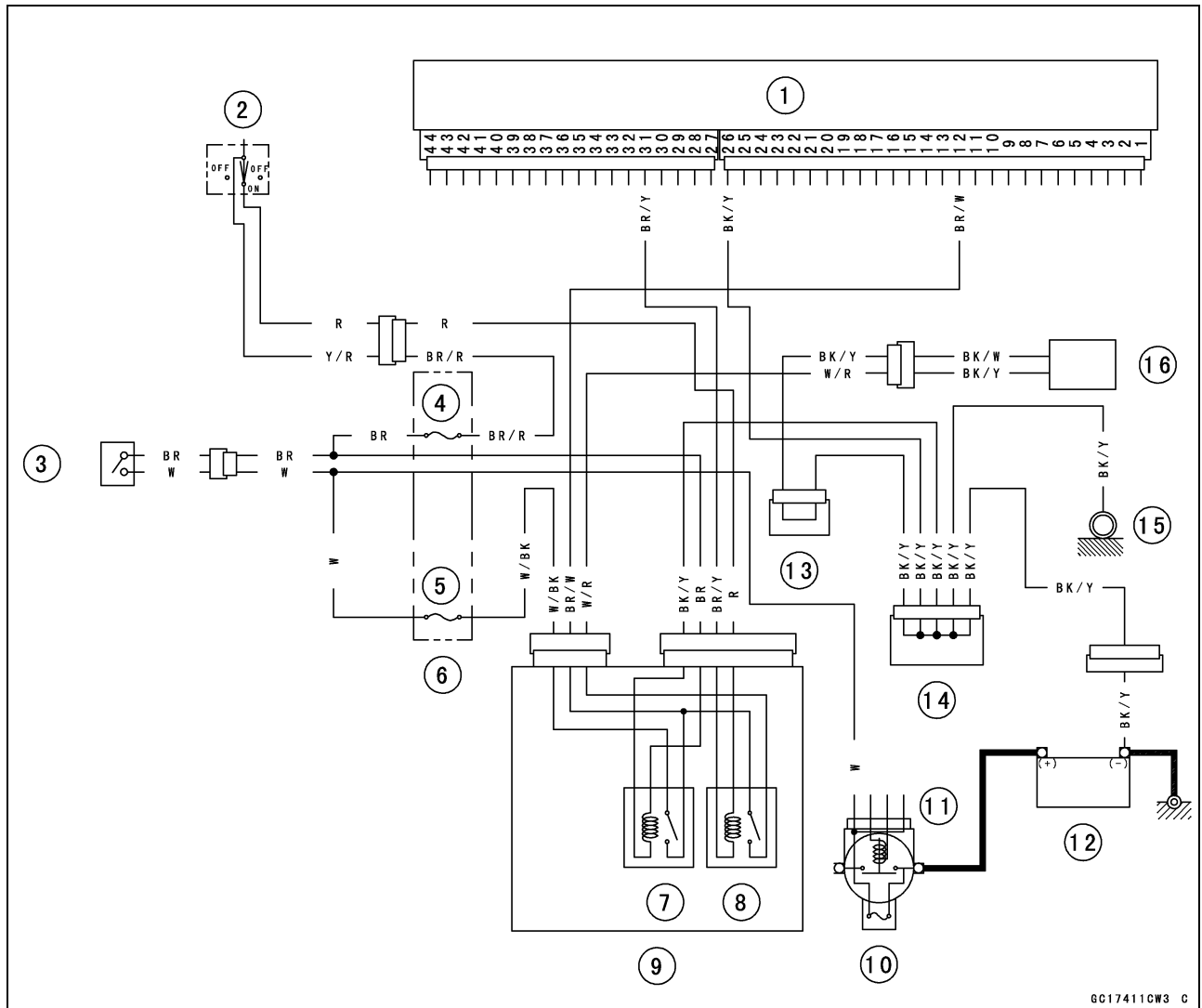

GC17411CW3 C

1. ECU
2. Engine Stop Switch
3. Ignition Switch
4. Ignition Fuse 10 A
5. ECU Fuse 15 A
6. Fuse Box
7. ECU Main Relay
8. Fuel Pump Relay
9. Relay Box
10. Main Fuse 30 A
11. Starter Relay
12. Battery
13. Joint Connector A
14. Joint Connector C
15. Frame Ground
16. Fuel Pump

3-112 FUEL SYSTEM (DFI)

Fuel Pump

Fuel Pump Circuit (Oxygen Sensor Equipped Models) (VN900C7 ~ C8)

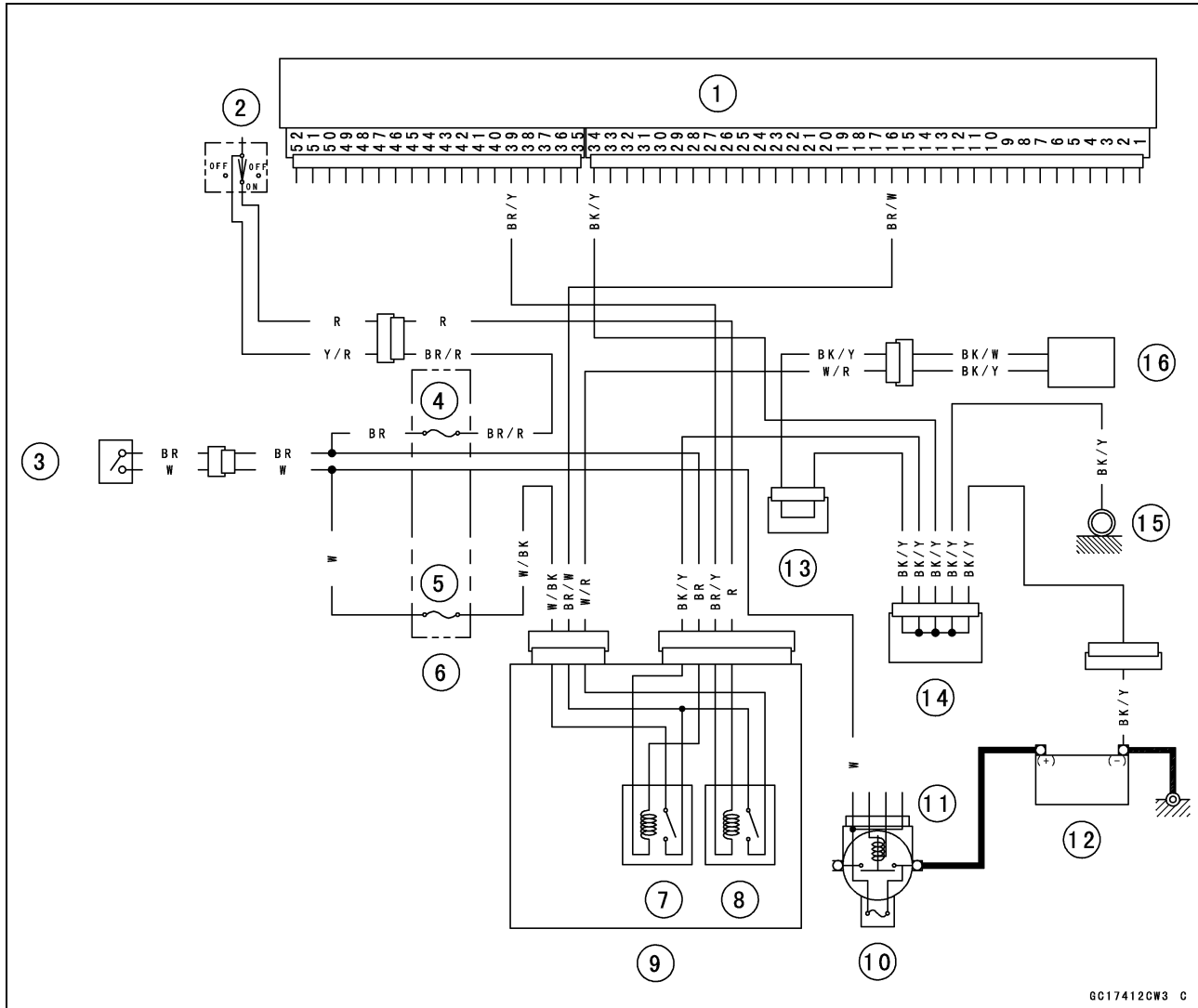

1. ECU
2. Engine Stop Switch
3. Ignition Switch
4. Ignition Fuse 10 A
5. ECU Fuse 15 A
6. Fuse Box
7. ECU Main Relay
8. Fuel Pump Relay
9. Relay Box
10. Main Fuse 30 A
11. Starter Relay
12. Battery
13. Joint Connector A
14. Joint Connector C
15. Frame Ground
16. Fuel Pump

Fuel Pump

Fuel Pump Circuit
(Without Oxygen Sensor Equipped Models) (VN900C9 ~)

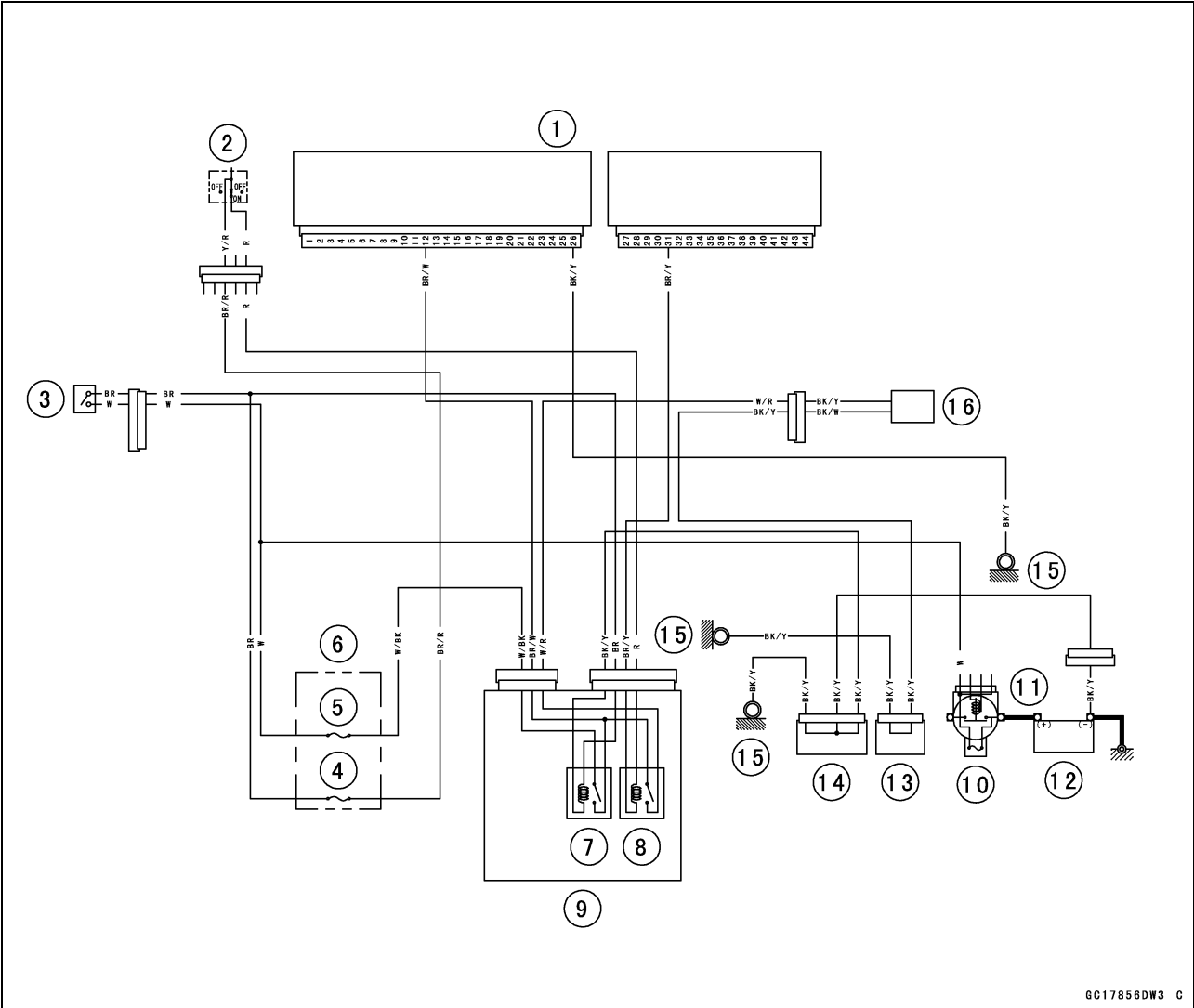

GC17856DW3 C

- 1. ECU
- 2. Engine Stop Switch
- 3. Ignition Switch
- 4. Ignition Fuse 10 A
- 5. ECU Fuse 15 A
- 6. Fuse Box
- 7. ECU Main Relay
- 8. Fuel Pump Relay
- 9. Relay Box
- 10. Main Fuse 30 A
- 11. Starter Relay
- 12. Battery
- 13. Joint Connector A
- 14. Joint Connector C
- 15. Frame Ground
- 16. Fuel Pump

3-114 FUEL SYSTEM (DFI)

Fuel Pump

Fuel Pump Circuit (Oxygen Sensor Equipped Models) (VN900C9 ~)

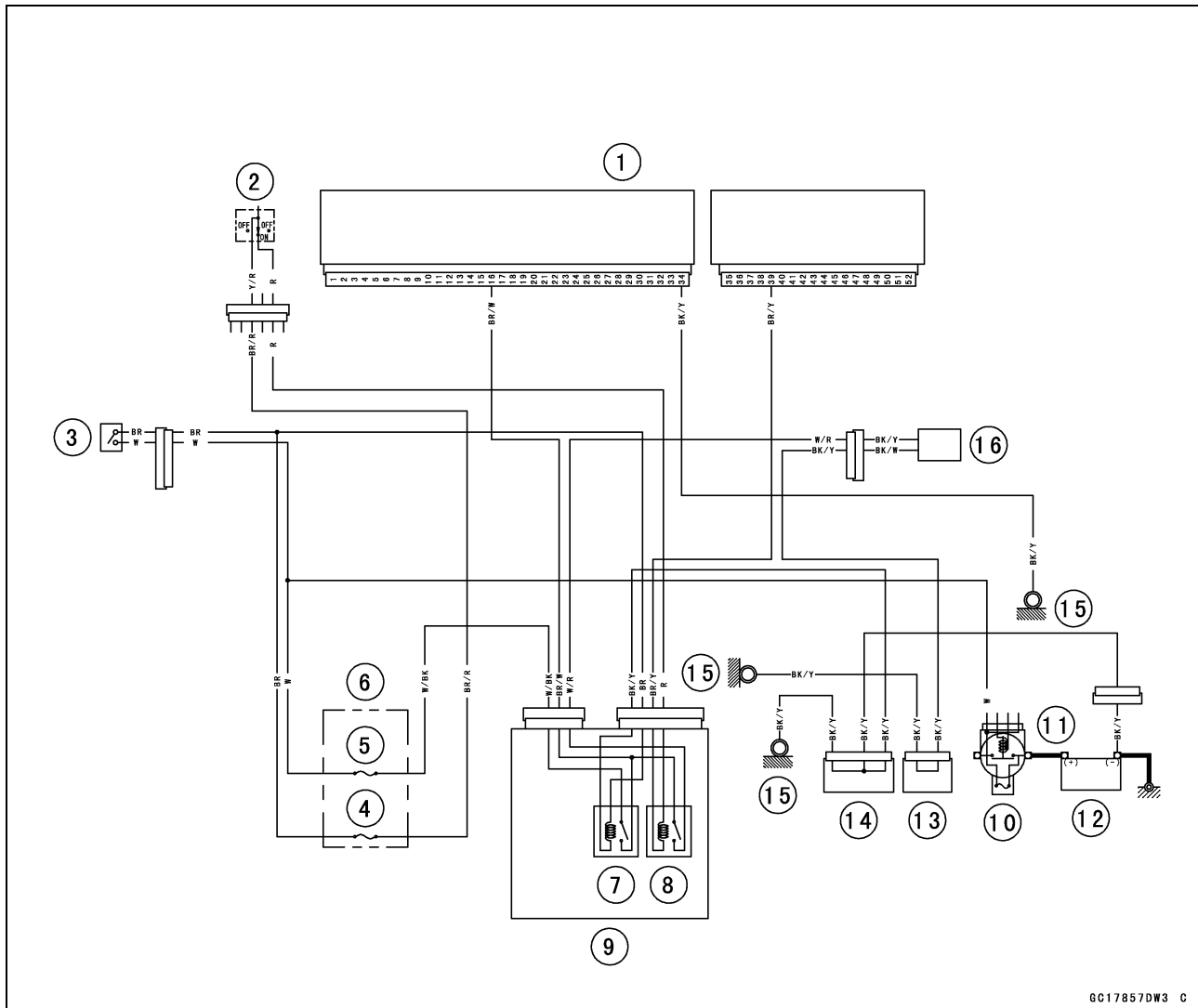

GC17857DW3 C

1. ECU
2. Engine Stop Switch
3. Ignition Switch
4. Ignition Fuse 10 A
5. ECU Fuse 15 A
6. Fuse Box
7. ECU Main Relay
8. Fuel Pump Relay
9. Relay Box
10. Main Fuse 30 A
11. Starter Relay
12. Battery
13. Joint Connector A
14. Joint Connector C
15. Frame Ground
16. Fuel Pump

Fuel Injectors

NOTICE

Never drop the injector, especially on a hard surface. Such a shock to the injector can damage it.

Fuel Injector Removal

⚠ WARNING

Gasoline is extremely flammable and can be explosive under certain conditions, creating the potential for serious burns. Make sure the area is well-ventilated and free from any source of flame or sparks; this includes any appliance with a pilot light. Do not smoke. Turn the ignition switch OFF. Disconnect the battery (–) terminal. To avoid fuel spills, draw it from the tank when the engine is cold. Be prepared for fuel spillage; any spilled fuel must be completely wiped up immediately.

- Check to see that the battery (–) cable terminal is disconnected.
- Remove the fuel tank (see Fuel Tank Removal).
- Disconnect the fuel hose joint connector (see Fuel Hose Replacement in the Periodic Maintenance chapter).
- Disconnect the injector connectors [A].

- Remove:
 Bolt [A]
 Bracket [B]

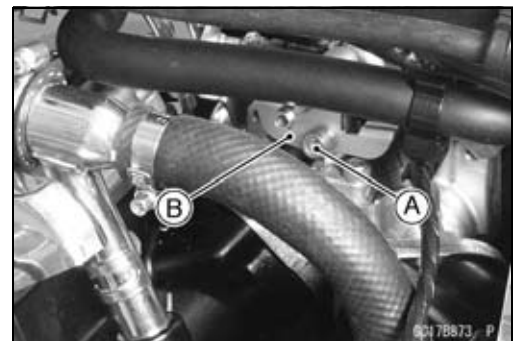
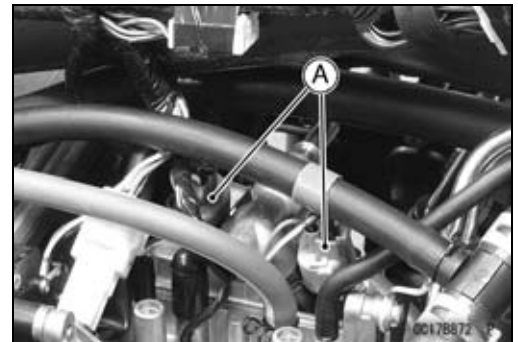

3-116 FUEL SYSTEM (DFI)

Fuel Injectors

- Unscrew the delivery joint bolts [A], and lift up the delivery joint [B] with the injectors [C].
- Remove the injectors from the delivery joint.

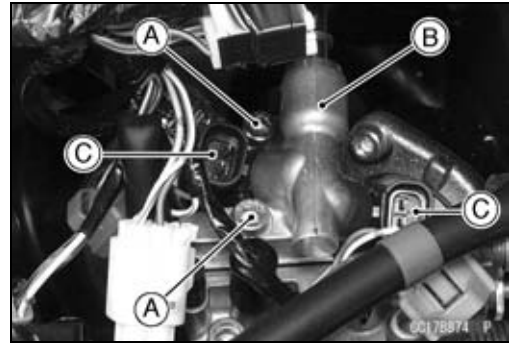

Fuel Injector Installation

- The front and rear injectors are the same.
- Replace the seal [A] and O-ring [B] with new ones, and install them onto the injector [C].
- Apply engine oil to the O-ring, and install them onto the injector.

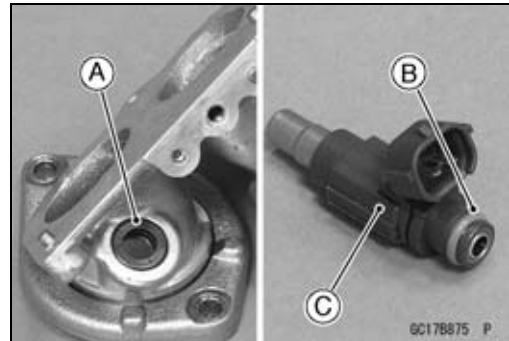

NOTICE

To avoid air and fuel leak, be careful not to get dirt or dust on the O-ring. Be careful not to damage the O-ring.

- Apply grease to the O-ring [A], and install each injector [B] into the delivery joint [C].

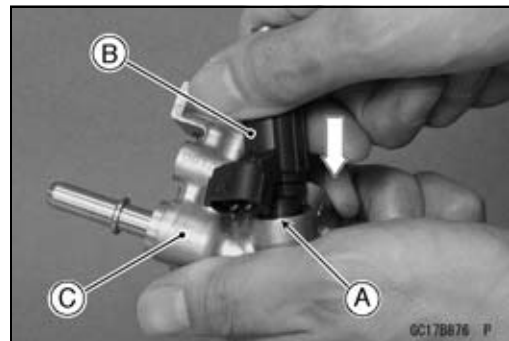

- Check that there is no dirt or dust on the injector seating surface [A] of the inlet manifold [B].
- Check that the two dowel pins [C] are in place in the inlet manifold.
- Fit the end of the injector into the delivery joint, and install them into the inlet manifold.
- Apply a non-permanent locking agent to the delivery joint bolts, and tighten them.

Torque - Delivery Joint Bolts: 9.8 N·m (1.0 kgf·m, 87 in·lb)

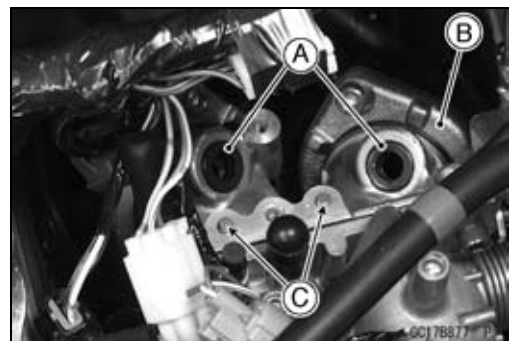

- Install the delivery joint bracket [A] so that the bracket recesses fit the connections.
- Tighten:

Torque - Delivery Joint Bracket Bolt [B]: 9.8 N·m (1.0 kgf·m, 87 in·lb)

- Install the fuel tank (see Fuel Tank Installation).
- Connect the battery (-) cable.

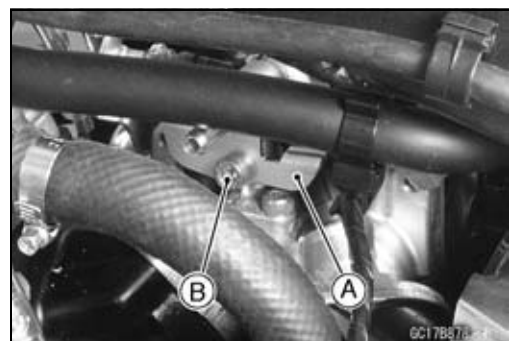

Fuel Injectors

Fuel Injector Fuel Line Inspection

- Remove:
 - Fuel Tank (see Fuel Tank Removal)
 - Fuel Hose (see Fuel Hose Replacement in the Periodic Maintenance chapter)
- Check the injector fuel line for leakage as follows.
 - Connect a commercially available vacuum/pressure pump [A] to the nipple of the delivery pipe [B] with a high-pressure fuel hose [C] (both ends connected with clamps [D]) as shown in the figure.

Torque - Fuel Hose Clamp Screws: 1.5 N·m (0.15 kgf·m, 13 in·lb)

- Apply a soap and water solution to the areas [E] as shown in the figure.
- Watching the pressure gauge, squeeze the pump lever [F], and build up the pressure until the pressure reaches the maximum pressure.

Injector Fuel Line Maximum Pressure
Standard: 300 kPa (3.1 kgf/cm², 44 psi)

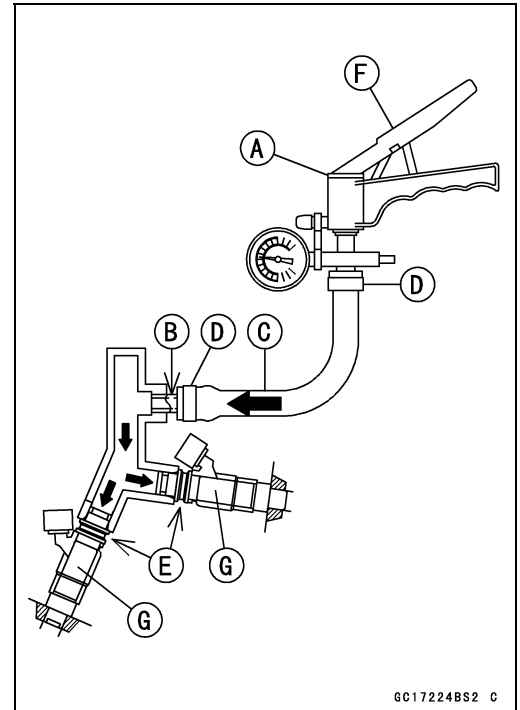

GG17224BS2 C

NOTICE

During pressure testing, do not exceed the maximum pressure for which the system is designed.

- Watch the gauge for at least 6 seconds.
 - ★ If the pressure holds steady, the system is good.
 - ★ If the pressure drops at once, or if bubbles are found in the area, the line is leaking. Perform the following as necessary.
- Retighten the fuel hose clamp screws.
 - Torque - Fuel Hose Clamp Screws: 1.5 N·m (0.15 kgf·m, 13 in·lb)**
- Replace the O-ring of injectors [G].
- Repeat the leak test, and check the fuel line for no leakage.
- Run the hose correctly (see Cable, Wire, and Hose Routing section in the Appendix chapter).
- Install:
 - Fuel Hose (see Fuel Hose Replacement in the Periodic Maintenance chapter)
 - Fuel Tank (see Fuel Tank Installation)

3-118 FUEL SYSTEM (DFI)

Fuel Injectors

Fuel Injector Audible Inspection

- Start the engine.
- Insert a screwdriver from the engine right side between the fuel tank bottom end and the engine top end.
- Apply the tip of a screwdriver [A] to the injector [B]. Put the grip end onto your ear, and listen whether the injector is clicking or not.
- A sound scope [C] can also be used.
- Do the same for the other injector.
- ★ If all the injectors click at a regular intervals, the injectors are good. The trouble may be related to the fuel line, requiring fuel pressure inspection (see Injector Fuel Line Inspection).
- The click interval becomes shorter as the engine speed rises.
- ★ If either injector doesn't click, the DFI circuit or the injector is suspect. Perform the "Fuel Injector Power Source Voltage Inspection", first.

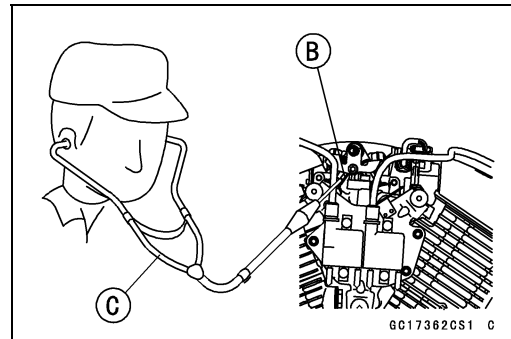
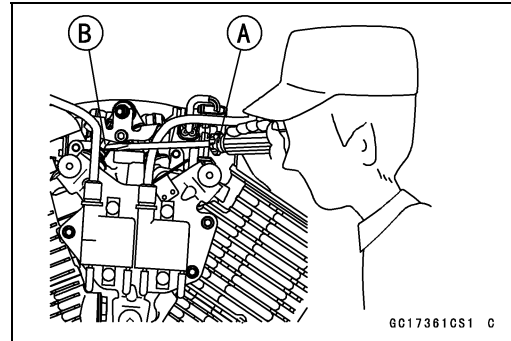

Fuel Injector Power Source Voltage Inspection

- Remove the ECU (see ECU Removal).
 - Do not disconnect the ECU connector.
 - Connect a digital meter to the ECU connector, using the needle adapter set.
- Special Tool - Needle Adapter Set: 57001-1457**
- Measure the power source voltage with the engine stopped, and with the connector joined.
 - Turn the ignition switch ON.

Injector Power Source Voltage at ECU

(Without Oxygen Sensor Equipped Models [A])

Connections: Meter (+) → BR/W (terminal 12)

Meter (-) → Battery (-) Terminal

(Oxygen Sensor Equipped Models [B])

Connections: Meter (+) → BR/W (terminal 16)

Meter (-) → Battery (-) Terminal

Service Limit: Battery Voltage (12.8 V or more)

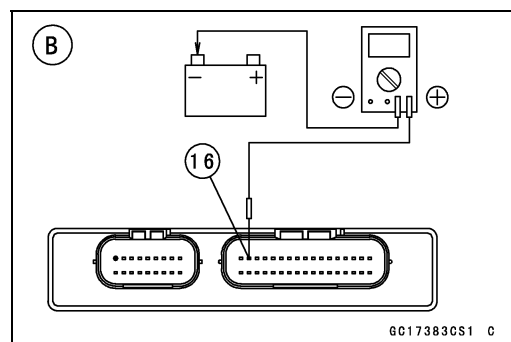
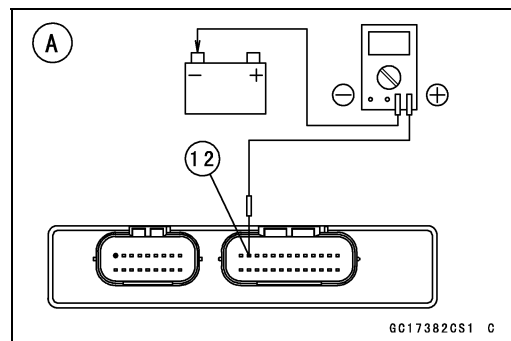

- ★ If the meter doesn't read as specified, check the following.
 - Main Fuse 30 A (see Fuse Inspection in the Electrical System chapter)
 - Fuel Pump Relay (see Relay Circuit Inspection in the Electrical System chapter)
 - Power Source Wiring (see wiring diagram below)
- To check the W/R leads between the injector connector and the fuel pump relay, remove the fuel tank (see Fuel Tank Removal) and the right side cover (see Right Side Cover Removal in the Frame chapter).
- ★ If the power source voltage is normal, check the output voltage of the injectors.

Fuel Injectors

Fuel Injector Output Voltage Inspection

- Turn the ignition switch OFF.
- Remove the ECU (see ECU Removal). Do not disconnect the ECU connector.
- Connect a digital voltmeter to the connector, using the needle adapter set.

Special Tool - Needle Adapter Set: 57001-1457

Injector Output Voltage at ECU

(Without Oxygen Sensor Equipped Models [A])

Connections for Injector #1

Meter (+) → BL/R lead (terminal 34)

Meter (-) → Battery (-) Terminal

Connections for Injector #2

Meter (+) → BL/G lead (terminal 33)

Meter (-) → Battery (-) Terminal

(Oxygen Sensor Equipped Models [B])

Connections for Injector #1

Meter (+) → BL/R lead (terminal 42)

Meter (-) → Battery (-) Terminal

Connections for Injector #2

Meter (+) → BL/G lead (terminal 41)

Meter (-) → Battery (-) Terminal

- Turn the ignition switch ON.
- Start the engine.

Standard: Battery Voltage (12.8 V or more)

- Turn the ignition switch OFF.

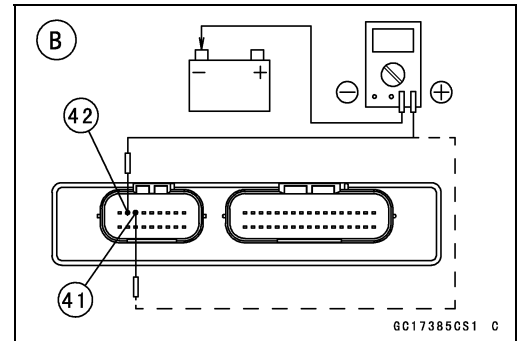
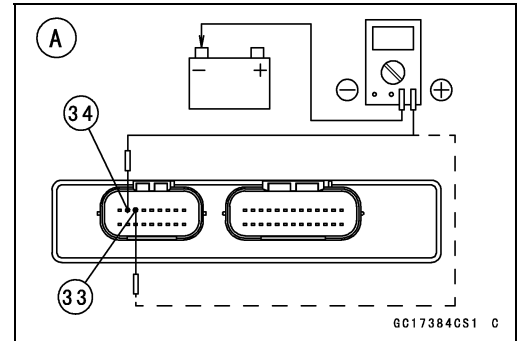

3-120 FUEL SYSTEM (DFI)

Fuel Injectors

- ★ If the output voltage is normal, perform the "Fuel Injector Signal Test".
- ★ If the output voltage is out of the standard, turn the ignition switch OFF, remove the fuel tank, and check the injector wiring for continuity.

Injector Wiring Inspection

(Without Oxygen Sensor Equipped Models)

| ECU Connector | | Injector Connectors |
|---------------|---|-----------------------------|
| Terminal 12 | → | Injector #1 Terminal (W/R) |
| Terminal 12 | → | Injector #2 Terminal (W/R) |
| Terminal 34 | → | Injector #1 Terminal (BL/R) |
| Terminal 33 | → | Injector #2 Terminal (BL/G) |

(Oxygen Sensor Equipped Models)

| ECU Connector | | Injector Connectors |
|---------------|---|-----------------------------|
| Terminal 16 | → | Injector #1 Terminal (W/R) |
| Terminal 16 | → | Injector #2 Terminal (W/R) |
| Terminal 42 | → | Injector #1 Terminal (BL/R) |
| Terminal 41 | → | Injector #2 Terminal (BL/G) |

- ★ If the wiring is good, inspect the resistance of the injectors (see Fuel Injector Resistance Inspection).
- Remove the needle adapter set.
- Apply silicone sealant to the seals of the ECU connector for waterproofing.

Sealant - Liquid Gasket, TB1211: 56019-120

Fuel Injector Signal Test

- Prepare two test light sets with terminals as shown in the figure.
Rating of Bulb [A]: 12 V × 3 ~ 3.4 W
Terminal Width [B]: 1.8 mm (0.07 in.)
Terminal Thickness [C]: 0.8 mm (0.03 in.)

NOTICE

Do not use larger terminals than specified above. A larger terminal could damage the fuel injector main harness connector, leading to harness repair or replacement.
Be sure to connect bulbs in series. The bulb works as a current limiter to protect the solenoid in the fuel injector from excessive current.

- Remove connectors for fuel injector [A].
- Connect each test light set [B] to the fuel injector main harness connector [C].
- Turn the ignition switch ON.
- While cranking the engine with the starter motor, watch the test lights.
- ★ If the test lights flicker at regular intervals, the fuel injector circuit in the ECU, and the wiring are good. Perform the "Fuel Injector Resistance Inspection".

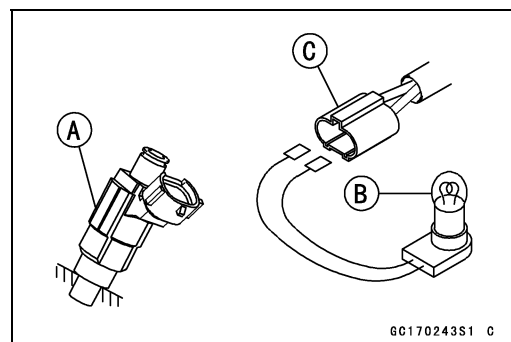
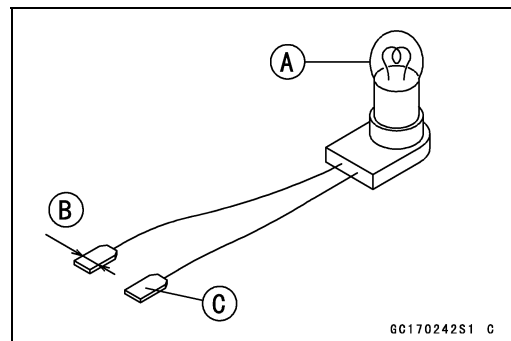

Fuel Injectors

○ Fuel injector signals can be also confirmed by connecting the tester instead of the test light set to the fuel injector main harness connector. Crank the engine with the starter motor, and check to see if the needle oscillates at regular intervals.

★ If the test light doesn't flicker (or the tester needle doesn't oscillates), check the wiring and connectors again. If the wiring is good, the ECU is suspect. Replace the ECU.

Fuel Injector Resistance Inspection

- Remove the fuel tank (see Fuel Tank Removal).
- Disconnect the connector from the injector (see Fuel Injector Removal).
- Measure the fuel injector resistance with a digital voltmeter [A].

Fuel Injector Resistance

Connections to Injector

| Meter (+) | | Meter (-) |
|-----------|---|---------------|
| #1: W/R | ↔ | BL/R Terminal |
| #2: W/R | ↔ | BL/G Terminal |

Standard: 11.7 ~ 12.3 Ω at 20°C (68°F)

★ If the reading is out of the range, perform the "Fuel Injector Unit Test".

★ If the reading is normal, perform the "Fuel Injector Unit Test" for confirmation.

Fuel Injector Unit Test

- Use two wires [A] and the same test light set [B] as in "Fuel Injector Signal Test".
- Rating of Bulb [C]: 12 V × (3 ~ 3.4) W
- 12 V Battery [D]

NOTICE

Be sure to connect the bulb in series. The bulb works as a current limiter to protect the solenoid in the fuel injector from excessive current.

- Connect the test light set to the fuel injector [E] as shown in the figure.
- Open and connect [F] the end of the wire to the battery (-) terminal repeatedly. The fuel injector should click.
- ★ If the fuel injector does not click, replace the fuel injector.
- ★ If the fuel injector clicks, check the wiring again. If the wiring is good, replace the fuel injector (may be clogged) or ECU.

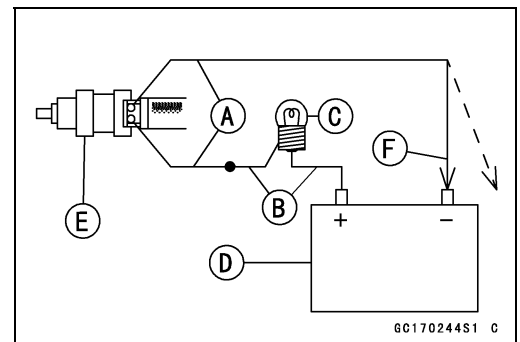
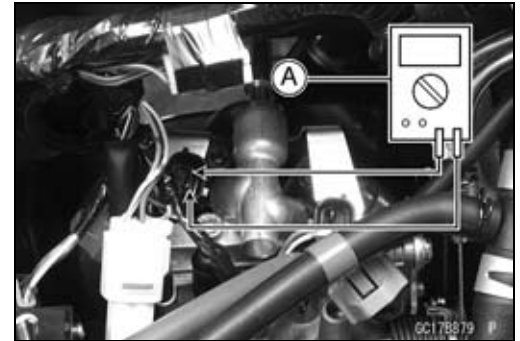

3-122 FUEL SYSTEM (DFI)

Fuel Injectors

Fuel Injector Circuit (Without Oxygen Sensor Equipped Models) (VN900C7 ~ C8)

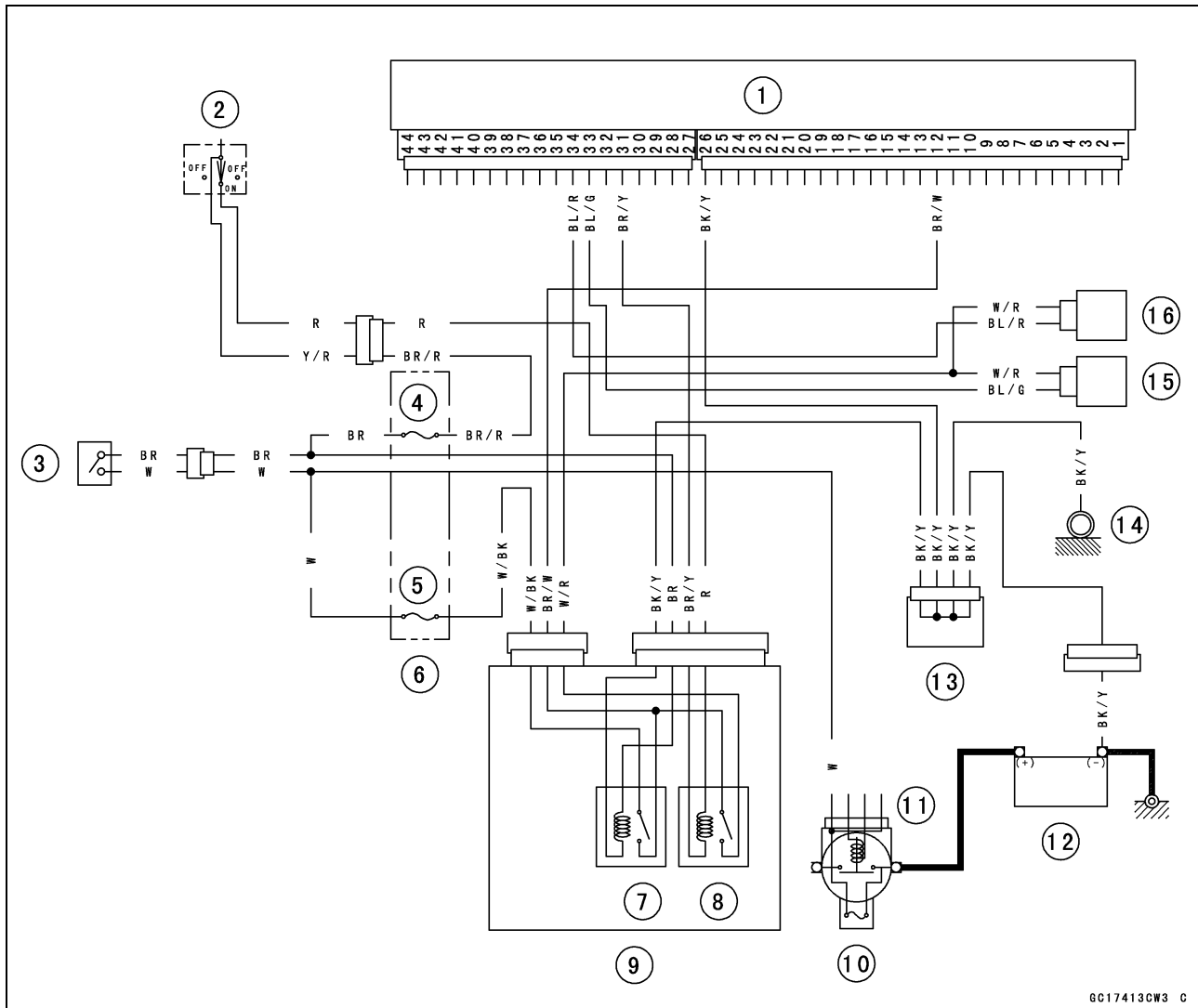

1. ECU
2. Engine Stop Switch
3. Ignition Switch
4. Ignition Fuse 10 A
5. ECU Fuse 15 A
6. Fuse Box
7. ECU Main Relay
8. Fuel Pump Relay
9. Relay Box
10. Main Fuse 30 A
11. Starter Relay
12. Battery
13. Joint Connector C
14. Frame Ground
15. Injector #2
16. Injector #1

Fuel Injectors

Fuel Injector Circuit
(Oxygen Sensor Equipped Models) (VN900C7 ~ C8)

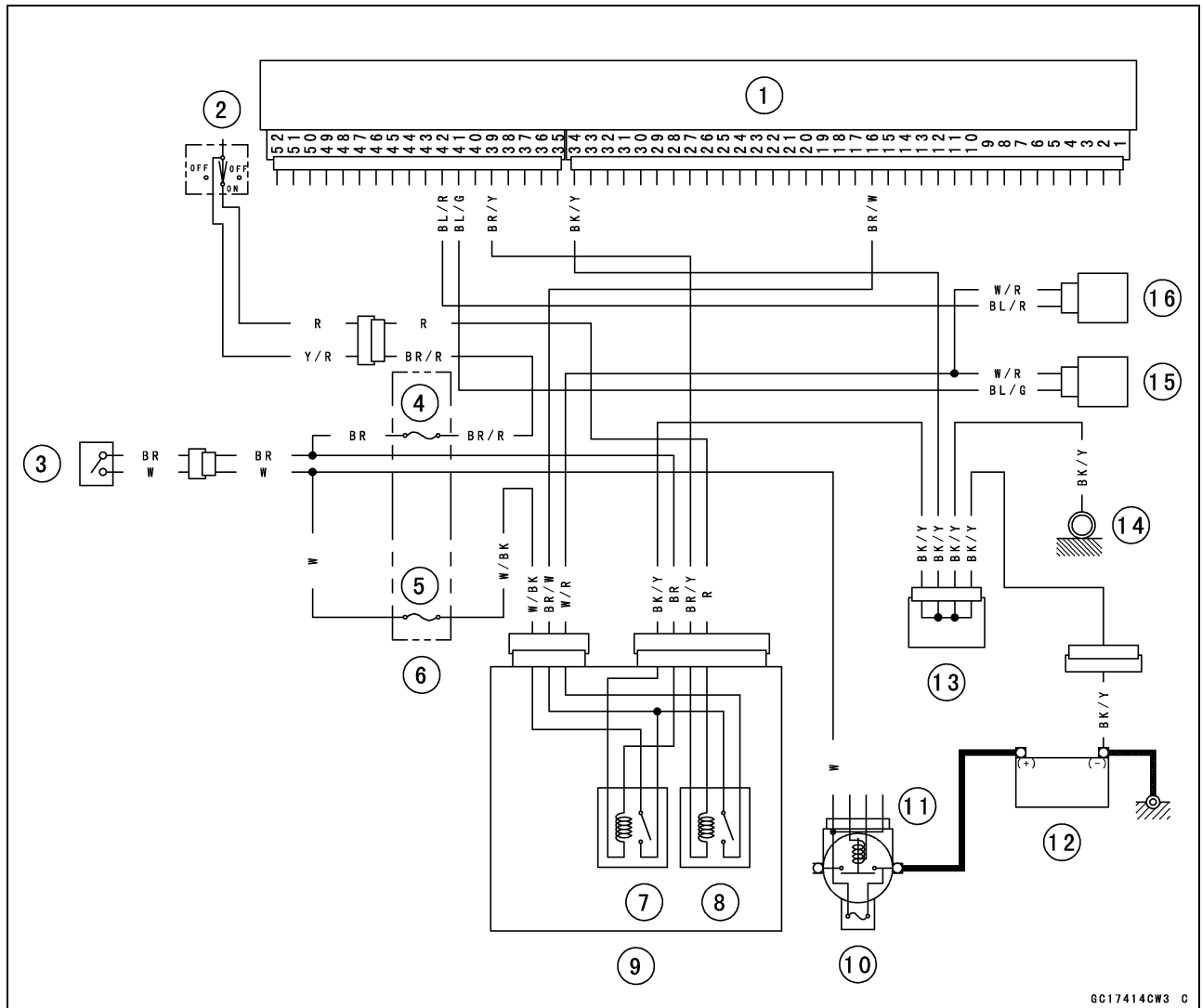

GC17414CW3 C

1. ECU
2. Engine Stop Switch
3. Ignition Switch
4. Ignition Fuse 10 A
5. ECU Fuse 15 A
6. Fuse Box
7. ECU Main Relay
8. Fuel Pump Relay
9. Relay Box
10. Main Fuse 30 A
11. Starter Relay
12. Battery
13. Joint Connector C
14. Frame Ground
15. Injector #2
16. Injector #1

3-124 FUEL SYSTEM (DFI)

Fuel Injectors

Fuel Injector Circuit (Without Oxygen Sensor Equipped Models) (VN900C9 ~)

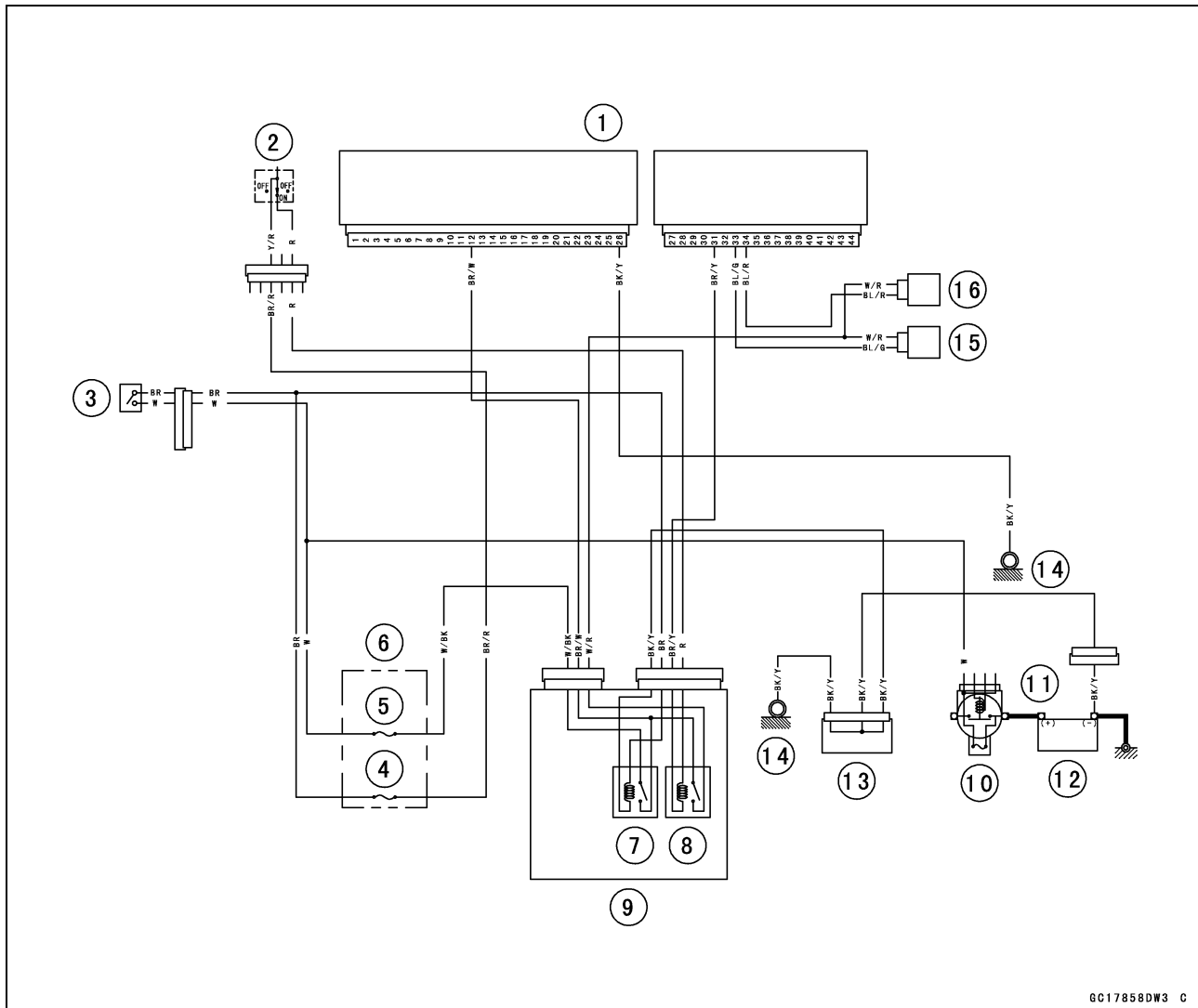

GC17858DW3 C

1. ECU
2. Engine Stop Switch
3. Ignition Switch
4. Ignition Fuse 10 A
5. ECU Fuse 15 A
6. Fuse Box
7. ECU Main Relay
8. Fuel Pump Relay
9. Relay Box
10. Main Fuse 30 A
11. Starter Relay
12. Battery
13. Joint Connector C
14. Frame Ground
15. Injector #2
16. Injector #1

Fuel Injectors

Fuel Injector Circuit
(Oxygen Sensor Equipped Models) (VN900C9 ~)

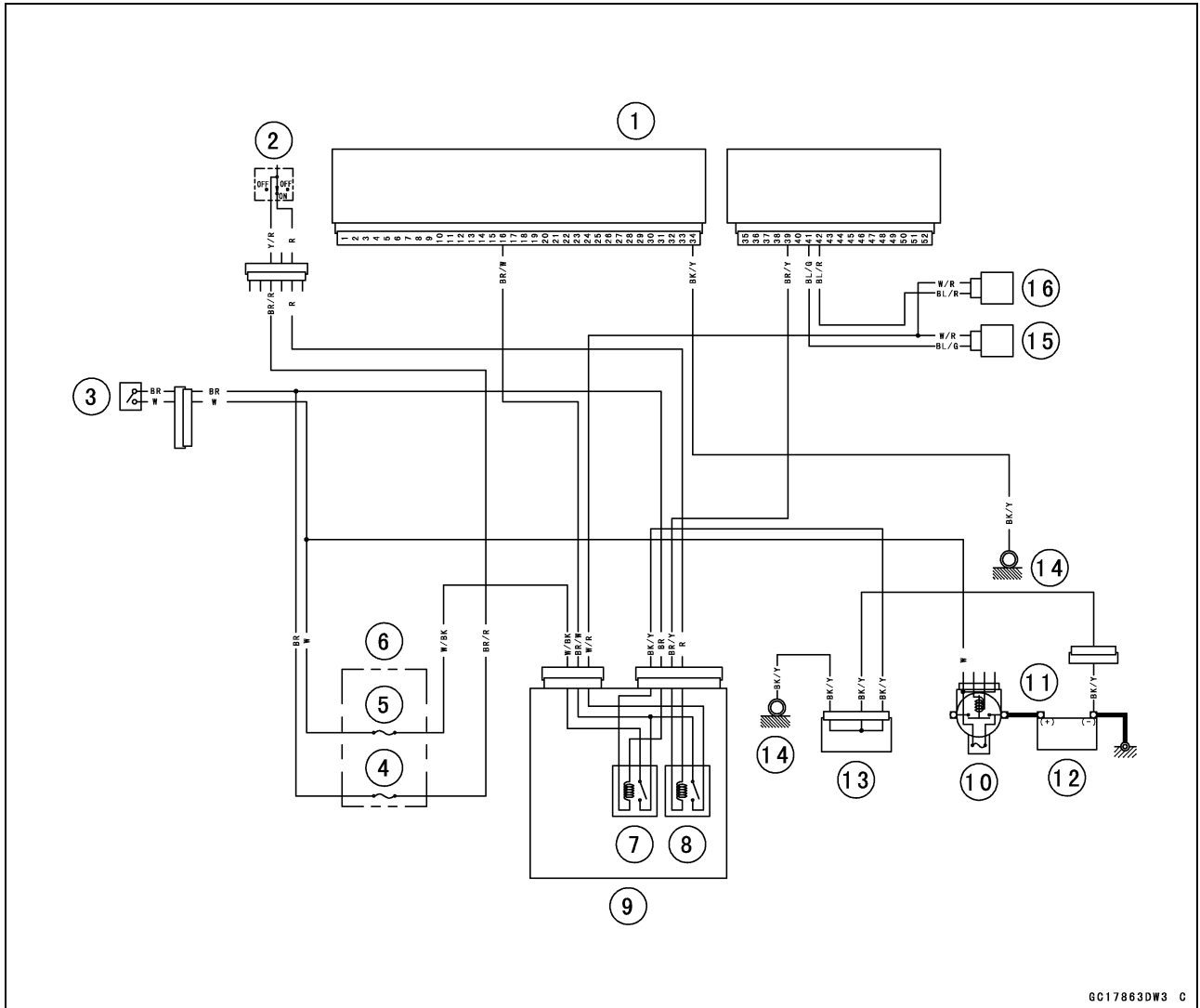

GC17863DW3 C

1. ECU
2. Engine Stop Switch
3. Ignition Switch
4. Ignition Fuse 10 A
5. ECU Fuse 15 A
6. Fuse Box
7. ECU Main Relay
8. Fuel Pump Relay
9. Relay Box
10. Main Fuse 30 A
11. Starter Relay
12. Battery
13. Joint Connector C
14. Frame Ground
15. Injector #2
16. Injector #1

3-126 FUEL SYSTEM (DFI)

Throttle Grip and Cables

Throttle Grip Free Play Inspection

- Refer to the Throttle Control System Inspection in the Periodic Maintenance chapter.

Throttle Grip Free Play Adjustment

- Refer to the Throttle Control System Inspection in the Periodic Maintenance chapter.

Cable Removal/Installation

- Refer to the Throttle Body Assy and Inlet Manifold Removal and Installation.

Cable Lubrication and Inspection

- Whenever the throttle cables are removed or in accordance with the Periodic Maintenance Chart, lubricate these cables. Refer to the Chassis Parts Lubrication in the Periodic Maintenance chapter.
- Use a commercially available pressure cable lubricator to lubricate these cables.
- With the cable disconnected at both ends, the cable should move freely in the cable housing.

Throttle Body Assy

Idle Speed Inspection

- Refer to the Idle Speed Inspection in the Periodic Maintenance chapter.

Idle Speed Adjustment

- Refer to the Idle Speed Adjustment in the Periodic Maintenance chapter.

Throttle Bore Cleaning

- Check the throttle bore for cleanliness as follows.
 - Remove the air cleaner housing (see Air Cleaner Housing Removal).
 - Check the throttle bores [A] at the throttle valves [B] and around them for carbon deposits by opening the valves.
 - ★ If any carbon accumulates, wipe the carbon off the throttle bores around the throttle valves, using a lint-free cloth [C] penetrated with a high flash-point solvent.

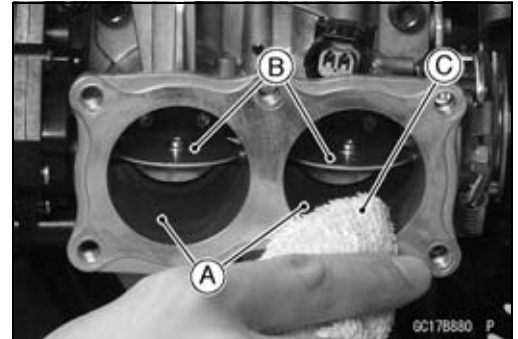

High Altitude Performance Adjustment

- Any modification is not necessary in this model since the atmospheric pressure sensor senses pressure change due to high altitude and the ECU compensates the change.

Throttle Body Assy and Inlet Manifold Removal

⚠ WARNING

Gasoline is extremely flammable and can be explosive under certain conditions, creating the potential for serious burns. Make sure the area is well-ventilated and free from any source of flame or sparks; this includes any appliance with a pilot light. Do not smoke. Turn the ignition switch OFF. Disconnect the battery (-) terminal. To avoid fuel spills, draw it from the tank when the engine is cold. Be prepared for fuel spillage; any spilled fuel must be completely wiped up immediately.

- Remove:
 - Fuel Tank (see Fuel Tank Removal)
 - Air Cleaner Housing (see Air Cleaner Housing Removal)
- Disconnect:
 - Vacuum Hose [A] from Separator (CAL, TH and SEA-B1 Models)
 - Vacuum Hose [B] from Inlet Air Pressure Sensor
 - Connectors [C]

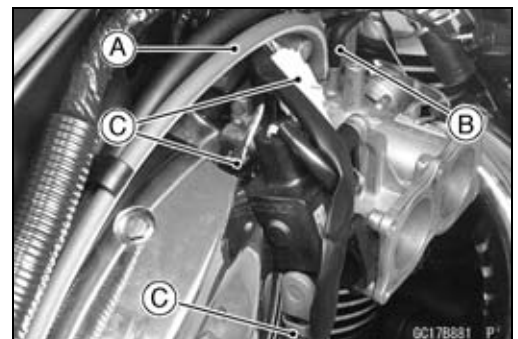

3-128 FUEL SYSTEM (DFI)

Throttle Body Assy

- Remove the screws and take off the right switch housing.
- Remove the accelerator cable end [A] and decelerator cable end [B] at the throttle grip.

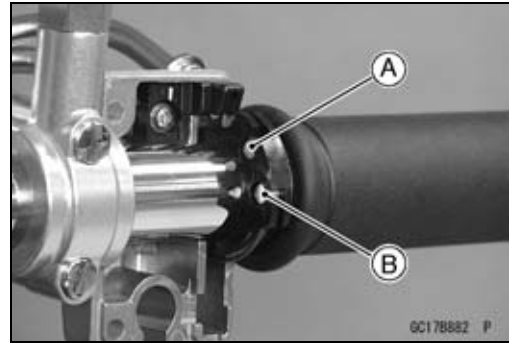

- Disconnect the fuel injector connectors [A].
- Unscrew the bolts [B] and remove the throttle body assy [C] with the throttle cables from the inlet manifold.

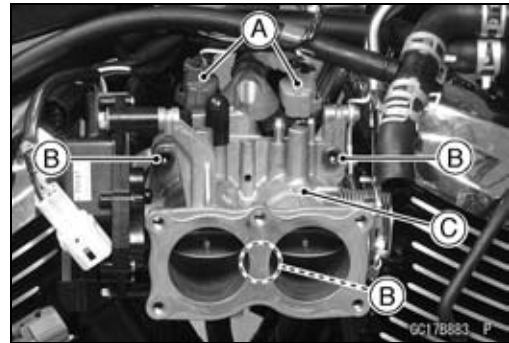

- Remove:
 - Clip [A]
 - Accelerator Cable End [B]
 - Decelerator Cable End [C]

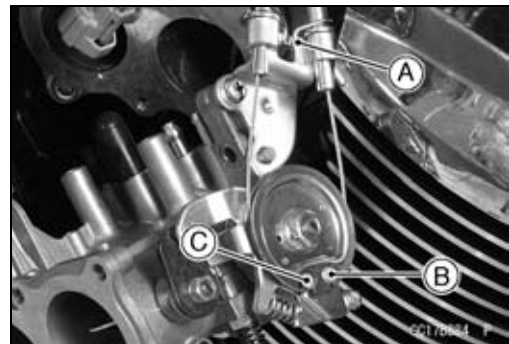

- Remove the fuel injectors (see Fuel Injector Removal).
- Unscrew the mounting bolts [A] and remove the inlet manifold [B].

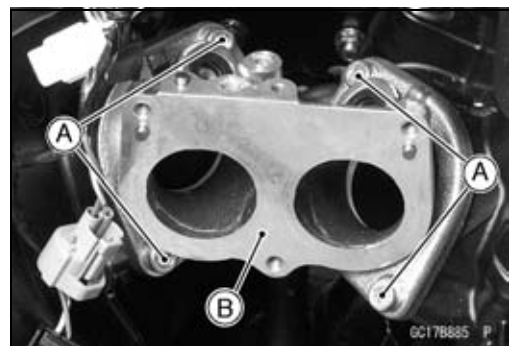

Throttle Body Assy

- Be careful not to damage (dent, nick, flaw, and crack) the flange mating surface and the plastic parts.
- Do not drop the throttle body assy, especially on a hard surface.

⚠ WARNING

Impacts can cause the throttle to stick, resulting in an accident causing severe injury or death. Do not drop the throttle assembly.

- Stuff a piece of lint-free, clean cloth into the throttle body assy, and the inlet ports of the cylinder heads to keep dirt out of the engine.

⚠ WARNING

**If dirt or dust is allowed to pass through into the carburetor, the throttle may become stuck, possibly causing accident.
Replace the air cleaner element according to the maintenance chart.**

NOTICE

If dirt gets through into the engine, excessive engine wear and possibly engine damage will occur.

- Do not remove or adjust the throttle sensors [A] and sub-throttle valve actuator [B]. These parts are set at the factory and cannot be readjusted.

NOTICE

Adjustment of some parts could result in poor performance, requiring replacement of the throttle body.

Throttle Body Assy and Inlet Manifold Installation

- Turn the throttle pulley [A] to check that the throttle valves move smoothly and return by spring force.
- ★ If the throttle valves do not move smoothly, replace the throttle body assy.

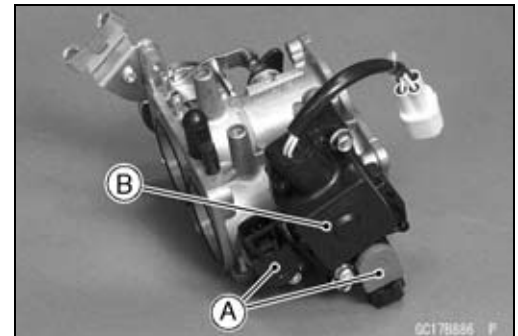

3-130 FUEL SYSTEM (DFI)

Throttle Body Assy

- Open the butterfly valves [A], and wipe any carbon off the throttle bores [B] around the valves, using a piece of lint-free cloth penetrated with a high flash-point solvent.
- Clean the bores [C] of the inlet manifold [D] as well.
- Blow away dirt or dust from the throttle body and the inlet manifold by applying compressed air.

NOTICE

Do not immerse the throttle body (or throttle assy) in a high flash-point solvent for cleaning. This could damage the throttle sensor on the throttle body.

- Before installation, visually inspect the mating surfaces [A] for any damage, like dent, nick, rust, flaw, and crack.
- Nick or rust damage can sometimes be repaired by using emery paper (first No. 200, then 400) to remove sharp edges or raised areas.
- ★ If the damage is not repairable, replace the throttle body and/or the inlet manifold to prevent leakage.
- With a high flash-point solvent, clean off the mating surfaces and wipe dry.
- Be sure to install the dowel pins [B].
- Fit the new gasket [C] into the groove. Be careful not to pinch the gasket between the mating surfaces.
- Replace the flange seals [A] with new ones.
- With a high flash-point solvent, clean off the flange surface of the cylinder head and wipe dry.
- Install the flanges [B] and seal so that the larger diameter end face cylinder head.
- The seal should be centered on the flange.
- Apply a non-permanent locking agent to the inlet manifold bolts, and tighten them.

Torque - Inlet Manifold Bolts: 9.8 N·m (1.0 kgf·m, 87 in·lb)

- Install the lower end of the throttle cables in the throttle pulley.

Accelerator Cable [A]
Decelerator Cable [B]

- Install the throttle body assy.
- Tighten:

Torque - Throttle Body Assy Holder Bolts: 9.8 N·m (1.0 kgf·m, 87 in·lb)

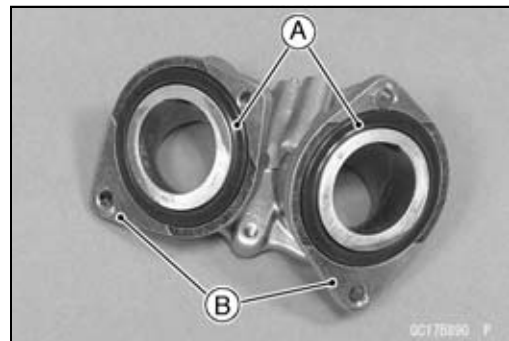
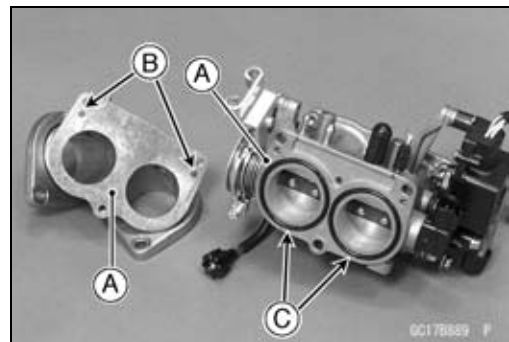
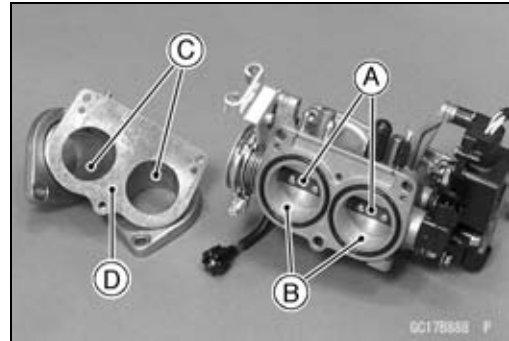

Throttle Body Assy

- Stake the cable clip [A] on the throttle cable holder [B].



- Apply a thin coating of grease to the throttle cable upper ends.
- Install the upper ends of the throttle cables to the throttle grip.
- Fit the projection [A] of the right switch housing into the hole [B] of the handlebar.
- Turn the throttle grip and make sure that the throttle valves move smoothly and return by spring force.
- Check the throttle grip free play (see Throttle Control System Inspection in the Periodic Maintenance chapter).

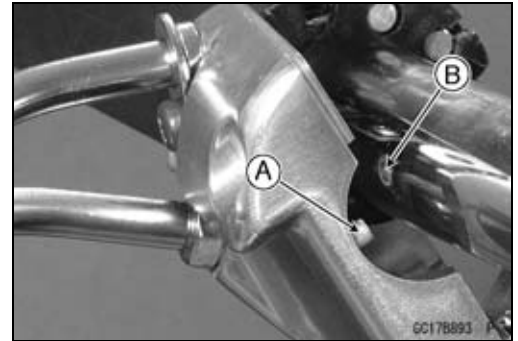

⚠ WARNING

Operation with an incorrectly routed cable could result in an unsafe riding condition. Be sure the cable is routed correctly.

3-132 FUEL SYSTEM (DFI)

Air Cleaner

Air Cleaner Element Removal/Installation

- Refer to the Air Cleaner Element Replacement in the Periodic Maintenance chapter.

Air Cleaner Housing Removal

- Remove the air cleaner housing bolts [A].

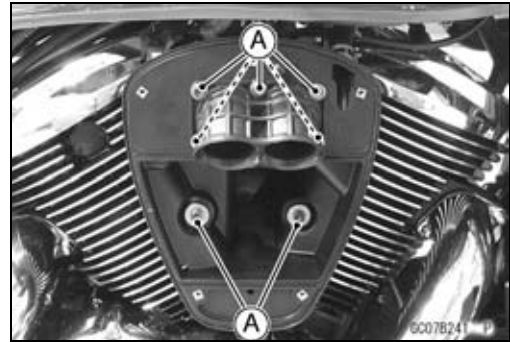

- Clear the idle speed screw [A] from the recess on the air cleaner housing.

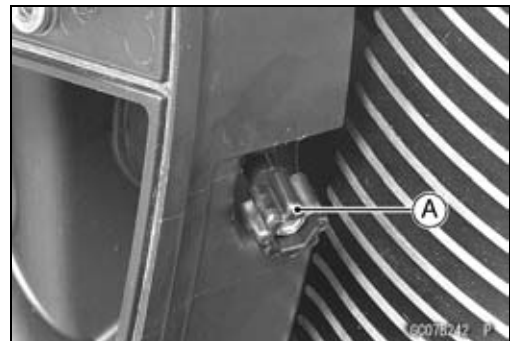

- Pull the air cleaner housing [A] and disconnect the following.
 - Air Switching Valve Hose [B]
 - Inlet Air Temperature Sensor Connector [C]
 - Crankcase Breather Hose [D]
- Remove the air cleaner housing.

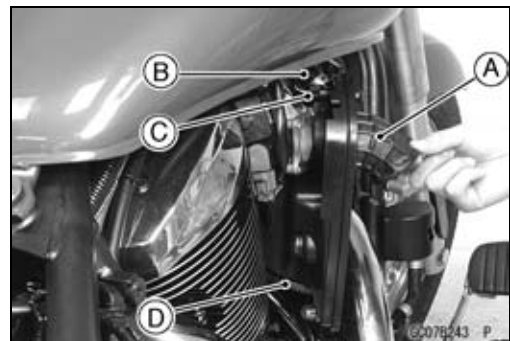

Air Cleaner Housing Installation

- Check that oil is in the breather drain cap [A].
 - ★ If necessary, drain the oil in the cap.

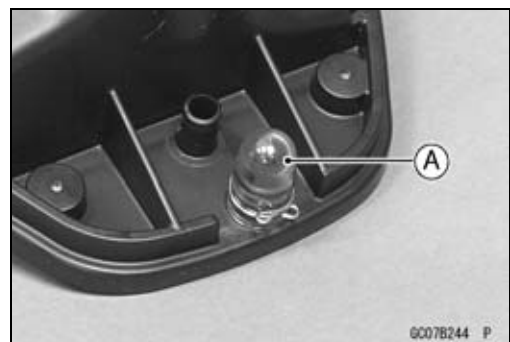

Air Cleaner

- Fit the adjusting screw [A] in the recess on the air cleaner housing.

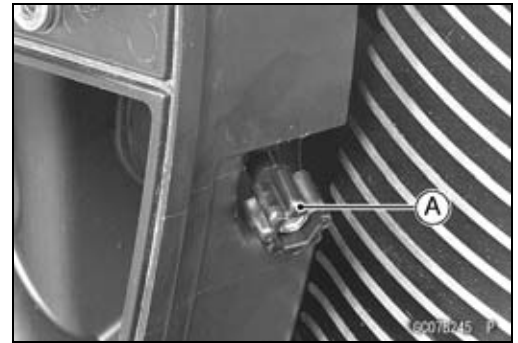

- Be sure the dampers [A] and collars [B] are in position.
- Install the damper into the air cleaner housing [C] as shown in the figure.
 - Smaller Diameter [D]
 - Larger Diameter [E]

Torque - Air Cleaner Housing Bolts: 9.8 N·m (1.0 kgf·m, 87 in·lb)

Air Cleaner Cover Bolts: 4.9 N·m (0.50 kgf·m, 43 in·lb)

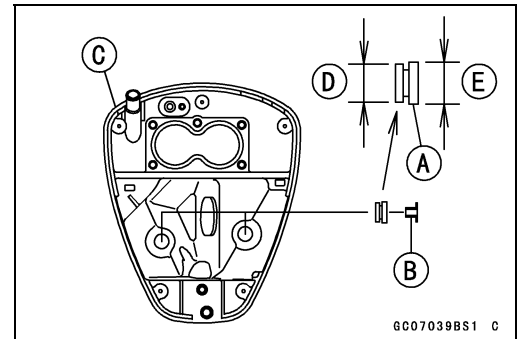

GC07039BS1 C

3-134 FUEL SYSTEM (DFI)

Fuel Tank

Fuel Tank Removal

⚠ WARNING

Gasoline is extremely flammable and can be explosive under certain conditions, creating the potential for serious burns. Make sure the area is well-ventilated and free from any source of flame or sparks; this includes any appliance with a pilot light. Do not smoke. Turn the ignition switch OFF. Disconnect the battery (-) terminal. To avoid fuel spills, draw it from the tank when the engine is cold. Be prepared for fuel spillage; any spilled fuel must be completely wiped up immediately.

- Turn both ignition switch, and engine stop switch OFF.
- Wait until the engine cools down.
- Open the fuel tank cap [A] to lower the pressure in the tank, and draw the fuel out from the fuel tank with a commercially available pump.

⚠ WARNING

Spilled fuel is flammable and can be explosive under certain conditions. The fuel can not be removed completely from the fuel tank. Be careful for remained fuel spillage.

- Disconnect the battery (-) cable terminal.
- Remove:
 - Bolt [A]
 - Meter Cover [B]

- Disconnect:
 - Meter Connector [A]
 - Fuel Level Sensor Connector [B]
 - Breather Hose [C]

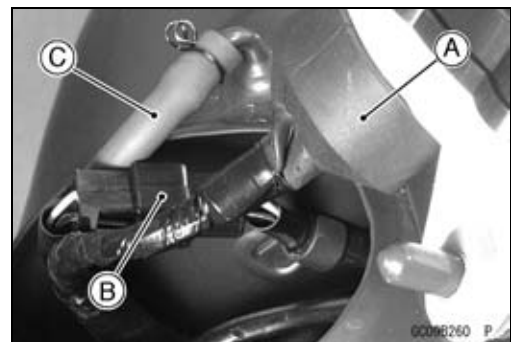

Fuel Tank

- Remove:
Seat (see Seat Removal in the Frame chapter)
Fuel Tank Bolts [A]
- Disconnect:
Fuel Return Hose (Red) [A] (CAL, TH and SEA-B1 Models)
- Unscrew the screw [A], and pull out the ignition coil cover [B].
- Disconnect the fuel pump connector [A].
- Be sure to place a piece of cloth around the fuel hose joint.
- Wipe off the dirt of the surface [A] around the connection using a cloth or a soft brush.

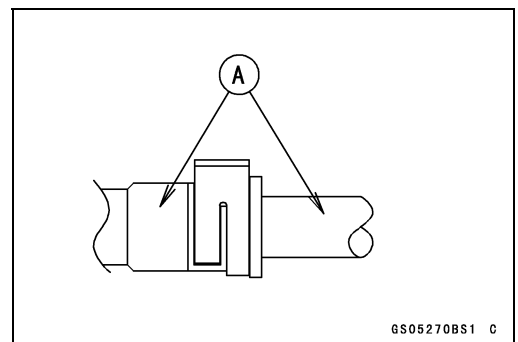
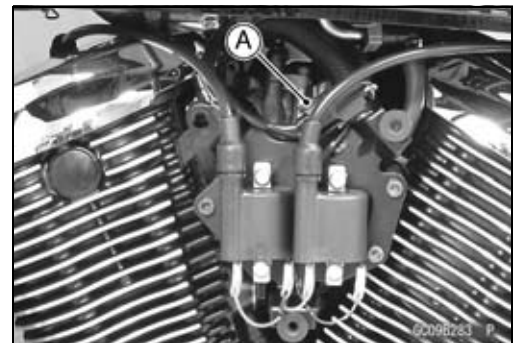

GS05270BS1 C

3-136 FUEL SYSTEM (DFI)

Fuel Tank

When removing with standard tip screwdriver

- Insert the standard tip screwdriver [A] into the slit on the joint lock [B].
- Turn the driver to disconnect the joint lock.

When removing with fingers

- Open and push up [C] the joint lock with your fingers.

NOTICE

Prying or excessively widening the joint lock ends for fuel hose removal will permanently deform the joint lock, resulting in a loose or incomplete lock that may allow fuel to leak and create the potential for a fire explosion. To prevent fire or explosion from a damaged joint lock, do not pry or excessively widen the joint lock ends when removing the fuel hose. The joint lock has a retaining edge that locks around the housing.

- Pull the fuel hose joint out of the outlet pipe.

NOTICE

When removing the fuel hose joint, do not apply strong force to the outlet pipe on the fuel pump. The pipe made from resin could be damaged.

⚠ WARNING

Fuel is flammable and explosive under certain conditions and can cause severe burns. Be prepared for fuel spillage; any spilled fuel must be completely wiped up immediately. When the fuel hose is disconnected, fuel spills out from the hose and the pipe because of residual pressure. Cover the hose connection with a piece of clean cloth to prevent fuel spillage.

- Close the fuel tank cap.
- Remove the fuel tank from the vehicle, and place it on a flat surface.

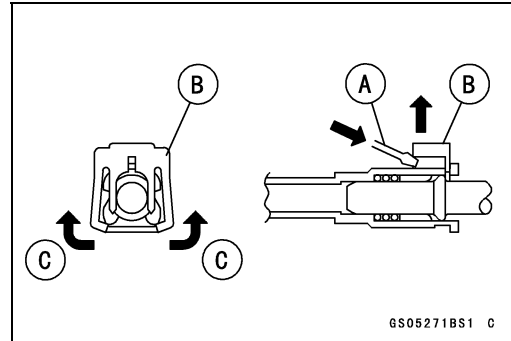

Fuel Tank

- For CAL, TH and SEA-B1 Models, note the following.

NOTICE

For CAL, TH and SEA-B1 models, if gasoline, solvent, water or any other liquid enters the canister, the canister's vapor absorbing capacity is greatly reduced. If the canister does become contaminated, replace it with a new one.

- To prevent the gasoline from flowing into or out of the canister, hold the separator perpendicular to the ground.

⚠ WARNING

Leaking fuel can cause a fire or explosion resulting in severe burns. Make sure the fuel hose joint is installed correctly on the delivery pipe and that it doesn't leak.

- ★ If liquid or gasoline flows into the breather hose, remove the hose and blow it clean with compressed air.
- Be careful of fuel spillage from the fuel tank since fuel still remains in the fuel tank and fuel pump.

⚠ WARNING

Gasoline is extremely flammable and can be explosive under certain conditions, creating the potential for serious burns. Store the fuel tank in an area which is well-ventilated and free from any source of flame or sparks. Do not smoke in this area. Place the fuel tank on a flat surface and plug the fuel pipes to prevent fuel leakage.

- Clean the pipe [A].
- Cover the pipe and the hose joint [B] with the vinyl bags [C] to keep it clean.

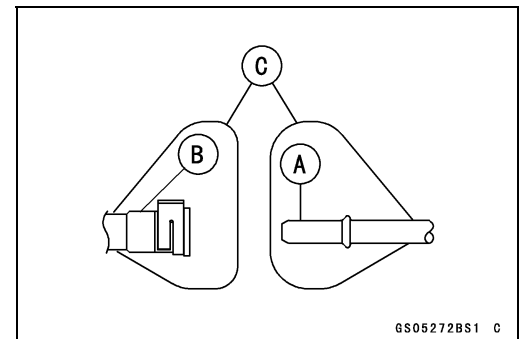

Fuel Tank Installation

- Note the above WARNING (see Fuel Tank Removal).
- Route the hoses correctly (see Cable, Wire, and Hose Routing section in the Appendix chapter).
- For CAL, TH and SEA-B1 Models, note the following.
 - To prevent the gasoline from flowing into or out of the canister, hold the separator perpendicular to the ground.
 - Connect the hoses according to the diagram of the system. Make sure they do not get pinched or kinked.
 - Route the hoses with a minimum of bending so that the air or vapor will not be obstructed.

3-138 FUEL SYSTEM (DFI)

Fuel Tank

- Check that the rubber dampers [A] are in place.
- ★ If the dampers are damaged or deteriorated, replace them.

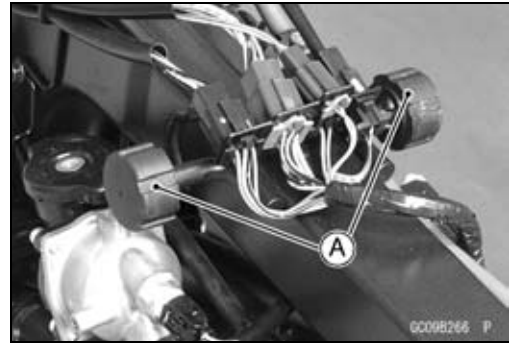

- Remove the vinyl bag on the pipe and fuel hose joint.
- Check the joint lock for deformation and wear.
- ★ If the joint lock is deformed, replace the fuel hose with a new one.
- Check that there are no flaws, burrs, and adhesion of foreign materials on the delivery pipe [A].
- Apply engine oil to the pipe.

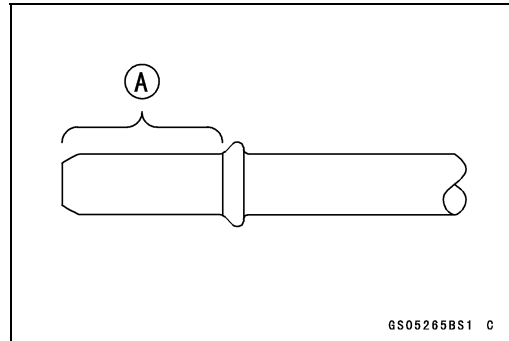

- Pull [A] the joint lock [B] fully as shown in the figure.



- Insert the fuel hose joint [A] straight onto the tank outlet pipe [B].
- Push the joint lock [C].

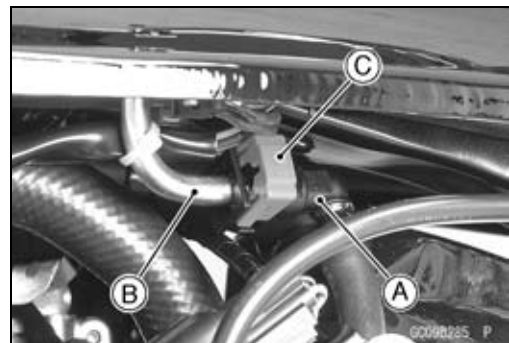

- Push and pull [A] the hose joint [B] back and forth more than two times and make sure it is locked and doesn't come off.

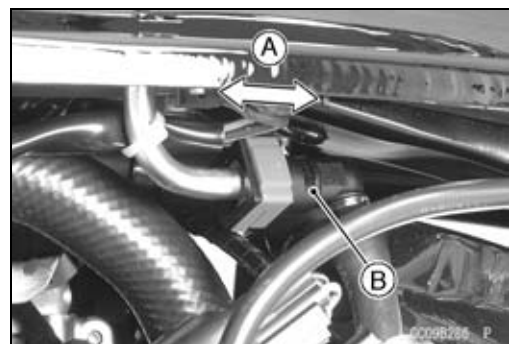

⚠ WARNING

Leaking fuel can cause a fire or explosion resulting in serious burns. Make sure the hose joint is installed correctly on the delivery pipe by sliding the joint.

- ★ If it comes off, reinstall the hose joint.
- Connect the fuel pump, meter and the fuel level sensor connectors and the battery (-) cable terminal.

Fuel Tank

Fuel Tank and Cap Inspection

- Visually inspect the gasket [A] on the tank cap for any damage.
- ★ Replace the gasket if it is damaged.
- Check to see if the breather pipe [B] (CAL, TH and SEA-B1 models) in the tank is not clogged.
- ★ If the breather pipe is clogged, blow the breather free with compressed air.

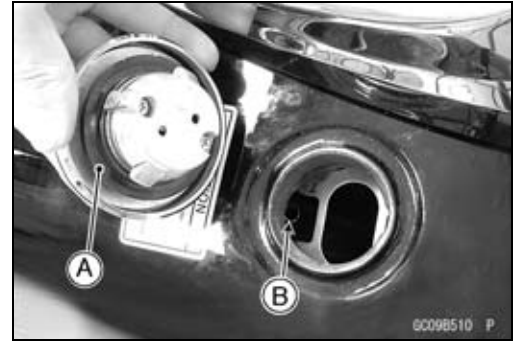

Fuel Tank Cleaning

⚠ WARNING

Gasoline and low flash-point solvents can be flammable and/or explosive and cause severe burns. Clean the tank in a well-ventilated area, and take care that there are no sparks or flame anywhere near the working area. Do not use gasoline or low flash-point solvents to clean the tank.

- Remove the fuel tank (see Fuel Tank Removal).
- Remove the fuel pump from the fuel tank (see Fuel Pump Removal).
- Fill the fuel tank with some high flash-point solvent, and shake the tank to remove dirt and fuel deposits.
- Draw the solvent out of the fuel tank.
- Dry the tank with compressed air.
- Install the fuel pump (see Fuel Pump Installation).
- Install the fuel tank (see Fuel Tank Installation).

Breather Check Valve Inspection

- Remove:
 - Cap [A] and Bolt
 - Ignition Switch [B]
 - Bolt [C]
 - Clamp [D]
 - Breather Hoses
 - Breather Check Valve [E]

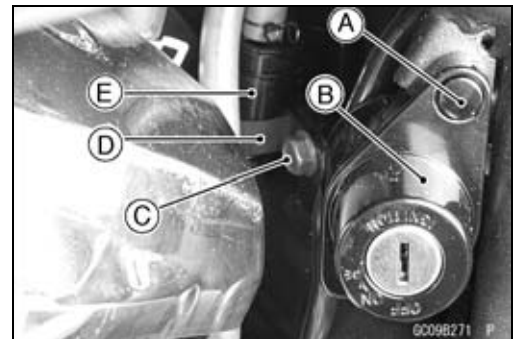

- Check to see if the valve [A] slides smoothly when pushing it in with a wooden or other soft rod, and see if it comes back to its seat by pressure of the spring [B].

NOTE

○ *Inspect the valve in its assembled state. Disassembly and assembly may change the valve performance.*

- ★ If any rough spots are found during above inspection, wash the valve clean with a high flash-point solvent and blow out any foreign particles that may be in the valve with compressed air in a well-ventilated area.
- Take care that there is no spark or flame anywhere near the working area.
- ★ If cleaning does not solve the problem, replace the check valve.

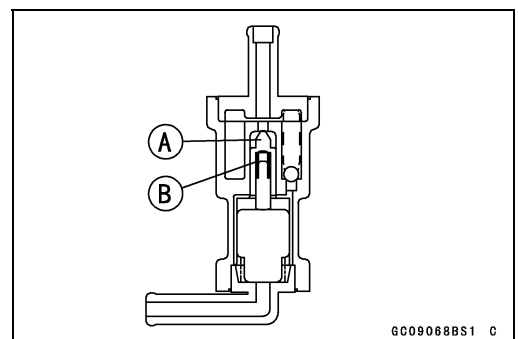

3-140 FUEL SYSTEM (DFI)

Evaporative Emission Control System (CAL, TH and SEA-B1 Models)

The Evaporative Emission Control System routes fuel vapors from the fuel system into the running engine or stores the vapors in a canister when the engine is stopped. Although no adjustments are required, a thorough visual inspection must be made at the intervals specified by the Periodic Maintenance Chart.

Parts Removal/Installation

⚠ WARNING

Gasoline is extremely flammable and can be explosive under certain conditions. Make sure the area is well-ventilated and free from any source of flame or sparks; this includes any appliance with a pilot light. Do not smoke. Turn the ignition switch OFF.

NOTICE

If gasoline, solvent, water or any other liquid enters the canister, the canister's vapor absorbing capacity is greatly reduced. If the canister does become contaminated, replace it with a new one.

- To prevent the gasoline from flowing into or out of the canister, hold the separator perpendicular to the ground.
- Be sure to plug the return hose to prevent fuel spilling before fuel tank removal.

⚠ WARNING

Spilled fuel is flammable and can be explosive under certain conditions. When removing the fuel tank, be careful not to spill fuel through the return hose.

- ★ If liquid or gasoline flows into the breather hose, remove the hose and blow it clean with compressed air.
- Connect the hoses according to the diagram of the system (see Cable, Wire, and Hose Routing section in the Appendix chapter). Make sure they do not get pinched or kinked.
- Route hoses with a minimum of bending so that the air or vapor will not be obstructed.

Hose Inspection

- Refer to the Evaporative Emission Control System Inspection in the Periodic Maintenance chapter.

Canister Inspection

- Refer to the Evaporative Emission Control System Inspection in the Periodic Maintenance chapter.

Separator Inspection

- Refer to the Evaporative Emission Control System Inspection in the Periodic Maintenance chapter.

Evaporative Emission Control System (CAL, TH and SEA-B1 Models)

Separator Operation Test

⚠ WARNING

Gasoline is extremely flammable and can be explosive under certain conditions. Make sure the area is well-ventilated and free from any source of flame or sparks; this includes any appliance with a pilot light. Do not smoke. Turn the ignition switch OFF.

- Remove:
 - Seat (see Seat Removal in the Frame chapter)
 - Left Side Cover (see Left Side Cover Removal in the Frame chapter)
- Connect the hoses to the separator.
- Disconnect the breather hose from the separator, and inject about 20 mL (0.68 US oz.) of gasoline [A] into the separator [B] through the hose fitting.
- Disconnect the evaporative fuel return hose [C] from the fuel tank [D]
- Run the open end of the return hose into the container level with the tank top [E].
- Start the engine, and let it idle.
- ★ If the gasoline in the separator comes out of the hose, the separator works well. If it does not, replace the separator with a new one.

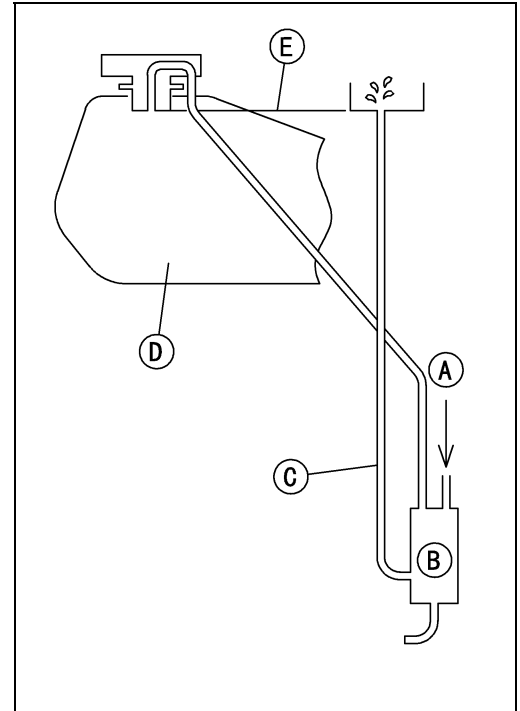

3-142 FUEL SYSTEM (DFI)

Evaporative Emission Control System (CAL, TH and SEA-B1 Models)

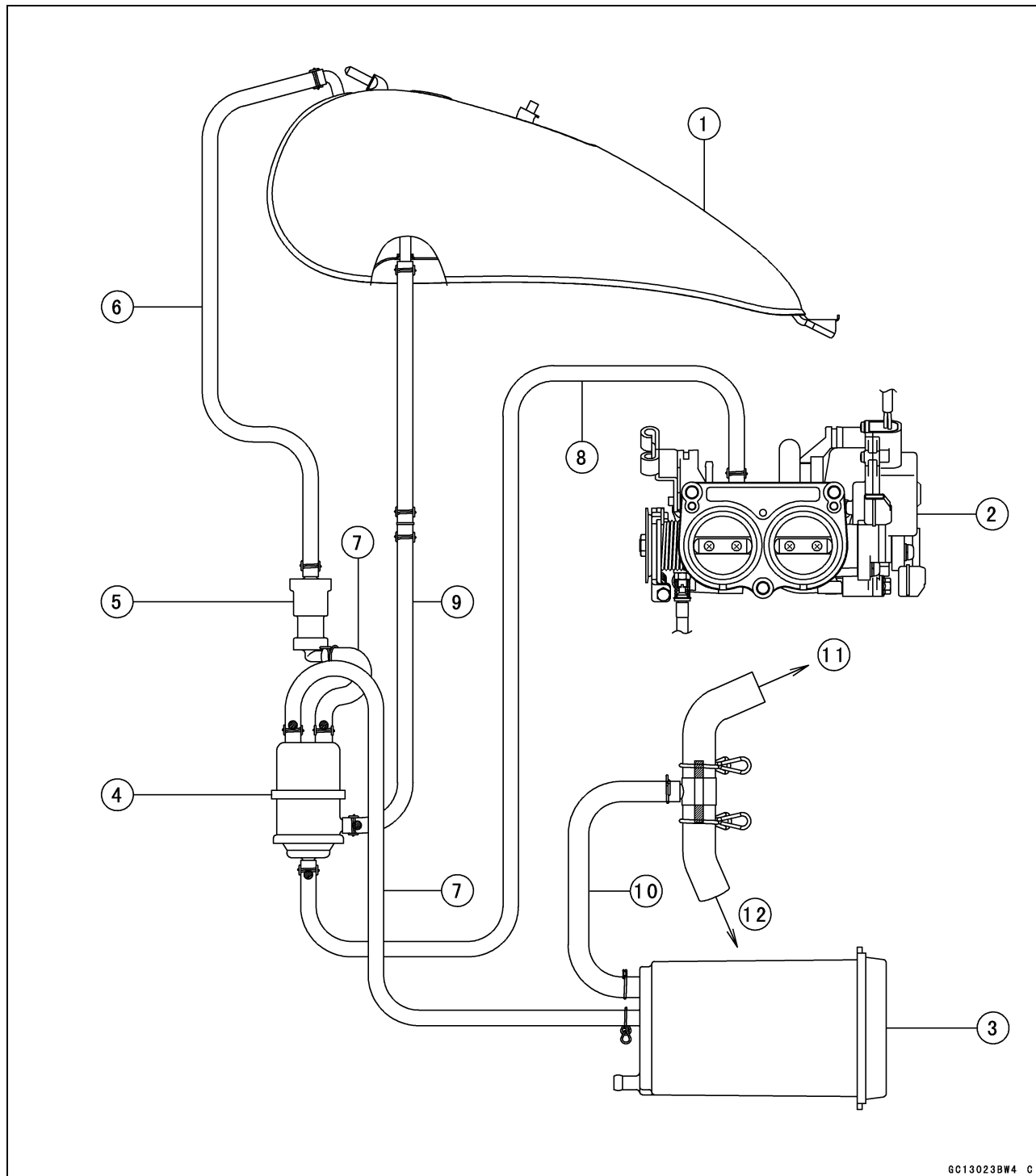

1. Fuel Tank
2. Throttle Body Assy
3. Canister
4. Separator
5. Breather Check Valve
6. Breather Hose
7. Breather Hose (Blue)
8. Vacuum Hose (White)
9. Fuel Return Hose (Red)
10. Purge Hose (Green)
11. To Air Switching Valve
12. To Air Cleaner

Cooling System

Table of Contents

| | |
|---|------|
| Exploded View..... | 4-2 |
| Coolant Flow Chart..... | 4-4 |
| Specifications | 4-6 |
| Special Tools | 4-7 |
| Coolant | 4-8 |
| Coolant Deterioration Inspection..... | 4-8 |
| Coolant Level Inspection..... | 4-8 |
| Coolant Draining | 4-8 |
| Coolant Filling | 4-8 |
| Pressure Testing | 4-8 |
| Cooling System Flushing | 4-9 |
| Reserve Tank Removal..... | 4-9 |
| Water Pump..... | 4-10 |
| Water Pump Impeller Removal | 4-10 |
| Water Pump Impeller Installation | 4-10 |
| Mechanical Seal Replacement | 4-10 |
| Water Pump Inspection..... | 4-12 |
| Radiator, Radiator Fan | 4-13 |
| Radiator and Radiator Fan Removal | 4-13 |
| Radiator Fan Installation | 4-14 |
| Radiator Inspection | 4-14 |
| Radiator Cap Inspection | 4-15 |
| Radiator Filler Neck Inspection | 4-15 |
| Thermostat | 4-16 |
| Thermostat Removal..... | 4-16 |
| Thermostat Installation..... | 4-16 |
| Thermostat Inspection | 4-16 |
| Hose and Pipes | 4-18 |
| Hose Installation | 4-18 |
| Hose Inspection | 4-18 |
| Water Temperature Sensor | 4-19 |
| Water Temperature Sensor Removal/Installation | 4-19 |
| Water Temperature Sensor Inspection | 4-19 |

4-2 COOLING SYSTEM

Exploded View

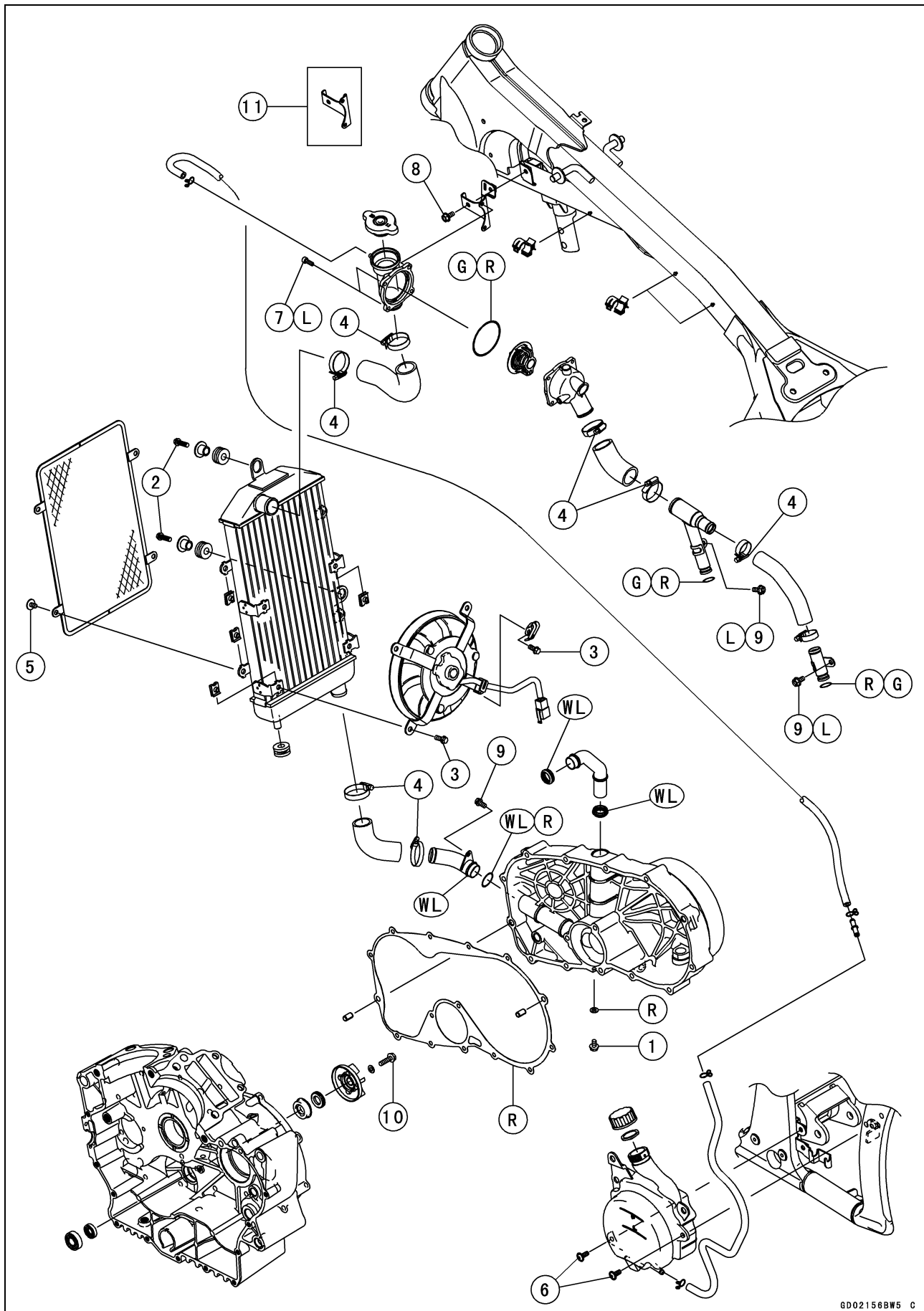

GD021568W5 C

Exploded View

| No. | Fastener | Torque | | | Remarks |
|-----|---------------------------------------|--------|-------|----------|---------|
| | | N·m | kgf·m | ft·lb | |
| 1 | Coolant Drain Bolt | 9.8 | 1.0 | 87 in·lb | |
| 2 | Radiator Bolts | 6.9 | 0.70 | 61 in·lb | |
| 3 | Radiator Fan Bolts | 8.3 | 0.85 | 73 in·lb | |
| 4 | Radiator Hose Clamp Screws | 2.0 | 0.20 | 18 in·lb | |
| 5 | Radiator Screen Screws | 6.9 | 0.70 | 61 in·lb | |
| 6 | Reserve Tank Bolts | 6.9 | 0.70 | 61 in·lb | |
| 7 | Thermostat Housing Cover Bolts | 4.9 | 0.50 | 43 in·lb | L |
| 8 | Thermostat Housing Cover Bracket Bolt | 6.9 | 0.70 | 61 in·lb | |
| 9 | Water Hose Fitting Bolts | 9.8 | 1.0 | 87 in·lb | L |
| 10 | Water Pump Impeller Bolt | 9.8 | 1.0 | 87 in·lb | |

11. VN900C7 ~ CB

G: Apply grease.

L: Apply a non-permanent locking agent.

R: Replacement Parts

WL: Apply soap and water solution.

4-4 COOLING SYSTEM

Coolant Flow Chart

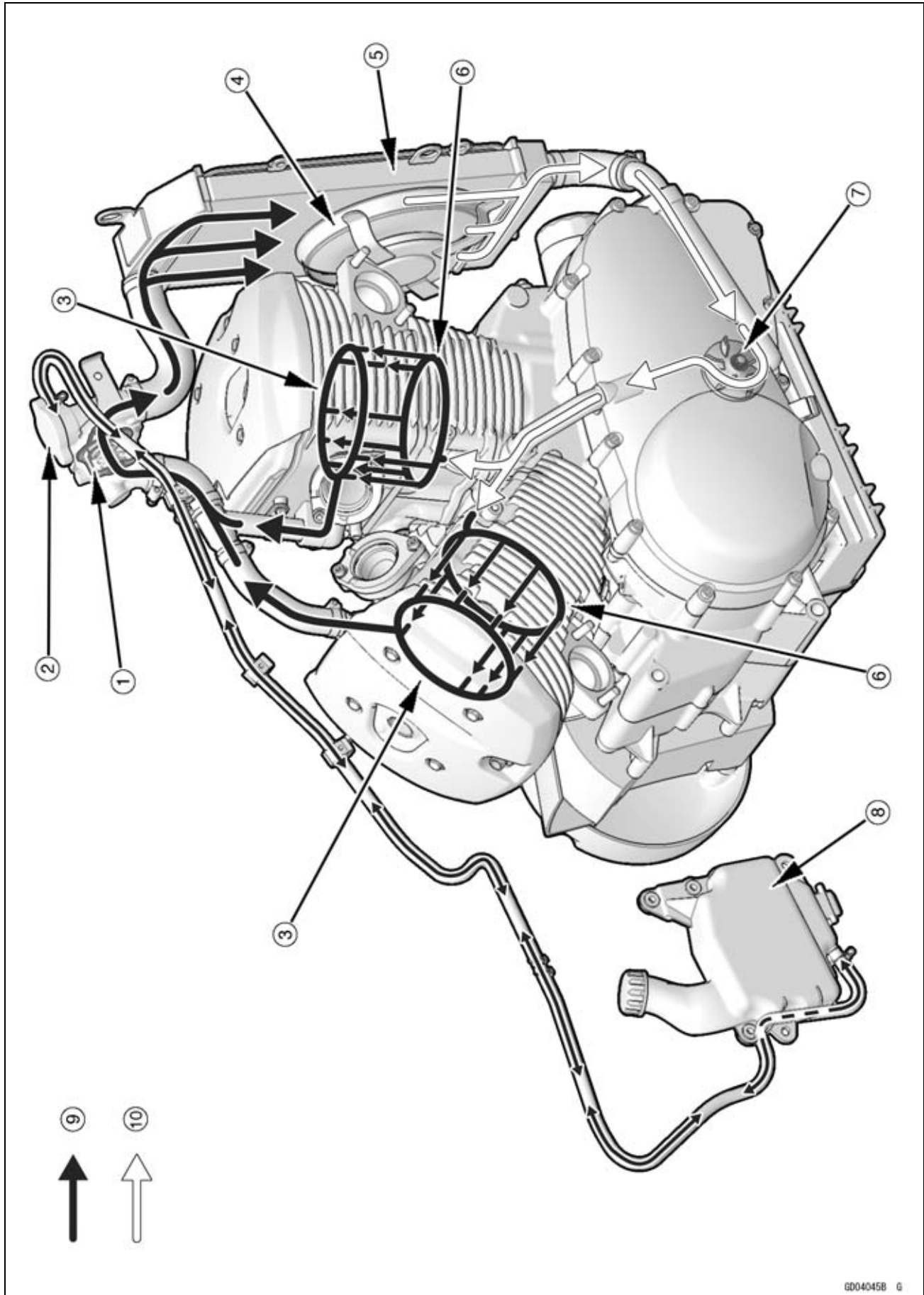

G004045B G

Coolant Flow Chart

1. Thermostat
2. Radiator Cap
3. Cylinder Head Jacket
4. Radiator Fan
5. Radiator
6. Cylinder Jacket
7. Water Pump
8. Reserve Tank
9. Hot Coolant
10. Cold Coolant

Permanent type antifreeze is used as a coolant to protect the cooling system from rust and corrosion. When the engine starts, the water pump turns and the coolant circulates.

The thermostat is a wax pellet type which opens or closes with coolant temperature changes. The thermostat continuously changes its valve opening to keep the coolant temperature at the proper level. When coolant temperature is below 58 ~ 62°C (136 ~ 144°F), the thermostat closes so that the coolant flow is restricted through the air bleeder hole, causing the engine to warm up more quickly. When coolant temperature is more than 58 ~ 62°C (136 ~ 144°F), the thermostat opens and the coolant flows.

When the coolant temperature goes up beyond 100°C (212°F), the radiator fan relay conducts to operate the radiator fan. The radiator fan draws air through the radiator core when there is not sufficient air flow such as at low speeds. This increases up the cooling action of the radiator. When the temperature is 90°C (194°F), the fan relay opens and the radiator fan stops.

In this way, this system controls the engine temperature within narrow limits where the engine operates most efficiently even if the engine load varies.

The system is pressurized by the radiator cap to suppress boiling and the resultant air bubbles which can cause engine overheating. As the engine warms up, the coolant in the radiator and the water jacket expands. The excess coolant flows through the radiator cap and hose to the reserve tank to be stored there temporarily. Conversely, as the engine cools down, the coolant in the radiator and the water jacket contracts, and the stored coolant flows back to the radiator from the reserve tank.

The radiator cap has two valves. One is a pressure valve which holds the pressure in the system when the engine is running. When the pressure exceeds 93 ~ 123 kPa (0.95 ~ 1.25 kgf/cm², 14 ~ 18 psi), the pressure valve opens and releases the pressure to the reserve tank. As soon as pressure escapes, the valve closes, and keeps the pressure at 93 ~ 123 kPa (0.95 ~ 1.25 kgf/cm², 14 ~ 18 psi). When the engine cools down, another small valve (vacuum valve) in the cap opens. As the coolant cools, the coolant contracts to form a vacuum in the system. The vacuum valve opens and allows the coolant from the reserve tank to enter the radiator.

4-6 COOLING SYSTEM

Specifications

| Item | Standard |
|---|---|
| Coolant Provided when Shipping Type (Recommended) Color Mixed Ratio Freezing Point Total Amount | Permanent type of antifreeze (soft water and ethylene glycol plus corrosion and rust inhibitor chemicals for aluminum engines and radiators) Green Soft water 50%, coolant 50% −35°C (−31°F) 2.2 L (2.3 US qt) (reserve tank full level, including radiator and engine) |
| Radiator Cap Relief Pressure | 93 ~ 123 kPa (0.95 ~ 1.25 kgf/cm ² , 13 ~ 18 psi) |
| Thermostat Valve Opening Temperature Valve Full Opening Lift | 58 ~ 62°C (136 ~ 144°F) 8 mm (0.31 in.) or more at 75°C (167°F) |

Special Tools

Bearing Driver Set:
57001-1129

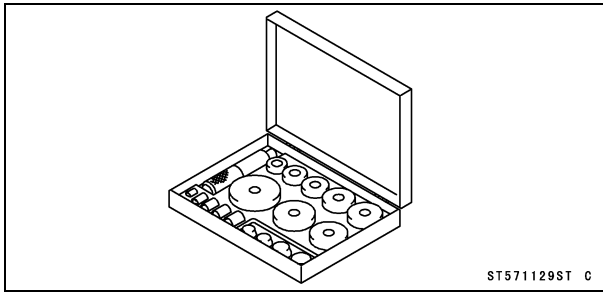

Bearing Remover Head, $\phi 10 \times \phi 12$:
57001-1266

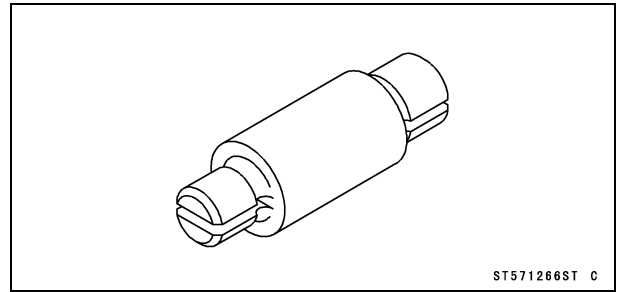

Bearing Remover Shaft, $\phi 9$:
57001-1265

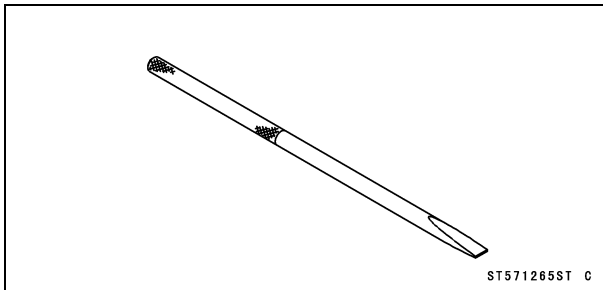

4-8 COOLING SYSTEM

Coolant

Coolant Deterioration Inspection

- Visually inspect the coolant in the reserve tank.
- ★ If whitish cotton-like wafts are observed, aluminum parts in the cooling system are corroded. If the coolant is brown, iron or steel parts are rusting. In either case, flush the cooling system.
- ★ If the coolant gives off an abnormal smell, check for a cooling system leak. It may be caused by exhaust gas leaking into the cooling system.

Coolant Level Inspection

- Refer to the Coolant Level Inspection in the Periodic Maintenance chapter.

Coolant Draining

- Refer to the Coolant Change in the Periodic Maintenance chapter.

Coolant Filling

- Refer to the Coolant Change in the Periodic Maintenance chapter.

Pressure Testing

- Remove the fuel tank (see Fuel Tank Removal in the Fuel System (DFI) chapter).
- Remove the radiator cap, and install a cooling system pressure tester [A] on the filler neck [B].

NOTE

○ Wet the cap sealing surfaces with water or coolant to prevent pressure leaks.

- Build up pressure in the system carefully until the pressure reaches 123 kPa (1.25 kgf/cm², 18 psi).

NOTICE

During pressure testing, do not exceed the pressure for which the system is designed. The maximum pressure is 123 kPa (1.25 kgf/cm², 18 psi).

- Watch the gauge for at least 6 seconds.
- ★ If the pressure holds steady, the system is all right.
- ★ If the pressure drops and no external source is found, check for internal leaks. Droplets in the engine oil indicate internal leakage. Check the cylinder head gasket and the water pump.
- Remove the pressure tester, replenish the coolant, and install the radiator cap.

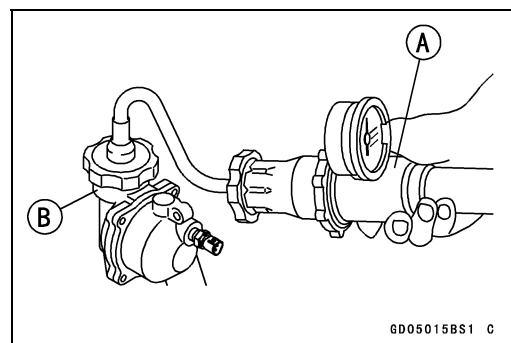

Coolant

Cooling System Flushing

Over a period of time, the cooling system accumulates rust, scale, and lime in the water jacket and radiator. When this accumulation is suspected or observed, flush the cooling system. If this accumulation is not removed, it will clog up the water passage and considerably reduce the efficiency of the cooling system.

- Drain the cooling system (see Coolant Change in the Periodic Maintenance chapter).
- Fill the cooling system with fresh water mixed with a flushing compound.

NOTICE

Do not use a flushing compound which is harmful to the aluminum engine and radiator. Carefully follow the instructions supplied by the manufacturer of the cleaning product.

- Warm up the engine, and run it at normal operating temperature for about ten minutes.
- Stop the engine, and drain the cooling system.
- Fill the system with fresh water.
- Warm up the engine and drain the system.
- Repeat the previous two steps once more.
- Fill the system with a permanent type coolant and bleed the air from the system (see Coolant Change in the Periodic Maintenance chapter).

Reserve Tank Removal

- Remove:
 - Left Side Cover (see Left Side Cover Removal in the Frame chapter)
 - Bolt [A]
 - Reserve Tank Cover [B]
- Remove:
 - Bolts [A]
 - Cap [B]
- Drain the coolant to the suitable container.
- Disconnect the hose [C].

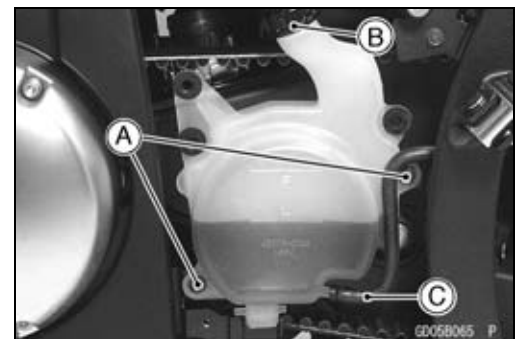

4-10 COOLING SYSTEM

Water Pump

Water Pump Impeller Removal

- Drain:
 - Engine Oil (see Engine Oil Change in the Periodic Maintenance chapter)
 - Coolant (see Coolant Change in the Periodic Maintenance chapter)
- Remove:
 - Right Engine Cover (see Right Engine Cover Removal in the Clutch chapter)
 - Bolt [A] and Washer
 - Impeller [B]

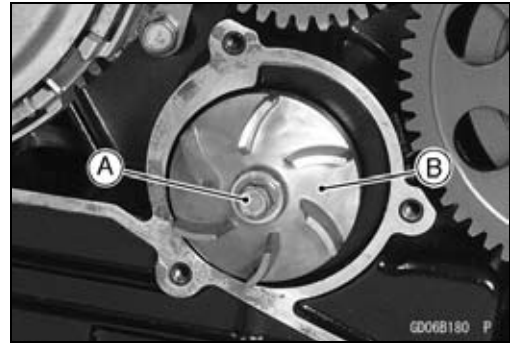

Water Pump Impeller Installation

- Be sure to install the rubber seal [A] and sealing seat [B] into the impeller [C] by hand until the seat bottoms out.
- Apply a little coolant to the sealing seat to give the seal initial lubrication.
- Put the washer on the water pump impeller bolt.
- Tighten:
 - Torque - Water Pump Impeller Bolt: 9.8 N·m (1.0 kgf·m, 87 in·lb)**

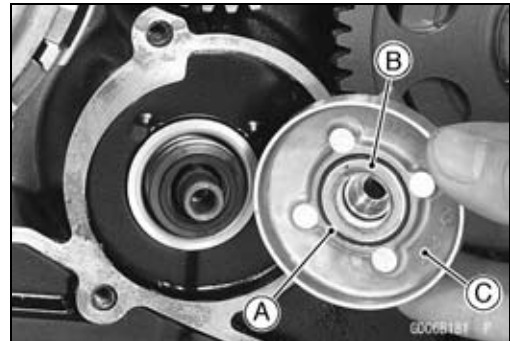

Mechanical Seal Replacement

- Remove the water pump impeller (see Water Pump Impeller Removal).
- Pry the mechanical seal flange [A] off with a small chisel [B].
- Pull the mechanical seal out of the right crankcase with needle nose pliers.

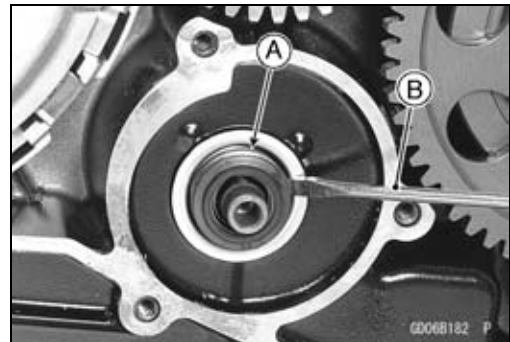

NOTICE

Be careful not to damage the water pump shaft and the inner sealing surface of the crankcase.

- Discard the mechanical seal.

NOTE

○ Since the replacement mechanical seal has an adhesive coated body, do not apply liquid gasket to the exterior surface of the body.

- Press the new mechanical seal [A] into the hole by using a suitable socket [B] and a bearing driver [C] until its flange touches the step [D].

Special Tool - Bearing Driver Set: 57001-1129

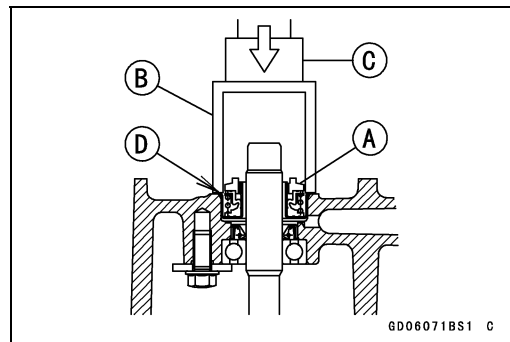

NOTICE

Be careful not to damage the water pump shaft and mechanical seal.

Water Pump

★ If the seal and ball bearing are damaged, replace the mechanical seal, ball bearing and oil seal by splitting the crankcase.

- Split the crankcase (see Crankcase Splitting in the Crankshaft/Transmission chapter).
- Take the bearing [A] out of the right crankcase, using the bearing remover.

Special Tools - Bearing Remover Shaft, $\phi 9$ [B]: 57001-1265
Bearing Remover Head, $\phi 10 \times \phi 12$ [C]: 57001-1266

- Using a thin-bladed screwdriver, pry out the oil seal.
- Press out the mechanical seal [A] from the inside of the right crankcase with the bearing driver set [B].

Special Tool - Bearing Driver Set: 57001-1129

○ Be sure to replace the mechanical seal, oil seal and ball bearing with new ones.

- Apply plenty grease to the oil seal lips.
- Press the oil seal [A] into the hole from the inside of the right crankcase with the bearing driver set so that the spring side of the seal lips is toward the inside of the crankcase.

Special Tool - Bearing Driver Set: 57001-1129

○ Use the bearing driver which has a larger diameter than the oil seal.

- Press in the ball bearing [B] with its manufacturer's mark facing out until it bottoms out.

- Press the mechanical seal [A] by using a suitable socket [B] and a bearing driver [C] until its flange touches the step [D].

Special Tool - Bearing Driver Set: 57001-1129

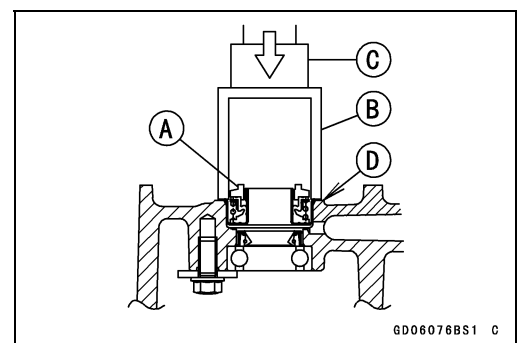
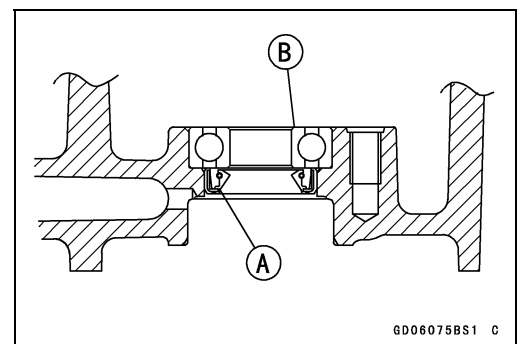
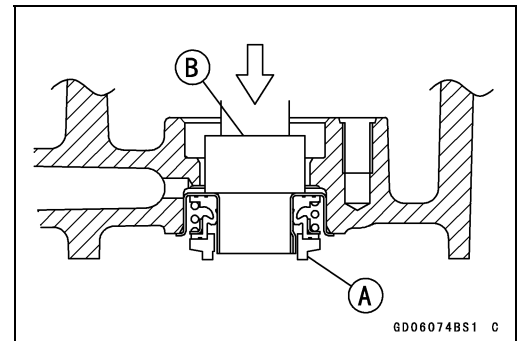
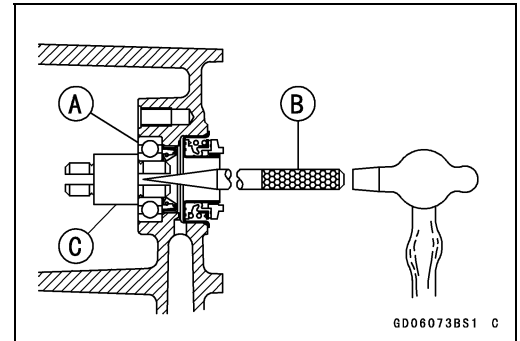

4-12 COOLING SYSTEM

Water Pump

Water Pump Inspection

- Check the drainage outlet passage [A] at the bottom of the right crankcase for coolant leaks.
- If a coolant leak or ooze is found, start the engine and check if the coolant leaks continuously.
- When coolant does not continuously leak, it is normal.
- ★ If the mechanical seal is damaged, the coolant continuously leaks through the drainage outlet passage. Replace the mechanical seal unit (see Mechanical Seal Replacement).
- ★ If the oil seal is damaged, engine oil leaks through the drainage outlet passage. Replace the oil seal.

- Visually inspect the impeller [A].
- ★ If the surface is corroded, or if the blades are damaged, replace the impeller.



Radiator, Radiator Fan

Radiator and Radiator Fan Removal

⚠ WARNING

A spinning radiator fan can cause serious injury. The radiator fan is connected directly to the battery and may start even if the ignition switch is off. Do not touch the radiator fan until it has been disconnected from the battery.

- Drain the coolant (see Coolant Change in the Periodic Maintenance chapter).
- Remove:
 - Seat (see Seat Removal in the Frame chapter)
 - Fuel Tank (see Fuel Tank Removal in the Fuel System (DFI) chapter)
 - Radiator Hose Clamp Screw [A] (Loosen)
- Disconnect the radiator hose [B].

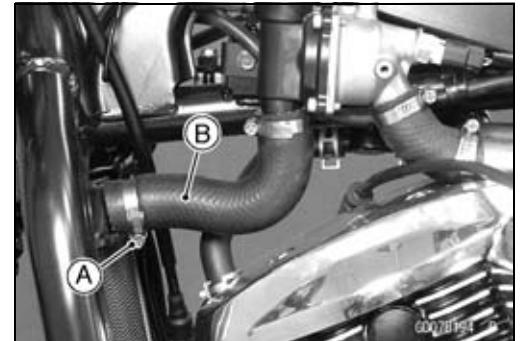

- Loosen the radiator hose clamp screw [A].
- Disconnect the radiator hose [B].
- Remove the radiator bolt [C].

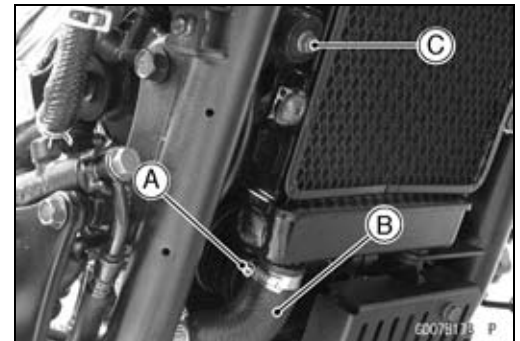

- Remove:
 - Horn Lead Connectors [A]
 - Bolt [B]
 - Horn [C]
 - Radiator Bolt [D]

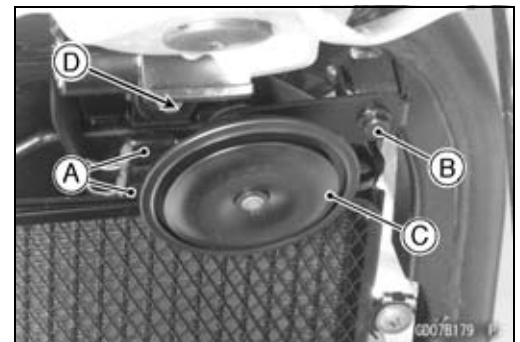

- Pry open the clamps [A].



4-14 COOLING SYSTEM

Radiator, Radiator Fan

- Remove:
 - Radiator Fan Connector [A]
 - Radiator

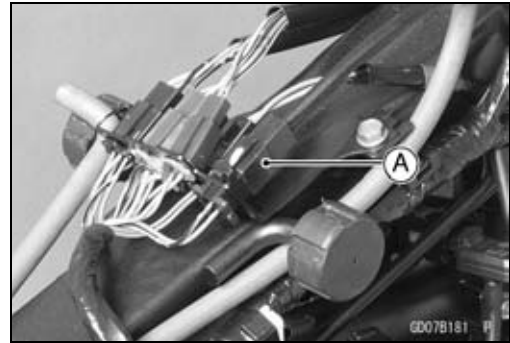

- Remove:
 - Radiator Fan Bolts [A]
 - Radiator Fan [B]

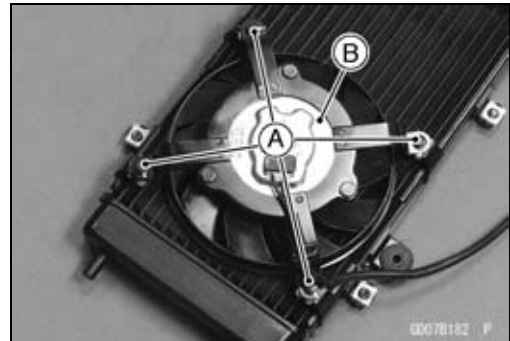

NOTICE

Do not touch the radiator core. This could damage the radiator fins, resulting in loss of cooling efficiency.

Radiator Fan Installation

- Tighten the radiator fan bolts.
 - Torque - Radiator Fan Bolts: 8.3 N·m (0.85 kgf·m, 73 in·lb)
- Fit the radiator stopper [A] into the grommet [B].
- Tighten:
 - Torque - Radiator Hose Clamp Screws: 2.0 N·m (0.20 kgf·m, 18 in·lb)
 - Radiator Screen Screws: 6.9 N·m (0.70 kgf·m, 61 in·lb)

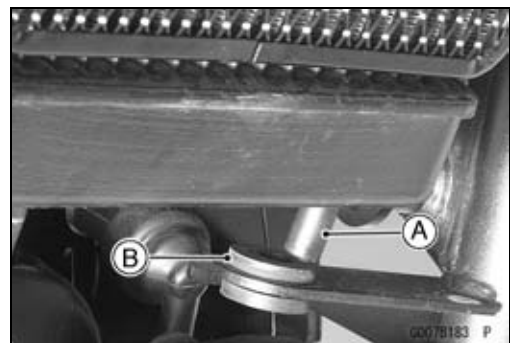

Radiator Inspection

- Check the radiator core.
- ★ If there are obstructions to air flow, remove them.
- ★ If the corrugated fins [A] are deformed, carefully straighten them.
- ★ If the air passages of the radiator core are blocked more than 20% by unremovable obstructions or irreparably deformed fins, replace the radiator with a new one.

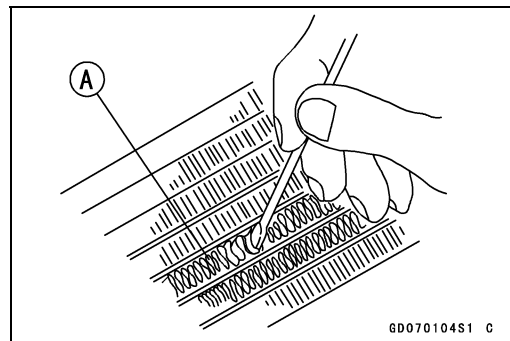

NOTICE

When cleaning the radiator with steam cleaner, be careful of the following to prevent radiator damage. Keep the steam gun [A] away more than 0.5 m (1.6 ft) [B] from the radiator core. Hold the steam gun perpendicular [C] (not oblique [D]) to the core surface. Run the steam gun, following the core fin direction.

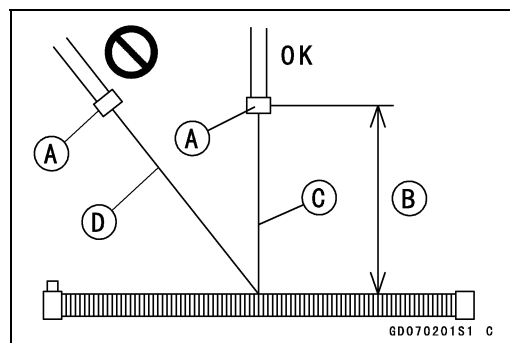

Radiator, Radiator Fan

Radiator Cap Inspection

- Remove the radiator cap (see Coolant Change in the Periodic Maintenance chapter).
- Check the condition of the bottom [A] and top [B] valve seals and valve spring [C].
- ★ If any one of them shows visible damage, replace the cap with a new one.

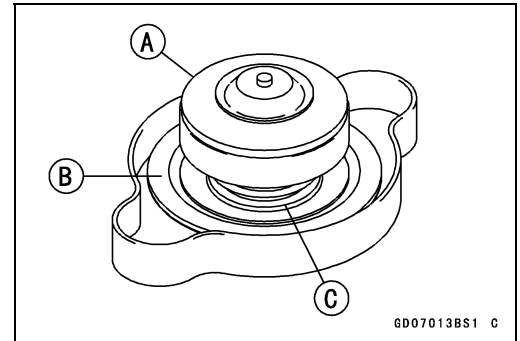

- Install the cap [A] on a cooling system pressure tester [B].

NOTE

○ *Wet the cap sealing surfaces with water or coolant to prevent pressure leaks.*

- Watching the pressure gauge, pump the pressure tester to build up the pressure until the relief valve opens: the gauge needle flicks downward. Stop pumping and measure leak time at once. The relief valve must open within the specified range in the table below and the gauge hand must remain within the same range at least 6 seconds.

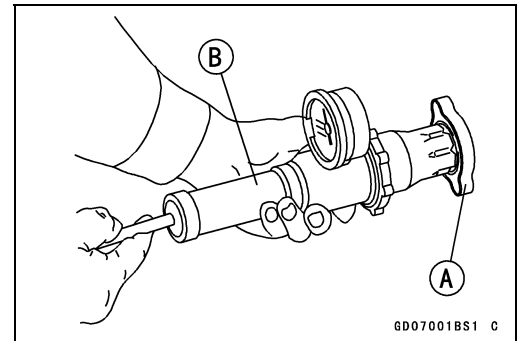

Radiator Cap Relief Pressure

Standard: 93 ~ 123 kPa (0.95 ~ 1.25 kgf/cm², 13 ~ 18 psi)

- ★ If the cap can not hold the specified pressure or if it holds too much pressure, replace it with a new one.

Radiator Filler Neck Inspection

- Remove the radiator cap (see Coolant Change in the Periodic Maintenance chapter).
- Check the radiator filler neck for signs of damage.
- Check the condition of the top and bottom sealing seats [A] in the filler neck. They must be smooth and clean for the radiator cap to function properly.



4-16 COOLING SYSTEM

Thermostat

Thermostat Removal

- Drain the coolant (about 200 mL) (see Coolant Change in the Periodic Maintenance chapter).
- Remove:
 - Seat (see Seat Removal in the Frame chapter)
 - Fuel Tank (see Fuel Tank Removal in the Fuel System (DFI) chapter)
- Disconnect the reserve tank hose [A].
- Loosen the radiator hose clamp screws [B].
- Disconnect the water temperature sensor lead connector [C].
- Remove the bolt [D].

- Remove:
 - Thermostat Housing Cover Bolts [A]
 - Thermostat Housing Cover
 - Thermostat

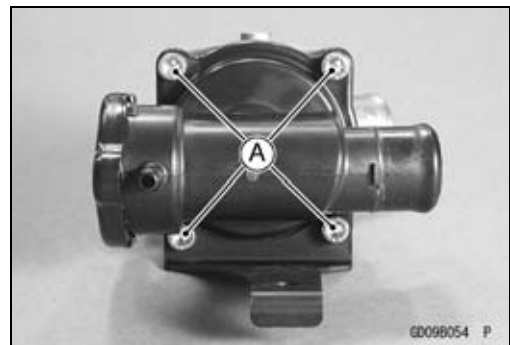

Thermostat Installation

- Install a new O-ring [A] into the housing cover.
- Install:
 - Thermostat
 - Thermostat Housing Cover
- Apply a non-permanent locking agent to the threads of the bolts, and tighten them.
Torque - Thermostat Housing Cover Bolts: 4.9 N·m (0.50 kgf·m, 43 in·lb)
- Fill the radiator with coolant (see Coolant Change in the Periodic Maintenance chapter).
- Install the removed parts (see appropriate chapters).

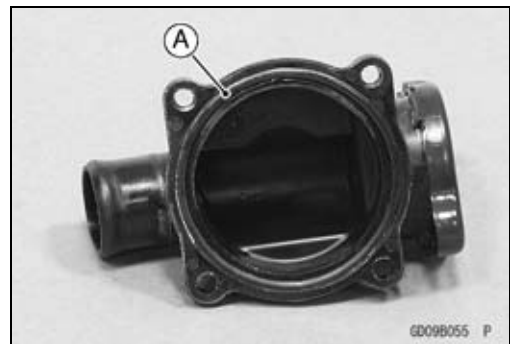

Thermostat Inspection

- Remove the thermostat (see Thermostat Removal), and inspect the thermostat valve [A] at room temperature.
- ★ If the valve is open, replace the thermostat with a new one.

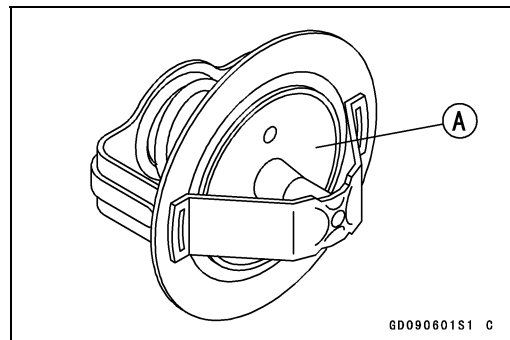

Thermostat

- To check valve opening temperature, suspend the thermostat [A] in a container of water and raise the temperature of the water.
- The thermostat must be completely submerged and must not touch the container sides or bottom. Suspend an accurate thermometer [B] in the water so that the heat sensitive portions [C] are located in almost the same depth. It must not touch the container, either.
- ★ If the measurement is out of the specified range, replace the thermostat with a new one.

Thermostat Valve Opening Temperature

Standard: 58 ~ 62°C (136 ~ 144°F)

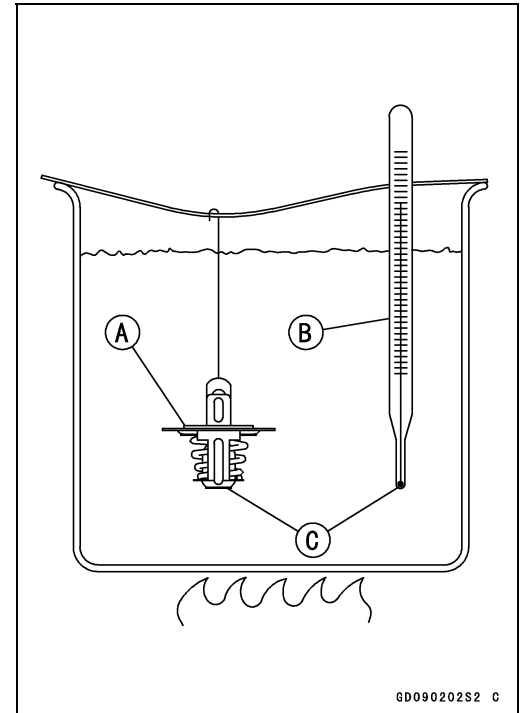

GD090202S2 C

4-18 COOLING SYSTEM

Hose and Pipes

Hose Installation

- Install the hoses and pipes being careful to follow bending direction. Avoid sharp bending, kinking, flattening or twisting.
- Run the hoses (see Cable, Wire, and Hose Routing section in the Appendix chapter).
- Install the clamp [A] as near as possible to the hose end to clear the raised rib of the fitting. This will prevent the hoses from working loose.
- The clamp screws should be positioned correctly to prevent the clamps from contacting the other parts.

Torque - Radiator Hose Clamp Screws: 2.0 N·m (0.20 kgf·m, 18 in·lb)

Hose Inspection

- Refer to the Radiator Hose Damage and Installation Condition Inspection in the Periodic Maintenance chapter.

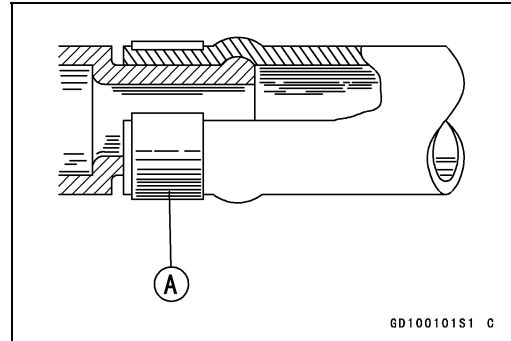

Water Temperature Sensor

| |
|----------------------|
| <i>NOTICE</i> |
|----------------------|

| |
|--|
| <p>The water temperature sensor should never be allowed to fall on a hard surface. Such a shock to the water temperature sensor can damage it.</p> |
|--|

Water Temperature Sensor Removal/Installation

- Refer to the Water Temperature Sensor Removal/Installation in the Fuel System (DFI) chapter.

Water Temperature Sensor Inspection

- Refer to the Water Temperature Sensor Inspection in the Electrical System chapter.

Engine Top End

Table of Contents

| | | | |
|--------------------------------------|------|------------------------------------|------|
| Exploded View..... | 5-2 | Cylinder Heads..... | 5-25 |
| Exhaust System Identification | 5-6 | Cylinder Compression | |
| Specifications | 5-9 | Measurement | 5-25 |
| Special Tools | 5-11 | Cylinder Head Removal..... | 5-26 |
| Clean Air System..... | 5-14 | Cylinder Head Installation..... | 5-26 |
| Air Suction Valve Removal..... | 5-14 | Cylinder Head Warp Inspection ... | 5-26 |
| Air Suction Valve Installation..... | 5-14 | Valves | 5-27 |
| Air Suction Valve Inspection | 5-14 | Valve Clearance Inspection | 5-27 |
| Air Switching Valve Removal | 5-14 | Valve Clearance Adjustment..... | 5-27 |
| Air Switching Valve Installation ... | 5-14 | Valve Removal | 5-27 |
| Air Switching Valve Operation | | Valve Installation | 5-27 |
| Test..... | 5-14 | Valve Guide Removal | 5-27 |
| Air Switching Valve Unit Test | 5-14 | Valve Guide Installation | 5-28 |
| Clean Air System Hose | | Valve-to-Guide Clearance | |
| Inspection..... | 5-15 | Measurement (Wobble | |
| Cylinder Head Covers | 5-16 | Method)..... | 5-28 |
| Cylinder Head Cover Removal ... | 5-16 | Valve Seat Inspection | 5-29 |
| Cylinder Head Cover Installation . | 5-17 | Valve Seat Repair | 5-29 |
| Camshaft Chain Tensioners | 5-18 | Cylinders, Pistons..... | 5-34 |
| Camshaft Chain Tensioner | | Cylinder Removal..... | 5-34 |
| Removal..... | 5-18 | Piston Removal..... | 5-34 |
| Camshaft Chain Tensioner | | Cylinder, Piston Installation..... | 5-34 |
| Installation..... | 5-18 | Cylinder Wear Inspection..... | 5-36 |
| Camshafts, Camshaft Chains..... | 5-19 | Piston Wear Inspection | 5-36 |
| Camshaft Removal | 5-19 | Piston/Cylinder Clearance | |
| Camshaft Installation | 5-20 | Inspection..... | 5-36 |
| Camshaft, Camshaft Cap Wear | | Piston Ring, Piston Ring Groove | |
| Inspection..... | 5-21 | Wear Inspection | 5-37 |
| Camshaft Runout Inspection..... | 5-22 | Piston Ring Groove Width | |
| Cam Wear Inspection | 5-22 | Inspection..... | 5-37 |
| Camshaft Chain Removal | 5-22 | Piston Ring Thickness Inspection | 5-37 |
| Camshaft and Sprocket | | Piston Ring End Gap Inspection .. | 5-38 |
| Assembly..... | 5-23 | Mufflers..... | 5-39 |
| Rocker Shafts, Rocker Arms | 5-24 | Muffler Removal..... | 5-39 |
| Rocker Shaft, Rocker Arm | | Muffler Installation..... | 5-40 |
| Removal..... | 5-24 | | |
| Rocker Shaft, Rocker Arm | | | |
| Installation | 5-24 | | |

5-2 ENGINE TOP END

Exploded View

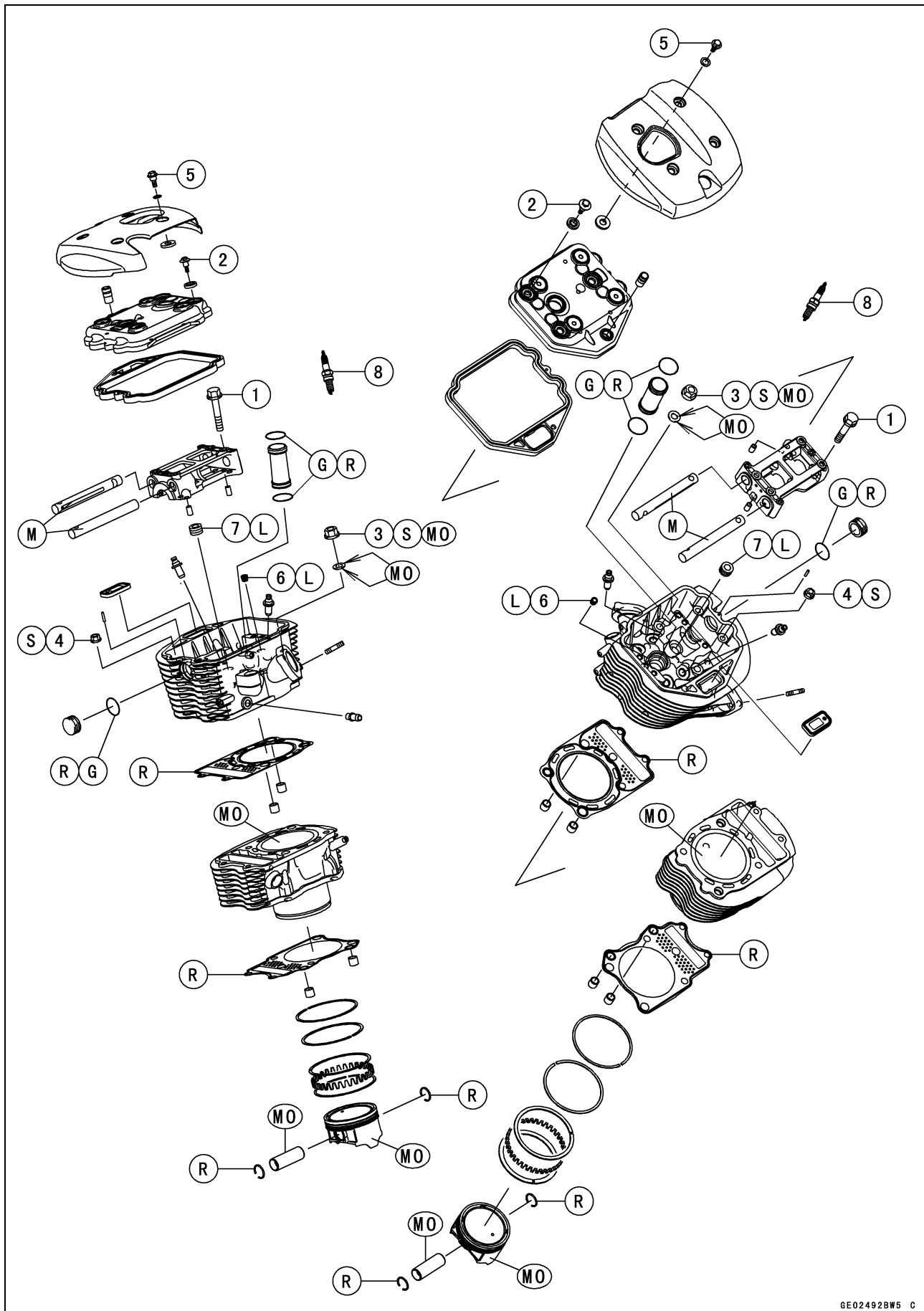

GE024928W5 C

Exploded View

| No. | Fastener | Torque | | | Remarks |
|-----|----------------------------------|--------|-------|-----------|---------|
| | | N·m | kgf·m | ft·lb | |
| 1 | Camshaft Cap Bolts | 25 | 2.5 | 18 | |
| 2 | Cylinder Head Cover Bolts | 12 | 1.2 | 106 in·lb | |
| 3 | Cylinder Head Nuts (M10) (First) | 20 | 2.0 | 15 | MO, S |
| | Cylinder Head Nuts (M10) (Final) | 49 | 5.0 | 36 | MO, S |
| 4 | Cylinder Head Nuts (M8) | 25 | 2.5 | 18 | S |
| 5 | Cylinder Head Outer Cover Bolts | 9.8 | 1.0 | 87 in·lb | |
| 6 | Plug (PT1/4) | 15 | 1.5 | 11 | L |
| 7 | Plug (PT1/2) | 20 | 2.0 | 15 | L |
| 8 | Spark Plugs | 18 | 1.8 | 13 | |

G: Apply grease.

L: Apply a non-permanent locking agent.

M: Apply molybdenum disulfide grease.

MO: Apply molybdenum disulfide oil solution.

(mixture of the engine oil and molybdenum disulfide grease in a weight ratio 10 : 1)

R: Replacement Parts

S: Follow the specified tightening sequence.

5-4 ENGINE TOP END

Exploded View

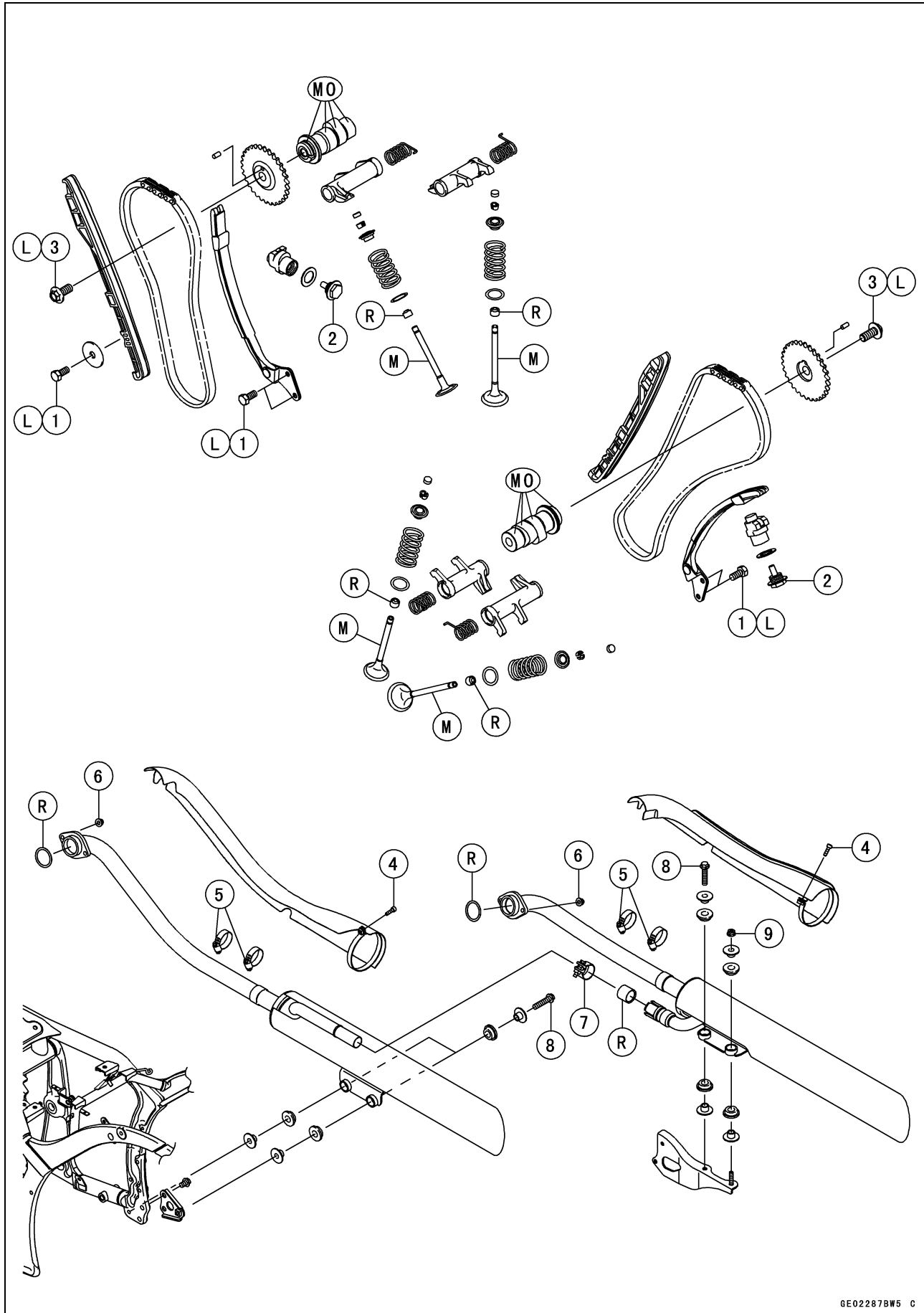

GE022878W5 C

Exploded View

| No. | Fastener | Torque | | | Remarks |
|-----|------------------------------------|--------|-------|----------|---------|
| | | N·m | kgf·m | ft·lb | |
| 1 | Camshaft Chain Guide Bolts | 9.8 | 1.0 | 87 in·lb | L |
| 2 | Camshaft Chain Tensioner Cap Bolts | 20 | 2.0 | 15 | |
| 3 | Camshaft Sprocket Bolts | 49 | 5.0 | 36 | L |
| 4 | Exhaust Pipe Cover Bolts | 6.9 | 0.70 | 61 in·lb | |
| 5 | Exhaust Pipe Cover Clamp Bolts | 6.9 | 0.70 | 61 in·lb | |
| 6 | Exhaust Pipe Holder Nuts | 17 | 1.7 | 12 | |
| 7 | Muffler Joint Clamp Bolt | 17 | 1.7 | 12 | |
| 8 | Muffler Mounting Bolts | 25 | 2.5 | 18 | |
| 9 | Muffler Mounting Nut | 25 | 2.5 | 18 | |

L: Apply a non-permanent locking agent.

M: Apply molybdenum disulfide grease.

MO: Apply molybdenum disulfide oil solution.

(mixture of the engine oil and molybdenum disulfide grease in a weight ratio 10 : 1)

R: Replacement Parts

5-6 ENGINE TOP END

Exhaust System Identification

Exhaust System

| MANIFOLD | MUFFLER BODY | SPECIFICATION | MODEL |
|---|--|--|--|
| Muffler without Boss for Oxygen Sensor | Honeycomb Type Catalyst P/No. 18087-0116 P/No. 18087-0123 Mark: – | U.S.A U.S.A (California) Canada | VN900C7 ~ C8 VN900C7 VN900C7 ~ C8 |
| | Honeycomb Type Catalyst P/No. 18087-0143 P/No. 18087-0144 Mark: – | U.S.A U.S.A (California) Canada S.E.Asia-B1 | VN900C9 ~ CB VN900C8 ~ CB VN900C9 ~ CB VN900C8 |
| | Honeycomb Type Catalyst P/No. 18087-0132 P/No. 18087-0133 Mark: – | Australia | VN900C7 ~ C8 |
| | Honeycomb Type Catalyst P/No. 18087-0191 P/No. 18087-0192 Mark: – | U.S.A U.S.A (California) Canada | VN900C9A, CBA VN900C9A, CBA VN900C9A, CBA |
| | Honeycomb Type Catalyst P/No. 18087-0281 P/No. 18087-0282 Mark: KHI 519 | U.S.A. U.S.A.(California) Canada | VN900CC ~ CD VN900CC ~ CD VN900CC ~ CD |
| | Honeycomb Type Catalyst P/No. 18087-0290 P/No. 18087-0291 Mark: KHI 519 | U.S.A. U.S.A.(California) Canada | VN900CCA ~ VN900CCA ~ VN900CCA ~ |
| Muffler with Boss for Oxygen Sensor | Honeycomb Type Catalyst P/No. 18087-0130 P/No. 18087-0131 Mark: KHI K 500 | WVTA (FULL H) GB WVTA (FULL H) Thailand | VN900C7 ~ C8 VN900C7 ~ C8 VN900C8 |
| | Honeycomb Type Catalyst P/No. 18087-0178 P/No. 18087-0179 Mark: KHI K 540 | Australia WVTA (FULL H) GB WVTA (FULL H) S.E.Asia-B1 Thailand Philippines Brazil | VN900C9 ~ CB VN900C9 ~ CA VN900C9 ~ CA VN900C9 ~ CB VN900C9 ~ CA VN900CA VN900CA |
| | Honeycomb Type Catalyst P/No. 18087-0194 P/No. 18087-0195 Mark: KHI K 540 | Australia WVTA (FULL H) GB WVTA (FULL H) S.E.Asia-B1 Thailand Philippines Brazil | VN900C9A, CBA VN900C9A, CB VN900C9A, CB VN900CBA VN900C9A, CB VN900CB VN900CB |

Exhaust System Identification

| | | | |
|--|--|---|---|
| | Honeycomb Type Catalyst P/No. 18087-0283 P/No. 18087-0284 Mark: KHI 540 | Australia S.E.Asia-B1 WVTA (FULL H) GB WVTA (FULL H) Brazil | VN900CC ~ VN900CC ~ VN900CE VN900CE VN900CE ~ |
| | Honeycomb Type Catalyst P/No. 18087-0292 P/No. 18087-0293 Mark: KHI K 540 | Australia WVTA (FULL H) GB WVTA (FULL H) S.E.Asia-B1 S.E.Asia-B3 Thailand Philippines Brazil | VN900CDA ~ CEA VN900CCA, CD, CEA ~ VN900CCA, CD, CEA ~ VN900CCA ~ CEA VN900CE VN900CCA, CD ~ VN900CCA, CD ~ VN900CC ~, CD, CEA |

WVTA (FULL H): WVTA Model with Honeycomb Catalytic Converter (Full Power)

GB WVTA (FULL H): WVTA Model with Honeycomb Catalytic Converter (Left Side Traffic, Full Power)

GB: United Kingdom Model

5-8 ENGINE TOP END

Exhaust System Identification

Muffler Mark Position [A]

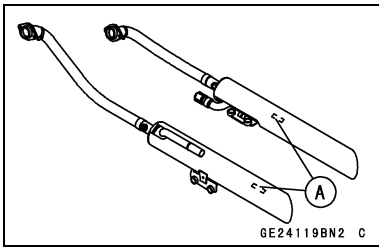

Honeycomb Type Catalyst Position [B]

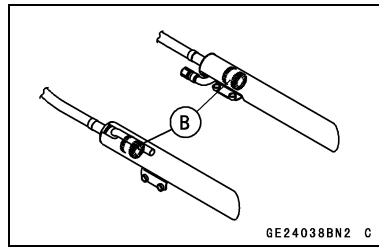

Muffler with Boss [A] for Oxygen Sensor (Oxygen Sensor Equipped Models and AU model [VN900C9 ~])

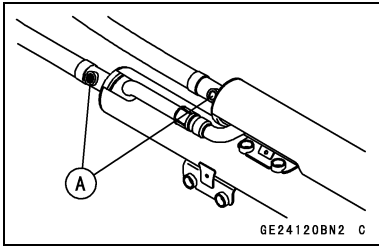

Specifications

| Item | Standard | Service Limit |
|--|--|-------------------------|
| Camshafts | | |
| Cam Height: | | |
| Exhaust | 35.030 ~ 35.144 mm (1.3791 ~ 1.3836 in.) | 34.93 mm (1.375 in.) |
| Inlet | 35.302 ~ 35.416 mm (1.3898 ~ 1.3943 in.) | 35.20 mm (1.386 in.) |
| Camshaft Journal, Camshaft Cap Clearance | 0.028 ~ 0.071 mm (0.0011 ~ 0.0028 in.) | 0.16 mm (0.0063 in.) |
| Camshaft Journal Diameter | 26.950 ~ 26.972 mm (1.0610 ~ 1.0619 in.) | 26.92 mm (1.060 in.) |
| Camshaft Bearing Inside Diameter | 27.000 ~ 27.021 mm (1.0630 ~ 1.0638 in.) | 27.08 mm (1.066 in.) |
| Camshaft Runout | TIR 0.02 mm (0.0008 in.) or less | TIR 0.1 mm (0.004 in.) |
| Rocker Arm Inside Diameter | 16.000 ~ 16.018 mm (0.62992 ~ 0.63063 in.) | 16.05 mm (0.6319 in.) |
| Rocker Shaft Diameter | 15.965 ~ 15.984 mm (0.62854 ~ 0.62929 in.) | 15.94 mm (0.6276 in.) |
| Cylinder Heads | | |
| Cylinder Compression | (Usable Range) 980 ~ 1 570 kPa (10.0 ~ 16.0 kgf/cm ² , 142 ~ 228 psi) at 470 r/min (rpm) | — — — |
| Cylinder Head Warp | — — — | 0.05 mm (0.002 in.) |
| Valves | | |
| Valve Clearance: | | |
| Exhaust | 0.20 ~ 0.25 mm (0.0079 ~ 0.0098 in.) | — — — |
| Inlet | 0.10 ~ 0.15 mm (0.0039 ~ 0.0059 in.) | — — — |
| Valve Head Thickness: | | |
| Exhaust | 0.8 mm (0.03 in.) | 0.5 mm (0.02 in.) |
| Inlet | 0.5 mm (0.02 in.) | 0.3 mm (0.01 in.) |
| Valve Stem Bend | TIR 0.01 mm (0.0004 in.) or less | TIR 0.05 mm (0.002 in.) |
| Valve Stem Diameter: | | |
| Exhaust | 4.955 ~ 4.970 mm (0.1951 ~ 0.1957 in.) | 4.94 mm (0.194 in.) |
| Inlet | 4.975 ~ 4.990 mm (0.1959 ~ 0.1964 in.) | 4.96 mm (0.195 in.) |
| Valve Guide Inside Diameter: | | |
| Exhaust | 5.000 ~ 5.012 mm (0.1968 ~ 0.1973 in.) | 5.08 mm (0.200 in.) |
| Inlet | 5.000 ~ 5.012 mm (0.1968 ~ 0.1973 in.) | 5.08 mm (0.200 in.) |
| Valve/Valve Guide Clearance (Wobble Method): | | |
| Exhaust | 0.09 ~ 0.17 mm (0.0035 ~ 0.0067 in.) | 0.38 mm (0.015 in.) |
| Inlet | 0.03 ~ 0.11 mm (0.0012 ~ 0.0043 in.) | 0.32 mm (0.013 in.) |
| Valve Seat Cutting Angle | 32°, 45°, 60° | — — — |
| Valve Seating Surface: | | |
| Width: | | |
| Exhaust | 0.5 ~ 1.0 mm (0.02 ~ 0.04 in.) | — — — |
| Inlet | 0.5 ~ 1.0 mm (0.02 ~ 0.04 in.) | — — — |

5-10 ENGINE TOP END

Specifications

| Item | Standard | Service Limit |
|-------------------------------|--|----------------------|
| Outside Diameter: | | |
| Exhaust | 26.9 ~ 27.1 mm (1.059 ~ 1.067 in.) | — — — |
| Inlet | 30.9 ~ 31.1 mm (1.216 ~ 1.224 in.) | — — — |
| Valve Spring Free Length: | | |
| Exhaust | 40.5 mm (1.59 in.) | 38.6 mm (1.52 in.) |
| Inlet | 40.5 mm (1.59 in.) | 38.6 mm (1.52 in.) |
| Cylinders, Pistons | | |
| Cylinder Inside Diameter | 88.000 ~ 88.012 mm (3.4646 ~ 3.4650 in.) | 88.10 mm (3.468 in.) |
| Piston Diameter | 87.955 ~ 87.970 mm (3.4628 ~ 3.4634 in.) | 87.80 mm (3.457 in.) |
| Piston/Cylinder Clearance | 0.030 ~ 0.057 mm (0.0012 ~ 0.0022 in.) | — — — |
| Piston Ring/Groove Clearance: | | |
| Top | 0.05 ~ 0.09 mm (0.002 ~ 0.004 in.) | 0.19 mm (0.0075 in.) |
| Second | 0.03 ~ 0.07 mm (0.001 ~ 0.003 in.) | 0.17 mm (0.0067 in.) |
| Piston Ring Groove Width: | | |
| Top | 1.04 ~ 1.06 mm (0.0409 ~ 0.0417 in.) | 1.14 mm (0.0449 in.) |
| Second | 1.02 ~ 1.04 mm (0.0402 ~ 0.0409 in.) | 1.12 mm (0.0441 in.) |
| Piston Ring Thickness: | | |
| Top | 0.97 ~ 0.99 mm (0.038 ~ 0.039 in.) | 0.90 mm (0.035 in.) |
| Second | 0.97 ~ 0.99 mm (0.038 ~ 0.039 in.) | 0.90 mm (0.035 in.) |
| Piston Ring End Gap: | | |
| Top | 0.20 ~ 0.35 mm (0.008 ~ 0.014 in.) | 0.6 mm (0.02 in.) |
| Second | 0.40 ~ 0.55 mm (0.016 ~ 0.022 in.) | 0.8 mm (0.03 in.) |
| Oil | 0.20 ~ 0.70 mm (0.008 ~ 0.028 in.) | 1.0 mm (0.04 in.) |

Special Tools

Compression Gauge, 20 kgf/cm²:
57001-221

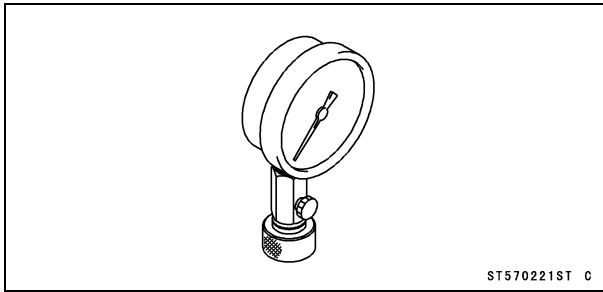

Valve Seat Cutter, 32° - φ28:
57001-1119

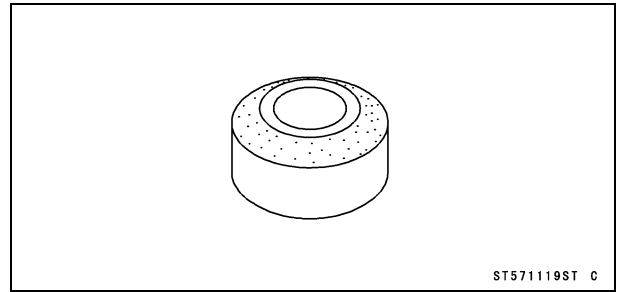

Valve Spring Compressor Assembly:
57001-241

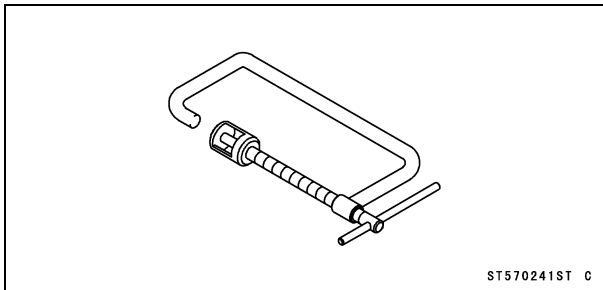

Valve Seat Cutter, 60° - φ30:
57001-1123

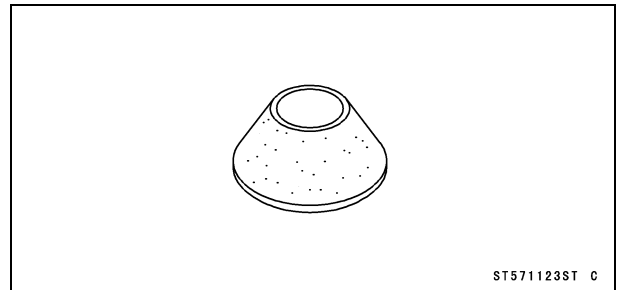

Piston Pin Puller Assembly:
57001-910

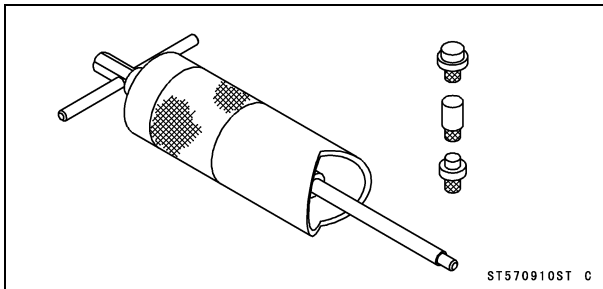

Valve Seat Cutter Holder Bar:
57001-1128

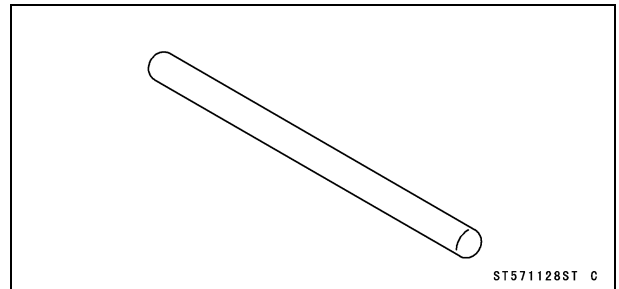

Piston Ring Compressor Grip:
57001-1095

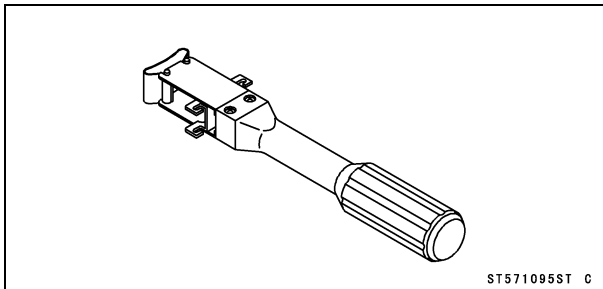

Valve Seat Cutter, 45° - φ30:
57001-1187

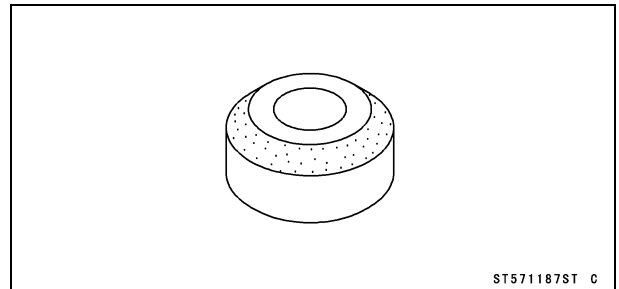

Valve Seat Cutter, 45° - φ32:
57001-1115

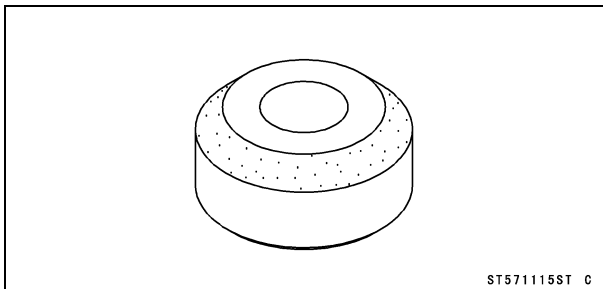

Valve Seat Cutter, 32° - φ33:
57001-1199

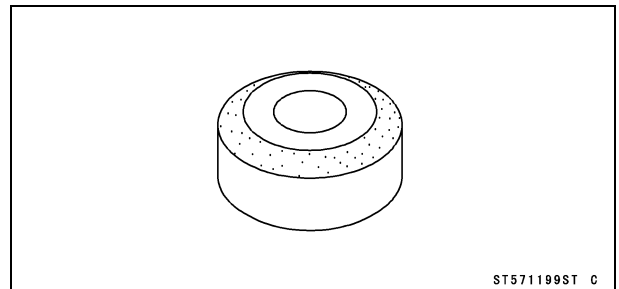

5-12 ENGINE TOP END

Special Tools

Valve Spring Compressor Adapter, $\phi 22$:
57001-1202

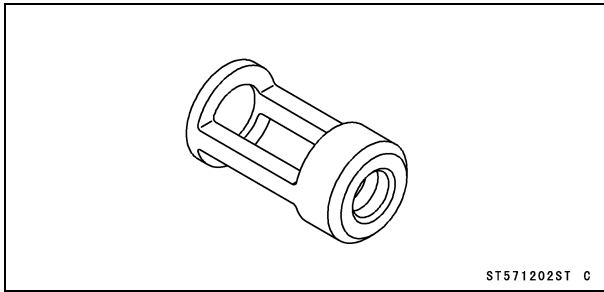

Spark Plug Wrench, Hex 16:
57001-1262

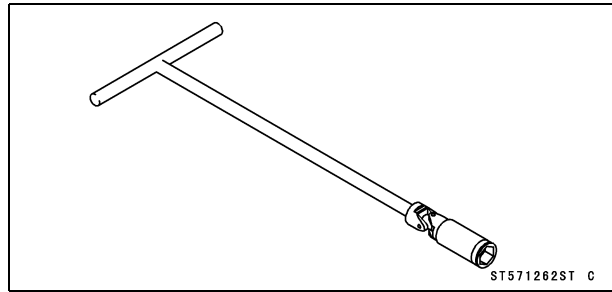

Valve Guide Arbor, $\phi 5$:
57001-1203

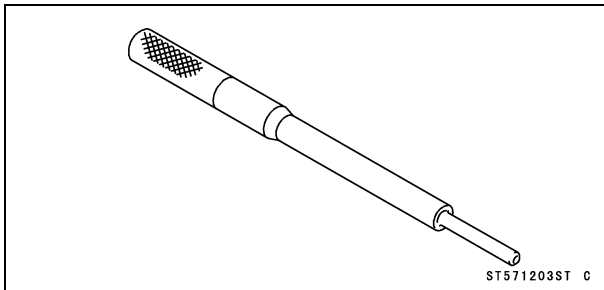

Compression Gauge Adapter, M10 \times 1.0:
57001-1317

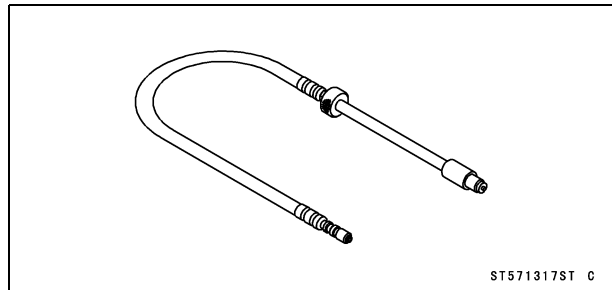

Valve Guide Reamer, $\phi 5$:
57001-1204

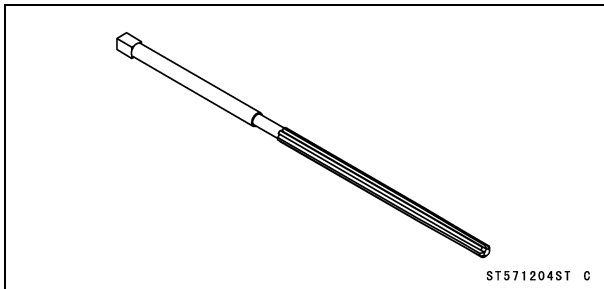

Piston Ring Compressor Belt, $\phi 80 \sim \phi 91$:
57001-1320

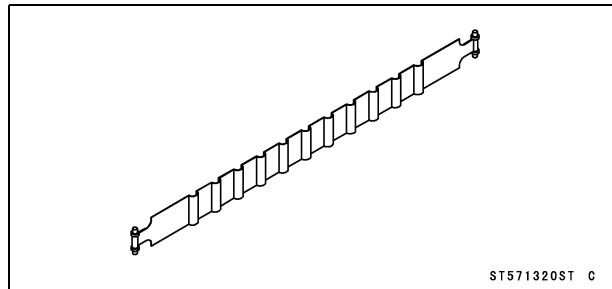

Valve Seat Cutter Holder, $\phi 5$:
57001-1208

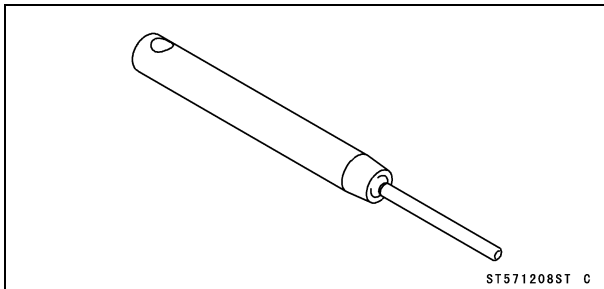

Valve Seat Cutter, 60° - $\phi 33$:
57001-1334

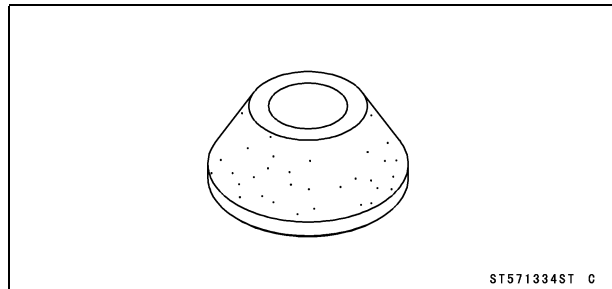

Special Tools

NOTE

○The following valve seat cutters can be used instead of the above tools.

Exhaust Valve Seat:

Valve Seat Cutter, 45° - ϕ 32: 57001-1115

(instead of Valve Seat Cutter: 45° - ϕ 30: 57001-1187)

Valve Seat Cutter, 32° - ϕ 30: 57001-1120

(instead of Valve Seat Cutter: 32° - ϕ 28: 57001-1119)

Valve Seat Cutter, 60° - ϕ 33: 57001-1334

(instead of Valve Seat Cutter: 60° - ϕ 30: 57001-1123)

Inlet Valve Seat:

Valve Seat Cutter, 45° - ϕ 35: 57001-1116

(instead of Valve Seat Cutter: 45° - ϕ 32: 57001-1115)

Valve Seat Cutter, 32° - ϕ 35: 57001-1121

(instead of Valve Seat Cutter: 32° - ϕ 33: 57001-1199)

Valve Seat Cutter, 55° - ϕ 35: 57001-1247

(instead of Valve Seat Cutter: 60° - ϕ 33: 57001-1334)

5-14 ENGINE TOP END

Clean Air System

Air Suction Valve Removal

- Remove:
 - Cylinder Head Covers (see Cylinder Head Cover Removal)
 - Air Suction Valves [A]

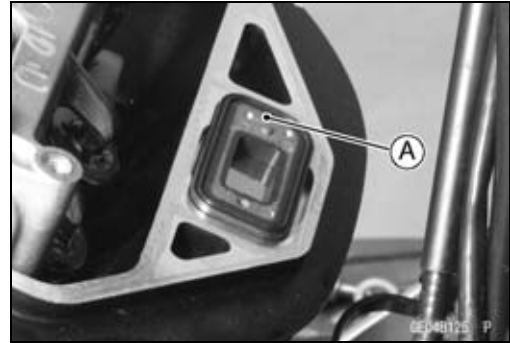

Air Suction Valve Installation

- Install each air suction valve so that stopper side [A] of the reed faces downward.

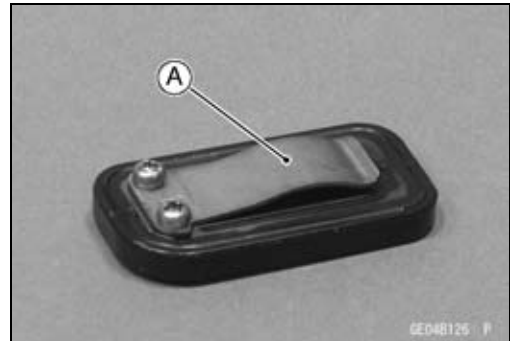

Air Suction Valve Inspection

- Remove the air suction valve (see Air Suction Valve Removal).
- Visually inspect the reeds for cracks, folds, warps, heat damage or other damage.
- ★ If there is any doubt as to the condition of the reeds [A], replace the air suction valve as an assembly.
- Check the reed contact areas [B] of the valve holder for grooves, scratches, any signs of separation from the holder or heat damage.

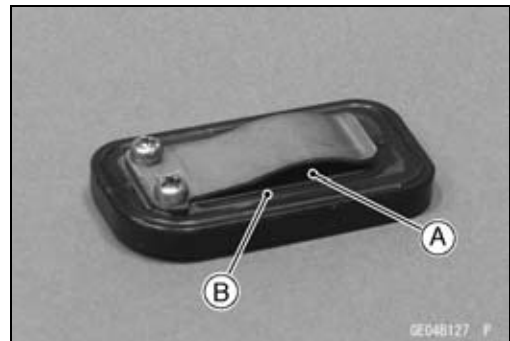

Air Switching Valve Removal

- Remove the fuel tank (see Fuel Tank Removal in the Fuel System (DFI) chapter).
- Disconnect the air switching valve connector [A] and hoses [B].
- Remove the air switching valve [C].

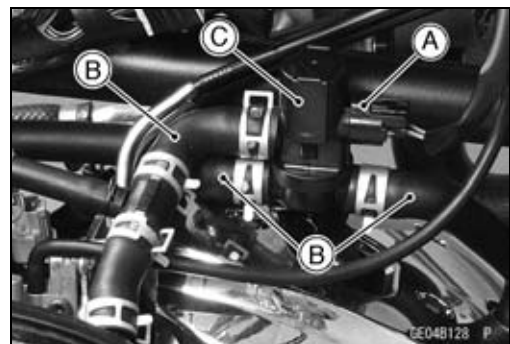

Air Switching Valve Installation

- Route the hoses correctly (see Cable, Wire, and Hose Routing section in the Appendix chapter).

Air Switching Valve Operation Test

- Refer to the Air Suction System Damage Inspection in the Periodic Maintenance chapter.

Air Switching Valve Unit Test

- Refer to the Air Switching Valve Unit Test in the Electrical System chapter.

Clean Air System

Clean Air System Hose Inspection

- Be certain that all the hoses are routed without being flattened or kinked, and are connected correctly to the air cleaner housing, air switching valve, and fittings on the cylinder head covers.
- ★ If they are not, correct them. Replace them if they are damaged.

5-16 ENGINE TOP END

Cylinder Head Covers

Cylinder Head Cover Removal

- Remove:
 - Seat (see Seat Removal in the Frame chapter)
 - Fuel Tank (see Fuel Tank Removal in the Fuel System (DFI) chapter)
- Slide [A] the air switching valve [B] forward to clear the clamp.
- Remove:
 - Bolt [A]
 - Clamp [B]
- Remove the cylinder head outer cover bolts [A].
- Lift up the cylinder head outer cover [A], and while turn the it clockwise, remove it.
- Remove:
 - Dampers [A]
 - Cylinder Head Cover Bolts [B] and Washers
 - Cylinder Head Cover [C]
 - Cylinder Head Cover Gasket

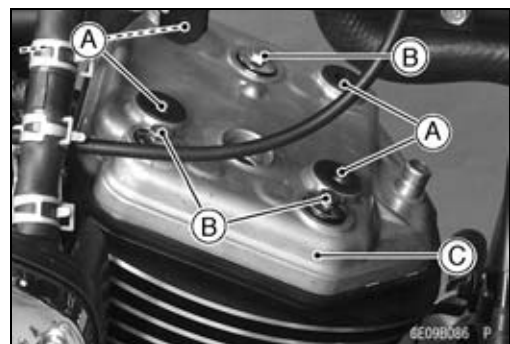
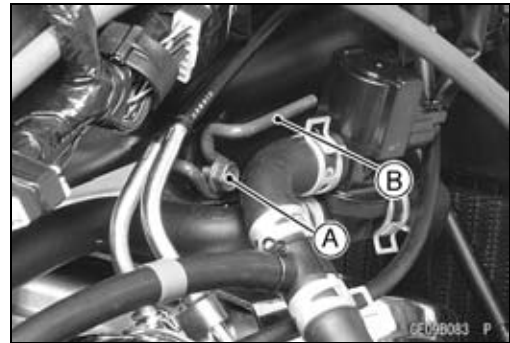
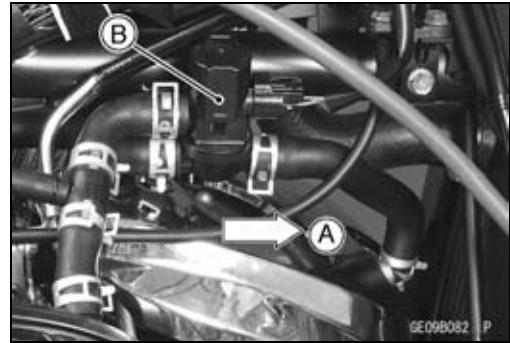

Cylinder Head Covers

- Move the obstruct parts between the cylinder head cover and frame for the cylinder head removal, if necessary. Then lift the cover upward, make sure the spark plug pipe [A] stays in the cylinder head. If the pipe comes up with the cover, reinstall it in the original position.

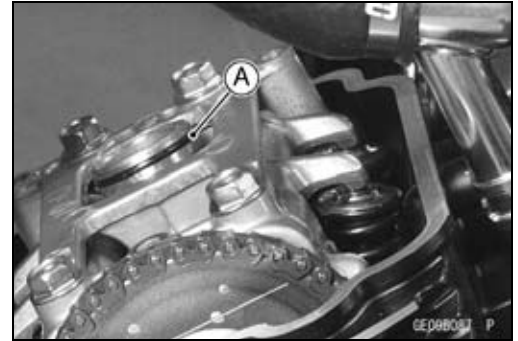

Cylinder Head Cover Installation

- If the plug pipe [A] was removed, install it, and apply grease to the O-ring [B].
- Install:
 - Pin [C]
 - Air Suction Valve [D] (see Air Suction Valve Installation)
 - Head Cover Gasket [E]
- For other than US, CA and CAL models (VN900C9 ~), be sure that the dampers [A] are in positions on the cylinder head cover [B].
 - Front [C]
 - Rear [D]

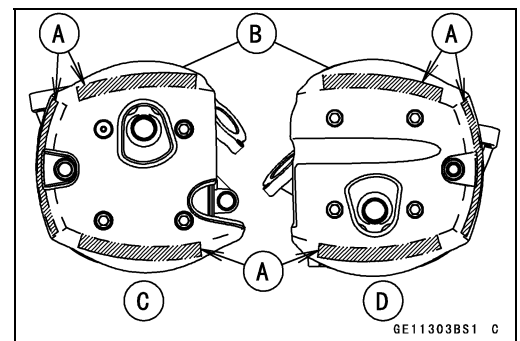
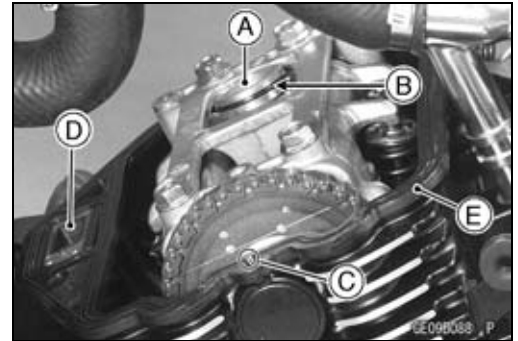

- Install the washer with the metal side [A] faces upward.
- Tighten:
 - Torque - Cylinder Head Cover Bolts: 12 N·m (1.2 kgf·m, 106 in·lb)**

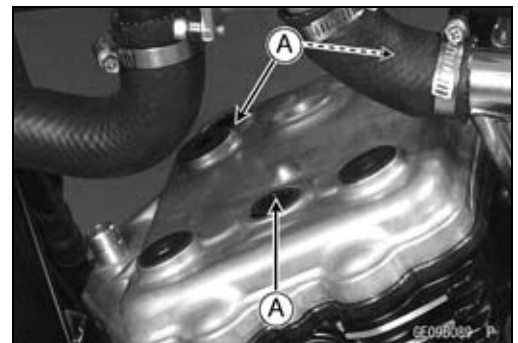

- Install:
 - Dampers
 - Cylinder Head Outer Cover
- Tighten:
 - Torque - Cylinder Head Outer Cover Bolts: 9.8 N·m (1.0 kgf·m, 87 in·lb)**
- Install the removed parts (see appropriate chapters).

5-18 ENGINE TOP END

Camshaft Chain Tensioners

Camshaft Chain Tensioner Removal

- Remove:
 - Engine (see Engine Removal in the Engine Removal/Installation chapter)
 - Camshaft (see Camshaft Removal)
 - Cylinder Head (see Cylinder Head Removal)
- Remove the camshaft chain tensioner body from the cylinder.

Camshaft Chain Tensioner Installation

- Refer to the Cylinder Head Installation and Camshaft Installation.

Camshafts, Camshaft Chains

Camshaft Removal

- Remove:
 - Cylinder Head Cover (see Cylinder Head Cover Removal)
 - Ignition Coil Cover (For Front Cylinder) (see Ignition Coil Removal in the Electrical System chapter)
 - Tensioner Cap Bolt [A], Washer [B] and Spring

NOTICE

Do not turn over the crankshaft while the tensioner cap bolt is removed. The tensioner body is loose from the cylinder while the cap bolt is removed. Turning the crankshaft could damage the tensioner body and/or cylinder, and also the valves because upsetting the camshaft chain timing.

- Release the stopper [A] and push the push rod [B] into the tensioner body [C].
 - Cylinder [D]
 - Camshaft Chain Guide [E]

NOTE

- Temporary, install the tensioner cap bolt [A] only to prevent the tensioner body from falling into the crankcase.

- Remove:
 - Camshaft Cap Bolts [A] (gradually and evenly)
 - Camshaft Cap [B]
- Disengage the camshaft chain [C] from the camshaft sprocket [D], and remove the camshaft.
- Stuff a clean cloth into the chain tunnel to keep any parts from dropping into the crankcase.

NOTICE

The crankshaft may be turned while the camshaft is removed. Always pull the chain taut while turning the crankshaft. This avoids kinking the chain on the lower (crankshaft) sprocket. A kinked chain could damage both the chain and the sprocket.

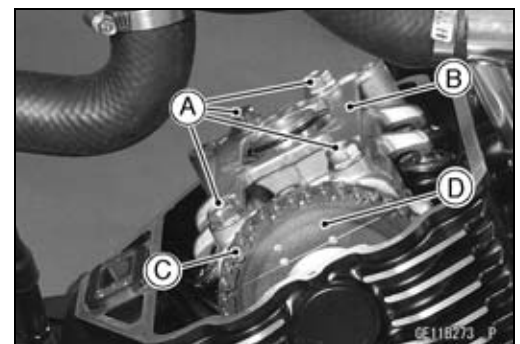
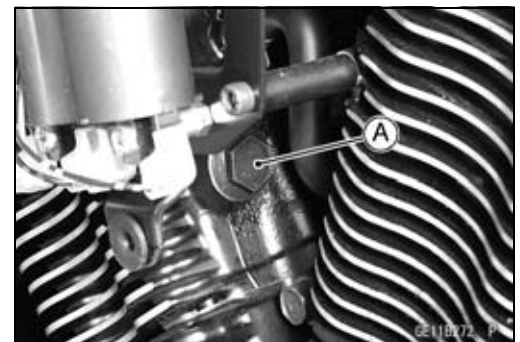
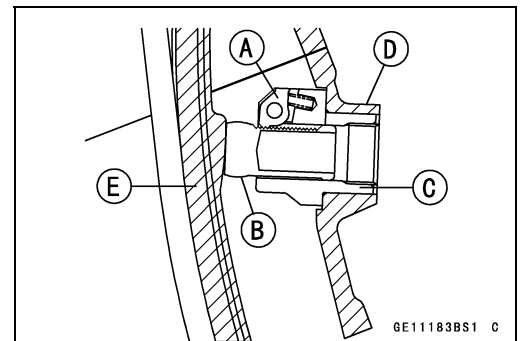
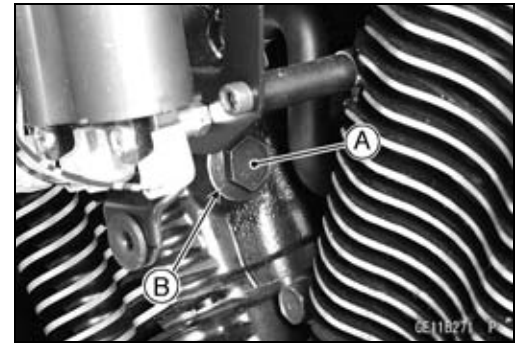

5-20 ENGINE TOP END

Camshafts, Camshaft Chains

Camshaft Installation

- Apply molybdenum disulfide oil solution to all cam parts and journals.

NOTE

- The front and rear camshafts are different. The rear camshaft [A] has a groove [B].

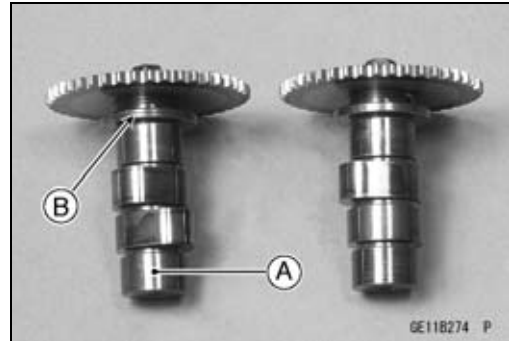

- Remove:
 - Alternator Outer Cover (see Alternator Outer Cover Removal in the Electrical System chapter)
 - Bolts [A]
 - Timing Inspection Plate [B]

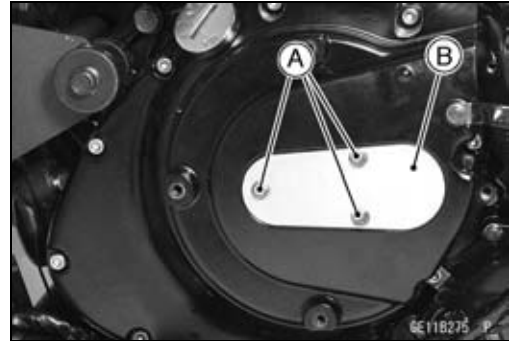

- Set the front piston at TDC.
 - Align the front piston TDC mark [A] and timing mark [B] by turning the alternator rotor bolt counterclockwise [C] (left side view).

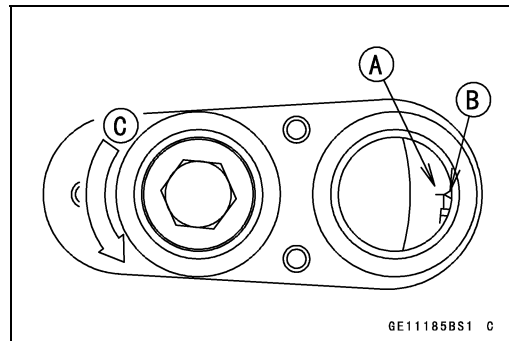

- Engage the camshaft chain [A] with the camshaft sprocket [B].
 - Align the timing mark line [C] on the camshaft sprocket with the cylinder head upper surface [D].
- Install the camshaft cap, and tighten the cap bolts [E].
 - Torque - Camshaft Cap Bolts: 25 N·m (2.5 kgf·m, 18 ft·lb)**

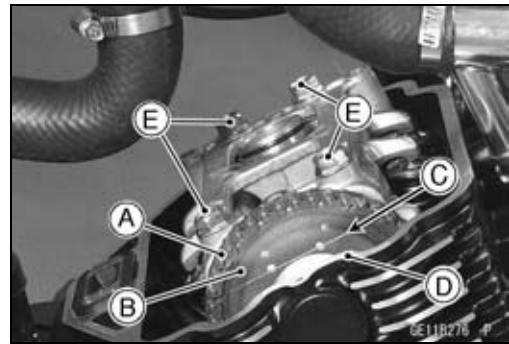

- Install the front camshaft chain tensioner as follows.
 - Remove the cap bolt installed temporarily.
 - Hold the tensioner body and push the push rod [A] until the rod touches to the chain guide [B] lightly.
 - Install the spring, washer [C] and cap bolt [D].
- Tighten:
 - Torque - Camshaft Chain Tensioner Cap Bolt: 20 N·m (2.0 kgf·m, 15 ft·lb)**

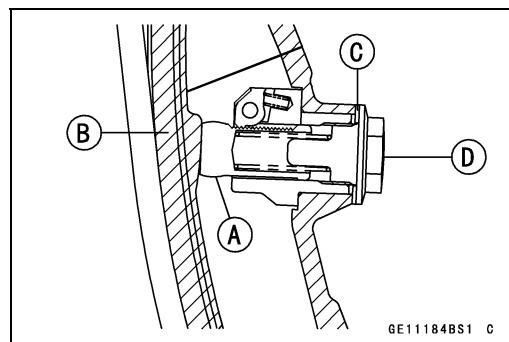

Camshafts, Camshaft Chains

NOTE

○Installing the rear camshaft is the same as for the front camshaft. But noting the following.

- Set the rear piston at TDC.
- Align the rear piston TDC mark [A] and timing mark [B] by turning the crankshaft counterclockwise [C] 305° (left side view).

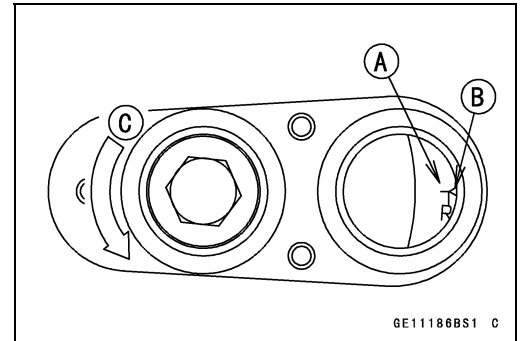

Camshaft, Camshaft Cap Wear Inspection

- Remove the camshaft caps (see Camshaft Removal).
- Cut strips of plastigage to journal width. Place a strip on each journal parallel to the camshaft installed in the correct position.
- Measure each clearance between the camshaft journal and the camshaft cap using plastigage (press gauge).
- Tighten:

Torque - Camshaft Cap Bolts: 25 N·m (2.5 kgf·m, 18 ft·lb)

NOTE

○Do not turn the camshaft when the plastigage is between the journal and camshaft cap.

- Remove the camshaft cap again, and measure the plastigage width [A] to determine the clearance between each journal and the camshaft cap. Measure the maximum plastigage width.

Camshaft Journal, Camshaft Cap Clearance

Standard: 0.028 ~ 0.071 mm (0.0011 ~ 0.0028 in.)

Service Limit: 0.16 mm (0.0063 in.)



- ★ If any clearance exceeds the service limit, measure the diameter of each camshaft journal with a micrometer.

Camshaft Journal Diameter

Standard: 26.950 ~ 26.972 mm (1.0610 ~ 1.0619 in.)

Service Limit: 26.92 mm (1.060 in.)

- ★ If the camshaft journal diameter is less than the service limit, replace the camshaft with a new one and measure the clearance again.
- ★ If the clearance still remains out of the limit, replace the cylinder head and camshaft cap.

NOTICE

The camshaft cap and cylinder head are machined in the assembled state, so they must be replaced as a set.

5-22 ENGINE TOP END

Camshafts, Camshaft Chains

Camshaft Runout Inspection

- Remove the camshaft (see Camshaft Removal).
- Set the camshaft in a camshaft alignment jig or on V blocks.
- Measure runout with a dial gauge at the specified place as shown in the figure.
- ★ If the runout exceeds the service limit, replace the shaft.

Camshaft Runout

- Standard:** TIR 0.02 mm (0.0008 in.) or less
Service Limit: TIR 0.1 mm (0.004 in.)

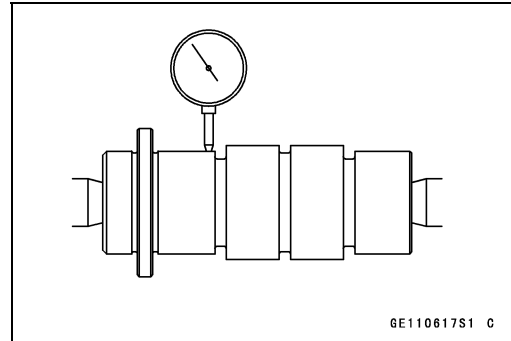

Cam Wear Inspection

- Remove the camshaft (see Camshaft Removal).
- Measure the height [A] of each cam with a micrometer.
- ★ If the cams are worn down past the service limit, replace the camshaft.

Cam Height

- Standard:**
Exhaust 35.030 ~ 35.144 mm (1.3791 ~ 1.3836 in.)
Inlet 35.302 ~ 35.416 mm (1.3898 ~ 1.3943 in.)
- Service Limit:**
Exhaust 34.93 mm (1.375 in.)
Inlet 35.20 mm (1.386 in.)

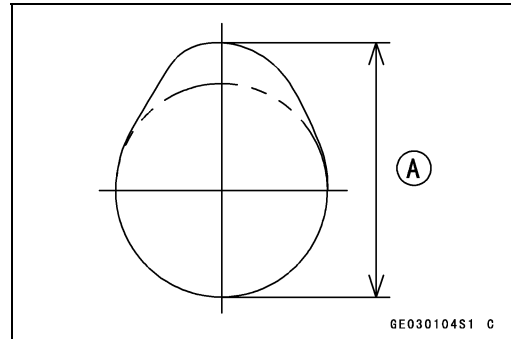

Camshaft Chain Removal

Front Camshaft Chain

- Remove:
 - Front Camshaft (see Camshaft Removal)
 - Alternator Rotor (see Alternator Rotor Removal in the Electrical System chapter)
 - Bolts [A]
 - Rear Chain Guide [B]
 - Bolt [C] and Washer [D]
 - Front Chain Guide [E]
- Disengage the camshaft chain [F] from the crankshaft sprocket and then remove the chain.

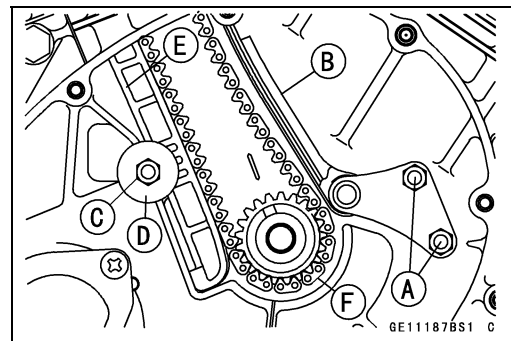

Rear Camshaft Chain

- Remove:
 - Rear Camshaft (see Camshaft Removal)
 - Primary Gear (see Primary Gear Removal in the Crankshaft/Transmission chapter)
 - Clutch (see Clutch Removal in the Clutch chapter)
 - Bolts [A]
 - Rear Chain Guide [B]
 - Front Chain Guide [C]
- Disengage the camshaft chain [D] from the crankshaft sprocket and then remove the chain.

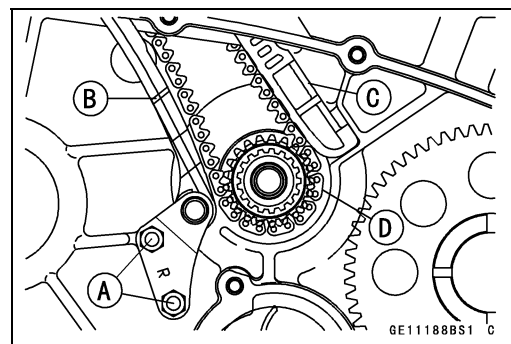

Camshafts, Camshaft Chains

Camshaft and Sprocket Assembly

- Clean the sprocket bolt [A] and threads of the camshaft.
- Be sure to install the pin [B].
- Apply a non-permanent locking agent to the threads of the camshaft sprocket bolt, and tighten it. The sprockets are identical.

Torque - Camshaft Sprocket Bolt: 49 N·m (5.0 kgf·m, 36 ft·lb)

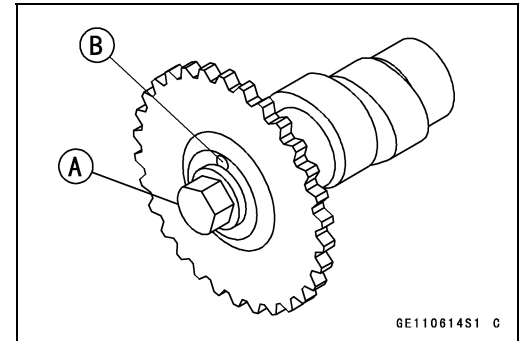

5-24 ENGINE TOP END

Rocker Shafts, Rocker Arms

Rocker Shaft, Rocker Arm Removal

- Remove:
 - Cylinder Head Cover (see Cylinder Head Cover Removal)
 - Camshaft Cap (see Camshaft Removal)
 - Rocker Shafts [A]
 - Rocker Arms [B] and Springs [C]

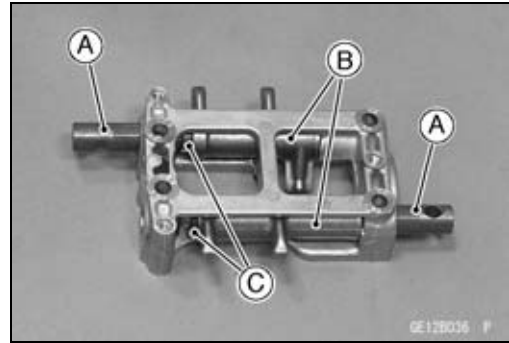

Rocker Shaft, Rocker Arm Installation

- Apply molybdenum disulfide grease to the rocker shaft.
- Insert the rocker shaft into the camshaft cap and rocker arm so that the notch side [A] faces to the spring end.
- Inlet side spring is red paint marked.
- Align the bolt holes [B] of the camshaft cap and rocker shaft.

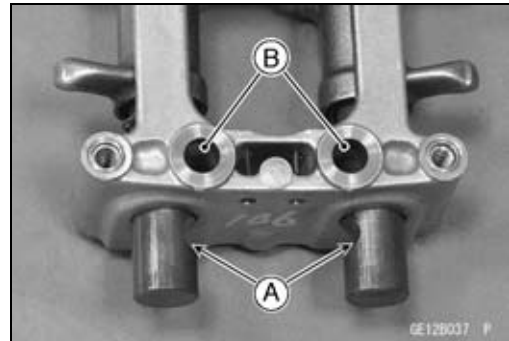

Cylinder Heads

Cylinder Compression Measurement

NOTE

○ Use the battery which is fully charged.

- Warm up the engine thoroughly.
- Stop the engine.
- Remove:
 - Seat (see Seat Removal in the Frame chapter)
 - Fuel Tank (see Fuel Tank Removal in the Fuel System (DFI) chapter)
 - Spark Plugs (see Spark Plug Replacement in the Periodic Maintenance chapter)

Special Tool - Spark Plug Wrench, Hex 16: 57001-1262

- Attach the compression gauge [A] and adapter [B] firmly into the spark plug hole.
- Using the starter motor, turn the engine over with the throttle fully open until the compression gauge stops rising; the compression is the highest reading obtainable.

Special Tools - Compression Gauge, 20 kgf/cm²: 57001-221
Compression Gauge Adapter, M10 × 1.0: 57001-1317

Cylinder Compression

Usable Range: 980 ~ 1 570 kPa (10.0 ~ 16.0 kgf/cm², 142 ~ 228 psi) at 470 r/min (rpm)

- Repeat the measurement for the other cylinders.
- Install the spark plugs and tighten them.

Torque - Spark Plugs: 18 N·m (1.8 kgf·m, 13 ft·lb)

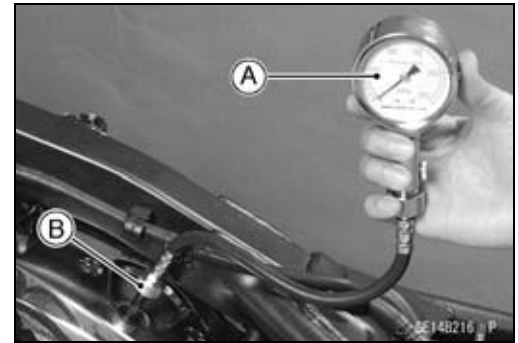

○ The following table should be consulted if the obtainable compression reading is not within the usable range.

| Problem | Diagnosis | Remedy (Action) |
|--|---|--|
| Cylinder compression is higher than usable range | Carbon accumulation on piston and in combustion chamber possibly due to damaged valve stem oil seal and/or damaged piston oil rings (This may be indicated by white exhaust smoke). | Remove the carbon deposits and replace damaged parts if necessary. |
| | Incorrect cylinder head gasket thickness. | Replace the gasket with a standard part. |
| Cylinder compression is lower than usable range | Gas leakage around cylinder head | Replace damaged gasket and check cylinder head warp. |
| | Bad condition of valve seating | Repair if necessary. |
| | Incorrect valve clearance | Adjust the valve clearance. |
| | Incorrect piston/cylinder clearance | Replace the piston and/or cylinder. |
| | Piston seizure | Inspect the cylinder and replace/repair the cylinder and/or piston as necessary. |
| | Bad condition of piston ring and/or piston ring grooves | Replace the piston and/or the piston rings. |

5-26 ENGINE TOP END

Cylinder Heads

Cylinder Head Removal

- Remove:
 - Engine (see Engine Removal in the Engine Removal/Installation chapter)
 - Camshaft (see Camshaft Removal)
- Remove the cylinder head nuts following sequence [1 ~ 6].
- Remove the cylinder head.

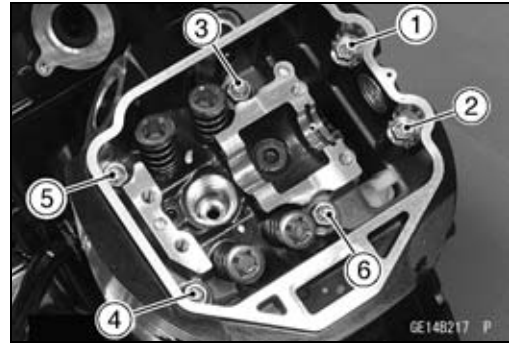

Cylinder Head Installation

NOTE

- The camshaft cap is machined with the cylinder head, so if a new cylinder head is installed, use the cap that is supplied with the new head.
- The front cylinder head has a breather pipe fitting. Be careful not to mix up the front and rear cylinder heads.
- Release the stopper and push the push rod into the tensioner body [A], and tighten the cap bolt only temporarily.
- Replace the cylinder head gasket with a new one.
- Install:
 - Oil Pipe [B]
 - Chain Guide (White) [C]
 - Dowel Pins
 - Cylinder Head Gasket [D]

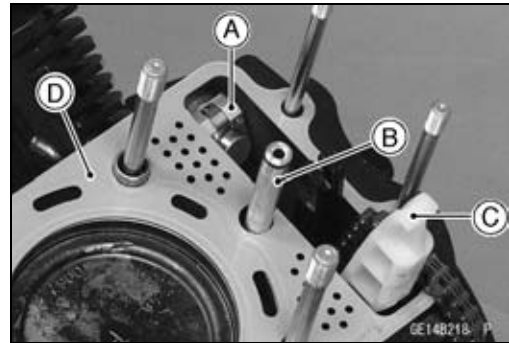

- Apply molybdenum disulfide oil solution to both sides of the cylinder head nut washers and the thread of head nuts.
- Temporarily tighten the cylinder head nuts (M10) following the tightening sequence [1 ~ 4].

Torque - Cylinder Head Nuts (M10) (First): 20 N·m (2.0 kgf·m, 15 ft·lb)

- Tighten the cylinder head nuts following the tightening sequence [1 ~ 6].

Torque - Cylinder Head Nuts (M10) (Final): 49 N·m (5.0 kgf·m, 36 ft·lb)

Cylinder Head Nuts (M8): 25 N·m (2.5 kgf·m, 18 ft·lb)

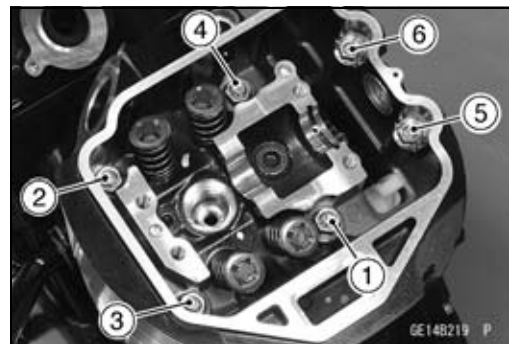

Cylinder Head Warp Inspection

- Lay a straightedge across the lower surface of the cylinder head at several positions.
- Use a thickness gauge [A] to measure the space between the straightedge [B] and the head.

Cylinder Head Warp

Standard: ---

Service Limit: 0.05 mm (0.002 in.)

- ★ If the cylinder head is warped more than the service limit, replace it.
- ★ If the cylinder head is warped less than the service limit, repair the head by rubbing the lower surface on emery paper secured to a surface plate (first No. 200, then No. 400).

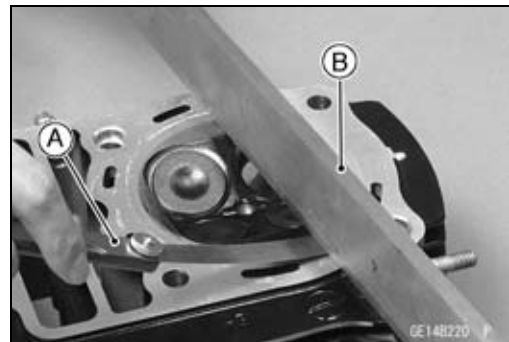

Valves

Valve Clearance Inspection

- Refer to the Valve Clearance Inspection in the Periodic Maintenance chapter.

Valve Clearance Adjustment

- Refer to the Valve Clearance Adjustment in the Periodic Maintenance chapter.

Valve Removal

- Remove the cylinder head (see Cylinder Head Removal).
- Swing open the rocker arm, and then remove the shims.
- Mark and record the shim locations so that the shims can be installed in their original positions.
- Using the valve spring compressor assembly, remove the valve.

Special Tools - Valve Spring Compressor Assembly [A]:
57001-241

Valve Spring Compressor Adapter, $\phi 22$ [B]:
57001-1202

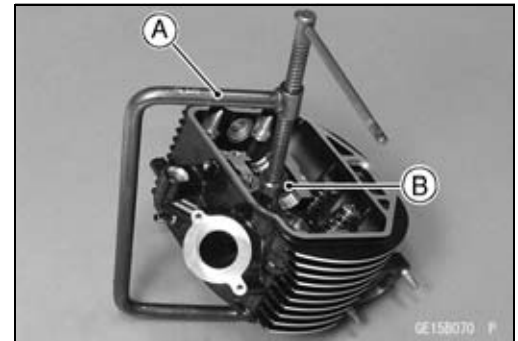

Valve Installation

- Replace the oil seal with a new one.
- Apply a thin coat of molybdenum disulfide grease to the valve stem before valve installation.
- Install the springs so that the closed coil end faces downwards or painted side upwards.

Valve Stem [A]

Oil Seal [B]

Spring Seat [C]

Valve Spring [D]

Retainer [E]

Split Keepers [F]

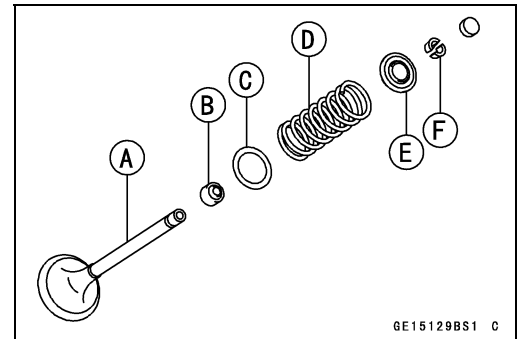

Valve Guide Removal

- Remove:
 - Valve (see Valve Removal)
 - Oil Seal
 - Spring Seat
- Heat the area around the valve guide to 120 ~ 150°C (248 ~ 302°F), and hammer lightly on the valve guide arbor [A] to remove the guide from the top of the head.

NOTICE

Do not heat the cylinder head with a torch. This will warp the cylinder head. Soak the cylinder head in oil and heat the oil.

Special Tool - Valve Guide Arbor, $\phi 5$: 57001-1203

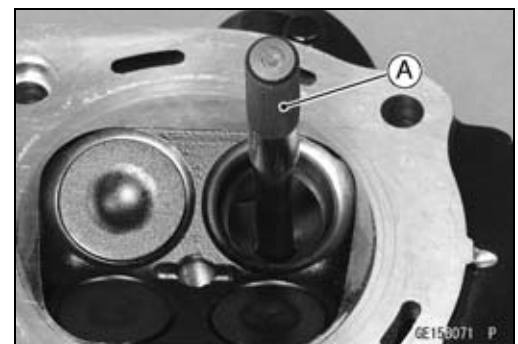

5-28 ENGINE TOP END

Valves

Valve Guide Installation

- Apply oil to the valve guide outer surface before installation.
- Heat the area around the valve guide hole to about 120 ~ 150°C (248 ~ 302°F).
- Drive the valve guide in from the top of the head using the valve guide arbor [A]. The flange stops the guide from going in too far.

Special Tool - Valve Guide Arbor, ϕ 5: 57001-1203

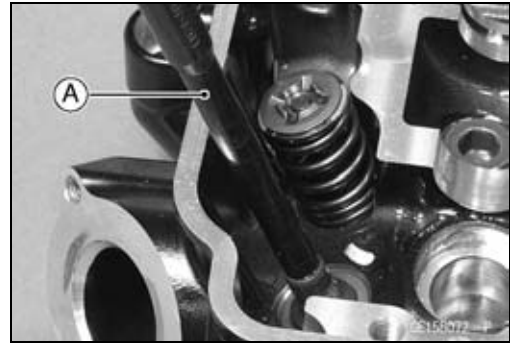

- Wait until the cylinder head cools down and then ream the valve guide with the valve guide reamer [A] even if the old guide is reused.
- Turn the reamer in a clockwise direction until the reamer turns freely in the guide. Never turn the reamer counter-clockwise or it will be dulled.
- Once the guides are reamed they must be cleaned thoroughly.

Special Tool - Valve Guide Reamer, ϕ 5: 57001-1204

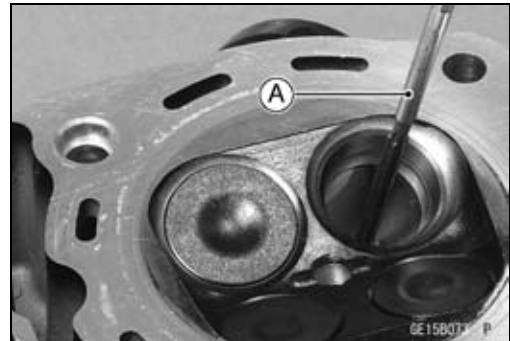

Valve-to-Guide Clearance Measurement (Wobble Method)

If a small bore gauge is not available, inspect the valve guide wear by measuring the valve to valve guide clearance with the wobble method as indicated below.

- Insert a new valve [A] into the guide [B] and set a dial gauge against the stem perpendicular to it as close as possible to the cylinder head mating surface.
- Move the stem back and forth [C] to measure valve/valve guide clearance.
- Repeat the measurement in a direction at a right angle to the first.
- ★ If the reading exceeds the service limit, replace the guide.

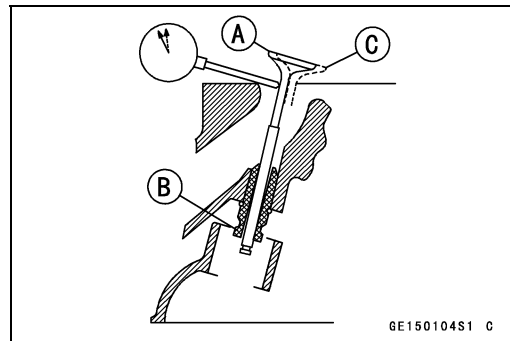

NOTE

- The reading is not actual valve/valve guide clearance because the measuring point is above the guide.

Valve/Valve Guide Clearance (Wobble Method)

Standard:

| | |
|---------|--------------------------------------|
| Exhaust | 0.09 ~ 0.17 mm (0.0035 ~ 0.0067 in.) |
| Inlet | 0.03 ~ 0.11 mm (0.0012 ~ 0.0043 in.) |

Service Limit:

| | |
|---------|---------------------|
| Exhaust | 0.38 mm (0.015 in.) |
| Inlet | 0.32 mm (0.013 in.) |

Valves

Valve Seat Inspection

- Remove the valve (see Valve Removal).
- Check the valve seating surface [A] between the valve [B] and valve seat [C].
- Measure the outside diameter [D] of the seating pattern on the valve seat.
- ★ If the outside diameter is too large or too small, repair the seat (see Valve Seat Repair).

Valve Seating Surface Outside Diameter

Standard:

| | |
|---------|------------------------------------|
| Exhaust | 26.9 ~ 27.1 mm (1.059 ~ 1.067 in.) |
| Inlet | 30.9 ~ 31.1 mm (1.216 ~ 1.224 in.) |

- Measure the seat width [E] of the portion where there is no build-up carbon (white portion) of the valve seat with a vernier caliper.

Good [F]

- ★ If the width is too wide [G], too narrow [H] or uneven [J], repair the seat (see Valve Seat Repair).

Valve Seating Surface Width

Standard:

| | |
|---------|--------------------------------|
| Exhaust | 0.5 ~ 1.0 mm (0.02 ~ 0.04 in.) |
| Inlet | 0.5 ~ 1.0 mm (0.02 ~ 0.04 in.) |

Valve Seat Repair

- Repair the valve seat with the valve seat cutters [A].

Special Tools -

Valve Seat Cutter Holder Bar [B]: 57001-1128

Valve Seat Cutter Holder, $\phi 5$ [C]: 57001-1208

[For Exhaust Valve Seat]

Valve Seat Cutter, 45° - $\phi 30$: 57001-1187

or Valve Seat Cutter, 45° - $\phi 32$: 57001-1115

Valve Seat Cutter, 32° - $\phi 28$: 57001-1119

or Valve Seat Cutter, 32° - $\phi 30$: 57001-1120

Valve Seat Cutter, 60° - $\phi 30$: 57001-1123

or Valve Seat Cutter, 60° - $\phi 33$: 57001-1334

[For Inlet Valve Seat]

Valve Seat Cutter, 45° - $\phi 32$: 57001-1115

or Valve Seat Cutter, 45° - $\phi 35$: 57001-1116

Valve Seat Cutter, 32° - $\phi 33$: 57001-1199

or Valve Seat Cutter, 32° - $\phi 35$: 57001-1121

Valve Seat Cutter, 60° - $\phi 33$: 57001-1334

or Valve Seat Cutter, 55° - $\phi 35$: 57001-1247

- ★ If the manufacturer's instructions are not available, use the following procedure.

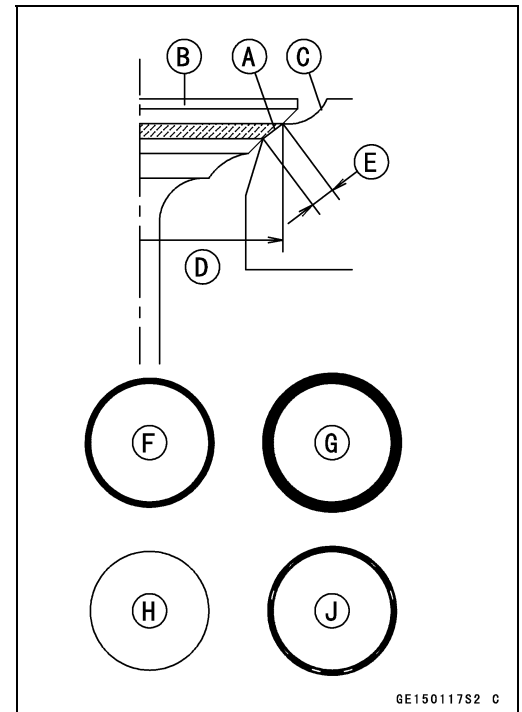

GE150117S2 C

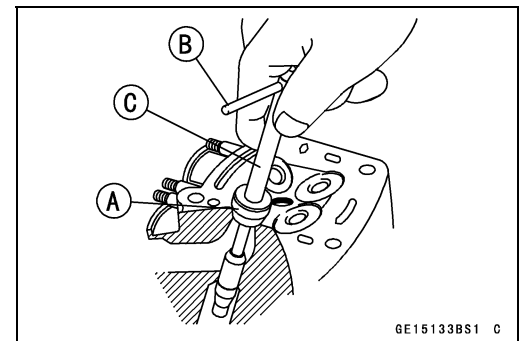

GE15133BS1 C

5-30 ENGINE TOP END

Valves

Seat Cutter Operation Care

1. This valve seat cutter is developed to grind the valve for repair. Therefore the cutter must not be used for other purposes than seat repair.
2. Do not drop or shock the valve seat cutter, or the diamond particles may fall off.
3. Do not fail to apply engine oil to the valve seat cutter before grinding the seat surface. Also wash off ground particles sticking to the cutter with washing oil.

NOTE

○Do not use a wire brush to remove the metal particles from the cutter. It will take off the diamond particles.

4. Setting the valve seat cutter holder in position, operate the cutter in one hand. Do not apply too much force to the diamond portion.

NOTE

○Prior to grinding, apply engine oil to the cutter and during the operation, wash off any ground particles sticking to the cutter with washing oil.

5. After use, wash it with washing oil and apply thin layer of engine oil before storing.

Marks Stamped on the Cutter

The marks stamped on the back of the cutter [A] represent the following.

- 60° Cutter angle [B]
- 37.5φ Outer diameter of cutter [C]

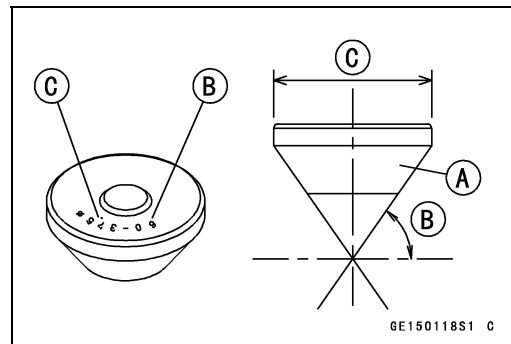

Operating Procedures

- Clean the seat area carefully.
- Coat the seat with machinist's dye.
- Fit a 45° cutter into the holder and slide it into the valve guide.
- Press down lightly on the handle and turn it right or left. Grind the seating surface only until it is smooth.

NOTICE

Do not grind the seat too much. Overgrinding will reduce valve clearance by sinking the valve into the head. If the valve sinks too far into the head, it will be impossible to adjust the clearance, and the cylinder head must be replaced.

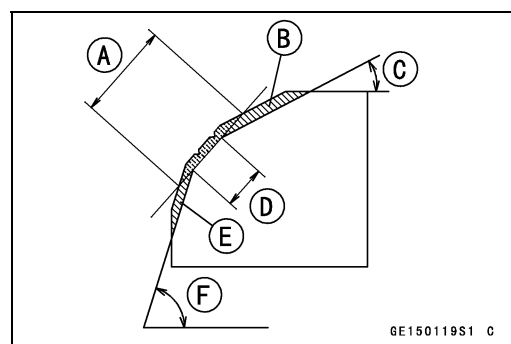

- Widened Width [A] of engagement by machining with 45° cutter
- Ground Volume [B] by 32° cutter
- 32° [C]
- Correct Width [D]
- Ground Volume [E] by 60° cutter
- 60° [F]

Valves

- Measure the outside diameter of the seating surface with a vernier caliper.
- ★ If the outside diameter of the seating surface is too small, repeat the 45° grind [A] until the diameter is within the specified range.

Original Seating Surface [B]

NOTE

- Remove all pittings or flaws from 45° ground surface.
- After grinding with 45° cutter, apply thin coat of machinist's dye to seating surface. This makes seating surface distinct and 32° and 60° grinding operation easier.
- When the valve guide is replaced, be sure to grind with 45° cutter for centering and good contact.

- ★ If the outside diameter of the seating surface is too large, make the 32° grind described below.
- ★ If the outside diameter [A] of the seating surface is within the specified range, measure the seat width as described below.
- Grind the seat at a 32° angle [B] until the seat outside diameter is within the specified range.
- To make the 32° grind, fit a 32° cutter into the holder, and slide it into the valve guide.
- Turn the holder one turn at a time while pressing down very lightly. Check the seat after each turn.

NOTICE

The 32° cutter removes material very quickly. Check the seat outside diameter frequently to prevent overgrinding.

- After making the 32° grind, return to the seat outside diameter measurement step above.
 - To measure the seat width, use a vernier caliper to measure the width of the 45° angle portion of the seat at several places around the seat.
 - ★ If the seat width is too narrow, repeat the 45° grind until the seat is slightly too wide, and then return to the seat outside diameter measurement step above.
 - ★ If the seat width is too wide, make the 60° [A] grind described below.
 - ★ If the seat width is within the specified range, lap the valve to the seat as described below.
 - Grind the seat at a 60° angle until the seat width is within the specified range.
 - To make the 60° grind, fit 60° cutter into the holder, and slide it into the valve guide.
 - Turn the holder, while pressing down lightly.
 - After making the 60° grind, return to the seat width measurement step above.
- Correct Width [B]

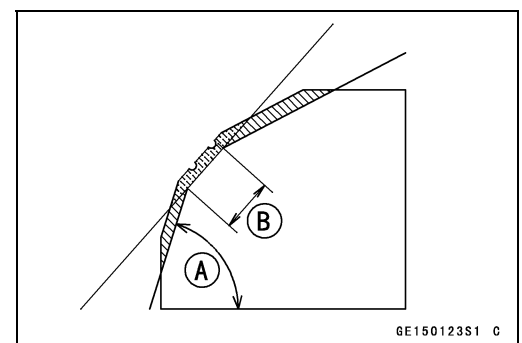
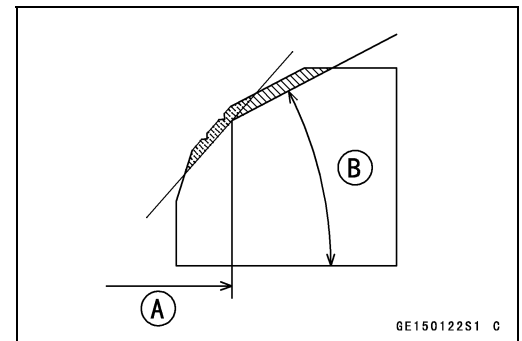
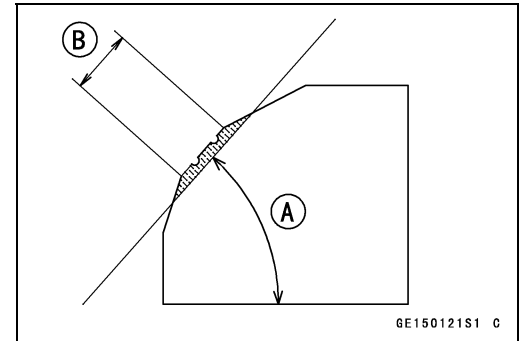

5-32 ENGINE TOP END

Valves

- Lap the valve to the seat, once the seat width and outside diameter are within the ranges specified above.
- Put a little coarse grinding compound on the face of the valve in a number of places around the valve head.
- Spin the valve against the seat until the grinding compound produces a smooth, matched surface on both the seat and the valve.
- Repeat the process with a fine grinding compound.
 - Lapper [A]
 - Valve Seat [B]
 - Valve [C]
- The seating area should be marked about in the middle of the valve face.
- ★ If the seat area is not in the right place on the valve, check to be sure the valve is the correct part. If it is, it may have been refaced too much; replace it.
- Be sure to remove all grinding compound before assembly.
- When the engine is assembled, be sure to adjust the valve clearance (see Valve Clearance Adjustment in the Periodic Maintenance chapter).

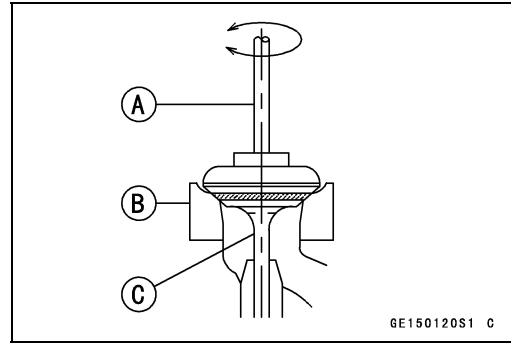

Valves

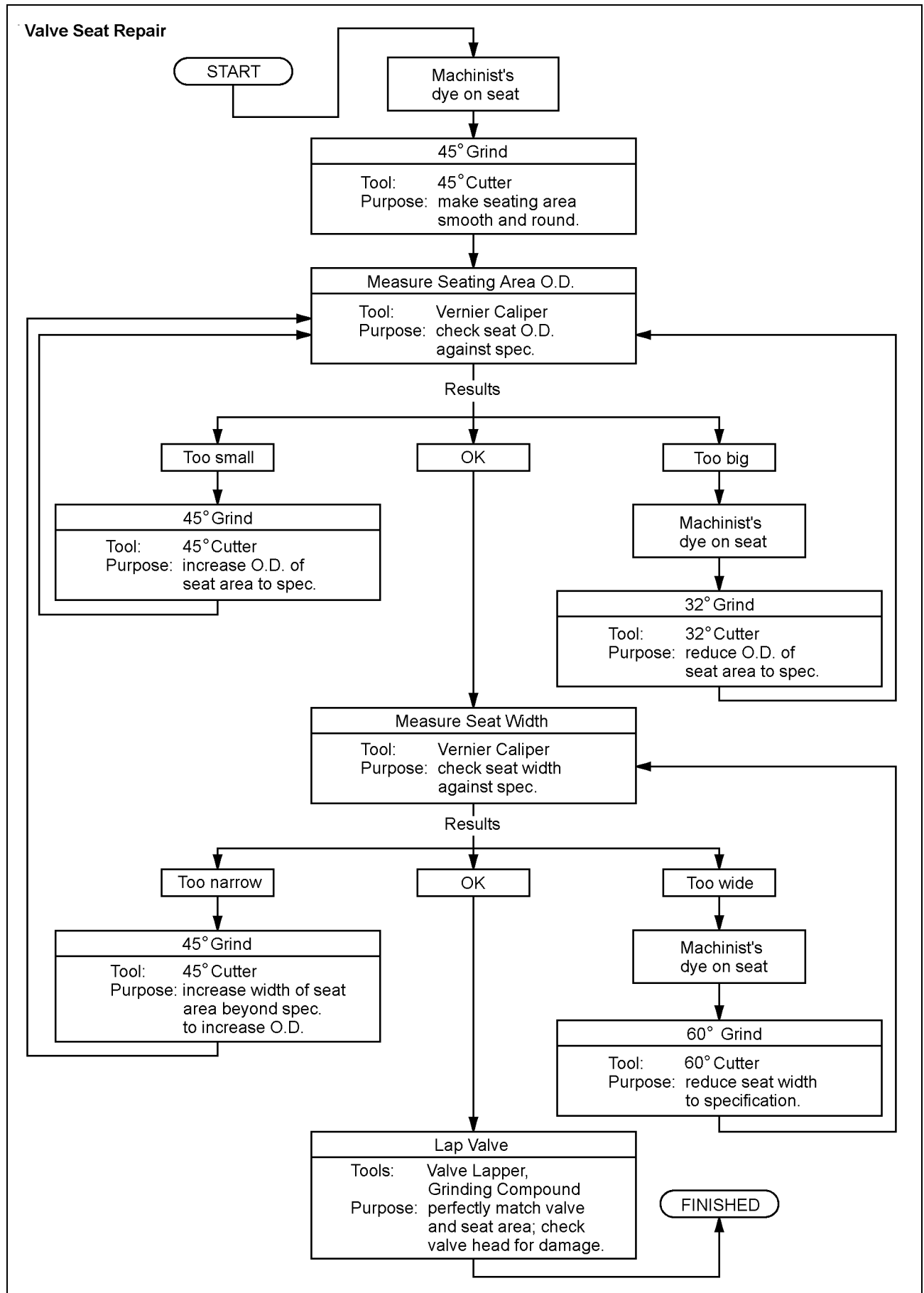

5-34 ENGINE TOP END

Cylinders, Pistons

Cylinder Removal

- Remove:
 - Engine (see Engine Removal in the Engine Removal/Installation chapter)
 - Cylinder Head (see Cylinder Head Removal)
- Pull out the front camshaft chain guide [A] and oil pipe [B].
- Tap lightly up the cylinder with a plastic mallet to separate from the crankcase.
- Remove the cylinder base gasket.

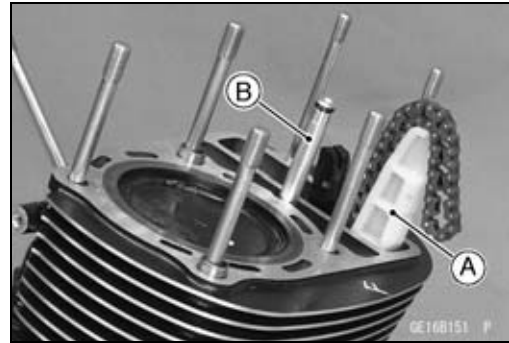

Piston Removal

- Remove the cylinder (see Cylinder Removal).
- Place a piece of clean cloth under the piston and remove the piston pin snap rings [A] from the outside of each piston.



NOTICE

Do not reuse snap rings, as removal weakens and deforms them. They could fall out and score the cylinder wall.

- Using the piston pin puller assembly, remove the piston pin.
 - Special Tool - Piston Pin Puller Assembly [A]: 57001-910**
- Remove the piston.

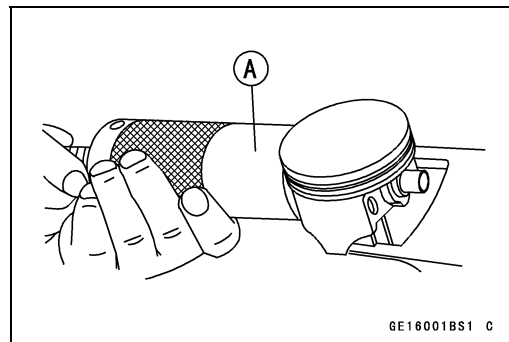

- Carefully spread the ring opening with your thumbs and then push up on the opposite side of the ring [A] to remove it.
- Remove the 3-piece oil ring with your thumbs in the same manner.

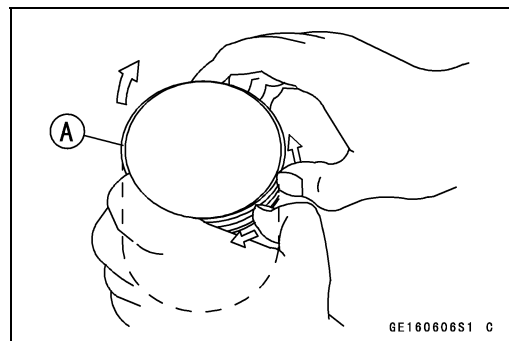

Cylinder, Piston Installation

NOTE

○The oil ring rails have no "top" or "bottom".

- Install the oil ring expander [A] in the bottom piston ring groove so the ends [B] butt together.
- Install the oil ring steel rails, one above the expander and one below it.
- Spread the rail with your thumbs, but only enough to fit the rail over the piston.
- Release the rail into the bottom piston ring groove.

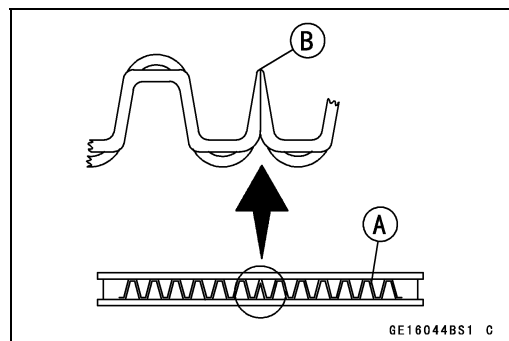

Cylinders, Pistons

- Do not mix up the top ring and second ring.
- Install the top ring [A] so that the "R" mark [B] faces up.
- Install the second ring [C] so that the "RN" mark [D] faces up.

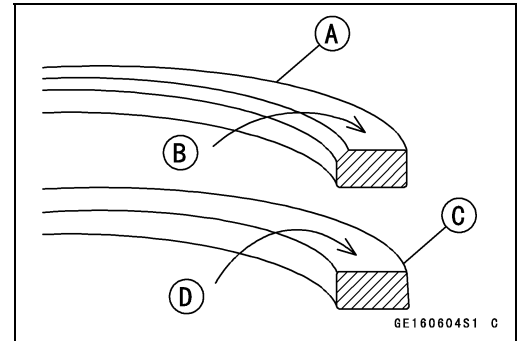

- The piston ring openings must be positioned as shown in the figure. The openings of the oil ring steel rails must be about 30 ~ 45° of angle from the opening of the top ring.

- Top Ring [A]
- Second Ring [B]
- Oil Ring Steel Rails [C]
- Oil Ring Expander [D]
- Dent [E] must be faced toward the exhaust side.
- 30 ~ 45° [F]
- Opening Positions [G]

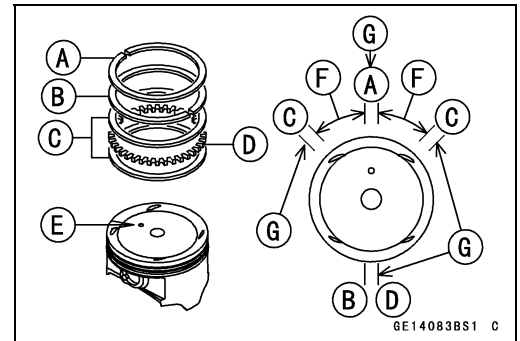

- Face the dent [A] on the front piston [B] toward the front side [C] and the dent [D] on the rear piston [E] toward the rear side [F] as shown in the figure.
- The front and rear pistons are the same, but they should be installed in their original positions.

NOTICE

Incorrect installation of the piston could cause piston seizure and result in severe engine damage.

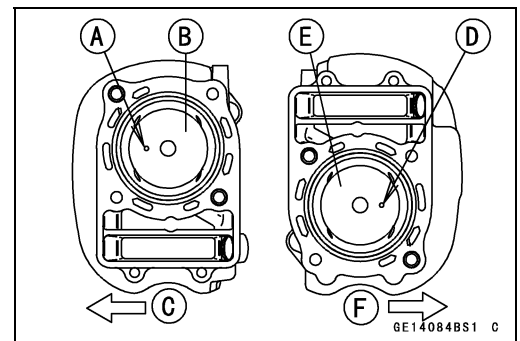

- Fit a new piston pin snap ring into the side of the piston so that the ring opening [A] does not coincide with the slit [B] of the piston pin hole.
- Apply molybdenum disulfide oil solution to the outer surface of the piston pin.
- When installing the piston pin snap ring, compress it only enough to install it and no more.
- Apply molybdenum disulfide oil solution to the cylinder bore.
- Apply molybdenum disulfide oil solution to the front and rear of the piston skirt.

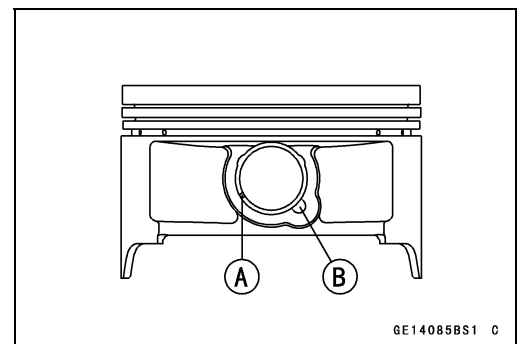

- Install the rear cylinder first, with the rear piston at TDC.
- Using the piston ring compressor assembly [A] with the chamfered side [B] upward, install the cylinder block [C].

Special Tools - Piston Ring Compressor Grip: 57001-1095
Piston Ring Compressor Belt, φ80 ~ φ91: 57001-1320

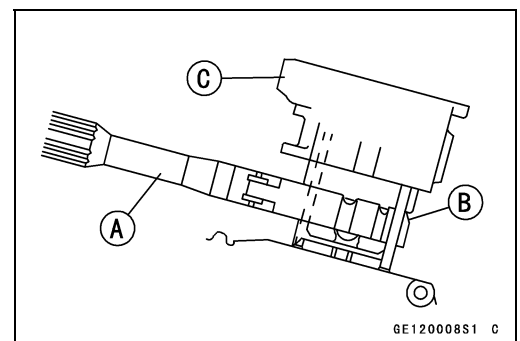

5-36 ENGINE TOP END

Cylinders, Pistons

NOTE

○ If a new piston or cylinder is used, check piston to cylinder clearance (see *Piston/Cylinder Clearance*), and use new piston ring.

- Replace the cylinder base gasket with a new one.
- Be sure to install the dowel pins [A].



- Install the front cylinder in the same way.
- Position the front piston at TDC.

Cylinder Wear Inspection

- Since there is a difference in cylinder wear in different directions, take a side-to-side and a front-to-back measurement at each of the 3 locations (total of 6 measurements) shown in the figure.
- ★ If any of the cylinder inside diameter measurements exceeds the service limit, replace the cylinder.
 - 10 mm (0.39 in.) [A]
 - 60 mm (2.4 in.) [B]
 - 20 mm (0.79 in.) [C]

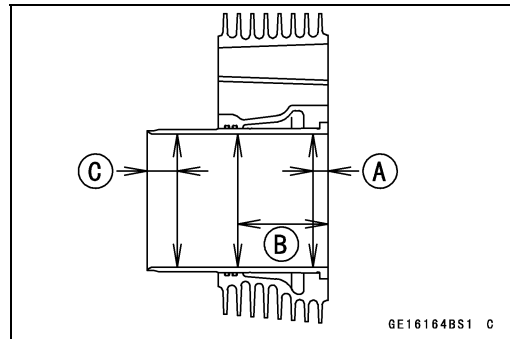

Cylinder Inside Diameter

- Standard: 88.000 ~ 88.012 mm (3.4646 ~ 3.4650 in.)
- Service Limit: 88.10 mm (3.468 in.)

Piston Wear Inspection

- Measure the outside diameter [A] of each piston 5 mm (0.20 in.) [B] up from the bottom of the piston at a right angle to the direction of the piston pin.
- ★ If the measurement is under service limit, replace the piston.

Piston Diameter

- Standard: 87.955 ~ 87.970 mm (3.4628 ~ 3.4634 in.)
- Service Limit: 87.80 mm (3.457 in.)

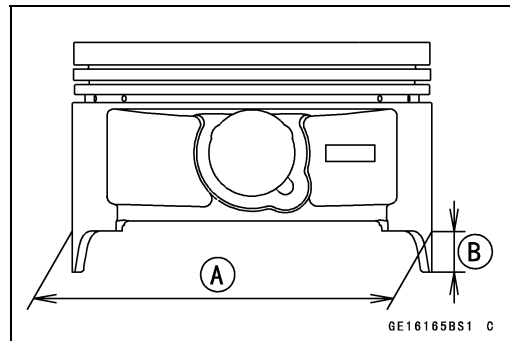

Piston/Cylinder Clearance Inspection

- Subtract the piston diameter from the cylinder inside diameter to get the piston/cylinder clearance.

Piston/Cylinder Clearance

- Standard: 0.030 ~ 0.057 mm (0.0012 ~ 0.0022 in.)

- ★ If the piston/cylinder clearance is less than the specified range, use a smaller piston or increase the cylinder inside diameter by honing.
- ★ If the piston/cylinder clearance is greater than specified range, use a larger piston.
- ★ If only a piston is replaced, the clearance may exceed the standard slightly. But it must not to be less than the minimum in order to avoid piston seizure.

Cylinders, Pistons

Piston Ring, Piston Ring Groove Wear Inspection

- Check for uneven groove wear by inspecting the ring seating.
- ★ The rings should fit perfectly parallel to groove surfaces. If not, replace the piston and all the piston rings.
- With the piston rings in their grooves, make several measurements with a thickness gauge [A] to determine piston ring/groove clearance.

Piston Ring/Groove Clearance

Standard:

| | |
|---------------|---|
| Top | 0.05 ~ 0.09 mm (0.002 ~ 0.004 in.) |
| Second | 0.03 ~ 0.07 mm (0.001 ~ 0.003 in.) |

Service Limit:

| | |
|---------------|-----------------------------|
| Top | 0.19 mm (0.0075 in.) |
| Second | 0.17 mm (0.0067 in.) |

- ★ If the piston ring groove clearance is greater than the service limit, measure the ring thickness and groove width as follows to decide whether to replace the rings, the piston or both.

Piston Ring Groove Width Inspection

- Measure the piston ring groove width.
- Use a vernier caliper at several points around the piston.

Piston Ring Groove Width

Standard:

| | |
|---------------|---|
| Top | 1.04 ~ 1.06 mm (0.0409 ~ 0.0417 in.) |
| Second | 1.02 ~ 1.04 mm (0.0402 ~ 0.0409 in.) |

Service Limit:

| | |
|---------------|-----------------------------|
| Top | 1.14 mm (0.0449 in.) |
| Second | 1.12 mm (0.0441 in.) |

- ★ If the width of any of the two grooves is wider than the service limit at any point, replace the piston.

Piston Ring Thickness Inspection

- Measure the piston ring thickness.
- Use a micrometer to measure at several points around the ring.

Piston Ring Thickness

Standard:

| | |
|---------------|---|
| Top | 0.97 ~ 0.99 mm (0.038 ~ 0.039 in.) |
| Second | 0.97 ~ 0.99 mm (0.038 ~ 0.039 in.) |

Service Limit:

| | |
|---------------|----------------------------|
| Top | 0.90 mm (0.035 in.) |
| Second | 0.90 mm (0.035 in.) |

- ★ If any of the measurements is less than the service limit on either of the rings, replace all the rings.

NOTE

- When using new rings in a used piston, check for uneven groove wear. The rings should fit perfectly parallel to the groove sides. If not, replace the piston.

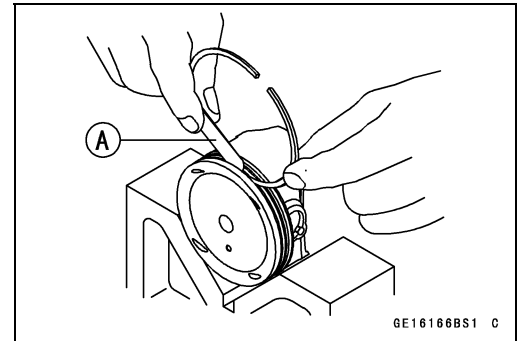

5-38 ENGINE TOP END

Cylinders, Pistons

Piston Ring End Gap Inspection

- Place the piston ring [A] inside the cylinder, using the piston to locate the ring squarely in place. Set it close to the bottom of the cylinder, where cylinder wear is low.
- Measure the gap [B] between the ends of the ring with a thickness gauge.

Piston Ring End Gap

Standard:

| | |
|---------------|---|
| Top | 0.20 ~ 0.35 mm (0.008 ~ 0.014 in.) |
| Second | 0.40 ~ 0.55 mm (0.016 ~ 0.022 in.) |
| Oil | 0.20 ~ 0.70 mm (0.008 ~ 0.028 in.) |

Service Limit:

| | |
|---------------|--------------------------|
| Top | 0.6 mm (0.02 in.) |
| Second | 0.8 mm (0.03 in.) |
| Oil | 1.0 mm (0.04 in.) |

- ★If the end gap of either ring is greater than the service limit, replace all the rings.

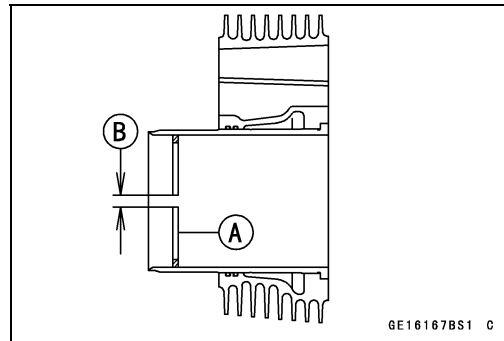

Mufflers

Muffler Removal

⚠ WARNING

The muffler can become extremely hot during normal operation and cause severe burns. Do not remove the muffler while it is hot.

- Remove:
 - Clamp Bolts (Loosen) [A]
 - Bolt [B]
 - Rear Muffler Cover [C]

- Remove:
 - Clamp Bolts (Loosen) [A]
 - Bolt [B]
 - Front Muffler Cover [C]

- Remove:
 - Muffler Mounting Nut [A], Collar and Damper
 - Muffler Mounting Bolt [B]

- Remove the muffler mounting bolts [A].

- Remove the front exhaust pipe holder nuts [A].

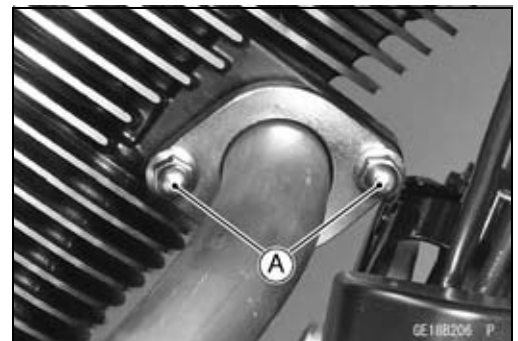
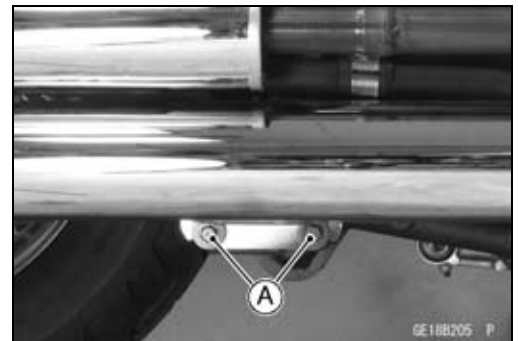
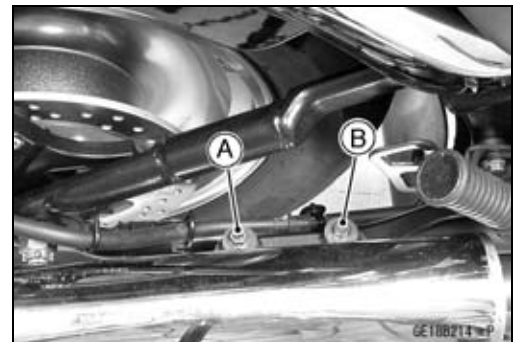
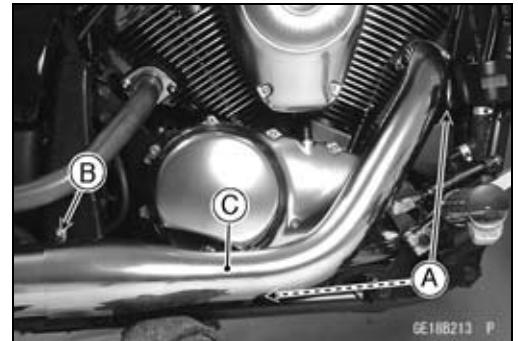
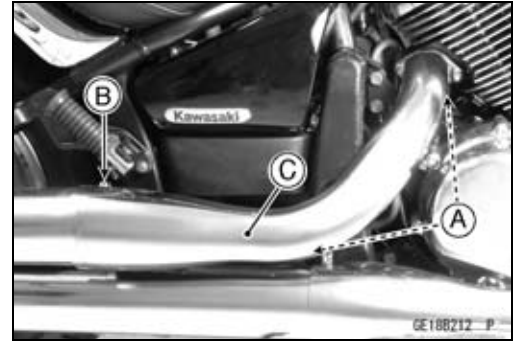

5-40 ENGINE TOP END

Mufflers

- Remove the rear exhaust pipe holder nuts [A].
- Remove the rear and front muffler jointed.

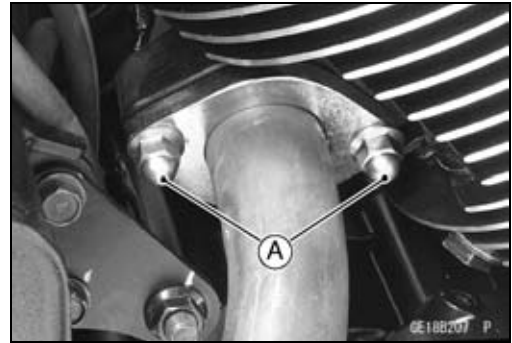

Muffler Installation

- Joint the rear and front muffler.
- Temporary tighten the muffler joint clamp bolt [A].

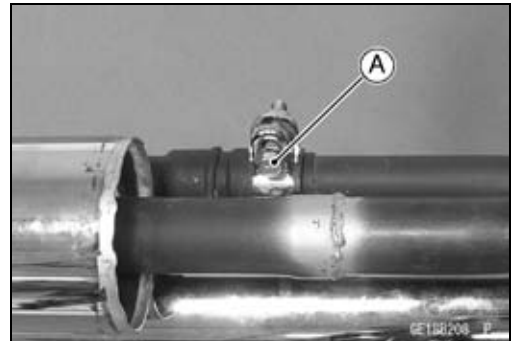

- Install the mufflers.
- Tighten:

Torque - Muffler Mounting Nut: 25 N·m (2.5 kgf·m, 18 ft·lb)
Muffler Mounting Bolts: 25 N·m (2.5 kgf·m, 18 ft·lb)
Exhaust Pipe Holder Nuts: 17 N·m (1.7 kgf·m, 12 ft·lb)
Muffler Joint Clamp Bolt: 17 N·m (1.7 kgf·m, 12 ft·lb)

- Install the muffler covers.
- Tighten:

Torque - Exhaust Pipe Cover Clamp Bolts: 6.9 N·m (0.70 kgf·m, 61 in·lb)
Exhaust Pipe Cover Bolt: 6.9 N·m (0.70 kgf·m, 61 in·lb)

Clutch

Table of Contents

| | |
|---|------|
| Exploded View | 6-2 |
| Specifications | 6-4 |
| Special Tool | 6-5 |
| Clutch Lever and Cable | 6-6 |
| Clutch Lever Free Play Inspection | 6-6 |
| Clutch Lever Free Play Adjustment | 6-6 |
| Clutch Cable Removal | 6-6 |
| Clutch Cable Installation | 6-6 |
| Clutch Cable Lubrication | 6-6 |
| Clutch Lever Holder Installation | 6-7 |
| Clutch Lever Installation | 6-7 |
| Right Engine Cover | 6-9 |
| Right Engine Cover Removal | 6-9 |
| Right Engine Cover Installation | 6-9 |
| Release Shaft Removal | 6-10 |
| Release Shaft Installation | 6-10 |
| Right Engine Cover Disassembly | 6-10 |
| Right Engine Cover Assembly | 6-10 |
| Clutch | 6-11 |
| Clutch Removal | 6-11 |
| Clutch Installation | 6-11 |
| Clutch Plate, Wear, Damage Inspection | 6-12 |
| Clutch Plate Warp Inspection | 6-13 |
| Clutch Spring Free Length Measurement | 6-13 |

6-2 CLUTCH

Exploded View

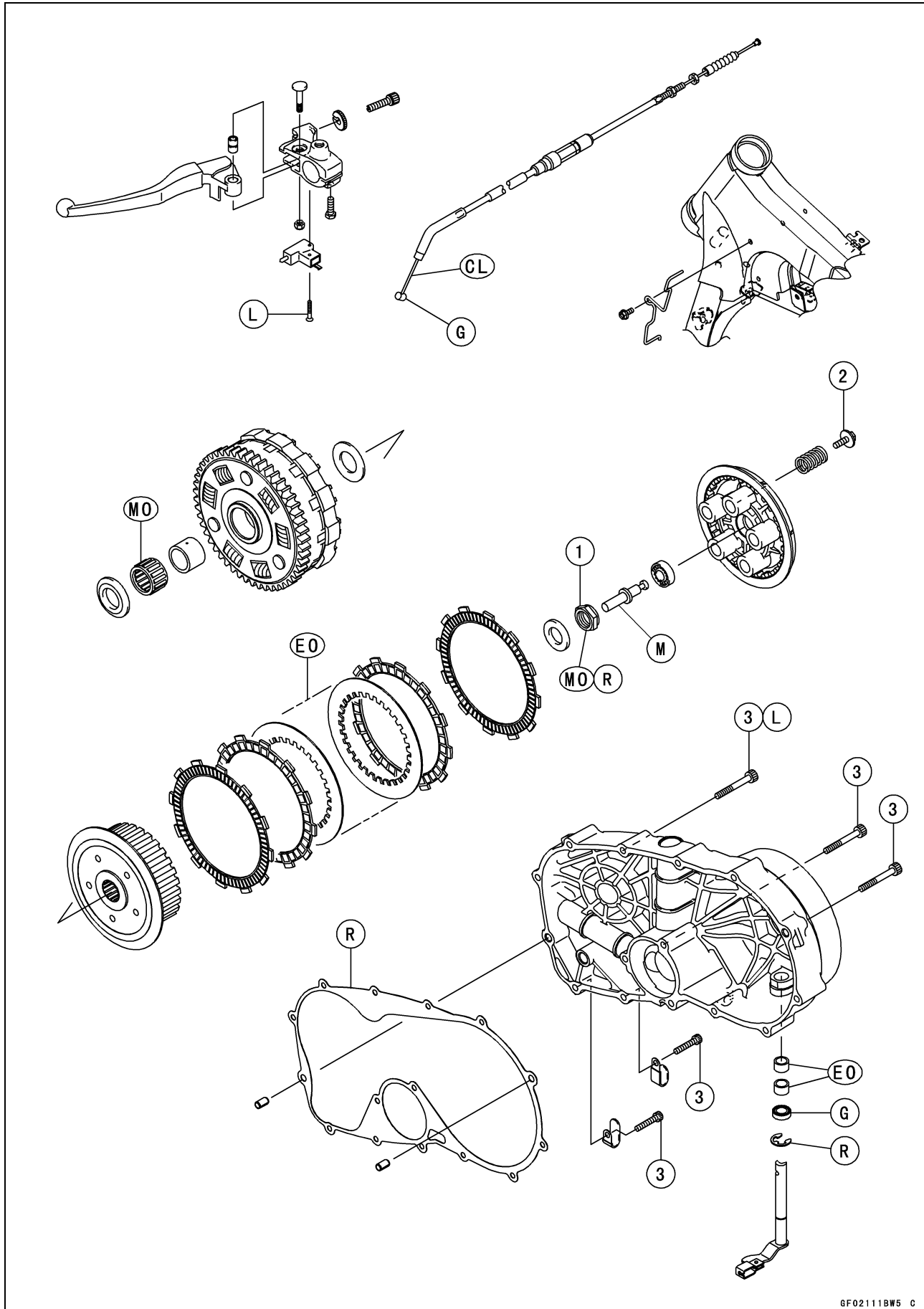

GF021118W5 C

Exploded View

| No. | Fastener | Torque | | | Remarks |
|-----|--------------------------|--------|-------|----------|---------|
| | | N·m | kgf·m | ft·lb | |
| 1 | Clutch Hub Nut | 130 | 13.3 | 96 | MO, R |
| 2 | Clutch Spring Bolts | 9.8 | 1.0 | 87 in·lb | |
| 3 | Right Engine Cover Bolts | 9.8 | 1.0 | 87 in·lb | L (1) |

CL: Apply cable lubricant.

EO: Apply engine oil.

G: Apply grease.

L: Apply a non-permanent locking agent.

M: Apply molybdenum disulfide grease.

MO: Apply molybdenum disulfide oil solution.

(mixture of the engine oil and molybdenum disulfide grease in a weight ratio 10 : 1)

R: Replacement Parts

6-4 CLUTCH

Specifications

| Item | Standard | Service Limit |
|-------------------------------|------------------------------------|--------------------|
| Clutch Lever Free Play | 2 ~ 3 mm (0.08 ~ 0.12 in.) | - - - |
| Clutch | | |
| Friction Plate Thickness: | 2.9 ~ 3.1 mm (0.1141 ~ 0.1220 in.) | 2.8 mm (0.110 in.) |
| Friction and Steel Plate Warp | 0.2 mm (0.008 in.) or less | 0.3 mm (0.012 in.) |
| Clutch Spring Free Length | 33.6 mm (1.32 in.) | 32.6 mm (1.28 in.) |

Special Tool

Clutch Holder:
57001-1243

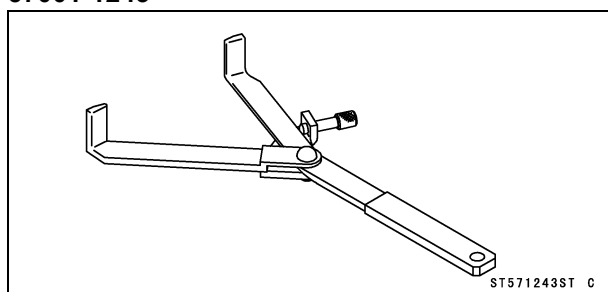

6-6 CLUTCH

Clutch Lever and Cable

Clutch Lever Free Play Inspection

- Refer to the Clutch Operation Inspection in the Periodic Maintenance chapter.

Clutch Lever Free Play Adjustment

- Refer to the Clutch Operation Inspection in the Periodic Maintenance chapter.

Clutch Cable Removal

- Remove the mufflers (see Muffler Removal in the Engine Top End chapter).
- Loosen the locknut [A] at the middle of the clutch cable.
- Turn the adjusting nut [B] to give the cable plenty of play.

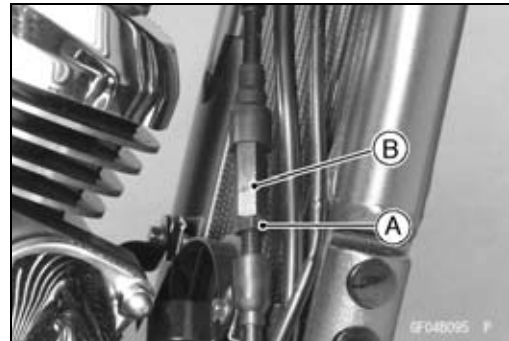

- Slide the dust cover [A] at the clutch cable lower end out of place.
- Loosen the nuts [B], and slide the lower end of the clutch cable to give the cable plenty of play.

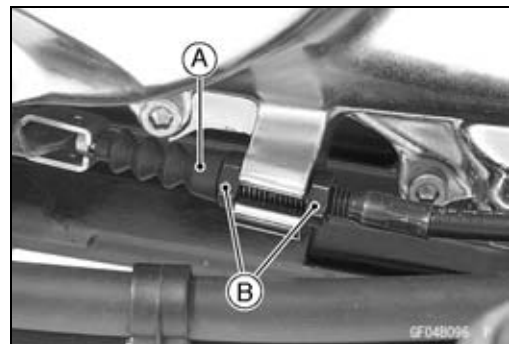

- Loosen the locknut [A] at the clutch lever, and screw in the adjuster [B].
- Line up the slots [C] in the clutch lever, locknut and adjuster, and then free the cable from the lever.
- Free the clutch inner cable tip from the clutch release lever.
- Pull the clutch cable out of the frame.

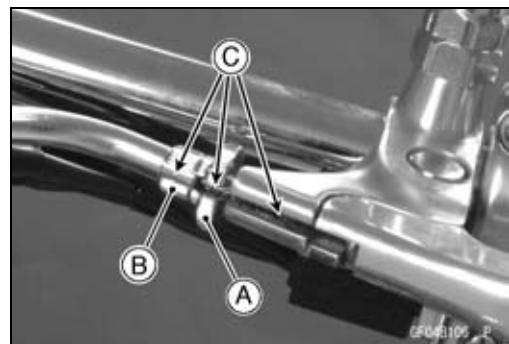

Clutch Cable Installation

- Run the clutch cable correctly (see Cable, Wire, and Hose Routing section in the Appendix chapter).
- Adjust the clutch cable (see Clutch Operation Inspection in the Periodic Maintenance chapter).

Clutch Cable Lubrication

- Refer to the Chassis Parts Lubrication in the Periodic Maintenance chapter.

Clutch Lever and Cable

Clutch Lever Holder Installation

- Install the clutch lever holder so that the mating surface [A] of the lever holder is aligned with the punch mark [B] of the handlebar.

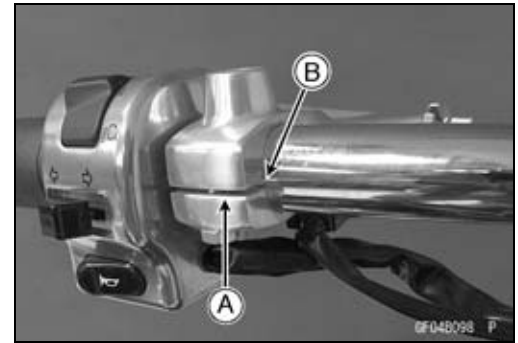

Clutch Lever Installation

⚠ WARNING

If the pin of the starter lockout switch has been broken, the starter lockout system will not work properly. This causing to the motorcycle moves suddenly at pushing the starter button if the transmission is in gear and the clutch lever is released. Check the starter lockout switch for operation when installing the clutch lever.

- Replace the locknut with a new one.
- Install the clutch lever [A] from frame left side [B] so that it may not damage a pin [C] of the starter lockout switch.

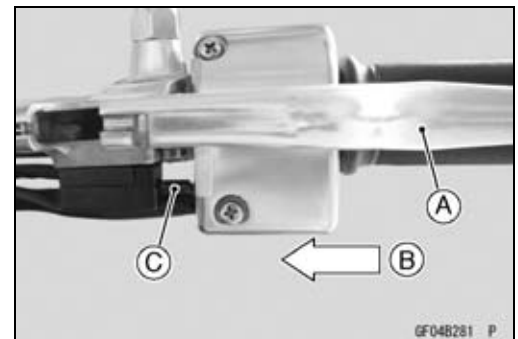

NOTICE

Do not install the clutch lever [A] from the front side [B]. The pin [C] of the starter lockout switch may be damaged in the projection [D] of a clutch lever.

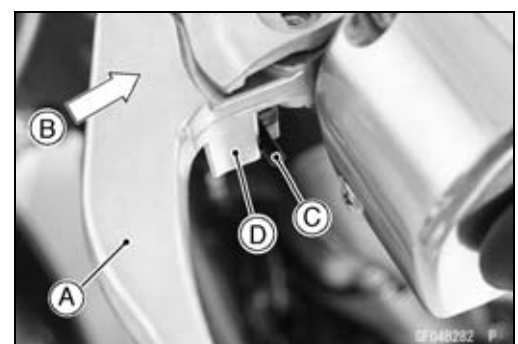

6-8 CLUTCH

Clutch Lever and Cable

- Tighten the bolt [A] and locknut [B].
- Install the upper end of the clutch cable (see Clutch Cable Installation).
- Adjust the clutch cable (see Clutch Operation Inspection in the Periodic Maintenance chapter).
- Check that the pin [C] of the starter lockout switch moves smoothly.

⚠ WARNING

Too much cable play can prevent clutch disengagement and cause an accident resulting in serious injury or death. When adjusting the clutch or replacing the cable, be sure the upper end of the clutch outer cable is fully seated in its fitting, or it could slip into place later, creating enough cable play to prevent clutch disengagement.

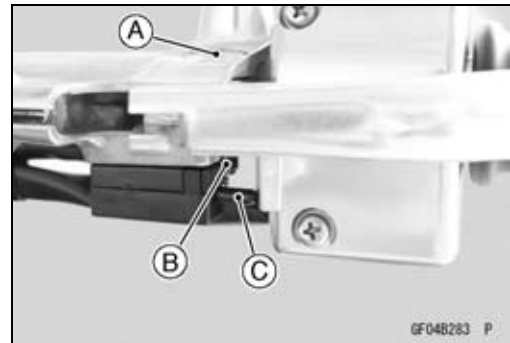

Right Engine Cover

Right Engine Cover Removal

- Drain:
 - Engine Oil (see Engine Oil Change in the Periodic Maintenance chapter)
 - Coolant (see Coolant Change in the Periodic Maintenance chapter)
- Remove:
 - Brake Pedal (see Brake Pedal Removal in the Brakes chapter)
 - Right Footpeg (see Footpeg Removal/Installation in the Frame chapter)
 - Mufflers (see Muffler Removal in the Engine Top End chapter)
 - Clutch Cable (see Clutch Cable Removal)
 - Downtube (see Downtube Removal in the Frame chapter)
 - Bolt [A]
 - Coolant Pipe [B]
- Remove the clutch cover bolts [A].
- Turn the release lever [B] toward the rear as shown in the figure, and remove the right engine cover.
- The water pipe [C] is removed along with the right engine cover.

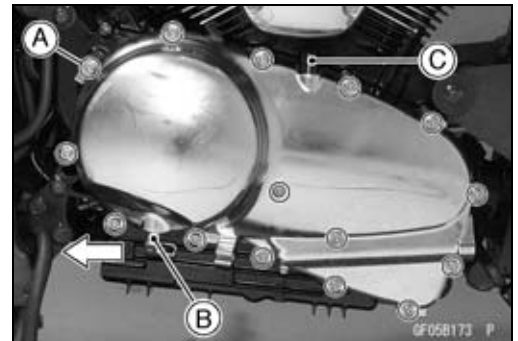
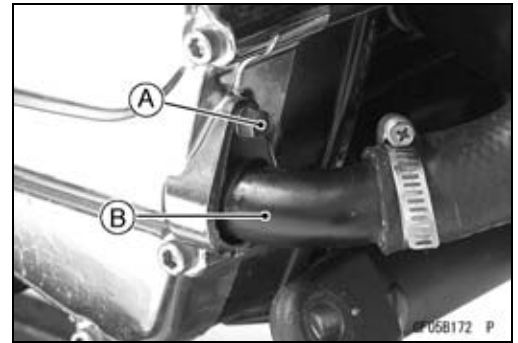

Right Engine Cover Installation

- Install the dowel pins [A], and replace the cover gasket with a new one.
- Check to see that the washer [B] is in place.
- Apply a non-permanent locking agent to the threads of the right engine cover bolt (L = 50 mm (2.0 in.)) [C].
- Install the seals [A] to the water pipe so that tapered side [B] facing the engine inside.
- Apply a soap and water solution to the seal. Do not apply a grease or oil to the seal.
- Be sure the water pipe installed correctly.
 - Right Engine Cover Side [C]
 - Crankcase Side [D]
- Tighten:
 - Torque - Right Engine Cover Bolts: 9.8 N·m (1.0 kgf·m, 87 in·lb)**

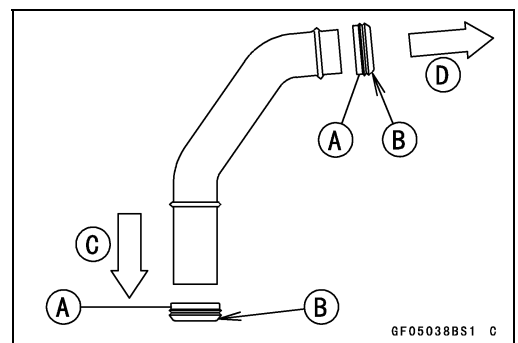
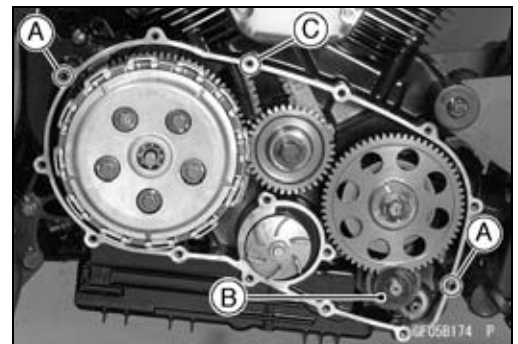

6-10 CLUTCH

Right Engine Cover

Release Shaft Removal

NOTICE

Do not remove the clutch release lever and shaft assembly unless it is absolutely necessary. If removed, the oil seal replacement may be required.

- Remove the right engine cover (see Right Engine Cover Removal).
- Remove the circlip [A] from the release shaft.
- Pull the lever and shaft assembly [B] out of the right engine cover.

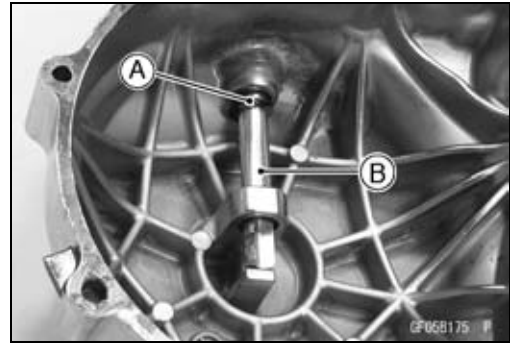

Release Shaft Installation

- Apply grease to the oil seal lip [A] on the lower ridge of the right engine cover.
- Apply engine oil to the needle bearings [B] in the hole of the right engine cover.
- Insert the release shaft [C] straight into the lower hole of the right engine cover.

NOTICE

When inserting the release shaft, be careful not to remove the spring of the oil seal.

- Install the new circlip.

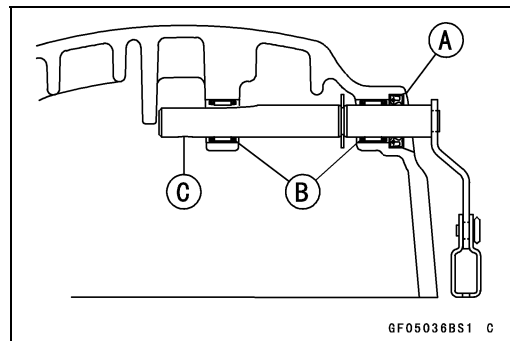

Right Engine Cover Disassembly

- Remove:
 - Oil Seal [A]
 - Needle Bearings [B]

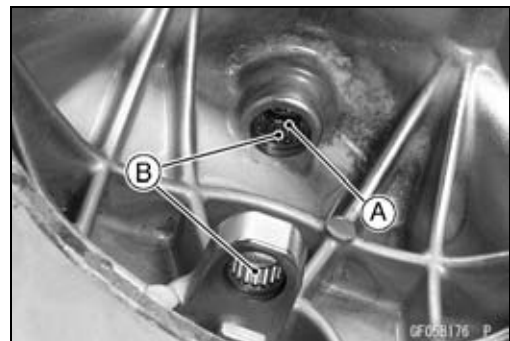

Right Engine Cover Assembly

- Replace the needle bearings and oil seal with new ones.

NOTE

○ Install the needle bearings so that the manufacture's mark face out.

- Install the needle bearings [A] and oil seal [B] position as shown in the figure.
- Press [C] the outer needle bearing so that the bearing surface [D] is flush with the housing end [E] of right engine cover.
- Press [F] the inner needle bearing so that the bearing both surface does not protrude from the both housing ends [G] of right engine cover.

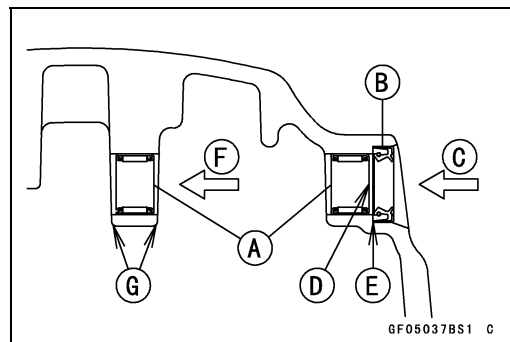

Clutch

Clutch Removal

- Remove:
 - Right Engine Cover (see Right Engine Cover Removal)
 - Clutch Spring Bolts [A]
 - Clutch Springs
 - Clutch Spring Plate [B] (with thrust bearing and pusher [C])

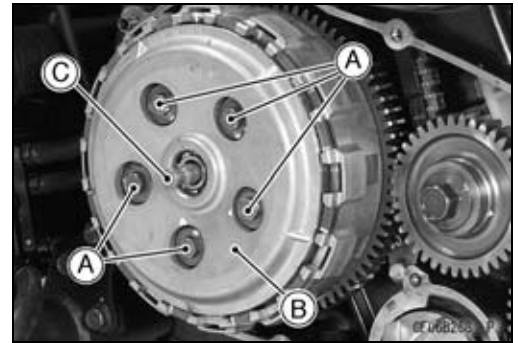

- Remove:
 - Friction Plates and Steel Plates
 - Clutch Hub Nut [A]
- Holding the clutch hub [B], remove the nut.
 - Special Tool - Clutch Holder [C]: 57001-1243**
- Remove the clutch hub.



- Remove:
 - Spacer [A]
 - Clutch Housing [B], Needle Bearing and Bushing
 - Thrust Washer

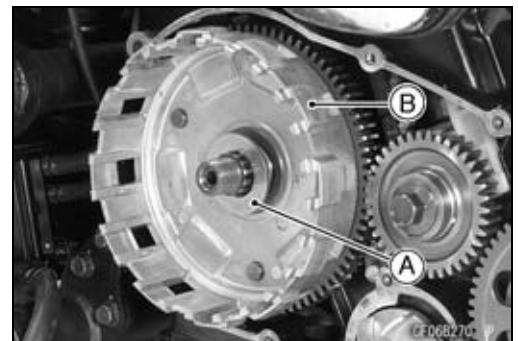

Clutch Installation

- Install the thrust washer [A] to the drive shaft so that the tapered side [B] faces inward.
- Apply molybdenum disulfide oil solution to the needle bearing.
- Install the bushing and needle bearing to the drive shaft.

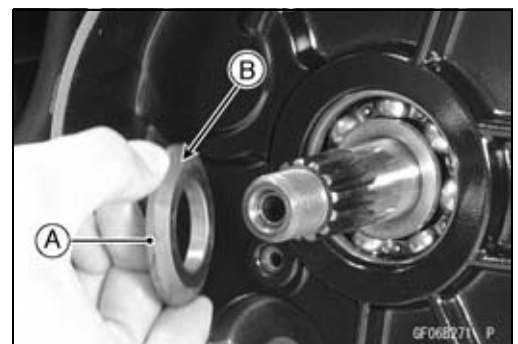

- Install:
 - Clutch Housing [A]
 - Spacer [B]
 - Clutch Hub

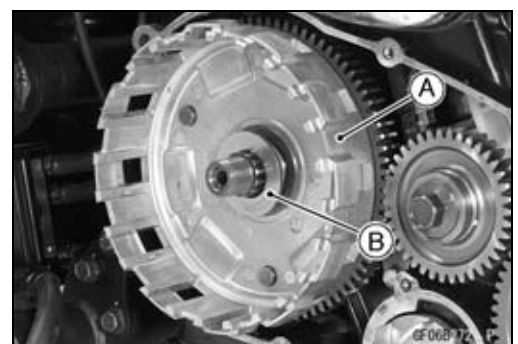

6-12 CLUTCH

Clutch

- Install the washer so that the OUTSIDE mark [A] faces outward.



- Replace the clutch hub nut with a new one.
- Apply molybdenum disulfide oil solution to seating surface of the hub nut.
- Holding the clutch hub, tighten the clutch hub nut.

Special Tool - Clutch Holder: 57001-1243

Torque - Clutch Hub Nut: 130 N·m (13.3 kgf·m, 96 ft·lb)

- Install the friction plates and steel plates, starting with a friction plate and alternating them.
- Install the friction plates so that the plates of having more lining blocks [A] than other plate [B] are placed at both ends [C].

13088-0023 [D]

13088-1133 [E]

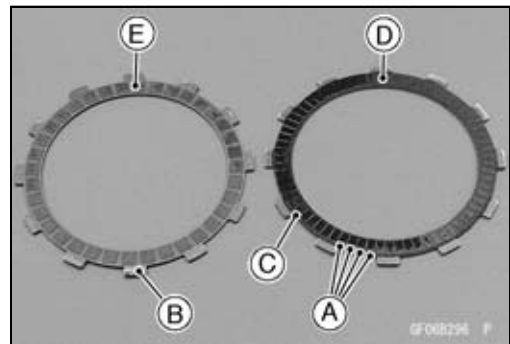

NOTICE

If new dry friction plates and steel plates are installed, apply engine oil to the surfaces of each plate to avoid clutch plate seizure.

- Install the last friction plate [A] fitting the tangs in the grooves in the housing as shown in the figure.
- Install the clutch spring plate and springs, and tighten the clutch spring bolts.

Torque - Clutch Spring Bolts: 9.8 N·m (1.0 kgf·m, 87 in·lb)

- Install the right engine cover (see Right Engine Cover Installation).

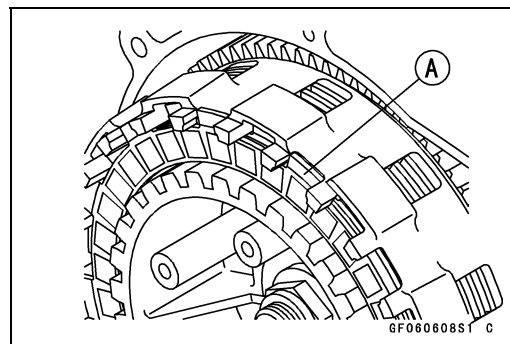

Clutch Plate, Wear, Damage Inspection

- Visually inspect the friction and steel plates for signs of seizure, overheating (discoloration), or uneven wear.
- Measure the thickness of each friction plate [A] at several points.
- ★ If any plates show signs of damage, or if they have worn past the service limit, replace them with new ones.

Friction Plate Thickness

Standard:

13088-0023 2.9 ~ 3.1 mm (0.1141 ~ 0.1220 in.)

13088-1133 2.92 ~ 3.08 mm (0.1149 ~ 0.1212 in.)

Service Limit: 2.8 mm (0.110 in.)

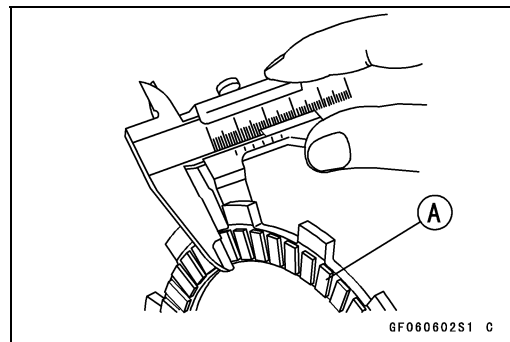

Clutch

Clutch Plate Warp Inspection

- Place each friction plate or steel plate on a surface plate and measure the gap between the surface plate [A] and each friction plate or steel plate [B] with a thickness gauge [C]. The gap is the amount of friction or steel plate warp.
- ★ If any plate is warped over the service limit, replace it with a new one.

Friction and Steel Plate Warp

Standard: 0.2 mm (0.008 in.) or less

Service Limit: 0.3 mm (0.012 in.)

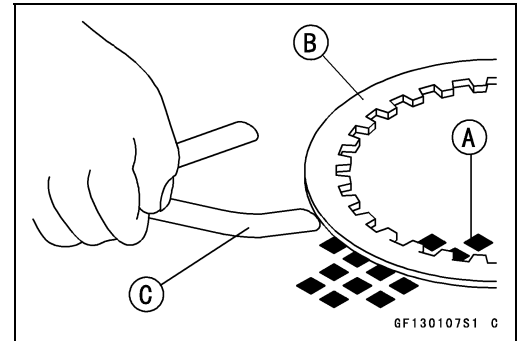

Clutch Spring Free Length Measurement

- Measure the free length of the clutch springs [A].
- ★ If any spring is shorter than the service limit, it must be replaced.

Clutch Spring Free Length

Standard: 33.6 mm (1.32 in.)

Service Limit: 32.6 mm (1.28 in.)

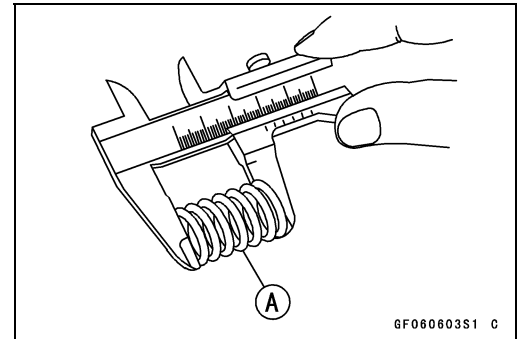

Engine Lubrication System

Table of Contents

| | |
|---|------|
| Exploded View..... | 7-2 |
| Engine Oil Flow Chart..... | 7-4 |
| Specifications | 7-5 |
| Special Tools and Sealant | 7-6 |
| Engine Oil and Oil Filter..... | 7-7 |
| Oil Level Inspection..... | 7-7 |
| Engine Oil Change..... | 7-7 |
| Oil Filter Change | 7-7 |
| Oil Screen Cleaning..... | 7-8 |
| Oil Pressure Relief Valve..... | 7-9 |
| Oil Pressure Relief Valve Removal/Installation..... | 7-9 |
| Oil Pressure Relief Valve Inspection..... | 7-9 |
| Oil Pump, Oil Pump Drive Chain | 7-10 |
| Oil Pump Removal | 7-10 |
| Oil Pump Installation | 7-10 |
| Oil Pump Drive Chain Guide Installation | 7-11 |
| Oil Pressure Measurement | 7-12 |
| Oil Pressure Measurement | 7-12 |
| Oil Pressure Switch | 7-13 |
| Oil Pressure Switch Removal | 7-13 |
| Oil Pressure Switch Installation | 7-13 |
| Oil Pipe and Oil Hose | 7-14 |
| Oil Pipe (Crankcase Outside) Removal | 7-14 |
| Oil Pipe (Crankcase Outside) Installation | 7-14 |
| Oil Pipe (Crankcase Inside) Removal | 7-14 |
| Oil Pipe (Crankcase Inside) Installation..... | 7-14 |
| Blowby Gas System Inspection | 7-15 |
| Breather Drain Cleaning | 7-15 |

7-2 ENGINE LUBRICATION SYSTEM

Exploded View

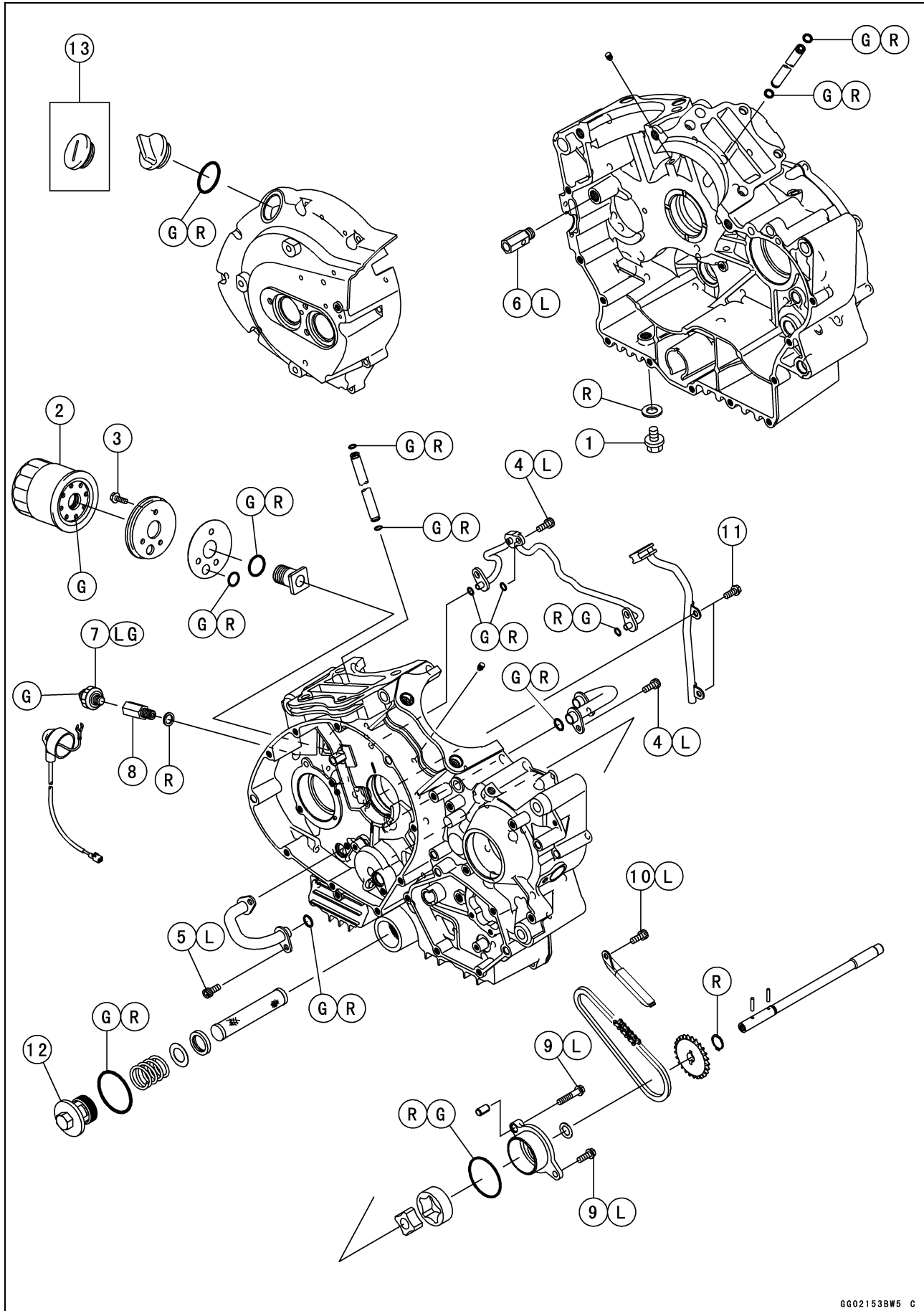

GG021538W5 C

ENGINE LUBRICATION SYSTEM 7-3

Exploded View

| No. | Fastener | Torque | | | Remarks |
|-----|------------------------------------|--------|-------|----------|---------|
| | | N·m | kgf·m | ft·lb | |
| 1 | Engine Oil Drain Plug | 20 | 2.0 | 15 | |
| 2 | Oil Filter | 18 | 1.8 | 13 | |
| 3 | Oil Filter Plate Bolts | 7.8 | 0.80 | 69 in·lb | |
| 4 | Oil Pipe Bolts (Crankcase Inside) | 9.8 | 1.0 | 87 in·lb | L |
| 5 | Oil Pipe Bolts (Crankcase Outside) | 9.8 | 1.0 | 87 in·lb | L |
| 6 | Oil Pressure Relief Valve | 15 | 1.5 | 11 | L |
| 7 | Oil Pressure Switch | 15 | 1.5 | 11 | LG |
| 8 | Oil Pressure Switch Adapter | 20 | 2.0 | 15 | |
| 9 | Oil Pump Cover Bolts | 9.8 | 1.0 | 87 in·lb | L |
| 10 | Oil Pump Drive Chain Guide Bolt | 9.8 | 1.0 | 87 in·lb | L |
| 11 | Oil Return Pipe Bolts | 9.8 | 1.0 | 87 in·lb | |
| 12 | Oil Screen Plug | 20 | 2.0 | 15 | |

13. VN900C7 ~ CA

G: Apply grease.

L: Apply a non-permanent locking agent.

LG: Apply liquid gasket.

R: Replacement Parts

7-4 ENGINE LUBRICATION SYSTEM

Engine Oil Flow Chart

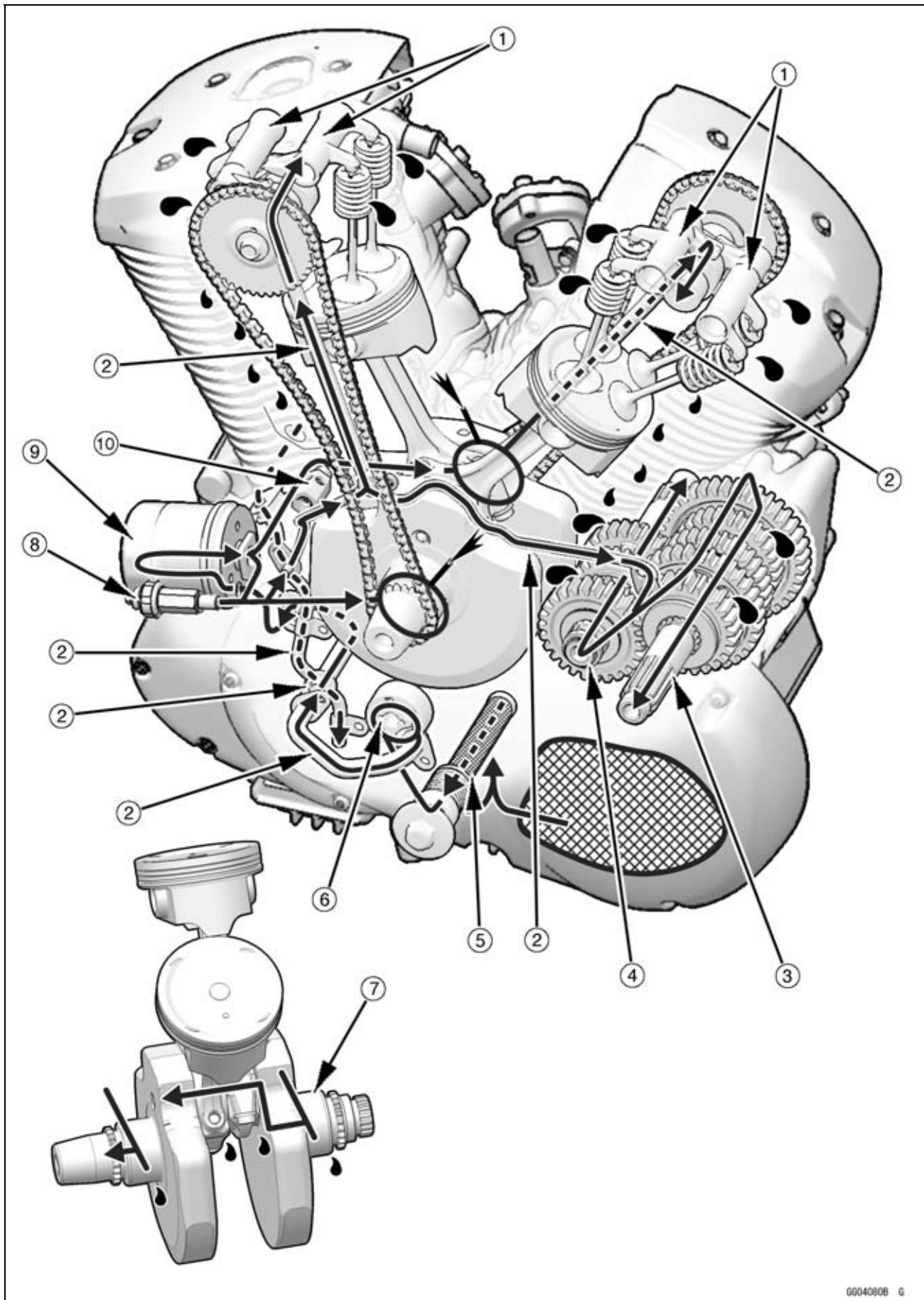

GG04080B G

- | | | |
|-----------------|------------------------|-------------------------------|
| 1. Rocker Arms | 5. Oil Screen | 9. Oil Filter |
| 2. Oil Pipes | 6. Oil Pump | 10. Oil Pressure Relief Valve |
| 3. Output Shaft | 7. Crankshaft | |
| 4. Drive Shaft | 8. Oil Pressure Switch | |

ENGINE LUBRICATION SYSTEM 7-5

Specifications

| Item | Standard |
|---|---|
| Engine Oil Type Viscosity Capacity Level | API SG, SH, SJ, SL or SM with JASO MA, MA1 or MA2 SAE 10W-40 3.0 L (3.2 US qt) (when filter is not removed) 3.2 L (3.4 US qt) (when filter is removed) 3.7 L (3.9 US qt) (when engine is completely dry) Between upper and lower level lines (after idling or running) |
| Oil Pressure Measurement Oil Pressure | 294 ~ 392 kPa (3.0 ~ 4.0 kgf/cm ² , 42.6 ~ 56.8 psi) at 4 000 r/min (rpm), Oil Temperature 90°C (194°F) |

7-6 ENGINE LUBRICATION SYSTEM

Special Tools and Sealant

Oil Pressure Gauge, 10 kgf/cm²:

57001-164

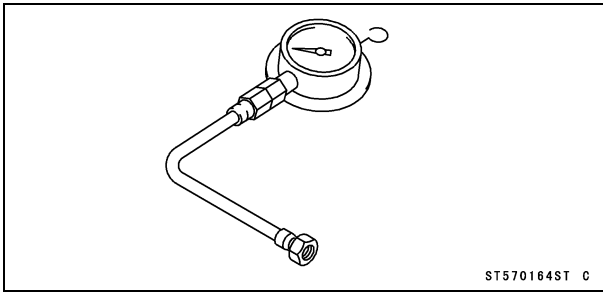

Oil Filter Wrench:

57001-1249

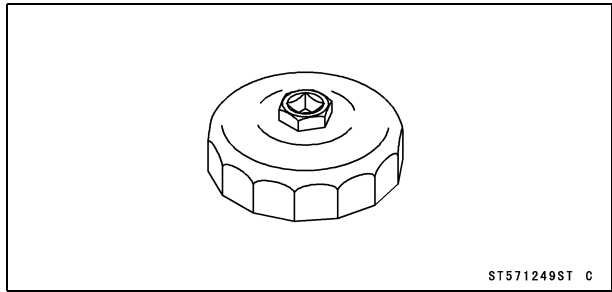

Oil Pressure Gauge Adapter, M10 × 1.25:

57001-1182

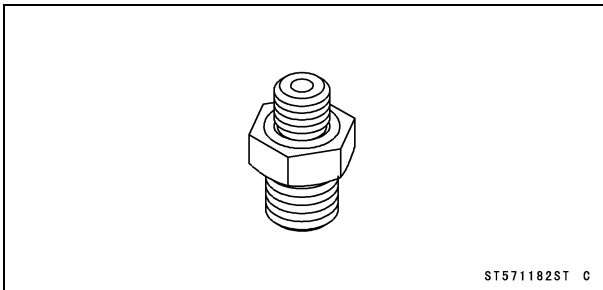

Liquid Gasket, TB1211:

56019-120

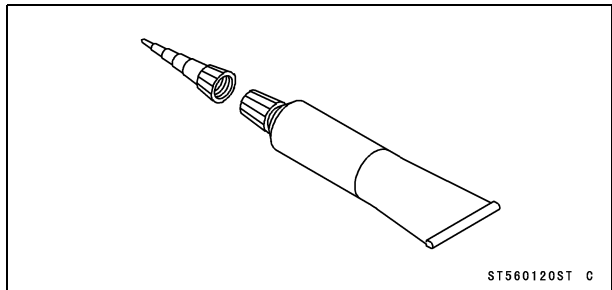

Engine Oil and Oil Filter

⚠ WARNING

Vehicle operation with insufficient, deteriorated, or contaminated engine oil will cause accelerated wear and may result in engine seizure, accident, and injury. Check the oil level before each use and change the oil and filter according to the periodic maintenance chart.

Oil Level Inspection

- Check that the engine oil level is between the upper [A] and lower [B] level lines next to the oil level inspection window [C].

NOTE

- Situate the motorcycle so that it is perpendicular to the ground.
- If the motorcycle has just been used, wait several minutes for all the oil to drain down.
- If the oil has just been changed, start the engine and run it for several minutes at idle speed. This fills the oil filter with oil. Stop the engine, then wait several minutes until the oil settles.

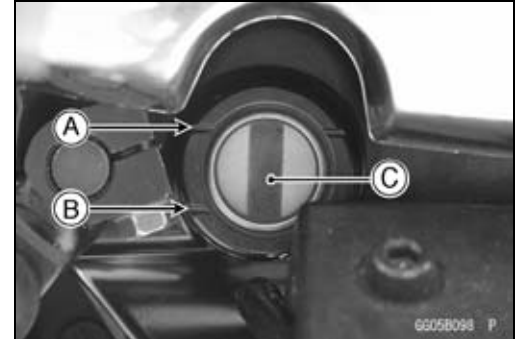

NOTICE

A lack of oil can cause seizure or serious damage to engine parts. During engine start-up it may take a few seconds for the oil pump to deliver oil throughout the engine. Do not rev or race the engine immediately after starting; allow it to properly warm up. A lighted oil pressure **WARNING** light signals an extremely low oil level or a malfunction with the lubrication system that could lead to catastrophic engine failure, creating the possibility of crash resulting in serious injury or death. If the oil pressure **WARNING** light illuminates, safely pull to the side of the road and stop the engine. Check the oil level and/or have the engine inspected by a Kawasaki dealer.

- ★ If the oil level is too high, remove the excess oil, using a syringe or some other suitable device.
- ★ If the oil level is too low, add the correct amount of oil through the oil filter opening. Use the same type and make of oil that is already in the engine.

NOTE

- If the engine oil type and make are unknown, use any brand of the specified oil to top off the level in preference to running the engine with the oil level low. Then at your earliest convenience, change the oil completely.

Engine Oil Change

- Refer to the Engine Oil Change in the Periodic Maintenance chapter.

Oil Filter Change

- Refer to the Oil Filter Replacement in the Periodic Maintenance chapter.

7-8 ENGINE LUBRICATION SYSTEM

Engine Oil and Oil Filter

Oil Screen Cleaning

- Drain the engine oil (see Engine Oil Change in the Periodic Maintenance chapter).
- Remove the oil screen plug [A], spring and washer.

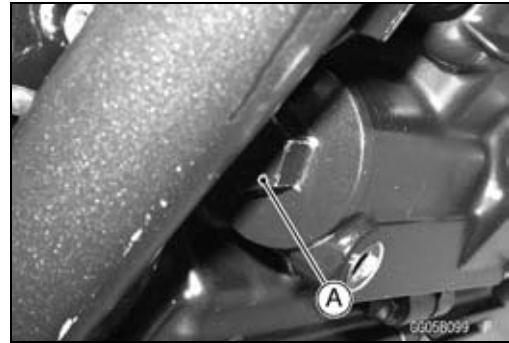

- Pull out the oil screen [A].
- Clean the screen with high flash-point solvent.

⚠ WARNING

Gasoline and low flash-point solvents can be flammable and/or explosive and cause severe burns. Clean the oil screen in a well-ventilated area, and take care that there are no sparks or flame anywhere near the working area; this includes any appliance with a pilot light. Do not use gasoline or a low flash-point solvent to clean the oil screen.

- Check the screen carefully for any damage.
- ★ If the screen is damaged, replace it with a new one.
- Replace the O-ring [B] with a new one.
- Install:
 - Oil Screen and Rubber Gasket [C]
 - Washer [D]
 - Spring [E]
- Apply grease to the O-ring, and tighten the plug.
Torque - Oil Screen Plug: 20 N·m (2.0 kgf·m, 15 ft·lb)

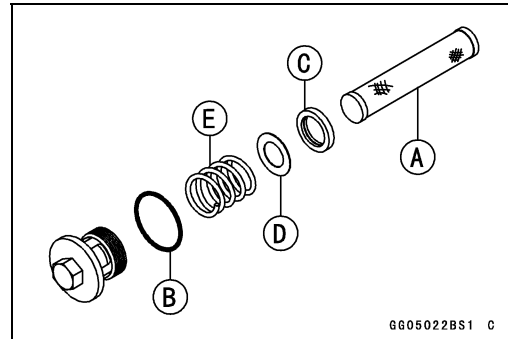

Oil Pressure Relief Valve

Oil Pressure Relief Valve Removal/Installation

- Split the crankcase (see Crankcase Splitting in the Crankshaft/Transmission chapter).
- Remove the relief valve [A] from the right crankcase.
- Apply a non-permanent locking agent to the threads of the relief valve, and tighten it.

Torque - Oil Pressure Relief Valve: 15 N·m (1.5 kgf·m, 11 ft·lb)

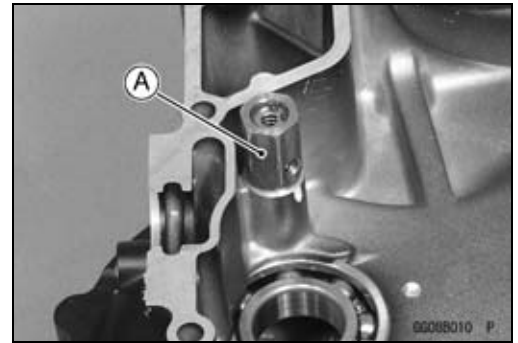

Oil Pressure Relief Valve Inspection

- Check to see if the steel ball [A] inside the valve slides smoothly when pushing it in with a wooden or other soft rod, and see if it comes back to its seat by valve spring pressure [B].

NOTE

○ *Inspect the valve in its assembled state. Disassembly and assembly may change the valve performance.*

- ★ If any rough spots are found during above inspection, wash the valve clean with a high flash-point solvent and blow out any foreign particles that may be in the valve with compressed air.

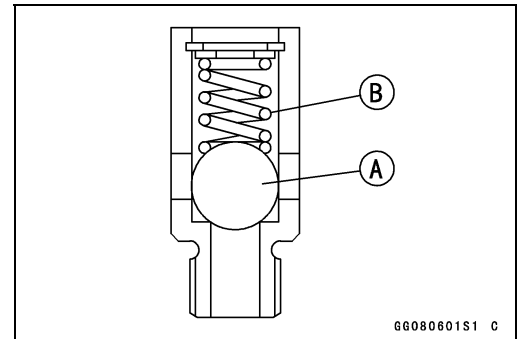

⚠ WARNING

Gasoline and low flash-point solvents can be flammable and/or explosive and cause severe burns. Clean the engine parts in a well-ventilated area, and take care that there is no spark or flame anywhere near the working areas. Do not use gasoline or low flash-point solvents to clean parts.

- ★ If cleaning does not solve the problem, replace the relief valve as an assembly. The relief valve is precision made with no allowance for replacement of individual parts.

7-10 ENGINE LUBRICATION SYSTEM

Oil Pump, Oil Pump Drive Chain

Oil Pump Removal

- Split the crankcase (see Crankcase Splitting in the Crankshaft/Transmission chapter).
- Remove:
 - Crankshaft (see Crankshaft Removal in the Crankshaft/Transmission chapter)
 - Oil Pipes (see Oil Pipe (Crankcase Inside) Removal)
 - Oil Pump Cover Bolts [A]
- Remove the following parts as a set.
 - Sprocket [B]
 - Oil Pump Shaft [C]
 - Oil Pump Cover [D]
 - Rotors
 - Balancer Shaft [E]

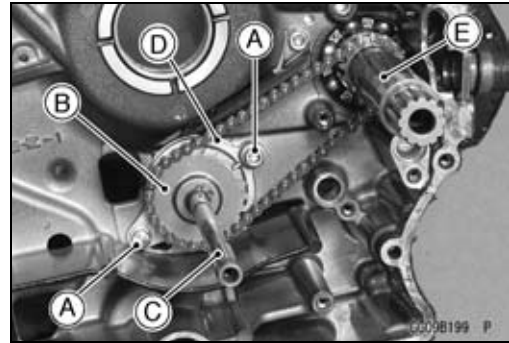

Oil Pump Installation

- Replace the circlip [A] with a new one.
- Assemble:
 - Oil Pump Shaft [B]
 - Oil Pump Cover [C]
 - Washer [D]
 - Pins [E]
 - Rotors [F]
 - Sprocket [G]
 - Circlip
- Install a new circlip on the shaft so that the sharp edge faces away from the sprocket.
- Check that the dowel pin [A] is in place.
- Replace the O-ring [B] with a new one.
- Apply grease to the O-ring on the pump body.

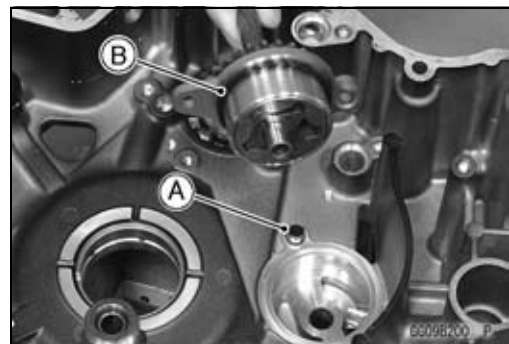
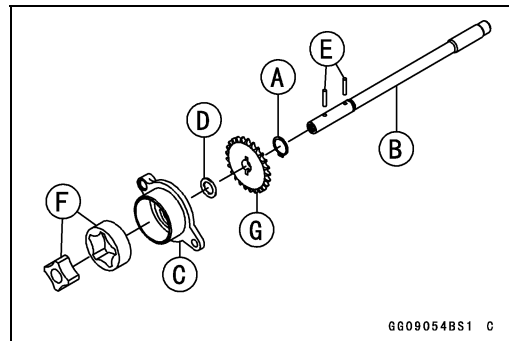

- Install the oil pump assembly [A] and balancer shaft [B] along with the oil pump chain.
- Apply a non-permanent locking agent to the threads of the oil pump cover bolts [C], and tighten them.

Torque - Oil Pump Cover Bolts: 9.8 N·m (1.0 kgf·m, 87 in·lb)

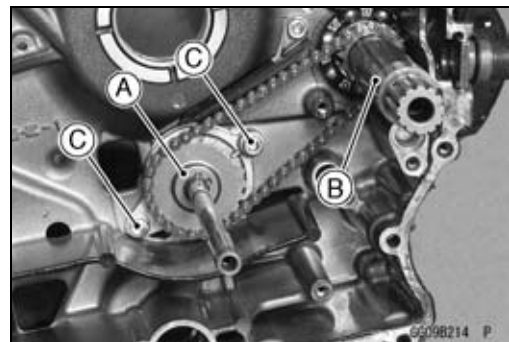

Oil Pump, Oil Pump Drive Chain

Oil Pump Drive Chain Guide Installation

- Install the chain guide [A] to the left crankcase.
- Apply a non-permanent locking agent to the threads of the chain guide bolt [B], and tighten it.

Torque - Oil Pump Drive Chain Guide Bolt: 9.8 N·m (1.0 kgf·m, 87 in·lb)

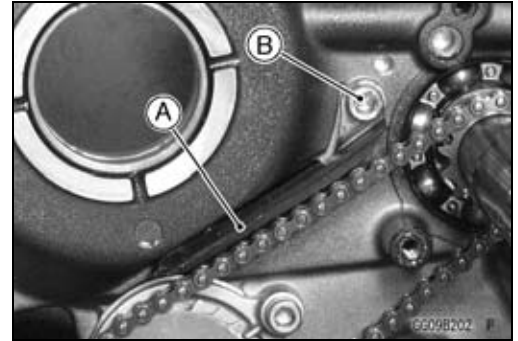

7-12 ENGINE LUBRICATION SYSTEM

Oil Pressure Measurement

Oil Pressure Measurement

- Remove the regulator/rectifier (see Regulator/Rectifier Removal in the Electrical System chapter).
- Remove the oil pressure switch together with the adapter (see Oil Pressure Switch Removal) without draining the engine oil.
- Install the oil pressure gauge and adapter.

Special Tools - Oil Pressure Gauge, 10 kgf/cm² [A]: 57001-164

Oil Pressure Gauge Adapter, M10 × 1.25: 57001-1182

- Run the engine at the specified speed, and read the oil pressure gauge.
- ★ If the oil pressure is significantly below the specification, inspect the oil pump and relief valve.
- ★ If the oil pump and relief valve are not at fault, inspect the rest of the lubrication system.

Oil Pressure

Standard: 294 ~ 392 kPa (3.0 ~ 4.0 kgf/cm², 42.6 ~ 56.8 psi) at 4 000 r/min (rpm), oil temperature 90°C (194°F)

- Stop the engine.
- Remove the oil pressure gauge and adapter.

⚠ WARNING

Hot oil can cause severe burns. Beware of hot engine oil that will drain through the oil passage when the gauge adapter is removed.

- Install the removed parts (see appropriate chapters).

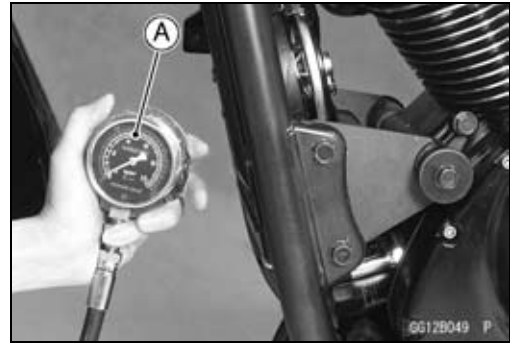

Oil Pressure Switch

Oil Pressure Switch Removal

- Drain the engine oil (see Engine Oil Change in the Periodic Maintenance chapter).
- Remove:
 - Switch Cover [A]
 - Switch Terminal Bolt [B]
 - Oil Pressure Switch [C]

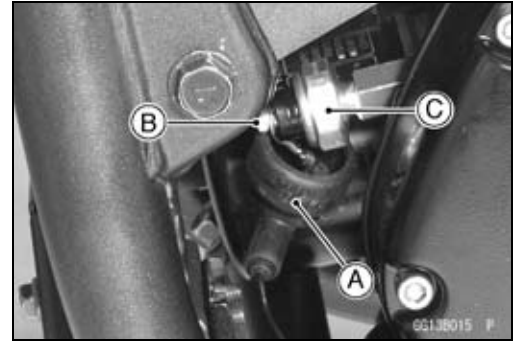

Oil Pressure Switch Installation

- Apply silicone sealant to the threads of the oil pressure switch, and tighten it.
Sealant - Liquid Gasket, TB1211: 56019-120
Torque - Oil Pressure Switch: 15 N·m (1.5 kgf·m, 11 ft·lb)
- Tighten the terminal bolt securely.
- Apply grease to the terminal, and install the switch cover.

7-14 ENGINE LUBRICATION SYSTEM

Oil Pipe and Oil Hose

Oil Pipe (Crankcase Outside) Removal

- Remove:
 - Alternator Cover (see Alternator Cover Removal in the Electrical System chapter)
 - Oil Pipe Bolts [A]
 - Oil Pipe [B]

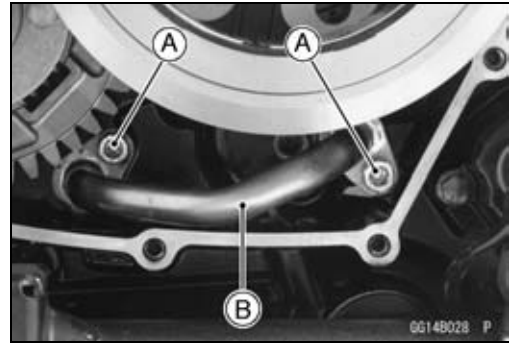

Oil Pipe (Crankcase Outside) Installation

- Apply grease to the O-rings [A].
 - Plug the oil passage hole [A] with a clean cloth for prevent the bolt from dropping.
 - Apply a non-permanent locking agent to the threads of the bolts [B], and tighten them.
- Torque - Oil Pipe Bolts (Crankcase Outside): 9.8 N·m (1.0 kgf·m, 87 in·lb)**

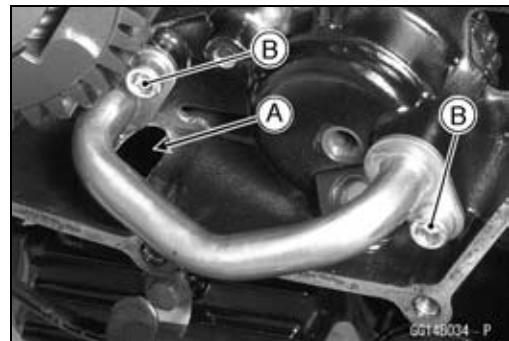

Oil Pipe (Crankcase Inside) Removal

- Split the crankcase (see Crankcase Splitting in the Crankshaft/Transmission chapter).
- Remove:
 - Crankshaft (see Crankshaft Removal in the Crankshaft/Transmission chapter)
 - Oil Return Pipe Bolts [A]
 - Oil Return Pipe [B]
 - Oil Pipe Bolts [C]
 - Oil Pipes [D]

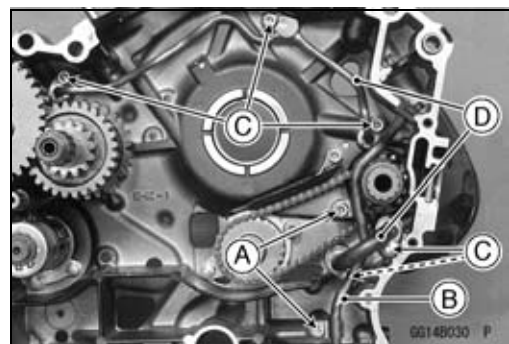

Oil Pipe (Crankcase Inside) Installation

- Replace the O-rings [A] with new ones.
 - Apply grease to the O-rings.
 - Install the oil pipes [B].
 - Apply a non-permanent locking agent to the threads of the bolts, and tighten them.
- Torque - Oil Pipe Bolts (Crankcase Inside): 9.8 N·m (1.0 kgf·m, 87 in·lb)**

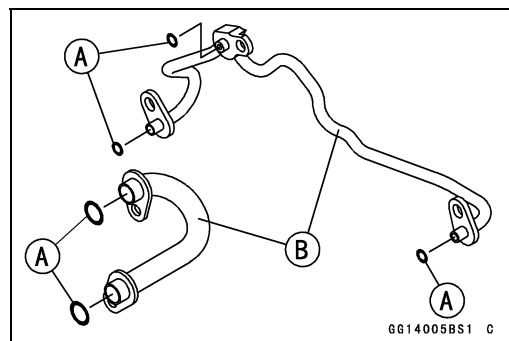

Oil Pipe and Oil Hose

- Install the oil return pipe [A].
- Tighten:
 - Torque - Oil Return Pipe Bolts [B]: 9.8 N·m (1.0 kgf·m, 87 in·lb)

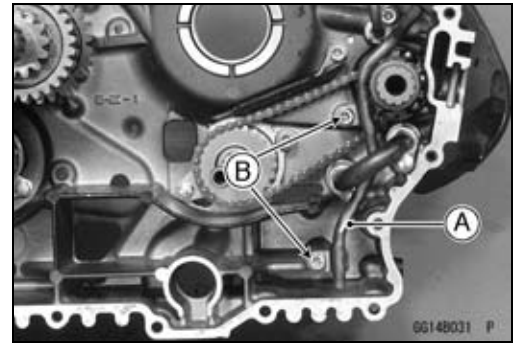

Blowby Gas System Inspection

- Remove the ignition coil with the bracket (see Ignition Coil Removal in the Electrical System chapter).
- Be certain that the hose is routed without being flattened or kinked, and is connected correctly to the air cleaner base.
- ★ If it is not, correct it.
- Inspect the breather hose [A], and the air cleaner drain cap for damage or signs of deterioration.
- The hose and drain cap should not be hard and brittle, nor should be soft or swollen.
- ★ Replace them if any cracks or swelling are noticed.
- Check that the hose is securely connected.

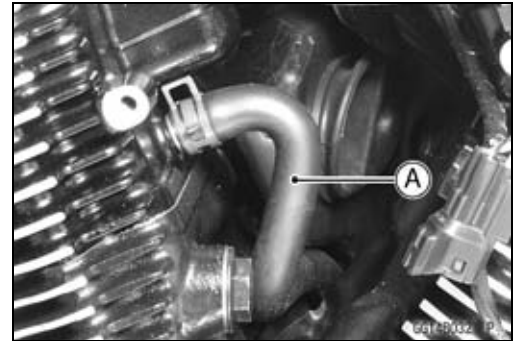

Breather Drain Cleaning

- Refer to the Air Cleaner Housing Installation in the Fuel System (DFI) chapter.

Engine Removal/Installation

Table of Contents

| | |
|-----------------------------------|-----|
| Exploded View..... | 8-2 |
| Special Tool | 8-4 |
| Engine Removal/Installation | 8-5 |
| Engine Removal..... | 8-5 |
| Engine Installation..... | 8-8 |

8-2 ENGINE REMOVAL/INSTALLATION

Exploded View

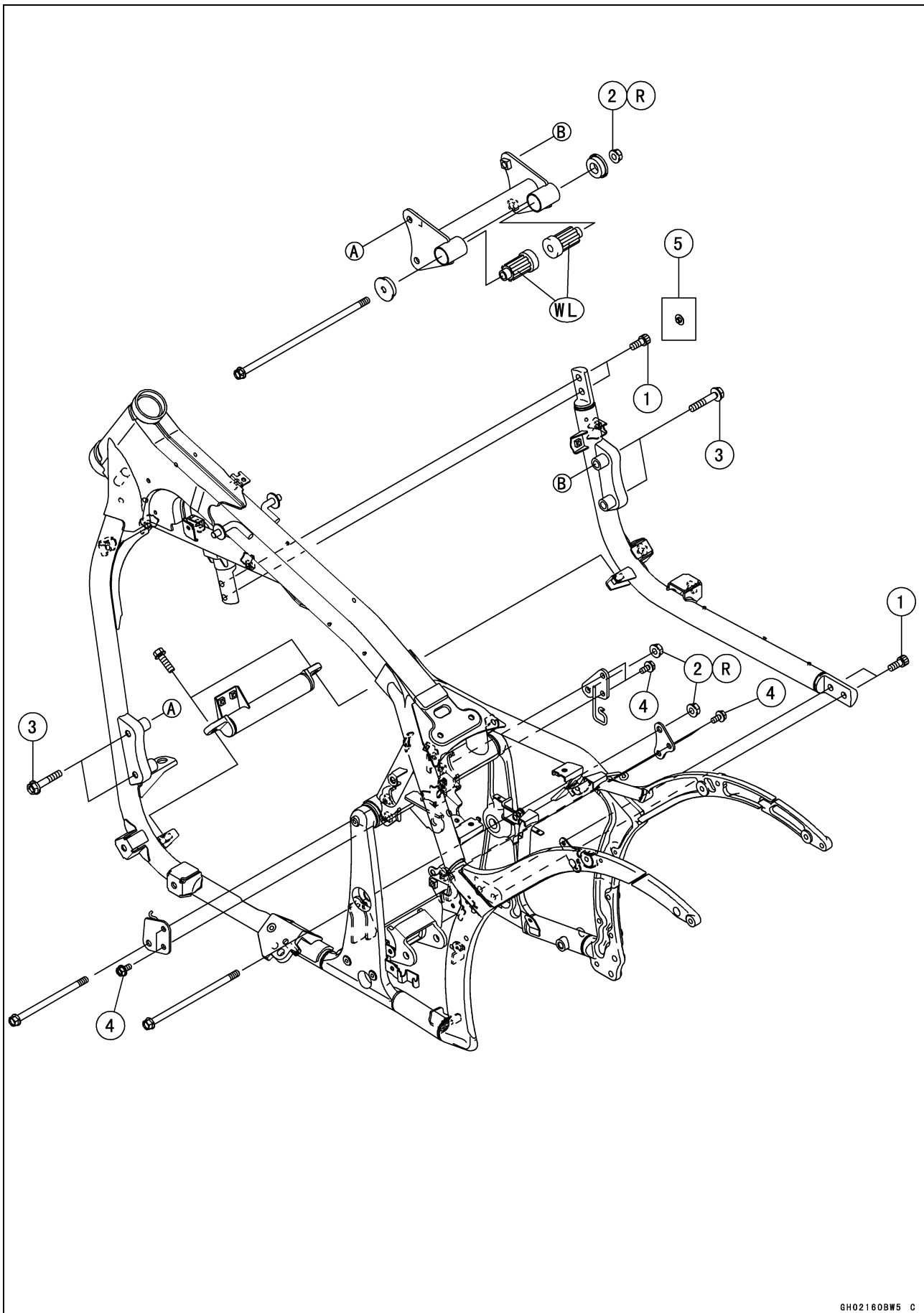

GH021608W5 C

ENGINE REMOVAL/INSTALLATION 8-3

Exploded View

| No. | Fastener | Torque | | | Remarks |
|-----|-------------------------------------|--------|-------|-------|---------|
| | | N·m | kgf·m | ft·lb | |
| 1 | Downtube Bolts | 44 | 4.5 | 32 | |
| 2 | Engine Mounting Nuts | 59 | 6.0 | 44 | R |
| 3 | Engine Mounting Bracket Bolts (M10) | 44 | 4.5 | 32 | |
| 4 | Engine Mounting Bracket Bolts (M8) | 25 | 2.5 | 18 | |

5. VN900C7 ~ C9 Models

WL: Apply a soap and water solution.

R: Replacement Parts

8-4 ENGINE REMOVAL/INSTALLATION

Special Tool

Jack:

57001-1238

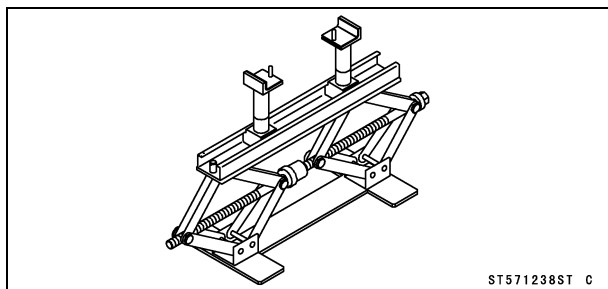

Engine Removal/Installation

Engine Removal

- Drain:
 - Engine Oil (see Engine Oil Change in the Periodic Maintenance chapter)
 - Coolant (see Coolant Change in the Periodic Maintenance chapter)
- Remove:
 - Seat (see Seat Removal in the Frame chapter)
 - Fuel Tank (see Fuel Tank Removal in the Fuel System (DFI) chapter)
 - Mufflers (see Muffler Removal in the Engine Top End chapter)
 - Clutch Cable Lower End (see Clutch Cable Removal in the Clutch chapter)
 - Air Cleaner Housing (see Air Cleaner Housing Removal in the Fuel System (DFI) chapter)
 - Throttle Body Assy (see Throttle Body Assy and Inlet Manifold Removal in the Fuel System (DFI) chapter)
 - Regulator/Rectifier (see Regulator/Rectifier Removal in the Electrical System chapter)
 - Tool Box (see Tool Box Removal in the Frame chapter)
 - Left Side Cover (see Left Side Cover Removal in the Frame chapter)
 - Air Switching Valve (see Air Switching Valve Removal in the Engine Top End chapter)
 - Radiator (see Radiator and Radiator Fan Removal in the Cooling System chapter)
 - Engine Pulley (see Engine Pulley Removal in the Final Drive chapter)
 - Shift Pedal (see Shift Pedal Removal in the Crankshaft/Transmission chapter)
- Remove:
 - Bolts [A]
 - Front Cross Pipe [B]
 - Starter Motor Cable [C]
 - Oil Pressure Switch Lead [D]

- Disconnect the neutral switch terminal [A].

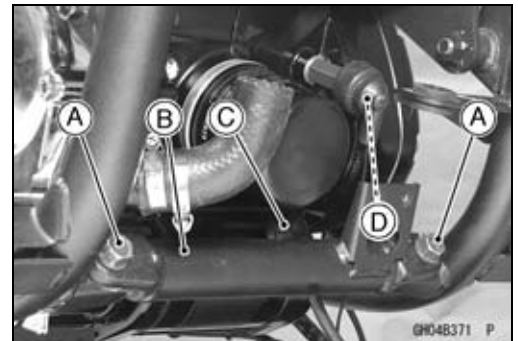

8-6 ENGINE REMOVAL/INSTALLATION

Engine Removal/Installation

- Disconnect the speed sensor lead connector [A].



- Disconnect:
 - Water Temperature Sensor Lead Connector [A]
 - Water Hoses [B]
- Remove the thermostat housing cover bracket bolt [C].

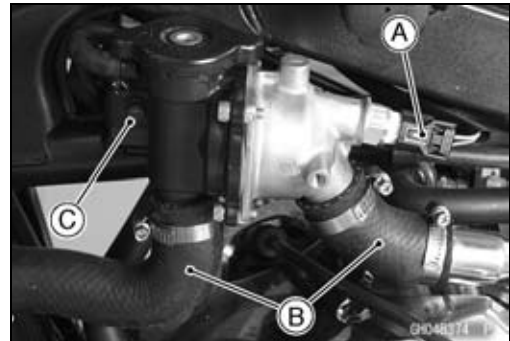

- Remove:
 - Cap [A] and Bolt
 - Ignition Switch [B]

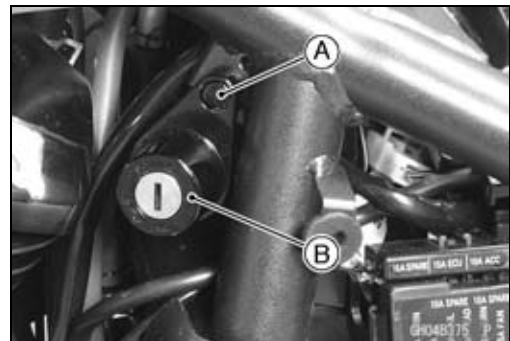

- Disconnect the alternator lead connector [A].

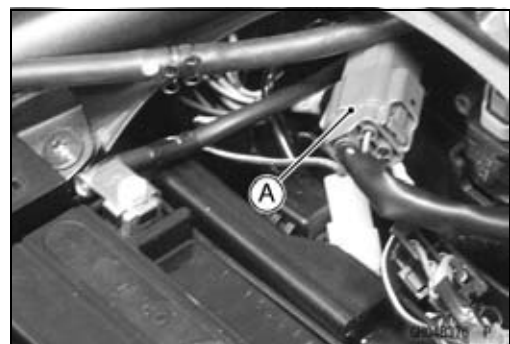

- Remove the engine ground terminal [A].

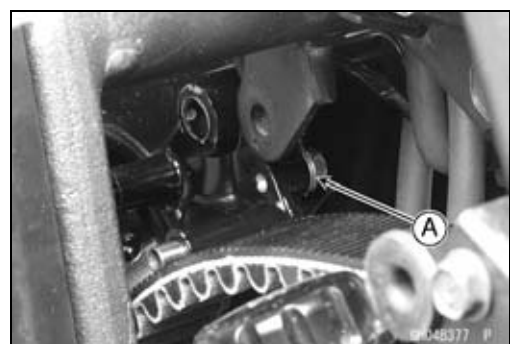

Engine Removal/Installation

- Support the frame with the jack.
Special Tool - Jack: 57001-1238
- Squeeze the brake lever slowly and hold it with a band [A].

⚠ WARNING

Motorcycle may fall over unexpectedly resulting in an accident or injury. Be sure to hold the front brake when removing the engine.

NOTICE

Be sure to hold the front brake when removing the engine, or the motorcycle may fall over. The engine or the motorcycle could be damaged.

- Support the engine with a suitable stand.
- Remove:
 - Downtube [A] (see Downtube Removal in the Frame chapter)
 - Engine Mounting Nuts [B] and Bolts
 - Engine Mounting Bracket Bolts and Brackets [C]
- Using the stand, take out the engine to the right.

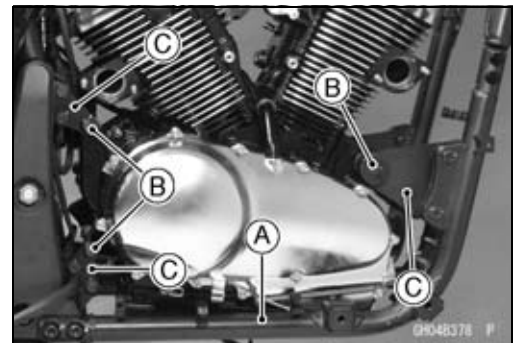
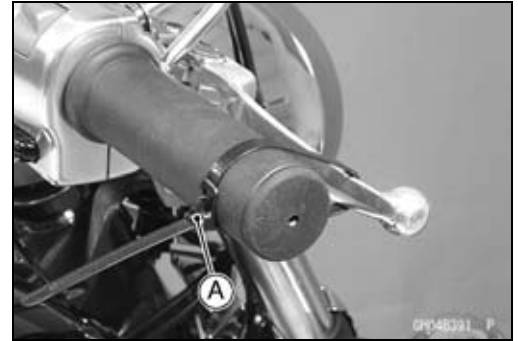

8-8 ENGINE REMOVAL/INSTALLATION

Engine Removal/Installation

Engine Installation

- When installing the rubber dampers into the bracket, lubricate the outer surface of the dampers with a soap and water solution.

| |
|---------------|
| NOTICE |
|---------------|

| |
|---|
| Do not lubricate the rubber damper with engine oil or petroleum distillates because they will deteriorate the rubbers. |
|---|

- Support the engine with a suitable stand.
- Install the engine mounting brackets and downtube.
- Replace the engine mounting nuts with new ones.
- Tighten:
 - Torque - Engine Mounting Bracket Bolts (M8): 25 N·m (2.5 kgf·m, 18 ft·lb)**
 - Engine Mounting Bracket Bolts (M10): 44 N·m (4.5 kgf·m, 32 ft·lb)**
 - Downtube Bolts: 44 N·m (4.5 kgf·m, 32 ft·lb)**
 - Engine Mounting Nuts: 59 N·m (6.0 kgf·m, 44 ft·lb)**
- Run the leads, cables and hoses correctly (see Cable, Wire, and Hose Routing section in the Appendix chapter).
- Install the removed parts (see appropriate chapters).
- Adjust:
 - Throttle Cables (see Throttle Control System Inspection in the Periodic Maintenance chapter)
 - Clutch Cable (see Clutch Operation Inspection in the Periodic Maintenance chapter)
 - Drive Belt (see Belt Deflection Inspection in the Periodic Maintenance chapter)
- Fill the engine with engine oil (see Engine Oil Change in the Periodic Maintenance chapter).
- Fill the engine with coolant and bleed the air from the cooling system (see Coolant Change in the Periodic Maintenance chapter).

Crankshaft/Transmission

Table of Contents

| | |
|--|------|
| Exploded View..... | 9-2 |
| Specifications | 9-6 |
| Special Tools and Sealants | 9-8 |
| Crankcase Splitting..... | 9-9 |
| Crankcase Splitting | 9-9 |
| Crankcase Assembly | 9-10 |
| Crankshaft, Connecting Rods..... | 9-13 |
| Crankshaft Removal | 9-13 |
| Crankshaft Installation | 9-13 |
| Connecting Rod Removal | 9-13 |
| Connecting Rod Installation..... | 9-13 |
| Crankshaft/Connecting Rod Cleaning..... | 9-14 |
| Connecting Rod Bend..... | 9-15 |
| Connecting Rod Twist..... | 9-15 |
| Connecting Rod Big End Bearing Insert/Crankpin Wear | 9-15 |
| Crankshaft Side Clearance Inspection..... | 9-17 |
| Crankshaft Runout Inspection..... | 9-17 |
| Crankshaft Main Bearing/Main Journal Wear Inspection..... | 9-18 |
| Balancer, Starter Motor Clutch | 9-19 |
| Left Balancer Removal..... | 9-19 |
| Left Balancer Installation..... | 9-19 |
| Right Balancer and Starter Motor Clutch Removal..... | 9-19 |
| Right Balancer and Starter Motor Clutch Installation | 9-20 |
| Starter Motor Clutch Inspection | 9-21 |
| Torque Limiter..... | 9-22 |
| Torque Limiter Removal | 9-22 |
| Torque Limiter Inspection..... | 9-22 |
| Primary Gear | 9-23 |
| Primary Gear Removal | 9-23 |
| Primary Gear Installation | 9-23 |
| Transmission | 9-24 |
| Shift Pedal Removal | 9-24 |
| Shift Pedal Installation | 9-24 |
| External Shift Mechanism Removal | 9-25 |
| External Shift Mechanism Installation | 9-25 |
| External Shift Mechanism Inspection..... | 9-26 |
| Transmission Shaft and Shift Fork Removal | 9-26 |
| Transmission Shaft and Shift Fork Installation..... | 9-26 |
| Transmission Shaft Disassembly..... | 9-27 |
| Transmission Shaft Assembly..... | 9-27 |
| Shift Drum Removal..... | 9-30 |
| Shift Drum Installation..... | 9-30 |
| Shift Drum Disassembly..... | 9-30 |
| Shift Drum Assembly | 9-31 |
| Shift Fork Bending | 9-31 |
| Shift Fork/Gear Groove Wear Inspection..... | 9-31 |
| Shift Fork Guide Pin/Drum Groove Wear Inspection | 9-32 |
| Gear Dog and Gear Dog Hole Damage Inspection | 9-32 |
| Ball Bearing and Oil Seal..... | 9-33 |
| Bearing and Oil Seal Installation..... | 9-33 |

9-2 CRANKSHAFT/TRANSMISSION

Exploded View

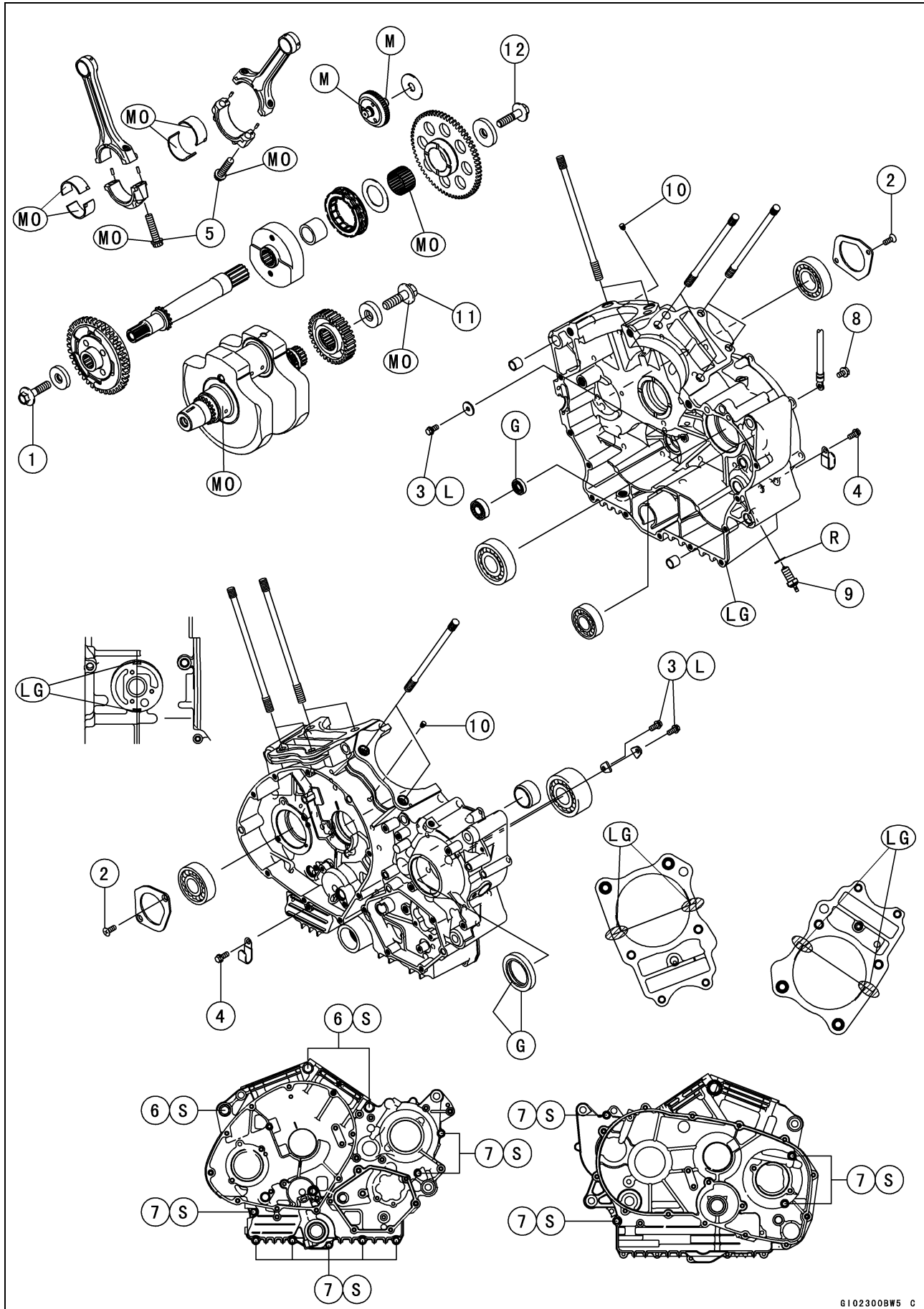

G1023008W5 C

Exploded View

| No. | Fastener | Torque | | | Remarks |
|-----|---|--------|-------|----------|---------|
| | | N·m | kgf·m | ft·lb | |
| 1 | Balancer Gear Bolt | 69 | 7.0 | 51 | |
| 2 | Balancer Shaft Bearing Stopper Plate Screws | 6.9 | 0.70 | 61 in·lb | |
| 3 | Bearing Retainer Bolts | 9.8 | 1.0 | 87 in·lb | L |
| 4 | Clamp Mounting Bolts | 9.8 | 1.0 | 87 in·lb | |
| 5 | Connecting Rod Big End Bolts | 46 | 4.7 | 34 | MO |
| 6 | Crankcase Bolts (M10) | 39 | 4.0 | 29 | S |
| 7 | Crankcase Bolts (M6) | 9.8 | 1.0 | 87 in·lb | S |
| 8 | Engine Ground Lead Bolt | 9.8 | 1.0 | 87 in·lb | |
| 9 | Neutral Switch | 15 | 1.5 | 11 | |
| 10 | Oil Nozzles | 3.9 | 0.40 | 35 in·lb | |
| 11 | Primary Gear Bolt | 98 | 10 | 72 | MO |
| 12 | Starter Motor Clutch Gear Bolt | 69 | 7.0 | 51 | |

G: Apply grease.

L: Apply a non-permanent locking agent.

LG: Apply liquid gasket.

M: Apply molybdenum disulfide grease.

MO: Apply molybdenum disulfide oil solution.

(mixture of the engine oil and molybdenum disulfide grease in a weight ratio 10 : 1)

R: Replacement Parts

S: Follow the specified tightening sequence.

9-4 CRANKSHAFT/TRANSMISSION

Exploded View

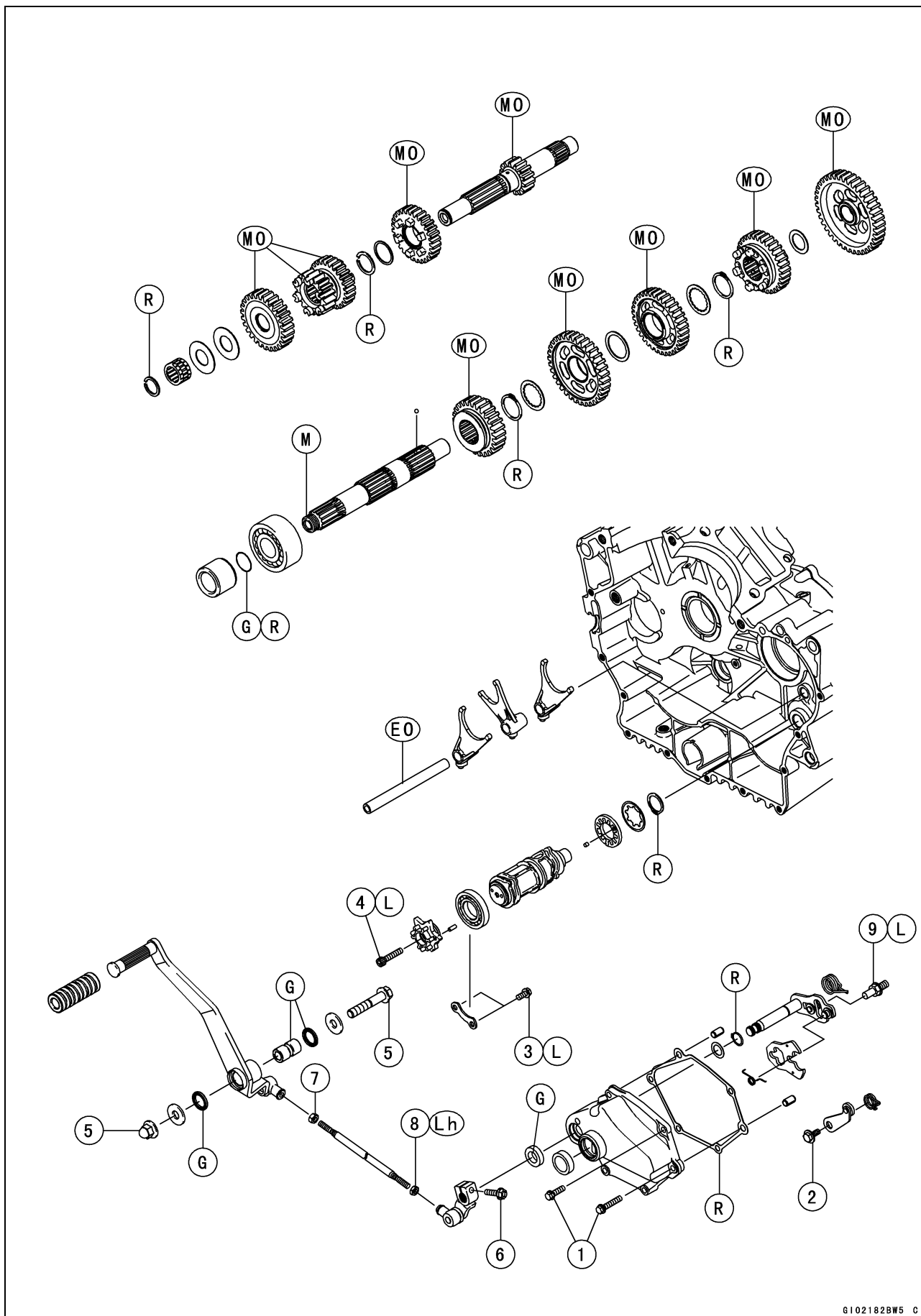

G1021828W5 C

Exploded View

| No. | Fastener | Torque | | | Remarks |
|-----|--------------------------------------|--------|-------|-----------|---------|
| | | N·m | kgf·m | ft·lb | |
| 1 | External Shift Mechanism Cover Bolts | 9.8 | 1.0 | 87 in·lb | |
| 2 | Gear Set Lever Bolt | 9.8 | 1.0 | 87 in·lb | |
| 3 | Shift Drum Bearing Stopper Bolts | 9.8 | 1.0 | 87 in·lb | L |
| 4 | Shift Drum Cam Bolt | 12 | 1.2 | 106 in·lb | L |
| 5 | Shift Pedal Bolt and Nut | 39 | 4.0 | 29 | |
| 6 | Shift Pedal Clamp Bolt | 12 | 1.2 | 106 in·lb | |
| 7 | Shift Rod Locknut (Front) | 9.8 | 1.0 | 87 in·lb | |
| 8 | Shift Rod Locknut (Rear) | 9.8 | 1.0 | 87 in·lb | Lh |
| 9 | Shift Shaft Return Spring Pin | 29 | 3.0 | 21 | L |

EO: Apply engine oil.

G: Apply grease.

L: Apply a non-permanent locking agent.

Lh: Left-hand Threads

M: Apply molybdenum disulfide grease.

MO: Apply molybdenum disulfide oil solution.

(mixture of the engine oil and molybdenum disulfide grease in a weight ratio 10 : 1)

R: Replacement Parts

9-6 CRANKSHAFT/TRANSMISSION

Specifications

| Item | Standard | Service Limit | | | | | | | | | | | | | | | | | | | | | |
|--|---|------------------------------------|-------------|---------------------------------------|---------------------------|----------------|--|------------|-------------|------|---|-------|------------|------|------|-------|------------|---|---|---|------|------|------------|
| Crankshaft, Connecting Rods | | | | | | | | | | | | | | | | | | | | | | | |
| Connecting Rod Bend | — — — | TIR 0.2/100 mm (0.008/3.94 in.) | | | | | | | | | | | | | | | | | | | | | |
| Connecting Rod Twist | — — — | TIR 0.2/100 mm (0.008/3.94 in.) | | | | | | | | | | | | | | | | | | | | | |
| Connecting Rod Big End Side Clearance | 0.08 ~ 0.30 mm (0.003 ~ 0.012 in.) | 0.5 mm (0.02 in.) | | | | | | | | | | | | | | | | | | | | | |
| Connecting Rod Big End Bearing Insert/Crankpin Clearance | 0.026 ~ 0.054 mm (0.0010 ~ 0.0021 in.) | 0.09 mm (0.035 in.) | | | | | | | | | | | | | | | | | | | | | |
| Crankpin Diameter: | 42.984 ~ 43.000 mm (1.6923 ~ 1.6929 in.) | 42.97 mm (1.692 in.) | | | | | | | | | | | | | | | | | | | | | |
| Marking: | | | | | | | | | | | | | | | | | | | | | | | |
| None | 42.984 ~ 42.992 mm (1.6923 ~ 1.6926 in.) | — — — | | | | | | | | | | | | | | | | | | | | | |
| ○ | 42.993 ~ 43.000 mm (1.6926 ~ 1.6929 in.) | — — — | | | | | | | | | | | | | | | | | | | | | |
| Connecting Rod Big End Bore Diameter: | 46.000 ~ 46.016 mm (1.8110 ~ 1.8116 in.) | — — — | | | | | | | | | | | | | | | | | | | | | |
| Marking: | | | | | | | | | | | | | | | | | | | | | | | |
| None | 46.000 ~ 46.008 mm (1.8110 ~ 1.8113 in.) | — — — | | | | | | | | | | | | | | | | | | | | | |
| ○ | 46.009 ~ 46.016 mm (1.8113 ~ 1.8116 in.) | — — — | | | | | | | | | | | | | | | | | | | | | |
| Connecting Rod Big End Bearing Insert Thickness: | | | | | | | | | | | | | | | | | | | | | | | |
| Brown | 1.483 ~ 1.487 mm (0.5838 ~ 0.5854 in.) | — — — | | | | | | | | | | | | | | | | | | | | | |
| Black | 1.487 ~ 1.491 mm (0.5854 ~ 0.5870 in.) | — — — | | | | | | | | | | | | | | | | | | | | | |
| Blue | 1.491 ~ 1.495 mm (0.5870 ~ 0.5886 in.) | — — — | | | | | | | | | | | | | | | | | | | | | |
| Connecting Rod Big End Bearing Insert Selection: | | | | | | | | | | | | | | | | | | | | | | | |
| <table border="1"> <thead> <tr> <th rowspan="2">Con-rod Big End Bore Diameter Marking</th> <th rowspan="2">Crankpin Diameter Marking</th> <th colspan="2">Bearing Insert</th> </tr> <tr> <th>Size Color</th> <th>Part Number</th> </tr> </thead> <tbody> <tr> <td>None</td> <td>○</td> <td>Brown</td> <td>13034-1059</td> </tr> <tr> <td>None</td> <td>None</td> <td rowspan="2">Black</td> <td rowspan="2">13034-1058</td> </tr> <tr> <td>○</td> <td>○</td> </tr> <tr> <td>○</td> <td>None</td> <td>Blue</td> <td>13034-1057</td> </tr> </tbody> </table> | | | | Con-rod Big End Bore Diameter Marking | Crankpin Diameter Marking | Bearing Insert | | Size Color | Part Number | None | ○ | Brown | 13034-1059 | None | None | Black | 13034-1058 | ○ | ○ | ○ | None | Blue | 13034-1057 |
| Con-rod Big End Bore Diameter Marking | Crankpin Diameter Marking | Bearing Insert | | | | | | | | | | | | | | | | | | | | | |
| | | Size Color | Part Number | | | | | | | | | | | | | | | | | | | | |
| None | ○ | Brown | 13034-1059 | | | | | | | | | | | | | | | | | | | | |
| None | None | Black | 13034-1058 | | | | | | | | | | | | | | | | | | | | |
| ○ | ○ | | | | | | | | | | | | | | | | | | | | | | |
| ○ | None | Blue | 13034-1057 | | | | | | | | | | | | | | | | | | | | |
| Crankshaft Side Clearance | 0.05 ~ 0.55 mm (0.002 ~ 0.022 in.) | 0.8 mm (0.03 in.) | | | | | | | | | | | | | | | | | | | | | |
| Crankshaft Web Length | 96.85 ~ 96.95 mm (38.13 ~ 38.17 in.) | 96.6 mm (3.80 in.) | | | | | | | | | | | | | | | | | | | | | |

CRANKSHAFT/TRANSMISSION 9-7

Specifications

| Item | Standard | Service Limit |
|--------------------------------------|---|----------------------------|
| Crankshaft Runout | TIR 0.02 mm (0.0008 in.) or less | TIR 0.05 mm (0.002 in.) |
| Crankshaft Main Journal Diameter | 44.984 ~ 45.000 mm (1.7710 ~ 1.7716 in.) | 44.96 mm (1.770 in.) |
| Crankcase Main Bearing Bore Diameter | 45.025 ~ 45.041 mm (1.7726 ~ 1.7733 in.) | 45.07 mm (1.774 in.) |
| Transmission | | |
| Shift Fork Ear Thickness | 4.9 ~ 5.0 mm (0.193 ~ 0.197 in.) | 4.8 mm (0.189 in.) |
| Gear Groove Width | 5.05 ~ 5.15 mm (0.199 ~ 0.203 in.) | 5.25 mm (0.207 in.) |
| Shift Fork Guide Pin Diameter | 5.9 ~ 6.0 mm (0.232 ~ 0.236 in.) | 5.8 mm (0.228 in.) |
| Shift Drum Groove Width | 6.05 ~ 6.20 mm (0.238 ~ 0.244 in.) | 6.3 mm (0.248 in.) |

TIR: Total Indicator Readings

9-8 CRANKSHAFT/TRANSMISSION

Special Tools and Sealants

Outside Circlip Pliers:

57001-144

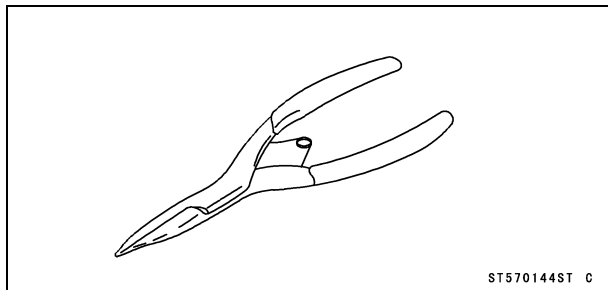

ST570144ST C

Rotor Holder:

57001-1674

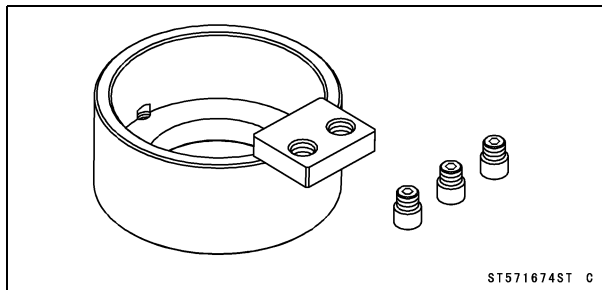

ST571674ST C

Bearing Driver Set:

57001-1129

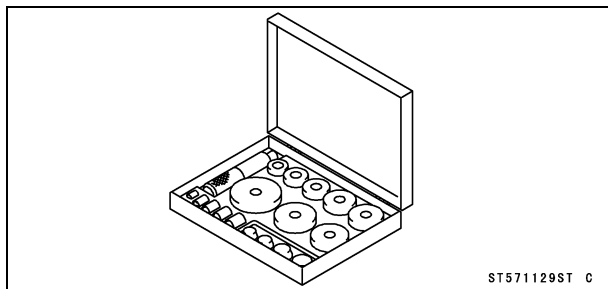

ST571129ST C

Liquid Gasket, TB1211F:

92104-0004

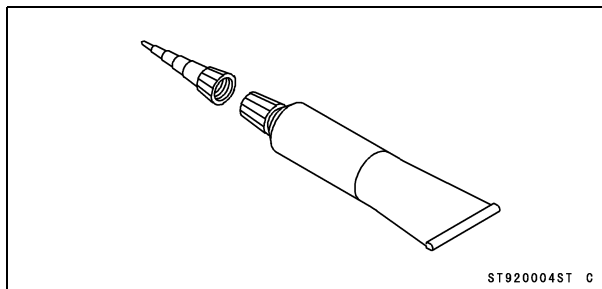

ST920004ST C

Grip:

57001-1591

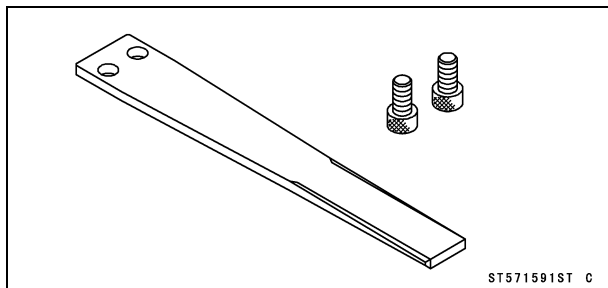

ST571591ST C

Liquid Gasket, TB1216B:

92104-1064

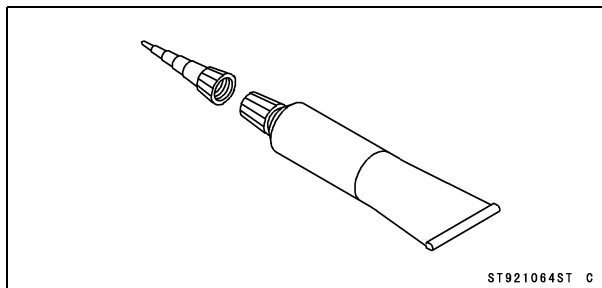

ST921064ST C

Crankcase Splitting

Crankcase Splitting

- Remove:
 - Engine (see Engine Removal in the Engine Removal/Installation chapter)
 - Starter Motor (see Starter Motor Removal in the Electrical System chapter)
 - Oil Filter (see Oil Filter Replacement in the Periodic Maintenance chapter)
 - Plate Bolts [A]
 - Oil Filter Plate [B] and O-rings (2)

- Remove:
 - Clutch (see Clutch Removal in the Clutch chapter)
 - Primary Gear (see Primary Gear Removal)
 - Right Balancer (see Right Balancer and Starter Motor Clutch Removal)
 - Torque Limiter (see Torque Limiter Removal)
 - Water Pump Impeller (see Water Pump Impeller Removal in the Cooling System chapter)
 - Left Balancer (see Left Balancer Removal)
 - Alternator Rotor (see Alternator Rotor Removal in the Electrical System chapter)
 - External Shift Mechanism (see External Shift Mechanism Removal)
 - Cylinders (see Cylinder Removal in the Engine Top End chapter)
 - Pistons (see Piston Removal in the Engine Top End chapter)
 - Bolts [A]
 - Engine Pulley Plate [B]

- Remove the left crankcase bolts in the order listed.
 - M6 Bolts [A]
 - M10 Bolts [B]

- Remove the right crankcase bolts.
 - M6 Bolts [A]

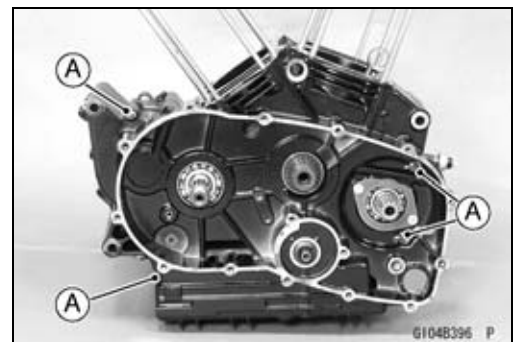
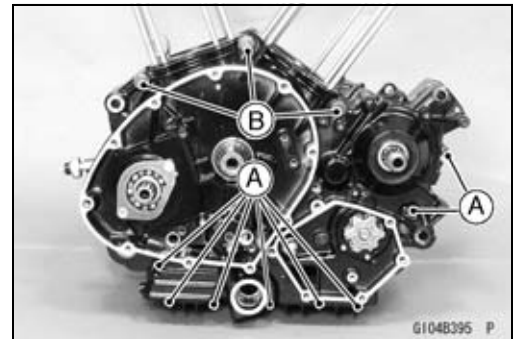
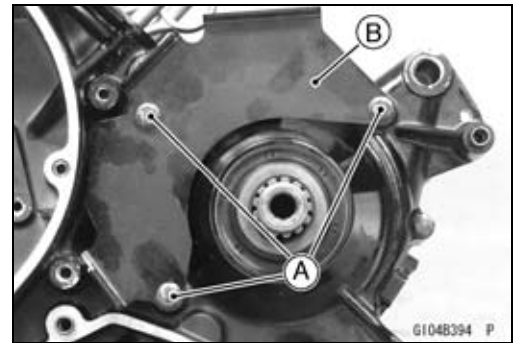
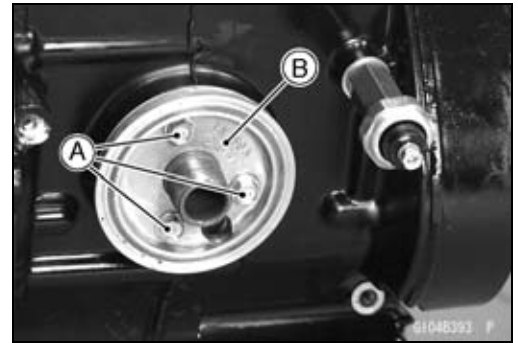

9-10 CRANKSHAFT/TRANSMISSION

Crankcase Splitting

- Put the engine so that the left crankcase is down.
- Pry the points [A] to split the crankcase halves apart, and remove the right crankcase half.
- Tap lightly around the crankcase joint with a plastic mallet, and split the crankcase. Take care not to damage the crankcase.

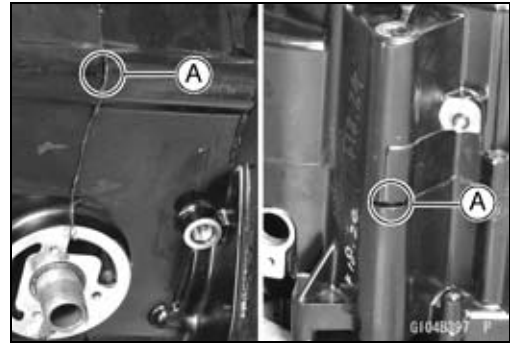

Crankcase Assembly

NOTICE

The right and left crankcase halves are machined at the factory in the assembled state, so the crankcase halves must be replaced as a set.

- With a high flash-point solvent, clean off the mating surfaces of the crankcase halves and wipe dry.
- Using compressed air, blow out the oil passages in the crankcase halves.
- Refer to the Bearing and Oil Seal Installation for the bearing and oil seal installation.
- Check to see that the following parts are in place.

Left Crankcase

- Oil Pipes (Crankcase Inside)
- Oil Return Pipe
- Oil Pump
- Balancer Shaft [A]
- Oil Pump Drive Chain Guide
- Shift Drum
- Transmission Shafts and Gears
- Shift Forks and Shift Rod
- Crankshaft and Connecting Rods
- Oil Filter Adapter Bolt [B]
- Dowel Pins [C]

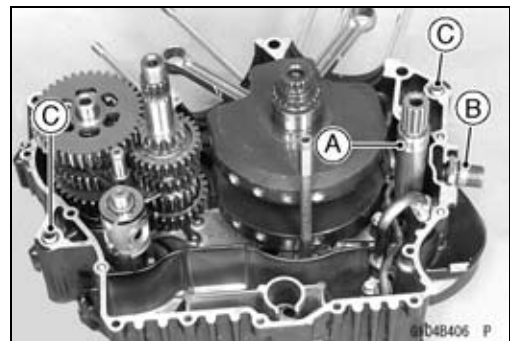

Right Crankcase

- Relief Valve [A]

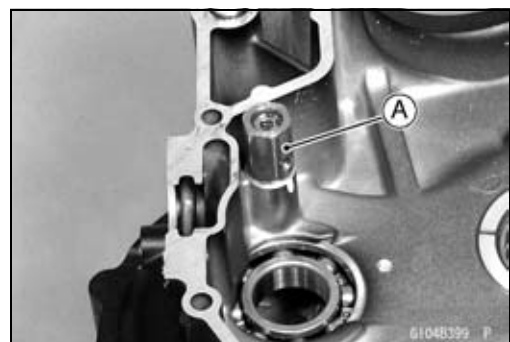

Crankcase Splitting

- Apply liquid gasket [A] to the mating surface of the right crankcase half.

Sealant - Liquid Gasket, TB1216B: 92104-1064

NOTICE

Do not apply liquid gasket to the oil passage [B] and hole [C].

NOTE

- Make the application finish within 20 minutes when the liquid gasket to the mating surface of the right crankcase half is applied.

- Tighten the right crankcase half M6 bolts [A].
Torque - Crankcase Bolts (M6): 9.8 N·m (1.0 kgf·m, 87 in·lb)

- Tighten the left crankcase half M10 bolts [1 ~ 3] to the tightening sequence, and then tighten the M6 bolts [A].
Torque - Crankcase Bolts (M10): 39 N·m (4.0 kgf·m, 29 ft·lb)
Crankcase Bolts (M6): 9.8 N·m (1.0 kgf·m, 87 in·lb)

- Retighten the right crankcase half M6 bolts.
- After tightening all crankcase bolts, check the following items.
 - Seeped out liquid gasket around the mating surface wipe up.
 - Drive shaft and output shaft turn freely.
 - While spinning the output shaft, gears shift smoothly from the 1st to 5th gear, and 5th to 1st.
 - When the output shaft stays still, the gear can not be shifted to 2nd gear or other higher gear positions.

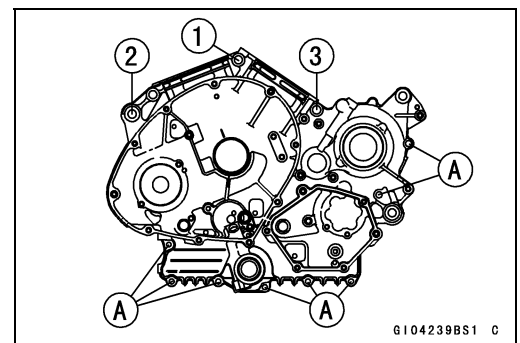
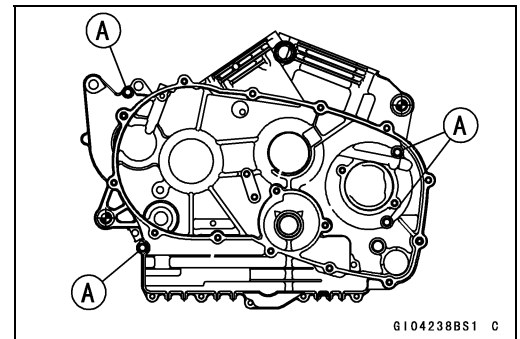
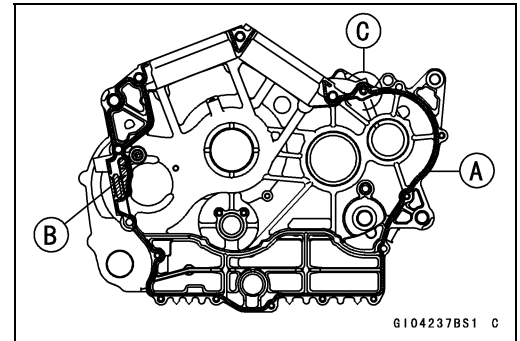

9-12 CRANKSHAFT/TRANSMISSION

Crankcase Splitting

- Apply silicone sealant to the crankcase mating surface [A] as shown in the figure.

Sealant - Liquid Gasket, TB1211F: 92104-0004

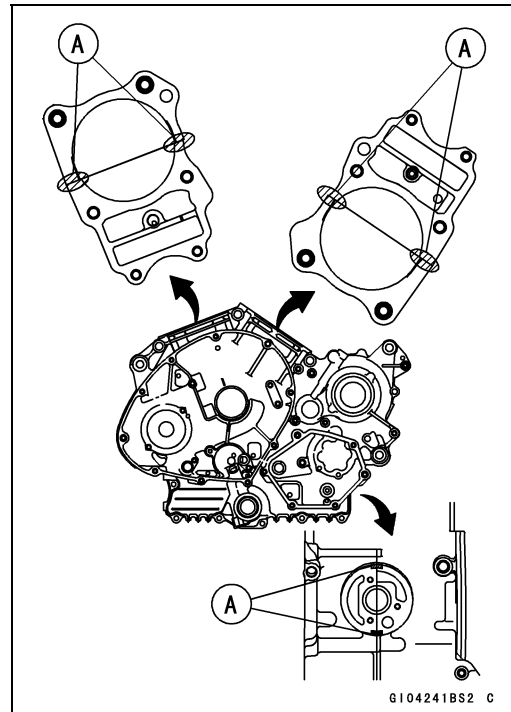

Crankshaft, Connecting Rods

Crankshaft Removal

- Split the crankcase (see Crankcase Splitting).
- Remove the crankshaft.

Crankshaft Installation

- Insert the crankshaft tapered end into the left crankcase [A].
- Install the left connecting rod [B] into the rear cylinder opening [C], and right connecting rod [D] into the front cylinder opening [E].

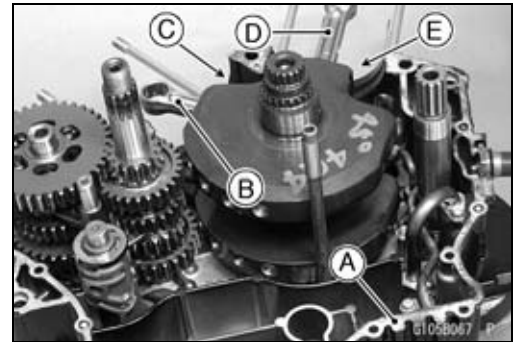

Connecting Rod Removal

- Remove the crankshaft (see Crankshaft Removal).

NOTE

○Mark and record the locations of the connecting rods and their big end caps so that they can be reassembled in their original positions.

- Remove the connecting rod big end cap nuts, and take off the rod and cap with the bearing inserts.

Connecting Rod Installation

NOTICE

To minimize vibration, the connecting rods should have the same weight mark.

- Big End Cap [A]
- Connecting Rod [B]
- Weight Mark, Alphabet [C]
- Diameter Mark (Around Weight Mark) [D]: "O" or no mark.

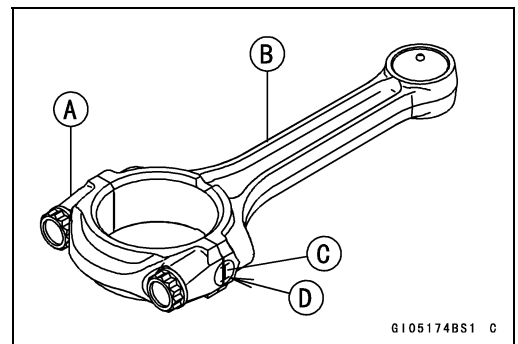

NOTICE

If the connecting rods, big end bearing inserts, or crankshaft are replaced with new ones, select the bearing insert and check clearance with a plasti-gage (press gauge) before assembling engine to be sure the correct bearing inserts are installed.

- Apply molybdenum disulfide oil solution to the inner surface of upper and lower bearing inserts [A].
- Apply a small amount of molybdenum disulfide oil solution to the threads [B] and seating surface [C] of the connecting rod big end bolts.
- If bearing inserts are replaced, install them as follows.
 - Do not apply molybdenum disulfide oil solution to the outside [D] of the inserts or the inside [E] of the connecting rod and cap.
 - Install the inserts so that their nails [F] are on the same side and fit into the recess of the connecting rod and cap.

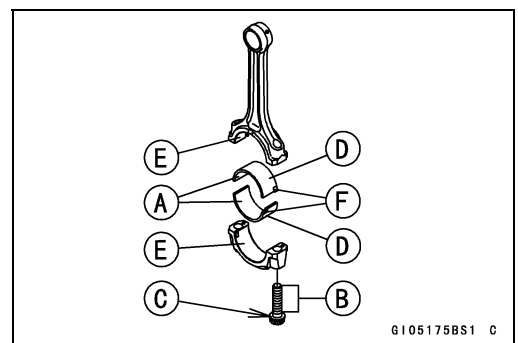

9-14 CRANKSHAFT/TRANSMISSION

Crankshaft, Connecting Rods

○When installing the inserts [A], be careful not to damage the insert surface with the edge of the connecting rod [B] or the cap [C]. One way to install inserts is as follows.

Installation [D] to Cap

Installation [E] to Connecting Rod

Push [F]

Dowel Pin [G]

Connecting Rod Big End Bolts [H]

Suitable Blocks [J]

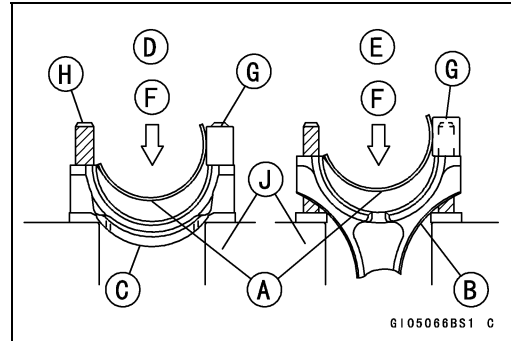

● Be sure the dowel pins [A] on the caps [B] are in position.

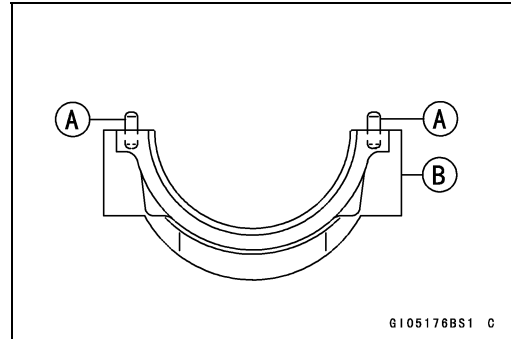

● Install the cap on the connecting rod, aligning the diameter mark.

○Left side connecting rod [A] is for the rear cylinder and right side connecting rod [B] is for the front cylinder.

○Install the connecting rods so that their "embossed" marks [C] face engine right side.

Engine Left Side [D]

Engine Right Side [E]

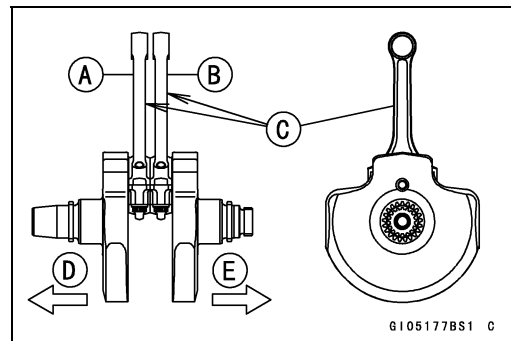

● Remove debris and clean the surface of inserts.

● Tighten:

Torque - Connecting Rod Big End Bolts: 46 N·m (4.7 kgf·m, 34 ft·lb)

Crankshaft/Connecting Rod Cleaning

● After removing the connecting rods from the crankshaft, clean them with a high flash-point solvent.

● Blow the crankshaft oil passages with compressed air to remove any foreign particles or residue that may have accumulated in the passages.

Crankshaft, Connecting Rods

Connecting Rod Bend

- Remove the connecting rod big end bearing inserts, and reinstall the connecting rod big end cap.
- Select an arbor [A] of the same diameter as the connecting rod big end, and insert the arbor through the connecting rod big end.
- Select an arbor of the same diameter as the piston pin and at least 100 mm (3.94 in.) long, and insert the arbor [B] through the connecting rod small end.
- On a surface plate, set the big-end arbor on V block [C].
- With the connecting rod held vertically, use a height gauge to measure the difference in the height of the arbor above the surface plate over a 100 mm (3.94 in.) length to determine the amount of connecting rod bend.
- ★ If connecting rod bend exceeds the service limit, the connecting rod must be replaced.

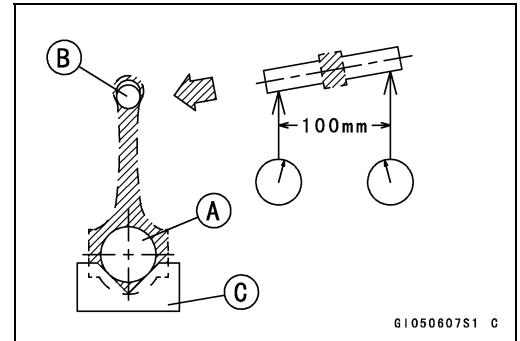

Connecting Rod Bend

Service Limit: TIR 0.2/100 mm (0.008/3.94 in.)

Connecting Rod Twist

- With the big-end arbor [A] still on V block [B], hold the connecting rod horizontally and measure the amount that the arbor [C] varies from being parallel with the surface plate over a 100 mm (3.94 in.) length of the arbor to determine the amount of connecting rod twist.
- ★ If connecting rod twist exceeds the service limit, the connecting rod must be replaced.

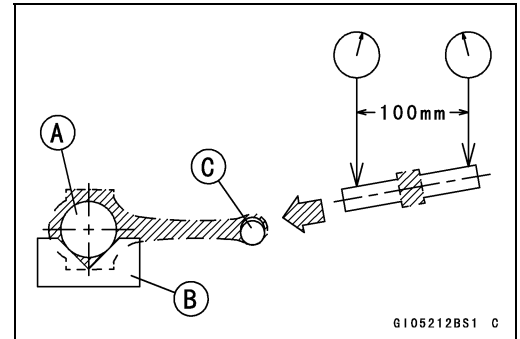

Connecting Rod Twist

Service Limit: TIR 0.2/100 mm (0.008/3.94 in.)

Connecting Rod Big End Bearing Insert/Crankpin Wear

- Measure the bearing insert/crankpin [A] clearance with a plastigage [B].
- Tighten the connecting rod big end bolts to the specified torque (see Connecting Rod Installation).

NOTE

○ Do not move the connecting rod and crankshaft during clearance measurement.

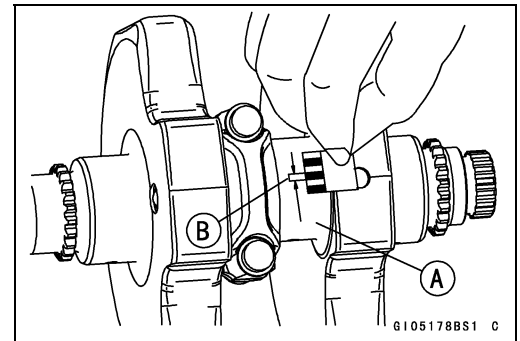

Connecting Rod Big End Bearing Insert/Crankpin Clearance

Standard: 0.026 ~ 0.054 mm (0.0010 ~ 0.0021 in.)

Service Limit: 0.09 mm (0.035 in.)

9-16 CRANKSHAFT/TRANSMISSION

Crankshaft, Connecting Rods

- ★ If clearance is within the standard, no bearing replacement is required.
- ★ If clearance is between 0.054 mm (0.0021 in.) and the service limit (0.09 mm, 0.035 in.), replace the bearing inserts [A] with inserts painted blue [B]. Check insert/crankpin clearance with the plastigage. The clearance may exceed the standard slightly, but it must not be less than the minimum in order to avoid bearing seizure.
- ★ If the clearance exceeds the service limit, measure the diameter of the crankpin.

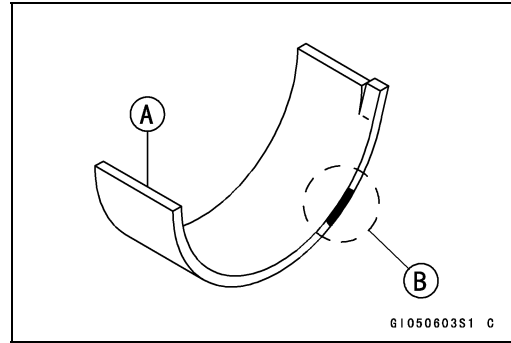

Crankpin Diameter

Standard: 42.984 ~ 43.000 mm (1.6923 ~ 1.6929 in.)

Service Limit: 42.97 mm (1.692 in.)

- ★ If any crankpin has worn past the service limit, replace the crankshaft with a new one.
- ★ If the measured crankpin diameter [A] is not less than the service limit, but do not coincide with the original diameter marking on the crankshaft, make new mark on it.

Crankpin Diameter Mark

None 42.984 ~ 42.992 mm (1.6923 ~ 1.6926 in.)

○ 42.993 ~ 43.000 mm (1.6926 ~ 1.6929 in.)

Crankpin Diameter Mark, "○" mark or no mark [B].

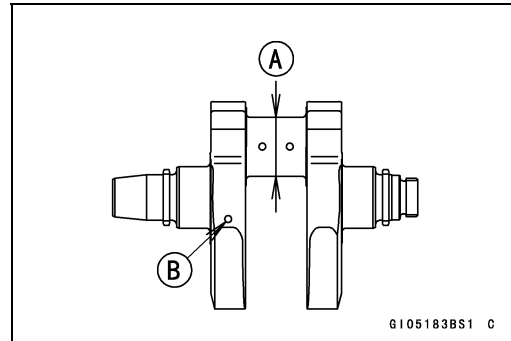

- Measure the connecting rod big end bore diameter, and mark each connecting rod big end in accordance with the bore diameter.
- Tighten the connecting rod big end bolts to the specified torque (see Connecting Rod Installation).

NOTE

○ The mark already on the big end should almost coincide with the measurement because of little wear.

Connecting Rod Big End Bore Diameter Marks

None 46.000 ~ 46.008 mm (1.8110 ~ 1.8113 in.)

○ 46.009 ~ 46.016 mm (1.8113 ~ 1.8116 in.)

Big End Cap [A]

Connecting Rod [B]

Weight Mark, Alphabet [C]

Diameter Mark (Around Weight Mark) [D]: "○" or no mark

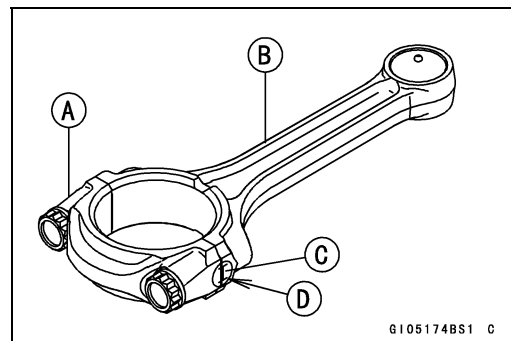

Crankshaft, Connecting Rods

- Select the proper bearing insert [A] in accordance with the combination of the connecting rod and crankshaft coding. Size Color [B]

Connecting Rod Big End Bearing Insert Selection

| Con-rod Big End Bore Diameter Marking | Crankpin Diameter Marking | Bearing Insert | |
|---------------------------------------|---------------------------|----------------|-------------|
| | | Size Color | Part Number |
| None | ○ | Brown | 13034-1059 |
| None | None | Black | 13034-1058 |
| ○ | ○ | | |
| ○ | None | Blue | 13034-1057 |

- Install the new inserts in the connecting rod and check insert/crankpin clearance with the plastigage.

Crankshaft Side Clearance Inspection

- Measure the crankshaft side clearance. Crankshaft [A]
Crankcase [B]
Clearance [C]

Crankshaft Side Clearance

Standard: 0.05 ~ 0.55 mm (0.002 ~ 0.022 in.)

Service Limit: 0.8 mm (0.03 in.)

- ★ If the clearance exceeds the service limit, measure the crankshaft web length [A] to see whether the crankshaft or the crankcase is faulty.

Crankshaft Web Length

Standard: 96.85 ~ 96.95 mm (38.13 ~ 38.17 in.)

Service Limit: 96.6 mm (3.80 in.)

- ★ If the length measurement is smaller than the service limit, replace the crankshaft. Otherwise, replace the crankcase halves as a set.

NOTE

○ The right and left crankcase halves are machined at the factory in the assembled state, so they must be replaced as a set.

Crankshaft Runout Inspection

- Measure the crankshaft runout.
- ★ If the measurement exceeds the service limit, replace the crankshaft.

Crankshaft Runout

Standard: TIR 0.02 mm (0.0008 in.) or less

Service Limit: TIR 0.05 mm (0.002 in.)

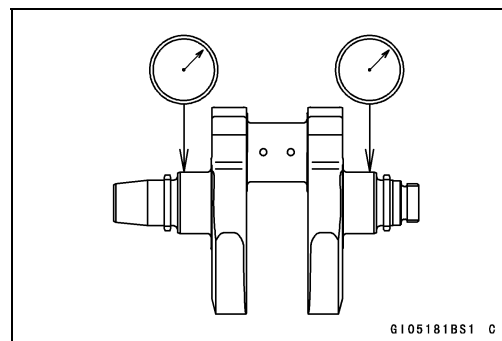
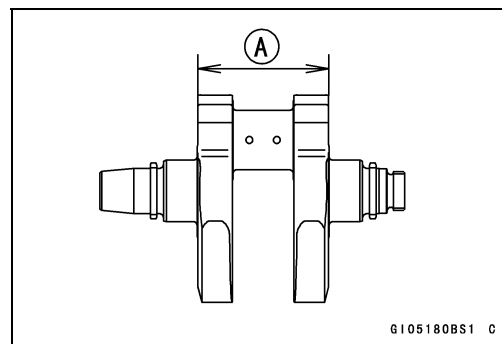
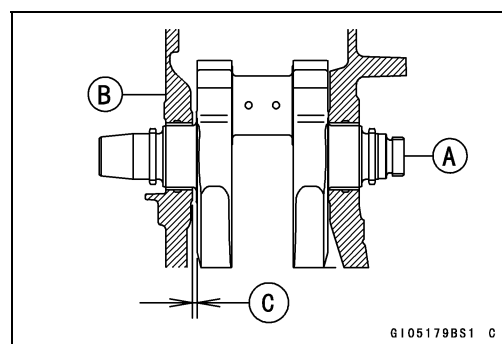
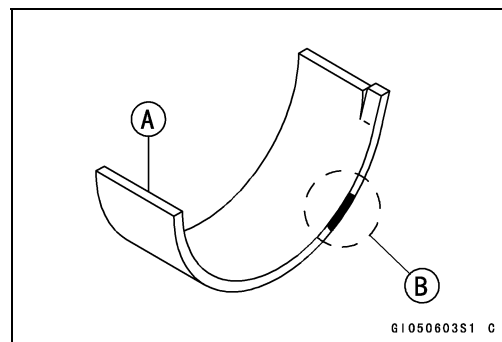

9-18 CRANKSHAFT/TRANSMISSION

Crankshaft, Connecting Rods

Crankshaft Main Bearing/Main Journal Wear Inspection

- Measure the diameter [A] of the crankshaft main journal.
- ★ If any journal has worn past the service limit, replace the crankshaft with a new one.

Crankshaft Main Journal Diameter

Standard: 44.984 ~ 45.000 mm (1.7710 ~ 1.7716 in.)

Service Limit: 44.96 mm (1.770 in.)

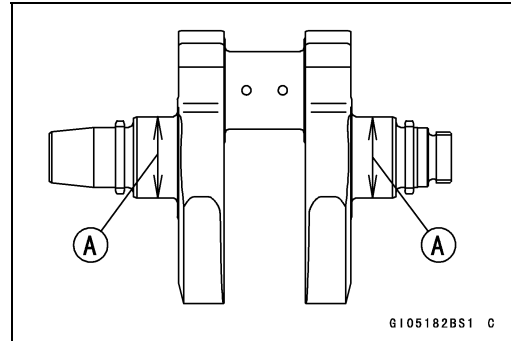

- Measure the main bearing bore diameter [A] in the crankcase halves.

Crankcase Main Bearing Bore Diameter

Standard: 45.025 ~ 45.041 mm (1.7726 ~ 1.7733 in.)

Service Limit: 45.07 mm (1.774 in.)

- ★ If the diameter exceeds the service limit, replace the crankcase halves as a set.

NOTE

- The right and left crankcase halves are machined at the factory in the assembled state, so they must be replaced as a set.

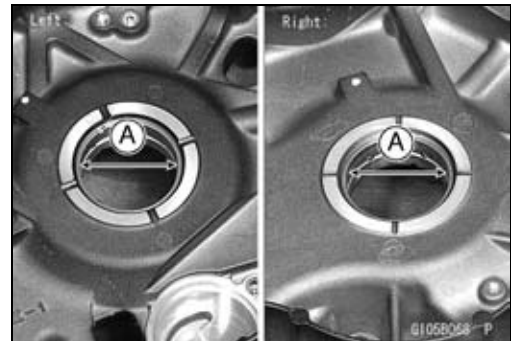

Balancer, Starter Motor Clutch

Left Balancer Removal

- Remove the alternator cover (see Alternator Cover Removal in the Electrical System chapter).
- Wipe oil off the outer circumference of the alternator rotor.
- Hold the alternator rotor steady with the rotor holder [A], and remove the balancer gear bolt [B] and washer [C].
- The rotor holder is prevented from turning by using the suitable M10 bolt [D] and footpeg bracket bolt hole.

Special Tools - Grip [E]: 57001-1591
Rotor Holder: 57001-1674

- Remove:
 - Alternator Rotor (see Alternator Rotor Removal in the Electrical System chapter)
 - Left Balancer Gear
- ★ If the balancer is hard to remove, use a suitable puller.

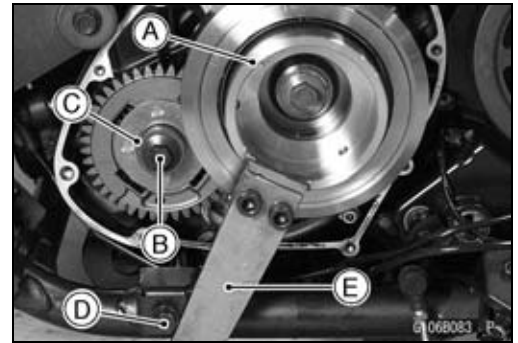

Left Balancer Installation

- Install the balancer gear on the shaft so that the balancer weight punch mark [A] and shaft punch mark [B] align.

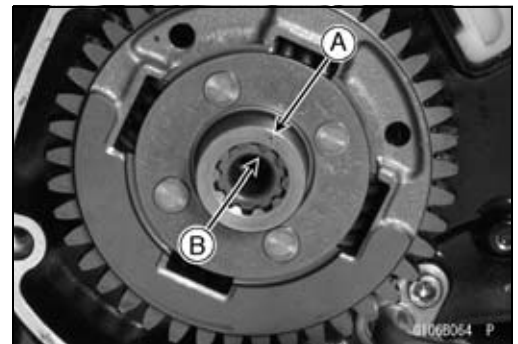

- Install the alternator rotor (see Alternator Rotor Installation in the Electrical System chapter).
- Hold the alternator rotor steady with the rotor holder [A].
- The rotor holder is prevented from turning by using the suitable M10 bolt [B] and footpeg bracket bolt hole.

Special Tools - Grip [C]: 57001-1591
Rotor Holder: 57001-1674

- Tighten:
 - Torque - Balancer Gear Bolt [D]: 69 N·m (7.0 kgf·m, 51 ft·lb)

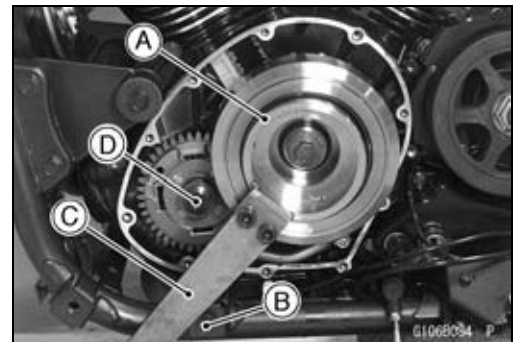

Right Balancer and Starter Motor Clutch Removal

- Remove:
 - Alternator Cover (see Alternator Cover Removal in the Electrical System chapter)
 - Right Engine Cover (see Right Engine Cover Removal in the Clutch chapter)
- Wipe oil off the outer circumference of the alternator rotor.
- Hold the rotor steady with the rotor holder [A].
- The rotor holder is prevented from turning by using the suitable M10 bolt [B] and footpeg bracket bolt hole.

Special Tools - Grip [C]: 57001-1591
Rotor Holder: 57001-1674

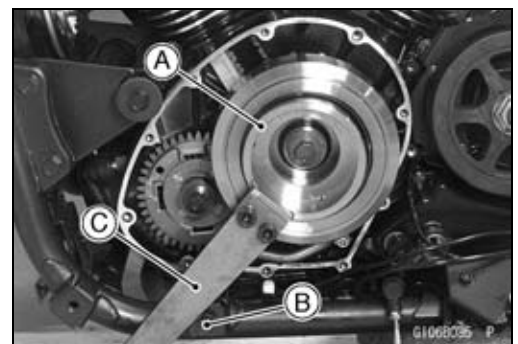

9-20 CRANKSHAFT/TRANSMISSION

Balancer, Starter Motor Clutch

- Remove:
Starter Motor Clutch Gear Bolt [A]
Washers [B]

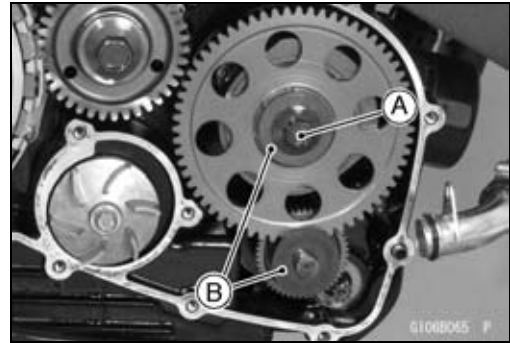

- Remove:
Starter Motor Clutch Gear [A]
Torque Limiter [B]
Needle Bearing [C]
Collar [D]
Starter Motor Clutch Assembly [E]
Washer

★ If the assembly is hard to remove, use a suitable puller.

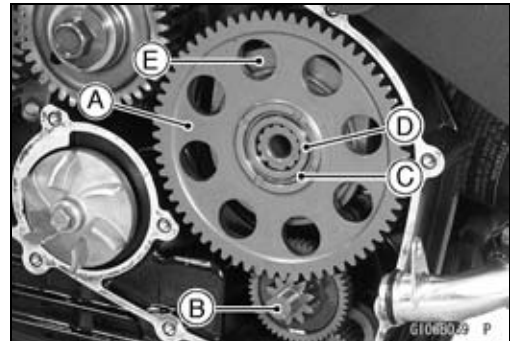

- Separate the starter motor clutch assembly to the right balancer [A] and one-way clutch [B].

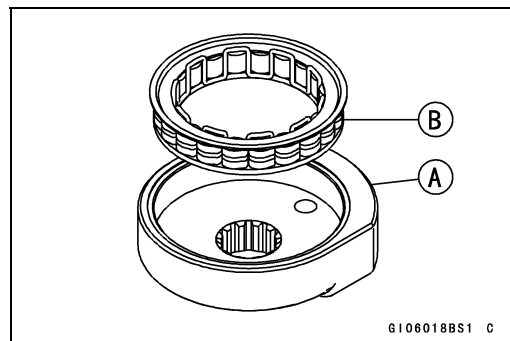

Right Balancer and Starter Motor Clutch Installation

- Be sure to install the one-way clutch [A] so that the flange [B] of it fits in the right balancer recess [C].

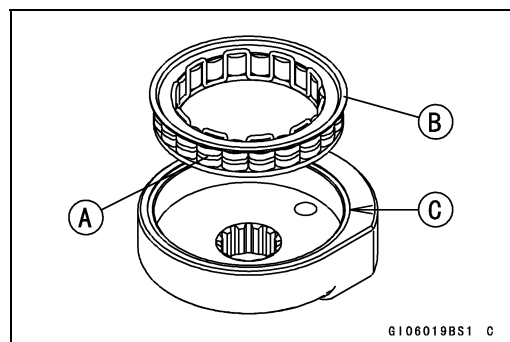

- Clean the starter motor clutch gear bolt and threads in the balancer shaft.
- Install the starter motor clutch assembly on the balancer shaft so that the balancer weight and balancer shaft fit to the tooth laced portions [A].



Balancer, Starter Motor Clutch

- Install:
 - Torque Limiter
 - Washer
 - Collar [A] and Needle Bearing [B]
- Install the starter motor clutch gear [C] while turning [D] the gear.

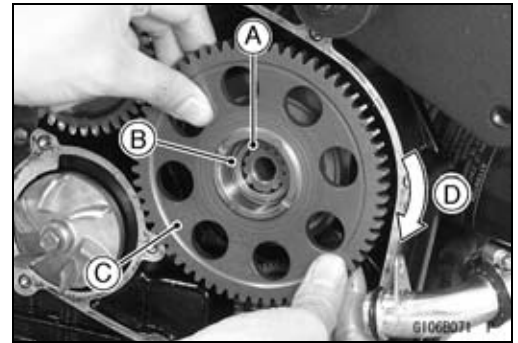

- Install the alternator rotor (see Alternator Rotor Installation in the Electrical System chapter).
- Hold the alternator rotor steady with the rotor holder [A]
- The rotor holder is prevented from turning by using the suitable M10 bolt [B] and footpeg bracket bolt hole.

Special Tools - Grip [C]: 57001-1591
Rotor Holder: 57001-1674

- Tighten:
 - Torque - Starter Motor Clutch Gear Bolt: 69 N·m (7.0 kgf·m, 51 ft·lb)**

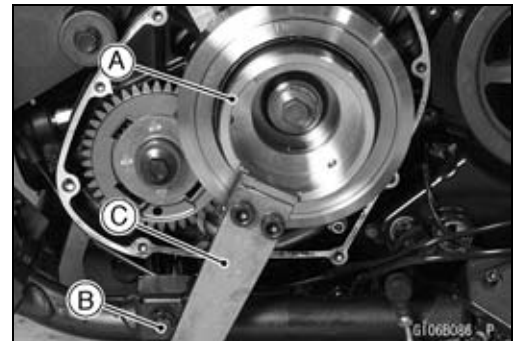

Starter Motor Clutch Inspection

- Drain the engine oil (see Engine Oil Change in the Periodic Maintenance chapter).
- Remove the starter motor (see Starter Motor Removal in the Electrical System chapter).
- Turn the torque limiter gear [A] by hand. When viewed from the left side of the engine, the gear should turn clockwise freely [B], but should not turn counterclockwise.
- ★ If the gear does not operate as it should or if it makes noise, go to the next step.

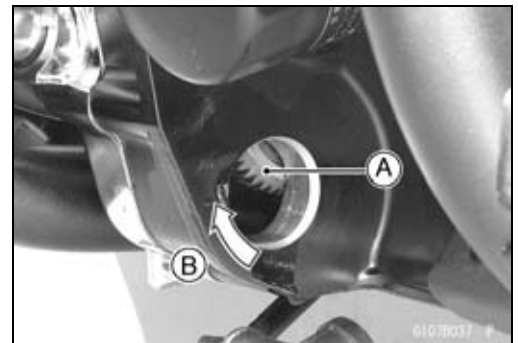

- Disassemble the starter motor clutch (see Right Balancer and Starter Motor Clutch Removal).
- Visually inspect:
 - One-way Clutch [A]
 - Right Balancer [B]
 - Starter Motor Clutch Gear Sliding Surface [C]
- ★ If there is any worn or damaged part, replace it.

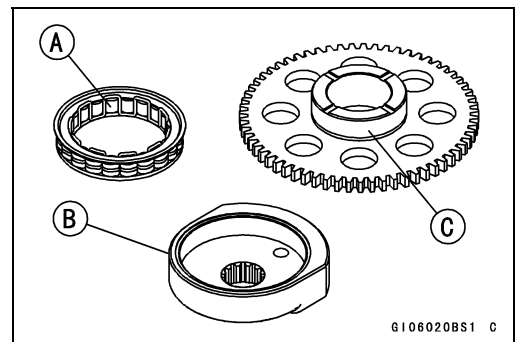

9-22 CRANKSHAFT/TRANSMISSION

Torque Limiter

Torque Limiter Removal

- Remove:
 - Right Engine Cover (see Right Engine Cover Removal in the Clutch chapter)
 - Washer [A]
 - Starter Motor Clutch Gear [B] (see Right Balancer and Starter Motor Clutch Removal)
 - Torque Limiter [C]

NOTICE

Do not disassemble the torque limiter. The torque limiter will not function if this is done.

Torque Limiter Inspection

- Remove the torque limiter and visually inspect it.
- ★ If the limiter has wear, discoloration, or other damage, replace it as a set.
 - Gear [A]
 - Hub [B]
 - Spring [C]
 - Pinion [D]
 - Shim [E]

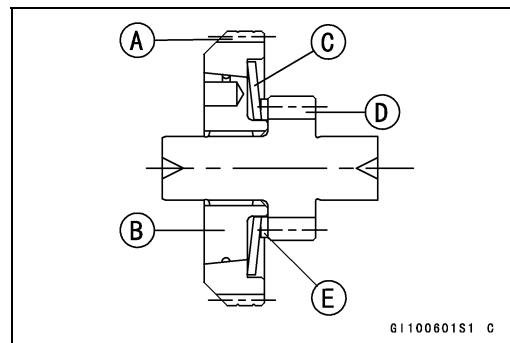
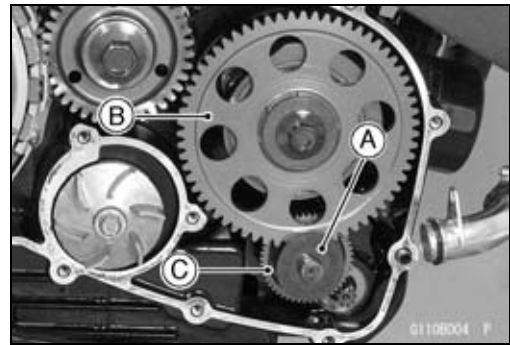

Primary Gear

Primary Gear Removal

- Remove the alternator cover (see Alternator Cover Removal in the Electrical System chapter).
- Wipe oil off the outer circumference of the alternator rotor.
- Hold the alternator rotor steady with the rotor holder [A].
- The rotor holder is prevented from turning by using the suitable M10 bolt [B] and footpeg bracket bolt hole.

Special Tools - Grip [C]: 57001-1591

Rotor Holder: 57001-1674

- Remove the primary gear bolt [A], washer [B] and primary gear [C] from the crankshaft.
- ★ If necessary, remove the clutch (see Clutch Removal in the Clutch chapter).

Primary Gear Installation

- Fit the primary gear [A] with the boss [B] facing toward the engine inside.

- Hold the alternator rotor steady with the rotor holder [A].
- The rotor holder is prevented from turning by using the suitable M10 bolt [B] and footpeg bracket bolt hole.

Special Tools - Grip [C]: 57001-1591

Rotor Holder: 57001-1674

- Apply molybdenum disulfide oil solution to the threads and seating surface of the primary gear bolt, and tighten it.

Torque - Primary Gear Bolt: 98 N·m (10 kgf·m, 72 ft·lb)

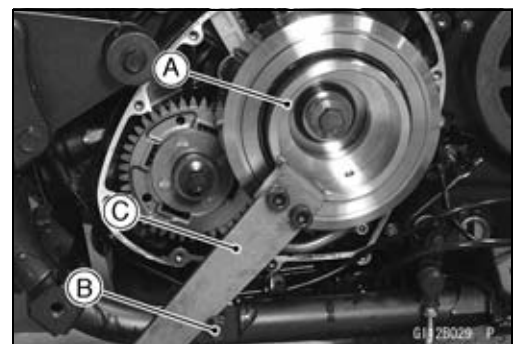
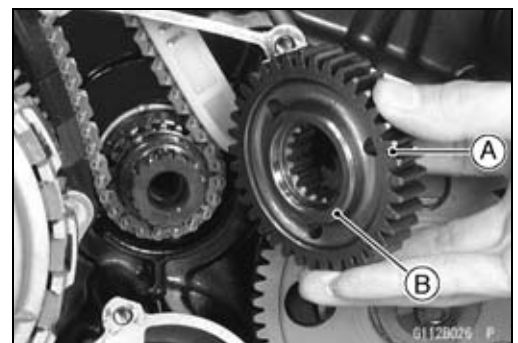
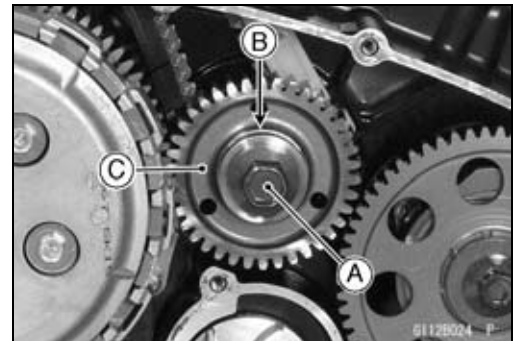
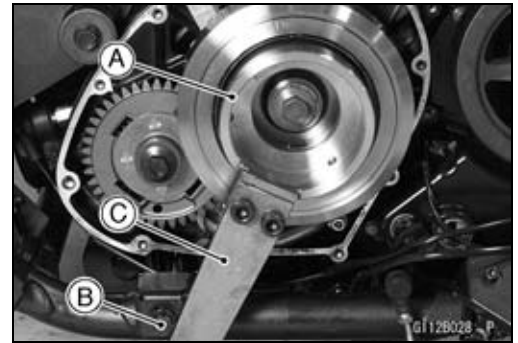

9-24 CRANKSHAFT/TRANSMISSION

Transmission

Shift Pedal Removal

- Remove:
 - Alternator Outer Cover (see Alternator Outer Cover Removal in the Electrical System chapter)
 - Shift Pedal Clamp Bolt [A]

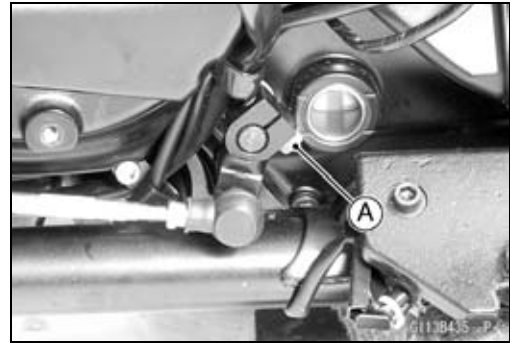

- Remove:
 - Nut [A], Bolt and Washer
 - Shift Pedal [B]

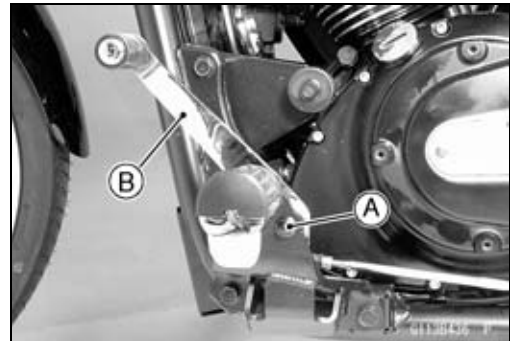

Shift Pedal Installation

- Apply grease to the shift pedal bolt and oil seals.
- Install the oil seals as shown in the figure.
0.4 ~ 1.0 mm (0.016 ~ 0.039 in.) [A]

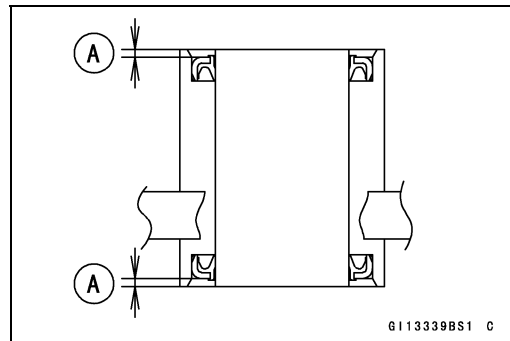

- Install the shift pedal so that the punched mark [A] on the shaft aligned with punched mark [B] on the shift lever.
- Tighten:
 - Torque - Shift Pedal Clamp Bolt: 12 N·m (1.2 kgf·m, 106 in·lb)**

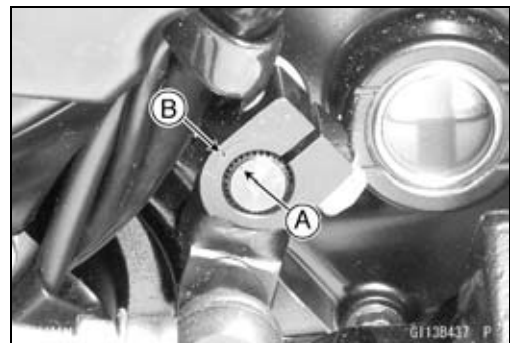

- Install the shift pedal so that the center points [A] [B] [C] straight aligned.
- Tighten:
 - Torque - Shift Pedal Bolt and Nut: 39 N·m (4.0 kgf·m, 29 ft·lb)**

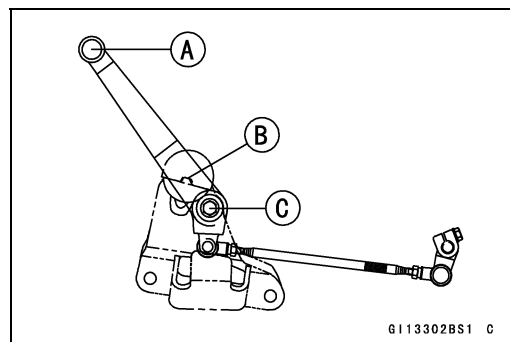

Transmission

- Loosen the locknuts [A] and turn the shift rod [B] so that the outside length [C] of the locknuts is **177 ±1 mm (6.97 ±0.04 in.)**.

○The rear locknut has left-hand threads.

Torque - Shift Rod Locknut (Front): 9.8 N·m (1.0 kgf·m, 87 in·lb)

Shift Rod Locknut (Rear): 9.8 N·m (1.0 kgf·m, 87 in·lb)

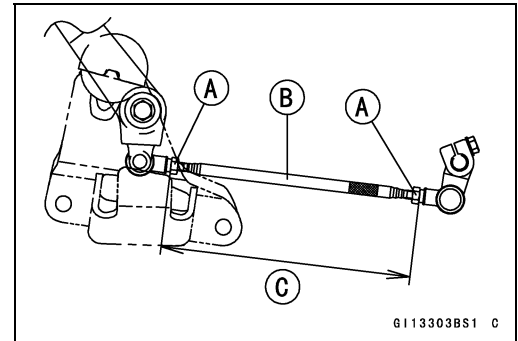

External Shift Mechanism Removal

- Remove:
 - Shift Pedal (see Shift Pedal Removal)
 - Alternator Outer Cover (see Alternator Outer Cover Removal in the Electrical System chapter)
 - Engine Pulley (see Engine Pulley Removal in the Final Drive chapter)
- Pry open the clamp [A].
- Remove:
 - Bolts [B]
 - Engine Pulley Plate [C]
- Remove:
 - Bolts [A]
 - External Shift Mechanism Cover [B] together with the Shift Shaft [C]
- Remove the these bolts [D] with the cover.

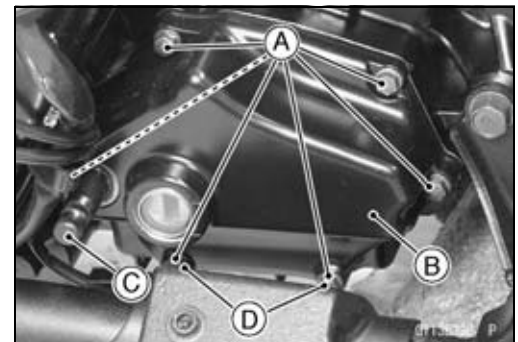
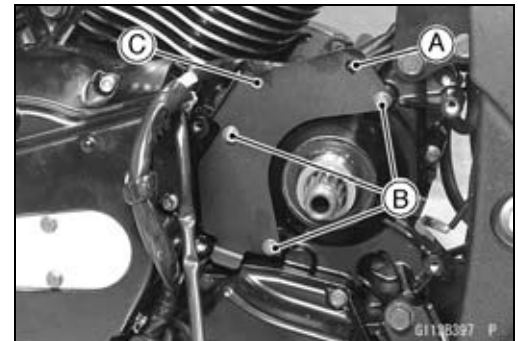

- Remove:
 - Bolt [A]
 - Spring [B]
 - Gear Set Lever [C]

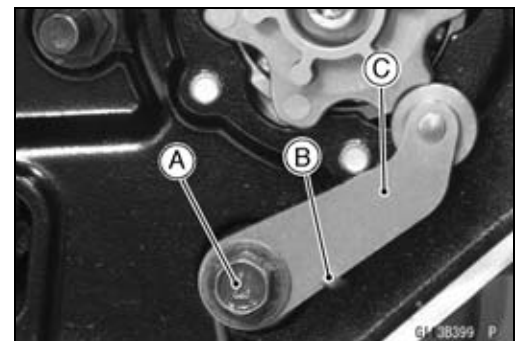

External Shift Mechanism Installation

- Install the gear set lever [A] and spring [B], and tighten the bolt [C].
- Torque - Gear Set Lever Bolt: 9.8 N·m (1.0 kgf·m, 87 in·lb)**
- Install the dowel pins [D] and new cover gasket.
- Apply grease to the oil seal lip.
- Install the washer to the shift shaft, then insert the shaft into the cover.

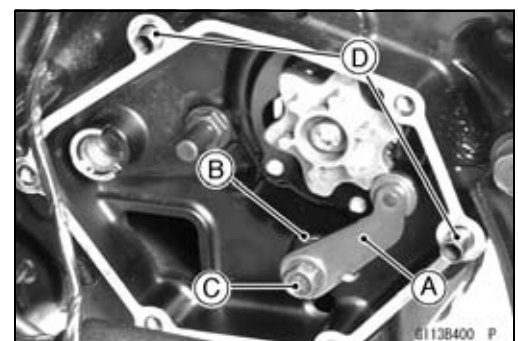

9-26 CRANKSHAFT/TRANSMISSION

Transmission

- Set the these cover bolts [A] to the cover before cover installed.
- Install the cover with the shaft to the crankcase.
- Tighten:
Torque - External Shift Mechanism Cover Bolts: 9.8 N·m (1.0 kgf·m, 87 in·lb)

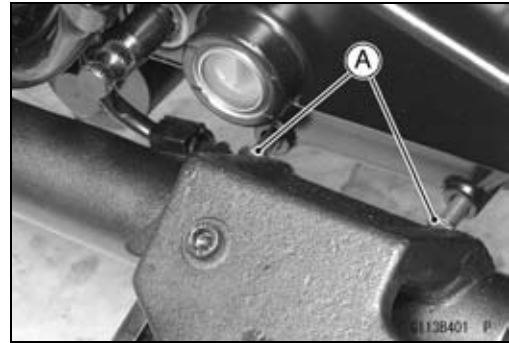

External Shift Mechanism Inspection

- Examine the shift shaft [A] for any damage.
- ★ If the shaft is bent, straighten or replace it.
- ★ If the splines [B] are damaged, replace the shaft.
- ★ If the springs [C] are damaged in any way, replace them.
- ★ If the shift mechanism arm [D] is damaged in any way, replace it.

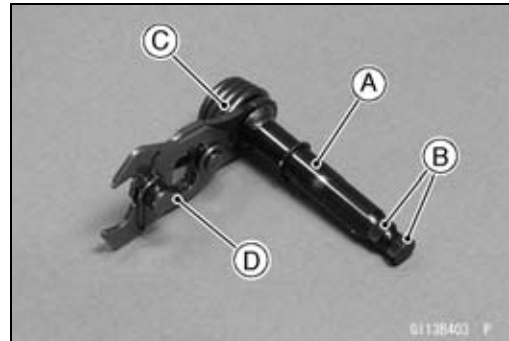

- Check the return spring pin [A] is not loose.
- ★ If it is loose, unscrew it, apply a non-permanent locking agent to the threads, and tighten it.

Torque - Shift Shaft Return Spring Pin: 29 N·m (3.0 kgf·m, 21 ft·lb)

- Check the gear set lever [B] and spring [C] for breaks or distortion.
- ★ If the lever or spring is damaged in any way, replace it.
- Visually inspect the shift drum cam [D].
- ★ If it is badly worn or shows any damage, replace it.

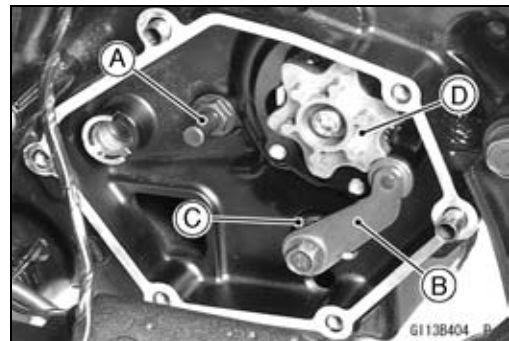

Transmission Shaft and Shift Fork Removal

- Split the crankcase (see Crankcase Splitting).
- Remove:
 - Shift Rod [A]
 - Shift Forks [B]
- Take out the drive shaft [C] and output shaft [D] as a set.

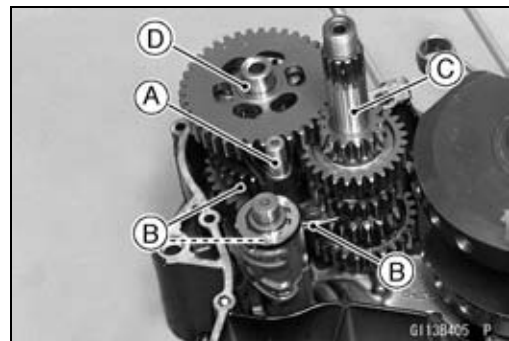

Transmission Shaft and Shift Fork Installation

- Apply engine oil to the transmission shafts and shift forks.
- Install the drive shaft and output shaft as a set.
- Install the shift forks [A] [B] so that the marks (031) [C] on the shift fork for output shaft face the upward.
- The two forks on the output shaft are identical.

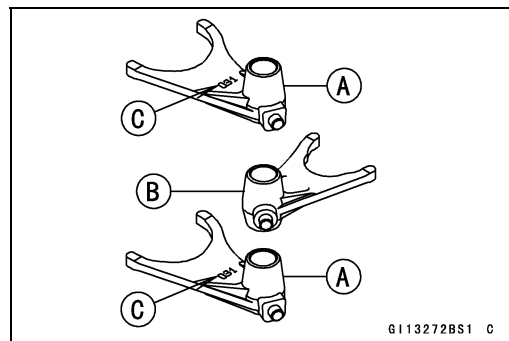

Transmission

- Install the shift drum [A].
- Set the shift drum in the neutral position.
- Apply engine oil to the shift rod [B], and install it.

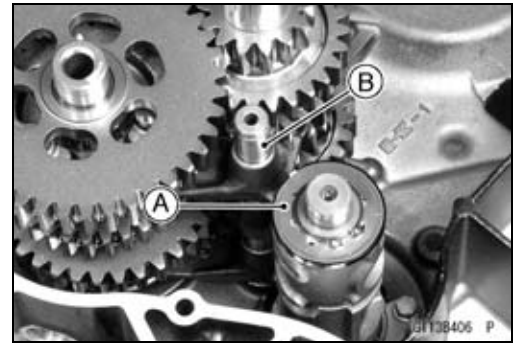

Transmission Shaft Disassembly

- Remove the transmission shafts (see Transmission Shaft and Shift Fork Removal).
- Remove the circlips, disassemble the transmission shafts.

Special Tool - Outside Circlip Pliers: 57001-144

- The 4th gear [A] on the output shaft has three steel balls for the positive neutral finder mechanism.
- Remove the 4th gear as follows.
 - Set the output shaft in a vertical position holding the 3rd gear [B].
 - Spin the 4th gear quickly [C] and pull it off upward.

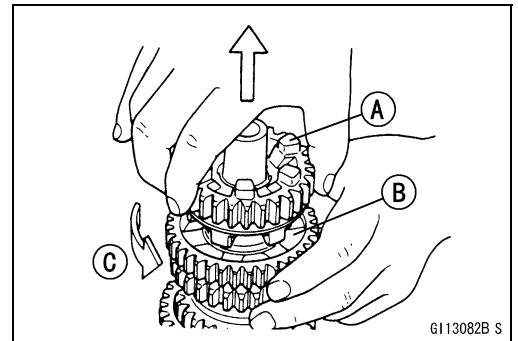

Transmission Shaft Assembly

- Install the 5th gear [A] on the output shaft with its oil hole [B] aligned with the shaft oil hole [C].

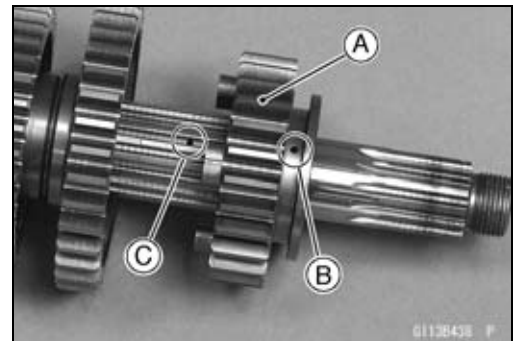

- Fit the steel balls into the 4th gear holes as shown in the figure.

(This illustration shows "section A-A" in the transmission assembly figure. Page 9-29)

- Gear (4th) [A]
- Shaft [B]
- Steel Balls [C]
- Oil Holes [D]

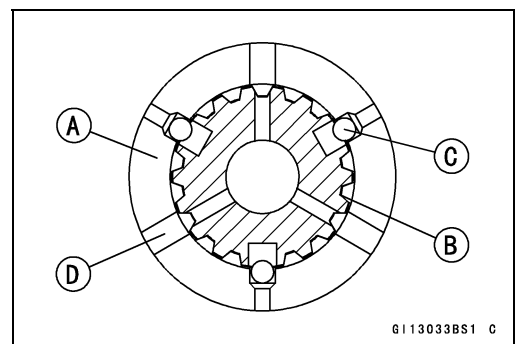

NOTICE

Do not apply grease to the steel balls to hold them in place. This will cause the positive neutral finder mechanism to malfunction.

9-28 CRANKSHAFT/TRANSMISSION

Transmission

- Replace any circlip that were removed with new ones.
- Install the circlips [A] so that the opening [B] is aligned with a spline groove [C].
- Check that each gear springs or slides freely on the transmission shaft without binding after assembly.

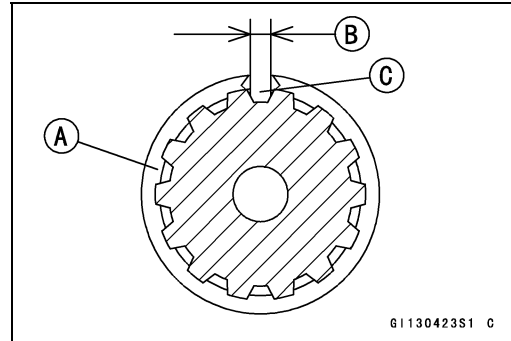

Transmission

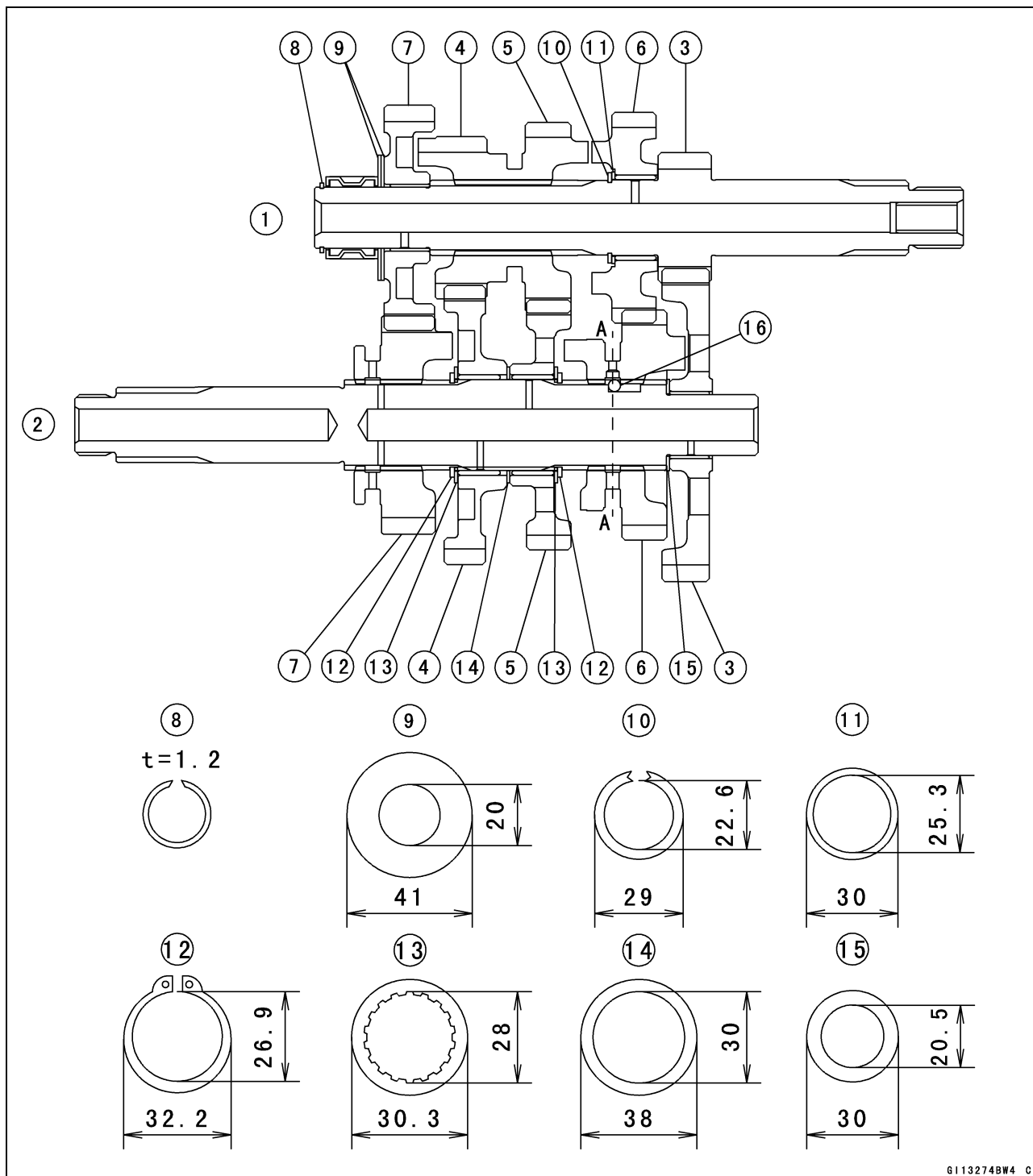

- 1. Drive Shaft
- 2. Output Shaft
- 3. 1st Gear
- 4. 2nd Gear
- 5. 3rd Gear
- 6. 4th Gear
- 7. 5th (Top) Gear
- 8. Circlip

- 9. Thrust Washer (20 × 41 × 1)
- 10. Circlip
- 11. Thrust Washer (25.3 × 30 × 1)
- 12. Circlip
- 13. Toothed Washer
- 14. Thrust Washer (30 × 38 × 1)
- 15. Thrust Washer (20.5 × 30 × 1)
- 16. Steel Ball

9-30 CRANKSHAFT/TRANSMISSION

Transmission

Shift Drum Removal

- Remove:
 - Transmission Shafts (see Transmission Shaft and Shift Fork Removal)
 - Bolts [A]
 - Bearing Stopper [B]
- While aligning the shift drum cam with the left crankcase hole, pull out the shift drum [C].

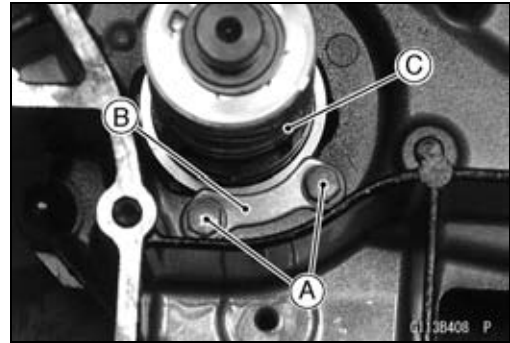

Shift Drum Installation

- While aligning the shift drum cam [A] with the left crankcase hole, install the shift drum.
 - Apply a non-permanent locking agent to the threads of the bolts, and tighten them.
- Torque - Shift Drum Bearing Stopper Bolts: 9.8 N·m (1.0 kgf·m, 87 in·lb)**



Shift Drum Disassembly

- Remove the shift drum (see Shift Drum Removal).
 - While holding the shift drum with a vise, remove the shift drum cam bolt [A].
 - Shift Drum Cam [B]
 - Dowel Pin (Longer) [C]
 - Remove the circlip [D].
- Special Tool - Outside Circlip Pliers: 57001-144**
- Remove:
 - Spring [E]
 - Shift Drum Holder [F]
 - Dowel Pin (Shorter) [G]

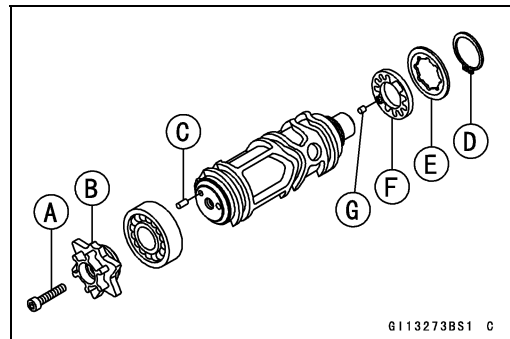

Transmission

Shift Drum Assembly

- Assemble:
 - Dowel Pin (Shorter) [A]
 - Shift Drum Holder [B]
 - Spring [C]
 - Circlip [D]

Special Tool - Outside Circlip Pliers: 57001-144

- Assemble:
 - Dowel Pin (Longer) [E]
 - Bearing [F]
 - Shift Drum Cam [G]
 - Shift Drum [H]
- Apply a non-permanent locking agent to the threads of the shift drum cam bolt [I], and tighten it.

Torque - Shift Drum Cam Bolt: 12 N·m (1.2 kgf·m, 106 in·lb)

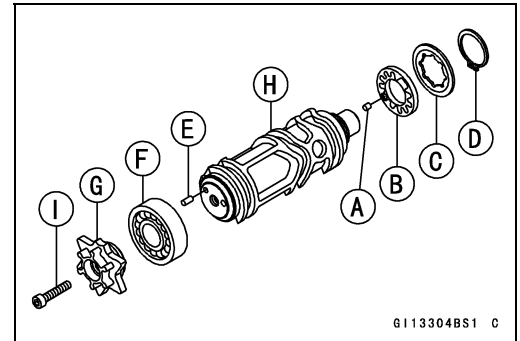

G113304BS1 C

Shift Fork Bending

- Visually inspect the shift forks, and replace any fork that is bent. A bent fork could cause difficulty in shifting, or allow the transmission to jump out of gear when under power. 90° [A]

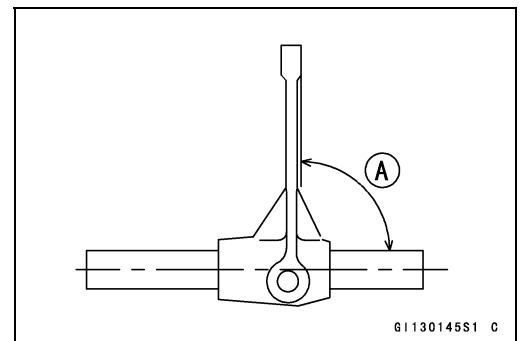

G1130145S1 C

Shift Fork/Gear Groove Wear Inspection

- Measure the thickness of the shift fork ears [A], and measure the width [B] of the gear grooves.
- ★ If the thickness of a shift fork ear is less than the service limit, the shift fork must be replaced.

Shift Fork Ear Thickness

- Standard:** 4.9 ~ 5.0 mm (0.193 ~ 0.197 in.)
- Service Limit:** 4.8 mm (0.189 in.)

- ★ If the gear groove is worn over the service limit, the gear must be replaced.

Gear Groove Width

- Standard:** 5.05 ~ 5.15 mm (0.199 ~ 0.203 in.)
- Service Limit:** 5.25 mm (0.207 in.)

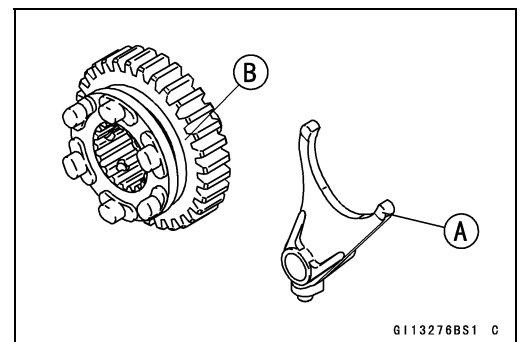

G113276BS1 C

9-32 CRANKSHAFT/TRANSMISSION

Transmission

Shift Fork Guide Pin/Drum Groove Wear Inspection

- Measure the diameter of each shift fork guide pin [A], and measure the width [B] of each shift drum groove.
- ★ If the guide pin on any shift fork is less than the service limit, the fork must be replaced.

Shift Fork Guide Pin Diameter

Standard: 5.9 ~ 6.0 mm (0.232 ~ 0.236 in.)

Service Limit: 5.8 mm (0.228 in.)

- ★ If any shift drum groove is worn over the service limit, the drum must be replaced.

Shift Drum Groove Width

Standard: 6.05 ~ 6.20 mm (0.238 ~ 0.244 in.)

Service Limit: 6.3 mm (0.248 in.)

Gear Dog and Gear Dog Hole Damage Inspection

- Visually inspect the gear dogs [A] and gear dog holes [B].
- ★ Replace any damaged gears or gears with excessively worn dogs or dog holes.

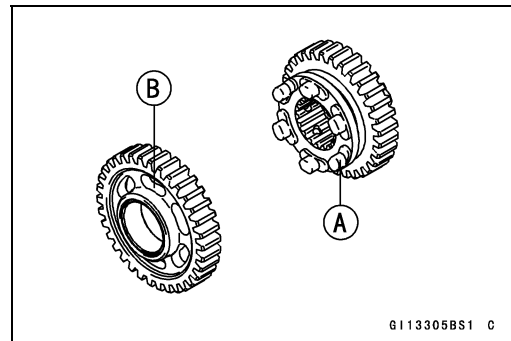
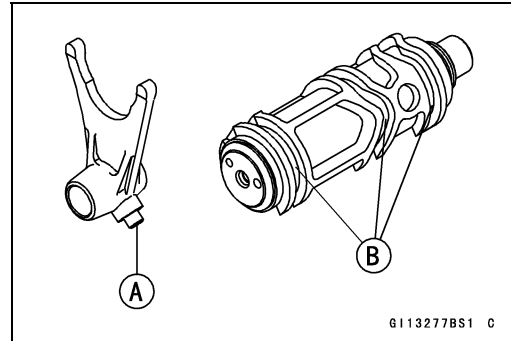

Ball Bearing and Oil Seal

Bearing and Oil Seal Installation

- When installing a bearing other than the following parts, press it in with the marked side facing out.

Special Tool - Bearing Driver Set: 57001-1129

Right Crankcase

- Press the water pump shaft bearing and oil seal as shown in the figure.

Oil Seal [A]

Marked Side [B]

Ball Bearing [C]

Mechanical Seal [D] (see Mechanical Seal Replacement in the Cooling System chapter)

Special Tool - Bearing Driver Set: 57001-1129

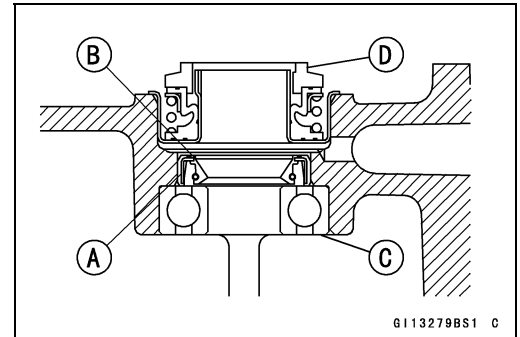

- Press the output shaft bearing [A] into the right crankcase [B] with the sealed side [C] facing the crankcase.

Special Tool - Bearing Driver Set: 57001-1129

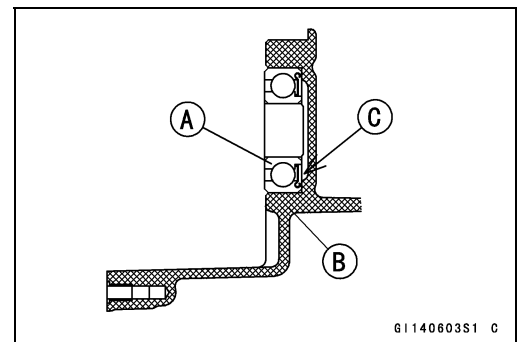

Left Crankcase

- Press the output shaft oil seal [A] so that the oil seal lip [B] facing outside, and oil seal surface flush with the left crankcase surface [C].

Special Tool - Bearing Driver Set: 57001-1129

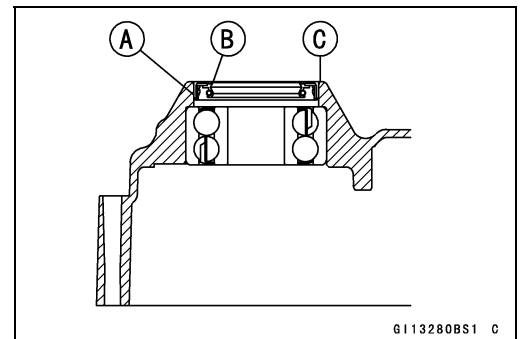

- Press the input shaft bushing [A] so that the chamfered side [B] facing inside, and bushing surface flush with the left crankcase surface [C].

Special Tool - Bearing Driver Set: 57001-1129

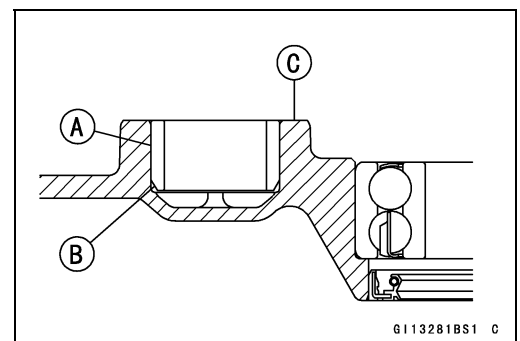

Wheels/Tires

Table of Contents

| | |
|--|-------|
| Exploded View | 10-2 |
| Specifications | 10-4 |
| Special Tools | 10-5 |
| Wheels (Rims) | 10-6 |
| Front Wheel Removal | 10-6 |
| Front Wheel Installation | 10-7 |
| Rear Wheel Removal | 10-7 |
| Rear Wheel Installation | 10-9 |
| Wheel Inspection | 10-11 |
| Axle Inspection | 10-11 |
| Balance Inspection | 10-12 |
| Balance Adjustment | 10-12 |
| Balance Weight Removal | 10-12 |
| Balance Weight Installation | 10-13 |
| Tires | 10-16 |
| Air Pressure Inspection/Adjustment | 10-16 |
| Tire Inspection | 10-16 |
| Tire Removal | 10-16 |
| Tire Installation | 10-16 |
| Tire Repair | 10-18 |
| Hub Bearing | 10-19 |
| Hub Bearing Removal | 10-19 |
| Hub Bearing Installation | 10-19 |
| Hub Bearing Inspection | 10-20 |
| Hub Bearing Lubrication | 10-20 |

10-2 WHEELS/TIRES

Exploded View

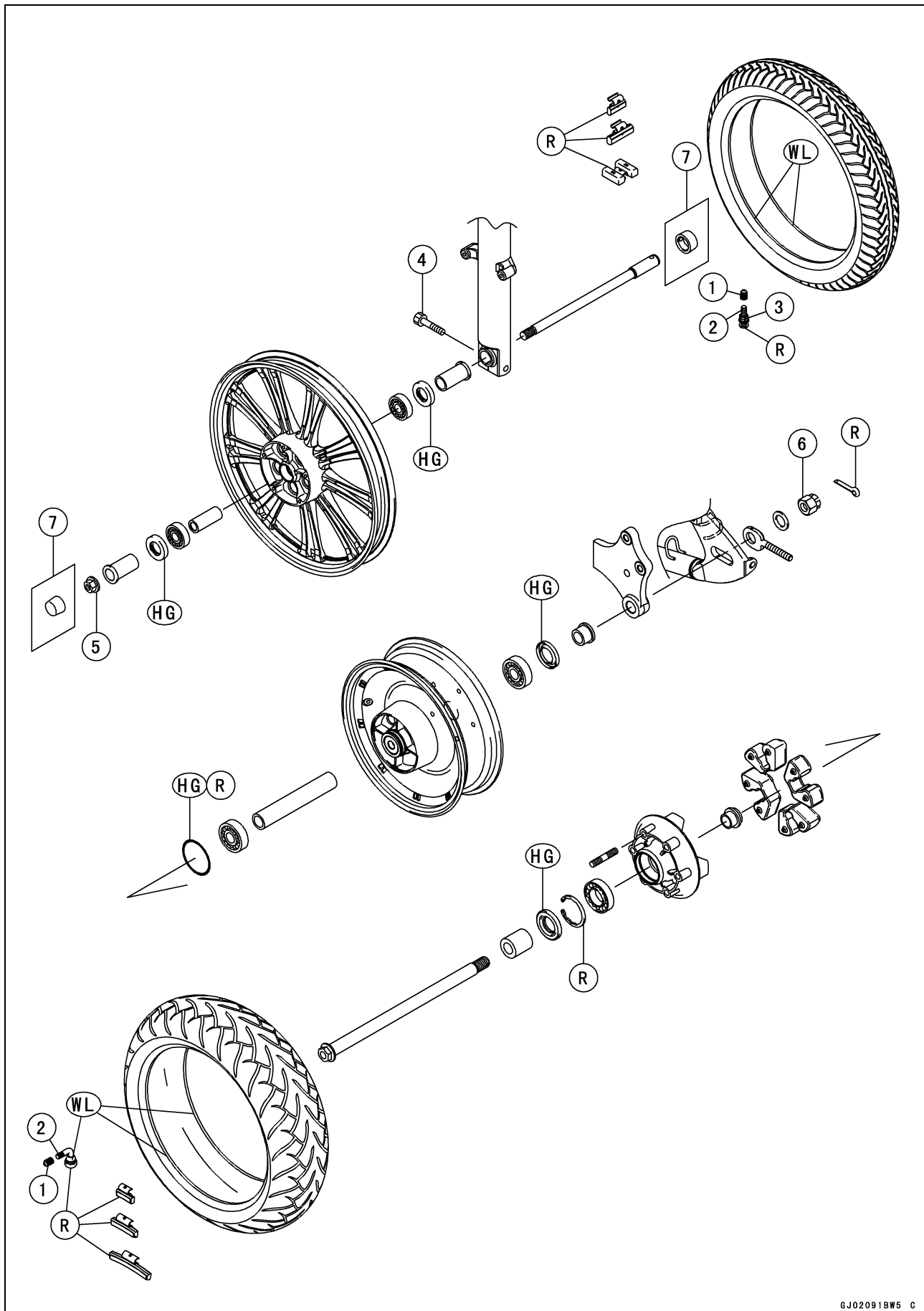

GJ020918W5 C

Exploded View

| No. | Fastener | Torque | | | Remarks |
|-----|-----------------------|--------|-------|-----------|---------|
| | | N·m | kgf·m | ft·lb | |
| 1 | Air Valve Cap | 0.15 | 0.015 | 1.3 in·lb | |
| 2 | Air Valve Core | 0.3 | 0.03 | 2.7 in·lb | |
| 3 | Air Valve Nuts | 1.5 | 0.15 | 13 in·lb | |
| 4 | Front Axle Clamp Bolt | 20 | 2.0 | 15 | |
| 5 | Front Axle Nut | 108 | 11.0 | 80 | |
| 6 | Rear Axle Nut | 108 | 11.0 | 80 | |

7. Axle Caps (EUR, BR and PH Models)

HG: Apply high-temperature grease.

R: Replacement Parts

WL: Apply soap and water solution or rubber lubricant.

10-4 WHEELS/TIRES

Specifications

| Item | Standard | Service Limit |
|--------------------------------|---|---|
| Wheels (Rims) | | |
| Rim Runout: | | |
| Axial | TIR 0.5 mm (0.02 in.) or less | TIR 1.0 mm (0.04 in.) |
| Radial | TIR 0.8 mm (0.03 in.) or less | TIR 1.0 mm (0.04 in.) |
| Axle Runout/100 mm (3.94 in.): | | |
| Front | TIR 0.05 mm (0.002 in.) or less | TIR 0.2 mm (0.008 in.) |
| Rear | TIR 0.03 mm (0.001 in.) or less | TIR 0.2 mm (0.008 in.) |
| Wheel Balance | 10 g (0.35 oz.) or less | — — — |
| Balance Weights | 10 g (0.35 oz.), 20 g (0.71 oz.), 30 g (1.06 oz.) | — — — |
| Rim Size: | | |
| Front | J21 M/C × MT 2.15 | — — — |
| Rear | J15 M/C × MT 4.50 | — — — |
| Tires | | |
| Air Pressure (when Cold): | | |
| Front: | Up to 180 kg (397 lb) load: 280 kPa (2.80 kgf/cm ² , 40 psi) | — — — |
| Rear: | Up to 97.5 kg (215 lb) load: 200 kPa (2.00 kgf/cm ² , 28 psi) 97.5 kg ~ 180 kg (215 lb ~ 397 lb) load: 225 kPa (2.25 kgf/cm ² , 32 psi) | — — — |
| Tread Depth: | | |
| Front | 4.5 mm (0.18 in.) | 1 mm (0.04 in.) (AT, CH, DE) 1.6 mm (0.06 in.) |
| Rear | 7.4 mm (0.29 in.) | Up to 130 km/h (80 mph): 2 mm (0.08 in.) Over 130 km/h (80 mph): 3 mm (0.12 in.) |
| Standard Tires: | Make, Type | Size |
| Front | DUNLOP, D404FJ | 80/90-21 M/C 48H |
| Rear | DUNLOP, D404 | 180/70-15 M/C 76H |

WARNING

Some replacement tires may adversely affect handling and cause an accident resulting in serious injury or death. To ensure proper handling and stability, use only the recommended standard tires for replacement, inflated to the standard pressure.

Special Tools

Bearing Driver Set:
57001-1129

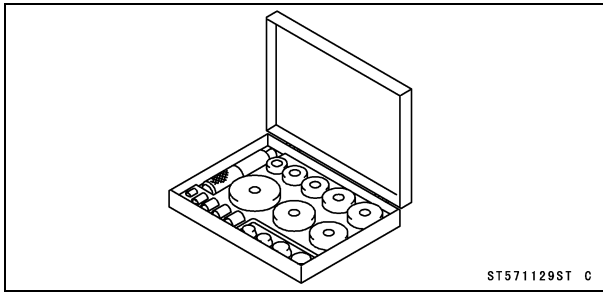

Bearing Remover Shaft, $\phi 9$:
57001-1265

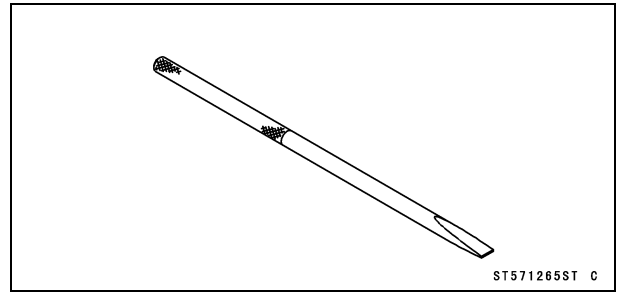

Jack:
57001-1238

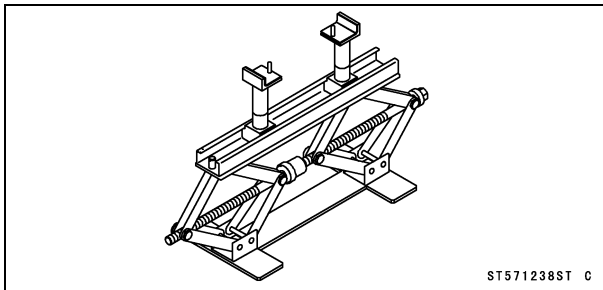

Bearing Remover Head, $\phi 20 \times \phi 22$:
57001-1293

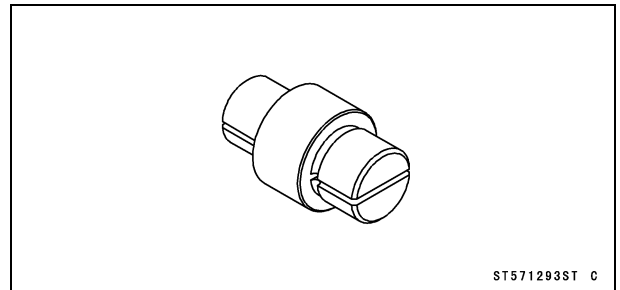

10-6 WHEELS/TIRES

Wheels (Rims)

Front Wheel Removal

- Remove:
 - Front Caliper Mounting Bolts [A]
 - Front Caliper [B]

- Remove:
 - Axle Caps (EUR Models)
 - Front Axle Clamp Bolt [A] (Loosen)
 - Front Axle Nut [B]

- Using the jack under the frame pipe, and a commercially available jack under the engine, raise the front wheel off the ground until the rear wheel touches the ground.

Special Tool - Jack: 57001-1238

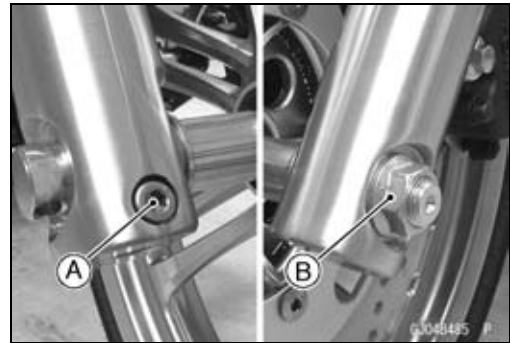
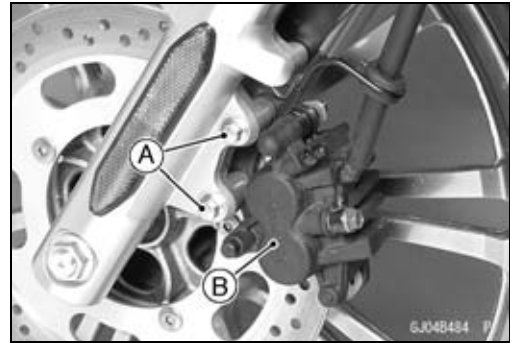

- Using the jack under the frame pipe, and a commercially available jack under the engine, raise the front wheel off the ground until the rear wheel touches the ground.

Special Tool - Jack: 57001-1238

NOTICE

Be sure to put the rear wheel on the ground when removing the front wheel, or the motorcycle may fall over. The motorcycle could be damaged.

⚠ WARNING

Be sure to put the rear wheel on the ground when removing the front wheel, or the motorcycle may fall over. It could cause an accident and injury.

- Pull out the axle to the right, and remove the front wheel and collars.

NOTICE

Do not lay the wheel on the ground with the disc facing down. This can damage or warp the disc. Place wooden blocks under the wheel so that the disc does not touch the ground.

Wheels (Rims)

Front Wheel Installation

- Apply high-temperature grease to the grease seal lips.
- Fit the collars [A] on the both sides of the hub.
- The collars are identical.
- Insert the axle from the right side of the wheel.
- Tighten:

Torque - Front Axle Nut: 108 N·m (11.0 kgf·m, 80 ft·lb)

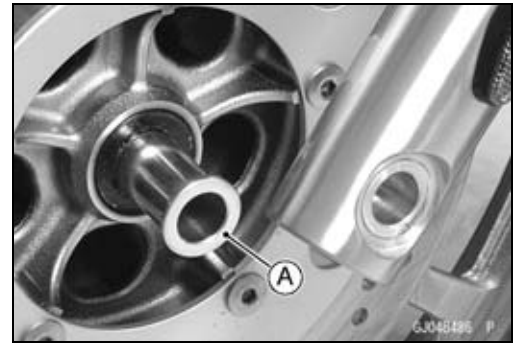

- Tighten:

Torque - Front Axle Clamp Bolt [A]: 20 N·m (2.0 kgf·m, 15 ft·lb)



- Install the front caliper (see Caliper Installation in the Brakes chapter).
- Check the front brake effectiveness (see Brake Operation Inspection in the Periodic Maintenance chapter).

⚠ WARNING

After servicing, it takes several applications of the brake lever before the brake pads contact the disc, which could result in increased stopping distance and cause an accident resulting in injury or death. Do not attempt to ride the motorcycle until a firm brake lever is obtained by pumping the lever until the pads are against the disc.

Rear Wheel Removal

- Remove the mufflers (see Muffler Removal in the Engine Top End chapter).
- Using the jack under the frame pipe, raise the rear wheel off the ground.

NOTICE

Be sure to put the front wheel on the ground when removing the rear wheel, or the motorcycle may fall over. The motorcycle could be damaged.

⚠ WARNING

Be sure to put the front wheel on the ground when removing the rear wheel, or the motorcycle may fall over. It could cause an accident and injury.

Special Tool - Jack: 57001-1238

10-8 WHEELS/TIRES

Wheels (Rims)

- Squeeze the brake lever slowly and hold it with a band [A].

NOTICE

Be sure to hold the front brake when removing the rear wheel, or the motorcycle may fall over. The motorcycle could be damaged.

⚠ WARNING

Motorcycle may fall over unexpectedly resulting in an accident or injury. Be sure to hold the front brake when removing the rear wheel.



- Remove:
 - Rear Caliper Mounting Bolts [A]
 - Rear Caliper [B]

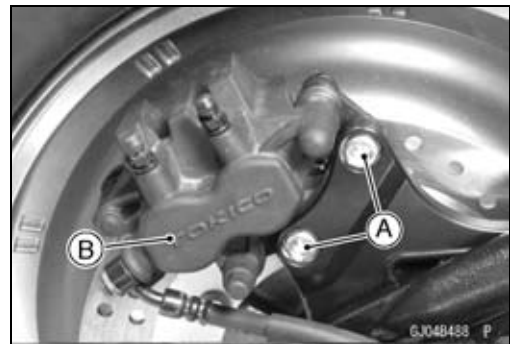

- Remove:
 - Cotter Pin [A]
 - Axle Nut [B]
 - Washer

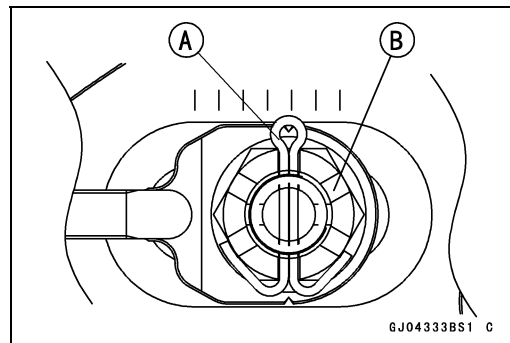

- Remove:
 - Bolts [A]
 - Drive Belt Cover [B]
- Loosen the belt adjuster locknuts [C] and adjuster nuts [D] fully.
- Move the rear wheel forward.

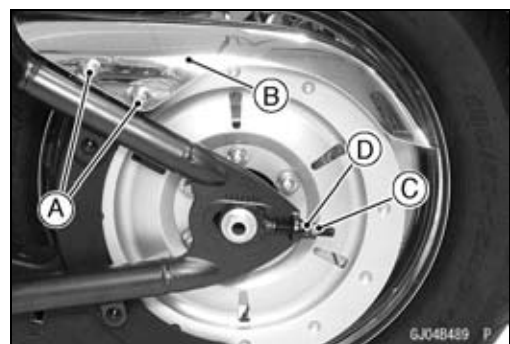

- Place the suitable stand (about 30 mm (1.2 in.) thickness) under the rear tire.
- Reduce the jack until the rear axle shaft pull out easily, and remove the axle shaft.

Wheels (Rims)

- Incline the rear wheel to the right diagonally.
- Remove the drive belt [A] from the rear pulley [B].



- Raise the jack until the wheel clear the rear fender to remove the rear wheel [A].

NOTICE

Do not lay the wheel on the ground with the disc facing down. This can damage or warp the disc. Place wooden blocks under the wheel so that the disc does not touch the ground.



Rear Wheel Installation

- Apply high-temperature grease to the grease seal lips.
- Fit the collars [A] on the both sides of the hub.
- Place the suitable stand (about 30 mm (1.2 in.) thickness) under the installing wheel.
- Raise the jack until the wheel clear the rear fender.



- Install the caliper bracket [A] onto the swingarm stop [B].
- Reduce the jack until the rear axle install easily.

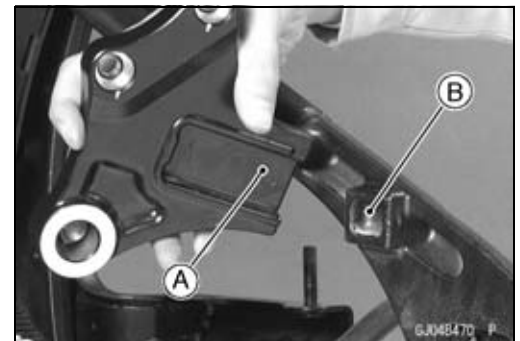

- Engage the drive belt [A] with the pulley [B].
- Insert the axle from the left side of the rear wheel.
- Tighten:
Torque - Rear Axle Nut: 108 N·m (11.0 kgf·m, 80 ft·lb)



10-10 WHEELS/TIRES

Wheels (Rims)

- Insert a new cotter pin [A].

NOTE

- When inserting the cotter pin, if the slots in the nut do not align with the cotter pin hole in the axle, tighten the nut clockwise [B] up to next alignment.
- It should be within 30°.
- Loosen once and tighten again when the slot goes past the nearest hole.

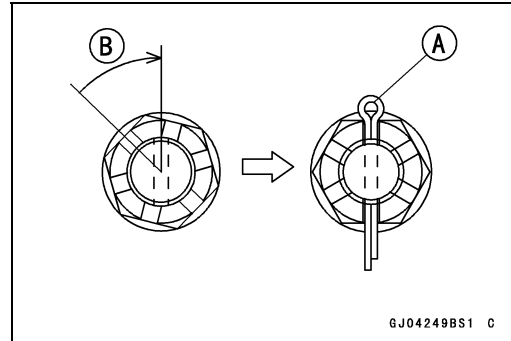

- Bend the cotter pin [A] over the nut [B] as shown in the figure.

⚠ WARNING

A loose axle nut can lead to an accident resulting in serious injury or death. Tighten the axle nut to the proper torque and install a new cotter pin.

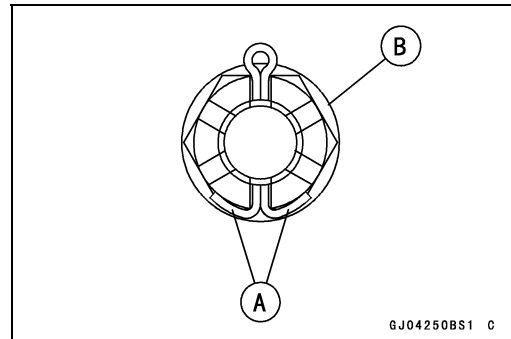

- Install the rear caliper (see Caliper Installation in the Brakes chapter).
- Check the rear brake effectiveness (see Brake Operation Inspection in the Periodic Maintenance chapter).

⚠ WARNING

After servicing, it takes several applications of the brake pedal before the brake pads contact the disc, which could result in increased stopping distance and cause an accident resulting in injury or death. Do not attempt to ride the motorcycle until a firm brake pedal is obtained by pumping the pedal until the pads are against the disc.

Wheels (Rims)

Wheel Inspection

- Raise the front/rear wheel off the ground with jack.
- Special Tool - Jack: 57001-1238**
- Spin the wheel lightly, and check for roughness or binding.
- ★ If roughness or binding is found, replace the hub bearings.
- Inspect the wheel for small cracks, dents, bending, or warp.
- ★ If there is any damage to the wheel, replace the wheel.
- Remove the wheel, and support it with the tire by the axle.
- Measure the rim runout, axial [A] and radial [B], with a dial gauge.
- ★ If rim runout exceeds the service limit, check the hub bearings.
- ★ If the problem is not due to the bearings, replace the wheel.

Rim Runout (with tire installed)

Standard:

Axial **TIR 0.5 mm (0.02 in.) or less**

Radial **TIR 0.8 mm (0.03 in.) or less**

Service Limit:

Axial **TIR 1.0 mm (0.04 in.)**

Radial **TIR 1.0 mm (0.04 in.)**

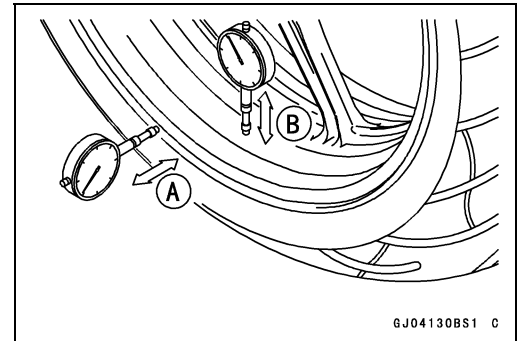

⚠ WARNING

Damaged wheel parts may fail and cause an accident resulting in serious injury or death. Never attempt to repair a damaged wheel part. If the wheel part is damaged, it must be replaced with a new one.

Axle Inspection

- Remove the front and rear axles (see Front/Rear Wheel Removal).
- Visually inspect the front and rear axle for damages.
- ★ If the axle is damaged or bent, replace it.
- Place the axle in V blocks that are 100 mm (3.94 in.) [A] apart, and set a dial gauge [B] on the axle at a point halfway between the blocks. Turn [C] the axle to measure the runout. The difference between the highest and lowest dial readings is the amount of runout.
- ★ If axle runout exceeds the service limit, replace the axle.

Axle Runout/100 mm (3.94 in.)

Standard:

Front **TIR 0.05 mm (0.002 in.) or less**

Rear **TIR 0.03 mm (0.001 in.) or less**

Service Limit: **TIR 0.2 mm (0.008 in.)**

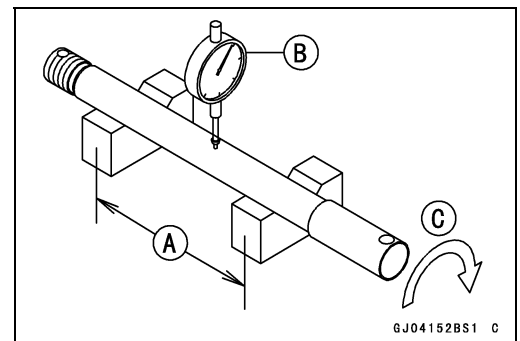

10-12 WHEELS/TIRES

Wheels (Rims)

Balance Inspection

- Remove the front and rear wheels (see Front/Rear Wheel Removal).
- Support the wheel so that it can be spun freely.
- Spin the wheel lightly, and mark [A] the wheel at the top when the wheel stops.
- Repeat this procedure several times. If the wheel stops of its own accord in various positions, it is well balanced.
- ★ If the wheel always stops in one position, adjust the wheel balance (see Balance Adjustment).

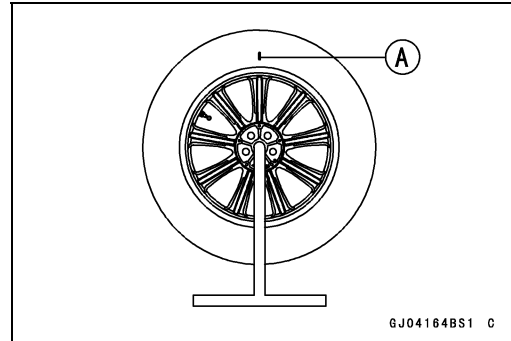

Balance Adjustment

- ★ If the wheel always stops in one position, provisionally attach a balance weight [A] on the rim at the marking using adhesive tape.
- Rotate the wheel 1/4 turn [B], and see whether or not the wheel stops in this position. If it does, the correct balance weight is being used.
- ★ If the wheel rotates and the weight goes up, replace the weight with the next heavier size. If the wheel rotates and the weight goes down, replace the weight with the next lighter size. Repeat these steps until the wheel remains at rest after being rotated 1/4 turn.
- Rotate the wheel another 1/4 turn and then another 1/4 turn to see if the wheel is correctly balanced.
- Repeat the entire procedure as many times as necessary to achieve correct wheel balance.
- Permanently install the balance weight.

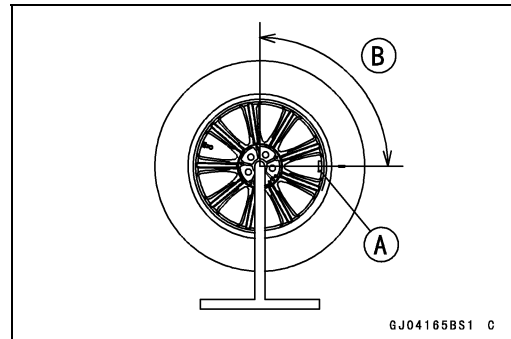

Balance Weight Removal

Front

- Insert a standard screwdriver [A] [B] between the rib [C] and the weight [D] as shown in the figure.
- Pry the balance weight with two screwdrivers and remove the balance weight.
- Discard the used balance weight.

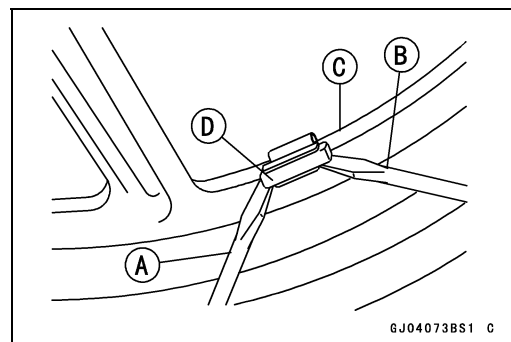

NOTICE

Do not tap the screwdrivers. The rim could be damaged.

Rear

- (a) When the tire is not on the rim.
- Push [A] the blade portion toward the outside with a standard screwdriver, and slip the weight off the rim flange.
- Discard the used balance weight.

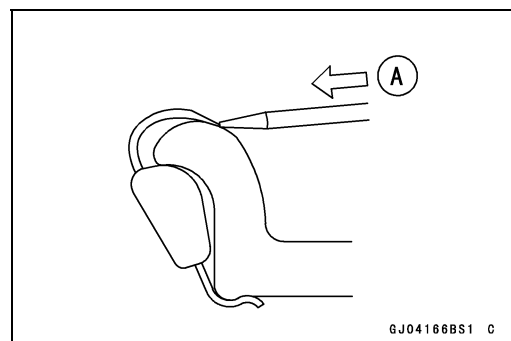

Wheels (Rims)

(b) When the tire is on the rim.

- Pry [A] the balance weight off the rim flange using a standard screwdriver as shown in the figure.
- Insert a tip of the screwdriver between the tire bead [B] and weight blade [C] until the end of the tip reaches the end of the weight blade.
- Push the driver grip toward the tire so that the balance weight slips off the rim flange.
- Discard the used balance weight.

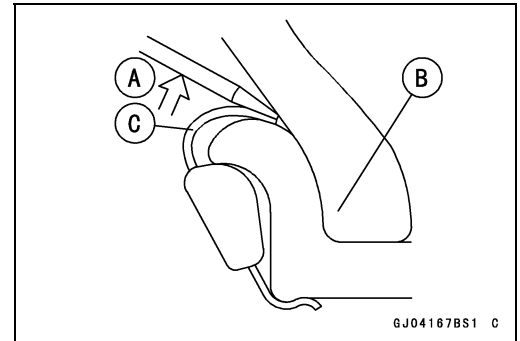

Balance Weight Installation

Front

- Check if the weight portion has any play on the blade [A] and clip [B].
- ★ If it does, discard it.

⚠ WARNING

Unbalanced wheels can create an unsafe riding condition. If the balance weight has any play on the rib of the rim, the blade and/or clip have been stretched. Replace the loose balance weight. Do not reuse used balance weight.

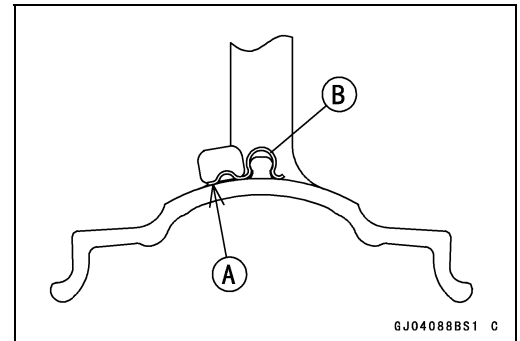

Balance Weight

| Part Number | Weight |
|-------------|-----------------|
| 41075-0007 | 10 g (0.35 oz.) |
| 41075-0017 | 20 g (0.71 oz.) |
| 41075-0018 | 30 g (1.06 oz.) |

NOTE

- Balance weights are available from Kawasaki dealers in 10, 20, and 30 grams (0.35, 0.71, and 1.06 oz.) sizes. An imbalance of less than 10 grams (0.35 oz.) will not usually affect running stability.
- Do not use four or more balance weight (more than 90 gram, 3.17 oz.). If the wheel requires an excess balance weight, disassemble the wheel to find the cause.

- Slip the balance weight [A] onto the rib [B] by pushing or lightly hammering [C] the clip [D].
 Left Side [E]
 Right Side [F]

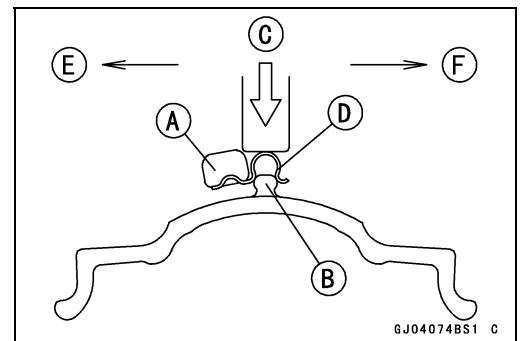

10-14 WHEELS/TIRES

Wheels (Rims)

- Be sure to install the balance weight.
- Check that the blade [A] and clip [B] are fully seated on the rim [C] and that the clip is hooked over the rib [D].
- Left Side [E]
- Right Side [F]

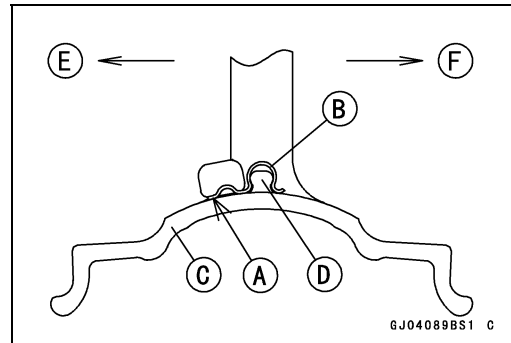

Rear

- Check if the weight portion has any play on the blade-and-clip plate.
- ★ If it does, discard it.

⚠ WARNING

Unbalanced wheels can create an unsafe riding condition. If the balance weight has any play on the rib of the rim, the blade and/or clip have been stretched. Replace the loose balance weight. Do not reuse used balance weight.

Balance Weight

| Part Number | Weight |
|-------------|-----------------|
| 41075-0014 | 10 g (0.35 oz.) |
| 41075-0015 | 20 g (0.71 oz.) |
| 41075-0016 | 30 g (1.06 oz.) |

NOTE

- Balance weights are available from Kawasaki dealers in 10, 20, and 30 grams (0.35, 0.71, and 1.06 oz.) sizes. An imbalance of less than 10 grams (0.35 oz.) will not usually affect running stability.
- Do not use four or more balance weight (more than 90 gram, 3.17 oz.). If the wheel requires an excess balance weight, disassemble the wheel to find the cause.
- Lubricate the balance weight blade, tire bead, and rim flange with a soap and water solution or rubber lubricant. This helps the balance weight slip onto the rim flange.

NOTICE

Do not lubricate the tire bead with engine oil or petroleum distillates because they will deteriorate the tire.

Wheels (Rims)

- Install the balance weight on the rim.
- Slip the weight on the rim flange [A] by pushing or lightly hammering [B] the weight in the direction shown in the figure.
 - Tire Bead [C]
 - Blade [D]

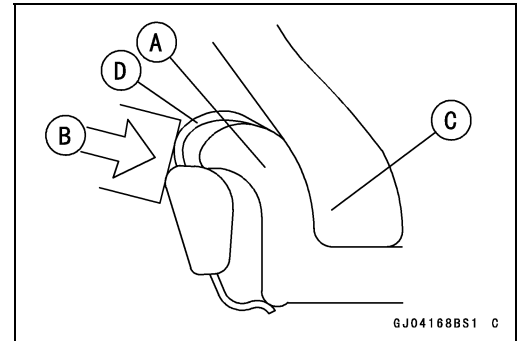

- Check that the blade [A] and weight [B] seat fully on the rim flange [C], and that the clip [D] is hooked over the rim ridge [E] and reaches rim flat portion.

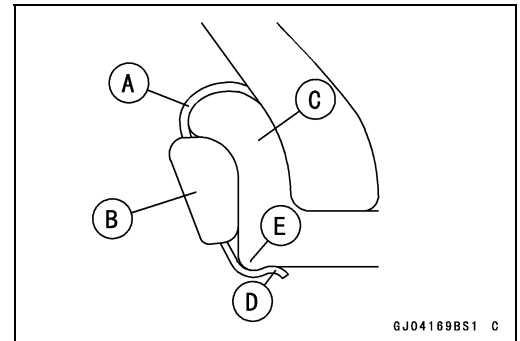

- Install the balance weight on the rim flange as shown in the figure.
 - Left Side [A]
 - Right Side [B]

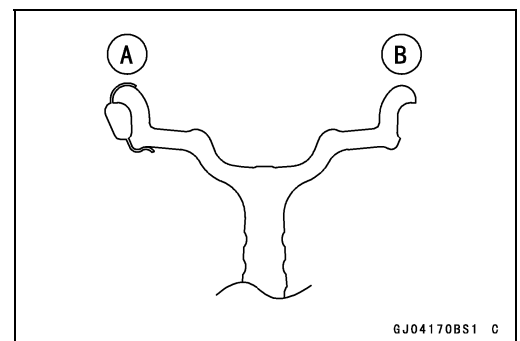

10-16 WHEELS/TIRES

Tires

Air Pressure Inspection/Adjustment

- Refer to the Air Pressure Inspection in the Periodic Maintenance chapter.

Tire Inspection

- Refer to the Wheel/Tire Damage Inspection in the Periodic Maintenance chapter.

Tire Removal

- Remove:
 - Wheel (see Front/Rear Wheel Removal)
 - Valve Core (Let out the air)
- To maintain wheel balance, mark the air valve position on the tire with chalk so that the tire can be reinstalled in the same position.
 - Chalk Mark or Yellow Mark [A]
 - Air Valve [B]
 - Align [C]
- Lubricate the tire beads and rim flanges on both sides with a soap and water solution or rubber lubricant. This helps the tire beads slip off the rim flanges.

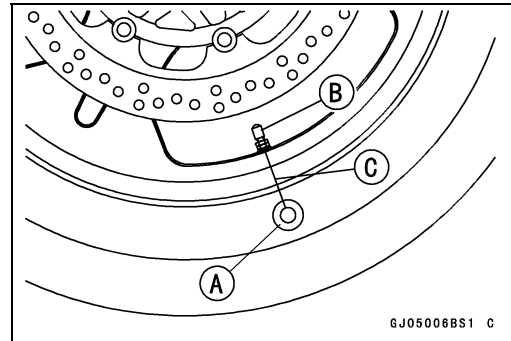

NOTICE

Never lubricate with engine oil or petroleum distillates because they will deteriorate the tire.

- Remove the tire from the rim using a suitable commercially available tire changer.

NOTE

- *The tires cannot be removed with hand tools because they fit the rims too tightly.*

Tire Installation

⚠ WARNING

Some replacement tires may adversely affect handling and cause an accident resulting in serious injury or death. To ensure proper handling and stability, use only the recommended standard tires for replacement, inflated to the standard pressure.

- Inspect the rim and tire, and replace them if necessary.
- Clean the sealing surfaces of the rim and tire, and smooth the sealing surfaces of the rim with a fine emery cloth if necessary.
- Remove the air valve and discard it.

NOTICE

Replace the air valve whenever the tire is replaced. Do not reuse the air valve.

Tires

- Insert the new air valve in the front wheel rim.
 - Valve Cap [A]
 - Valve Body [B]
 - Valve Nuts [C]
 - Valve Washer [D]
 - Rim [E]
 - Valve Grommet [F]
- Remove the valve cap, valve nuts, valve washer and insert the valve stem through the rim from the inside out.
- Tighten:
 - Torque - Air Valve Nuts: 1.5 N·m (0.15 kgf·m, 13 in·lb)**
 - Air Valve Cap: 0.15 N·m (0.015 kgf·m, 1.3 in·lb)**
 - Air Valve Core: 0.3 N·m (0.03 kgf·m, 2.7 in·lb)**

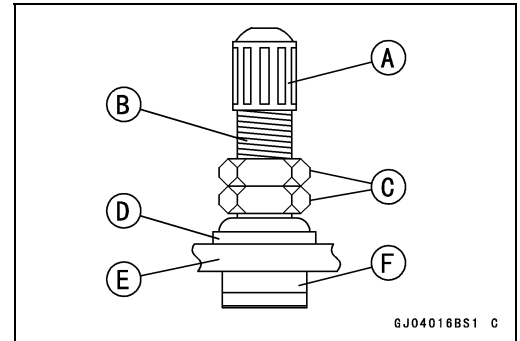

- Insert the new air valve in the rear wheel rim.
- Remove the valve cap, lubricate the stem seal [A] with a soap and water solution or rubber lubricant, and pull the valve stem through the rim [B] from the inside out until it snaps into place.
 - Viewed from Rear [C]
 - 20° [D]

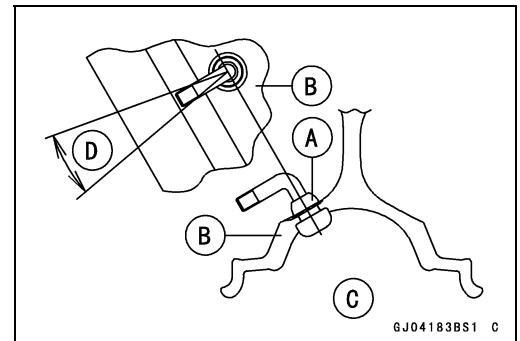

| |
|---|
| NOTICE |
| Do not use engine oil or petroleum distillates to lubricate the stem because they will deteriorate the rubber. |

- Tighten:
 - Torque - Air Valve Cap: 0.15 N·m (0.015 kgf·m, 1.3 in·lb)**
 - Air Valve Core: 0.3 N·m (0.03 kgf·m, 2.7 in·lb)**

- Apply a soap and water solution, or rubber lubricant to the rim flange and tire beads.

| |
|---|
| NOTICE |
| Never lubricate with mineral oil (engine oil) or gasoline because they will cause deterioration of the tire. |

- Check the tire rotation mark on the front and rear tires and install them on the rim accordingly.
 - Tire Rotation Mark [A]
 - Rotating Direction [B]

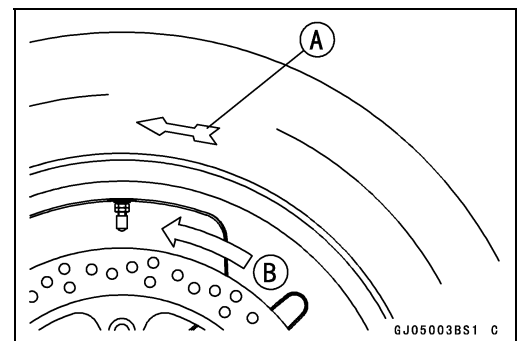

10-18 WHEELS/TIRES

Tires

- Position the tire on the rim so that the valve [A] align with the tire balance mark [B] (the chalk mark made during removal, or the yellow paint mark on a new tire).
- Install the tire bead over the rim flange using a suitable commercially available tire changer.
- Lubricate the tire beads and rim flanges with a soap and water solution or rubber lubricant to help seat the tire beads in the sealing surfaces of the rim while inflating the tire.
- Center the rim in the tire beads, and inflate the tire with compressed air until the tire beads seat in the sealing surfaces.

⚠ WARNING

Overinflating a tire can cause it to explode, causing serious injury or death. Be sure to install the valve core whenever inflating the tire, and do not inflate the tire to more than 400 kPa (4.0 kgf/cm², 57 psi).

- Check to see that the bead lines [A] on both sides of the tire sidewalls are parallel with the rim flanges.
- ★ If the rim flanges and tire sidewall bead lines are not parallel, remove the valve core.
- Lubricate the rim flanges and tire beads.
- Install the valve core and inflate the tire again.
- After the tire beads seat in the rim flanges, check for air leakage.
- Inflate the tire slightly above standard inflation.
- Use a soap and water solution or submerge the tire, and check for bubbles that would indicate leakage.
- Adjust the air pressure to the specified pressure (see Air Pressure Inspection in the Periodic Maintenance chapter).
- Adjust the wheel balance (see Balance Adjustment).

Tire Repair

Currently two types of repair for tubeless tires have come into wide use. One type is called a temporary (external) repair which can be carried out without removing the tire from the rim, and the other type is called permanent (internal) repair which requires tire removal. It is generally understood that higher running durability is obtained by permanent (internal) repairs than by temporary (external) ones. Also, permanent (internal) repairs have the advantage of permitting a thorough examination for secondary damage not visible from external inspection of the tire. For these reasons, Kawasaki does not recommend temporary (external) repair. Only appropriate permanent (internal) repairs are recommended. Repair methods may vary slightly from make to make. Follow the repair methods indicated by the manufacturer of the repair tools and materials so that safe results can be obtained.

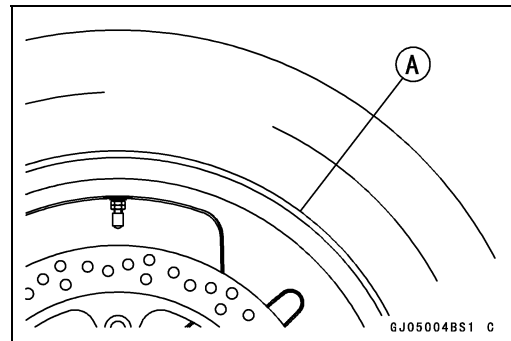
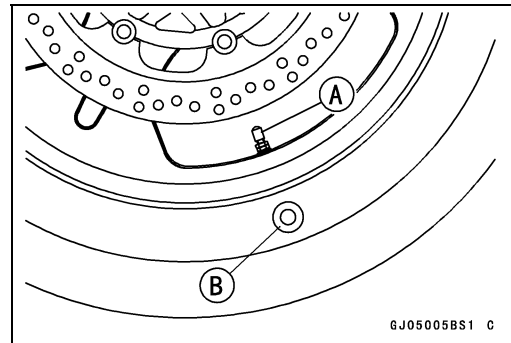

Hub Bearing

Hub Bearing Removal

- Remove the wheel (see Front/Rear Wheel Removal), and take out the following.

Front

- Grease Seals [A]

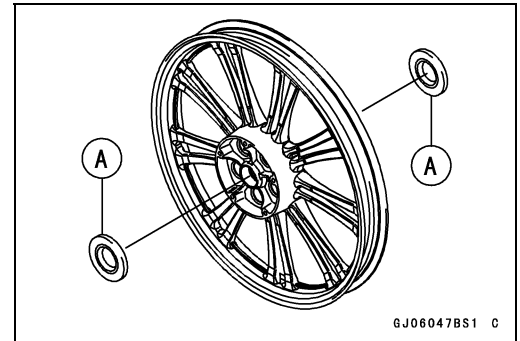

Rear

- Coupling [A]
- Collar [B]
- O-ring [C]
- Grease Seal [D]

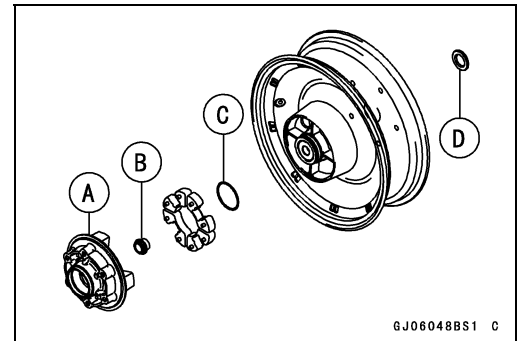

- Take the bearings [A] out of the hub, using the bearing remover.

Special Tools - Bearing Remover Shaft, $\phi 9$ [B]: 57001-1265
Bearing Remover Head, $\phi 20 \times \phi 22$ [C]: 57001-1293

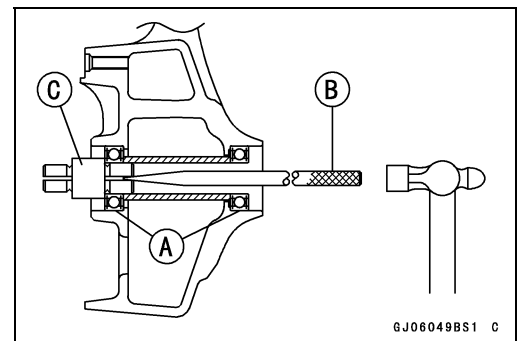

Hub Bearing Installation

- Before installing the hub bearings, blow any dirt or foreign particles out of the hub with compressed air to prevent contamination of the bearings.
- Replace the bearings with new ones.
- Install the front bearings the following sequence.
 - Press in the left side bearing [A] until it is bottomed.

Special Tool - Bearing Driver Set: 57001-1129

- Insert the collar [B] in the hub [C].
- Press in the right side bearing [D] until it is bottomed.
- Press in the rear bearings until they are bottomed.

Special Tool - Bearing Driver Set: 57001-1129

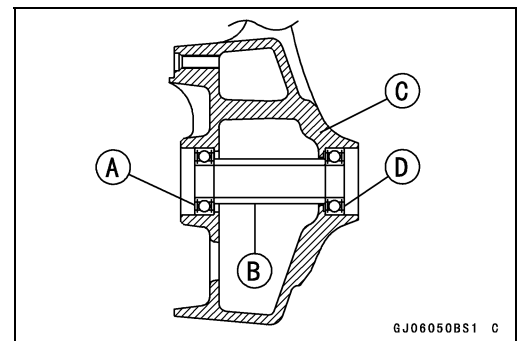

NOTE

- Install the bearings so that the marked side faces out.

10-20 WHEELS/TIRES

Hub Bearing

- Replace the grease seals with new ones.
- Press in the grease seal [A] so that the seal surface is flush [B] with the end of the hole.
- Apply high-temperature grease to the grease seal lips.

Special Tool - Bearing Driver Set [C]: 57001-1129

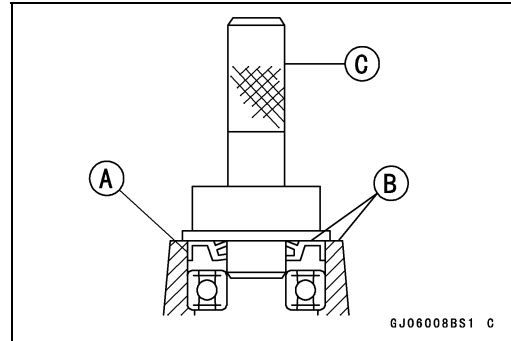

Hub Bearing Inspection

Since the hub bearings are made to extremely close tolerances, the clearance can not normally be measured.

NOTE

○ Do not remove any bearings for inspection. If any bearings are removed, they will need to be replaced with new ones.

- Turn each bearing in the hub back and forth [A] while checking for plays, roughness or binding.
- ★ If bearing play, roughness or binding is found, replace the bearing.
- Examine the bearing seal [B] for tears or leakage.
- ★ If the seal is torn or is leaking, replace the bearing.

Hub Bearing Lubrication

NOTE

○ Since the hub bearings are packed with grease and sealed, lubrication is not required.

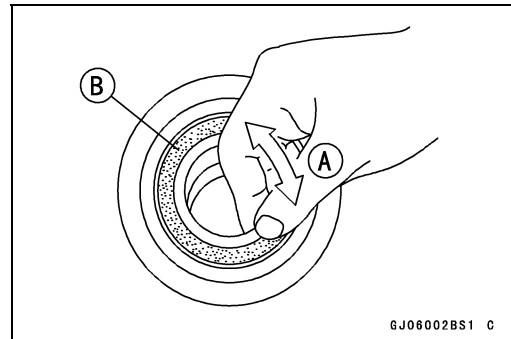

Final Drive

Table of Contents

| | |
|---|-------|
| Exploded View | 11-2 |
| Specifications | 11-4 |
| Special Tools | 11-5 |
| Drive Belt | 11-6 |
| Belt Handling Precautions..... | 11-6 |
| Drive Belt Wear Inspection | 11-7 |
| Drive Belt Deflection Inspection | 11-7 |
| Drive Belt Deflection Adjustment | 11-7 |
| Drive Belt Removal | 11-7 |
| Drive Belt Installation | 11-8 |
| Pulley and Coupling..... | 11-9 |
| Engine Pulley Cover Removal | 11-9 |
| Engine Pulley Cover Installation | 11-9 |
| Engine Pulley Removal..... | 11-9 |
| Engine Pulley Installation..... | 11-10 |
| Rear Pulley Removal | 11-10 |
| Rear Pulley Installation | 11-10 |
| Rear Pulley Coupling Removal..... | 11-11 |
| Rear Pulley Coupling Installation | 11-11 |
| Pulley Wear Inspection | 11-11 |
| Coupling Bearing Removal | 11-12 |
| Coupling Bearing Installation | 11-12 |
| Coupling Bearing Inspection..... | 11-13 |
| Rubber Damper Inspection | 11-13 |
| Belt Adjuster | 11-14 |
| Belt Adjuster Removal | 11-14 |
| Belt Adjuster Installation | 11-14 |

11-2 FINAL DRIVE

Exploded View

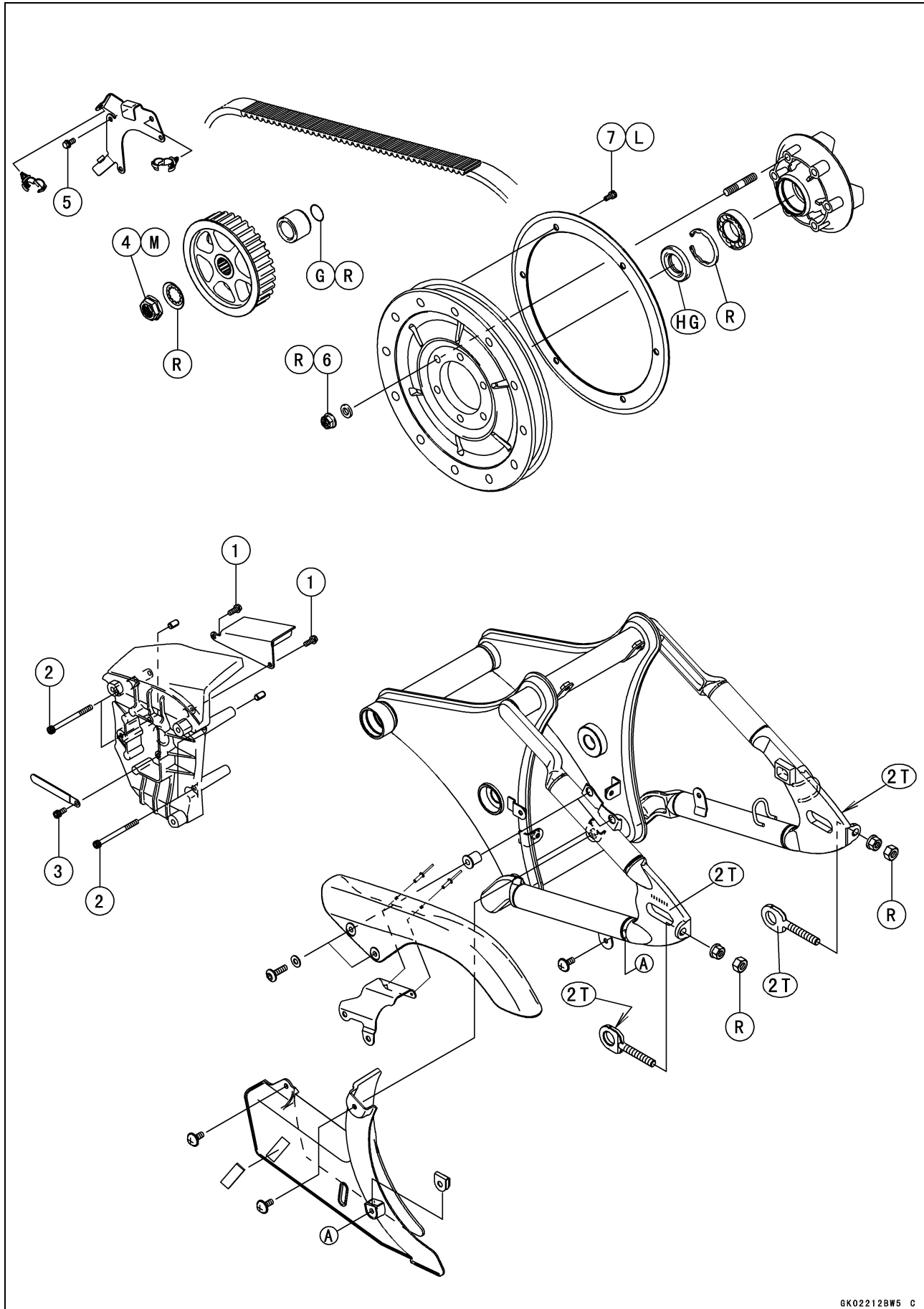

Exploded View

| No. | Fastener | Torque | | | Remarks |
|-----|---|--------|-------|----------|---------|
| | | N·m | kgf·m | ft·lb | |
| 1 | Drive Belt Guide Bolts | 9.8 | 1.0 | 87 in·lb | |
| 2 | Engine Pulley Cover Bolts | 9.8 | 1.0 | 87 in·lb | |
| 3 | Engine Pulley Cover Clamp Mounting Bolt | 9.8 | 1.0 | 87 in·lb | |
| 4 | Engine Pulley Mounting Nut | 127 | 13.0 | 94 | M |
| 5 | Engine Pulley Plate Bolts | 9.8 | 1.0 | 87 in·lb | |
| 6 | Rear Pulley Mounting Nuts | 59 | 6.0 | 44 | R |
| 7 | Rear Pulley Plate Bolts | 6.9 | 0.70 | 61 in·lb | L |

2T: Apply 2-stroke oil.

G: Apply grease.

HG: Apply high-temperature grease.

L: Apply a non-permanent locking agent.

M: Apply molybdenum disulfide grease.

R: Replacement Parts

11-4 FINAL DRIVE

Specifications

| Item | Standard | Service Limit |
|---|---|----------------|
| Drive Belt | | |
| Make | GATES, 153T | - - - |
| Belt Deflection (45 N, 4.6 kgf, 10 lb force) (When installing new belt or engine is remounted) | 1.5 ~ 4.0 mm (0.06 ~ 0.16 in.) 1.5 mm (0.06 in.) | - - - - - - |

Special Tools

Inside Circlip Pliers:
57001-143

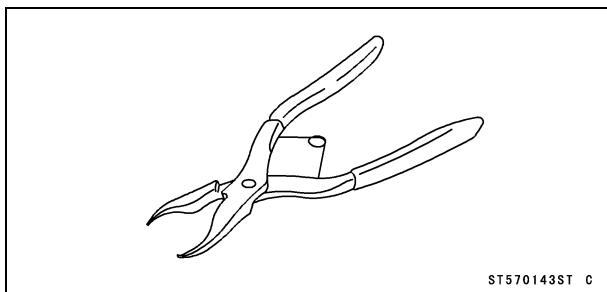

Pulley Holder:
57001-1572

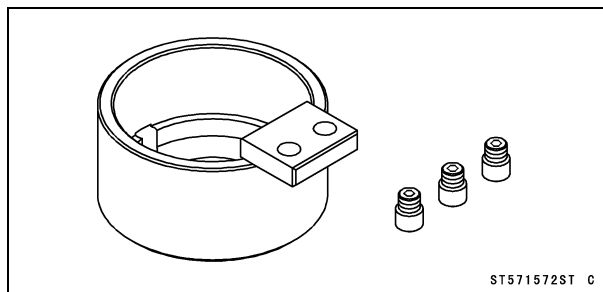

Oil Seal & Bearing Remover:
57001-1058

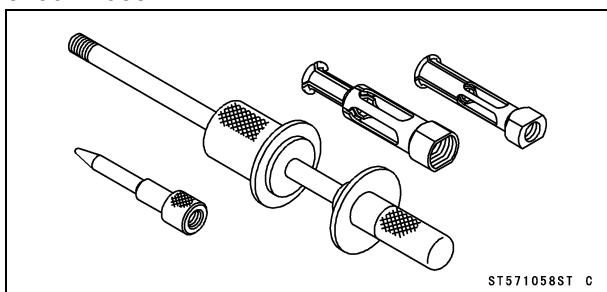

Grip:
57001-1591

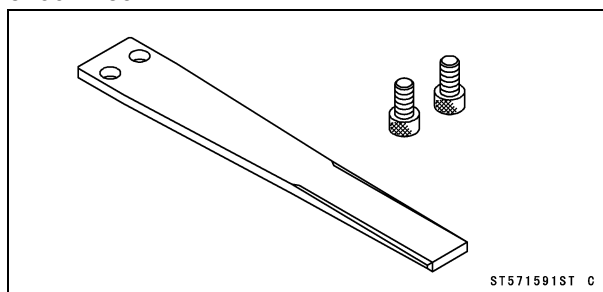

Bearing Driver Set:
57001-1129

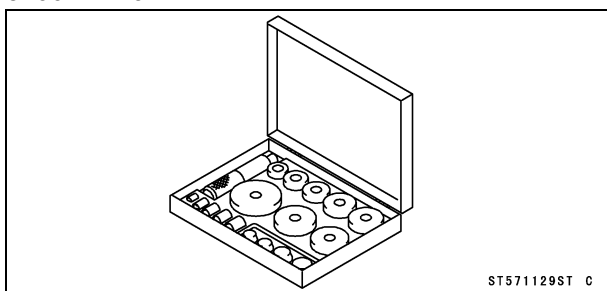

11-6 FINAL DRIVE

Drive Belt

The drive belt must be checked, and adjusted in accordance with the Periodic Maintenance Chart for safety and to prevent excessive wear. If the belt becomes badly worn or maladjusted-either too loose or too tight-the belt could jump off the pulley or break.

Belt Handling Precautions

NOTICE

Do not adhere battery electrolyte, thinner or other solvents to the belt. Immediately wash away any solvent that spills on the belt.

- Drive belt is extremely durable and give long life in a properly designed drive. However, improper handling of the belt before or during installation can result in dramatically shortened service life.
- The belt's tensile cords are designed to carry large loads in tension but not compression.
- Compression causes damage to the tensile cords of the belt and can also lead to adhesion problems.
- Handling situations that can cause compression in tensile cord include aggressive bending and twisting.
- When assembly, handling and storage, the forward bending [A] radius of the drive belt [B] shall not be smaller than 63.5 mm (2.50 in.) [C].

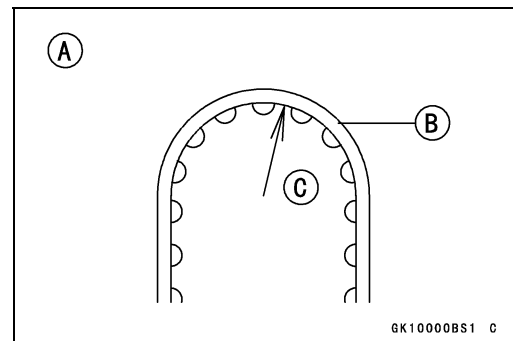

- When assembly, handling and storage, the back bending [A] radius of the drive belt [B] shall not be smaller than 127 mm (5.00 in.) [C].

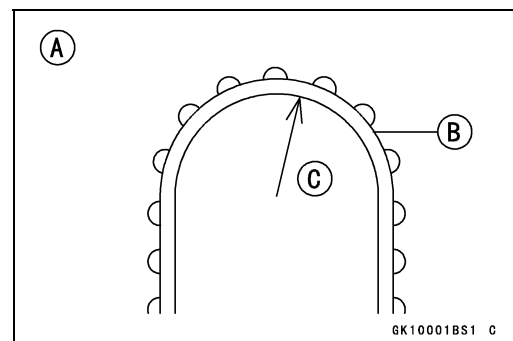

Drive Belt

- Do not twist [A] the drive belt [B] as shown in the figure.
- This includes coiling the belt to make it smaller for packaging.

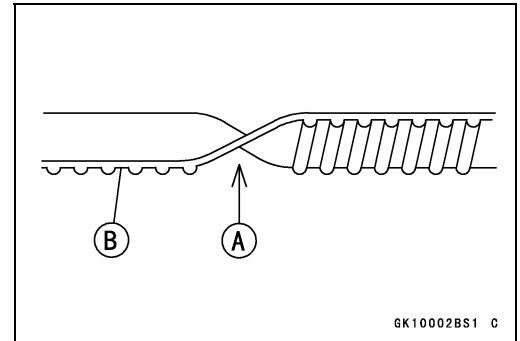

- Do not use tools [A] to pry [B] the drive belt [C] onto the application.
- Bring the rear pulley [D] front side so that the belt can be easily put on by hand.

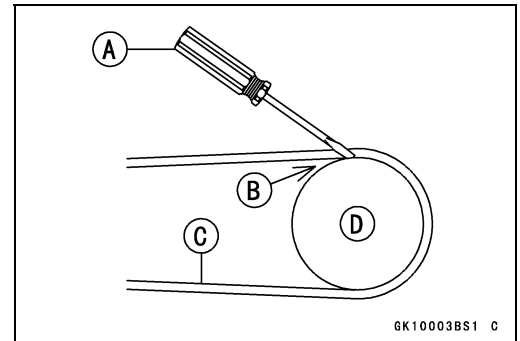

Drive Belt Wear Inspection

- Refer to the Belt Wear and Damage Inspection in the Periodic Maintenance chapter.

Drive Belt Deflection Inspection

- Refer to the Belt Deflection Inspection in the Periodic Maintenance chapter.

Drive Belt Deflection Adjustment

- Refer to the Belt Deflection Adjustment in the Periodic Maintenance chapter.

Drive Belt Removal

- Remove:
 - Rear Wheel (see Rear Wheel Removal in the Wheels/Tires chapter)
 - Engine Pulley (see Engine Pulley Removal)

NOTE

○ Before removing, observe the direction the belt's printed information [A] (such as manufacturer's name) is facing so that it may be reinstalled on the pulleys to rotate in the same direction as originally installed.

- Remove the drive belt [B].

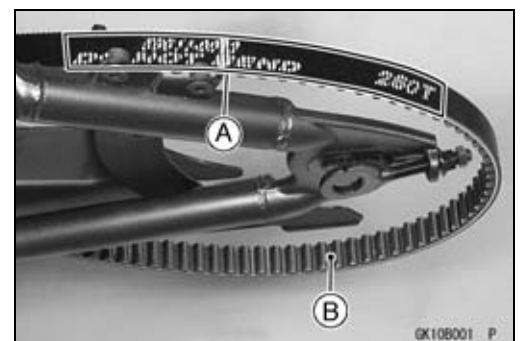

11-8 FINAL DRIVE

Drive Belt

Drive Belt Installation

- Installation is the reverse of removal. Note the following.

NOTE

- *Be sure the printed information faces the same direction so the belt rotates in the same direction as originally instead. When installing a new belt, install it so the printed information can be read from left side of the motorcycle.*
- Tighten the swingarm pivot shaft nut to the specified torque (see Exploded View section in the Suspension chapter).
- Adjust the drive belt deflection (see Belt Deflection Adjustment in the Periodic Maintenance chapter).

Pulley and Coupling

Engine Pulley Cover Removal

- Remove:
 - Alternator Outer Cover (see Alternator Outer Cover Removal in the Electrical System chapter)
 - Bolt [A]
 - Clamp [B]
 - Bolts [C]
 - Engine Pulley Cover [D]

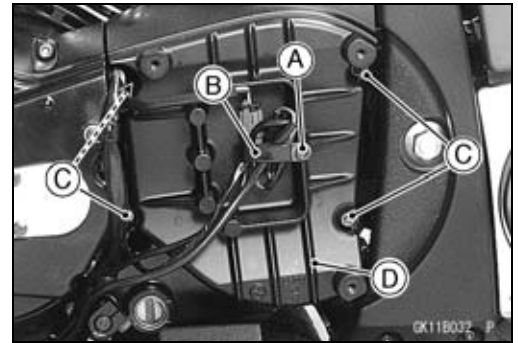

Engine Pulley Cover Installation

- Install the drive belt guide [A].
- Tighten:
 - Torque - Drive Belt Guide Bolts [B] : 9.8 N·m (1.0 kgf·m, 87 in·lb)

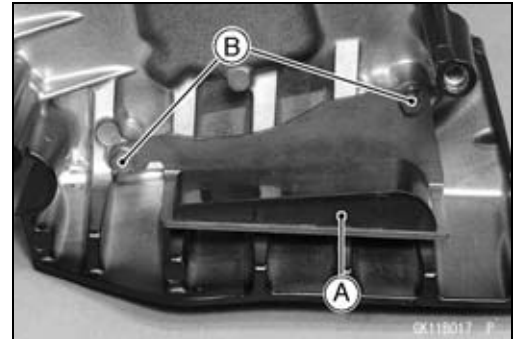

- Confirm the position of the dowel pins [A] as shown in the figure.

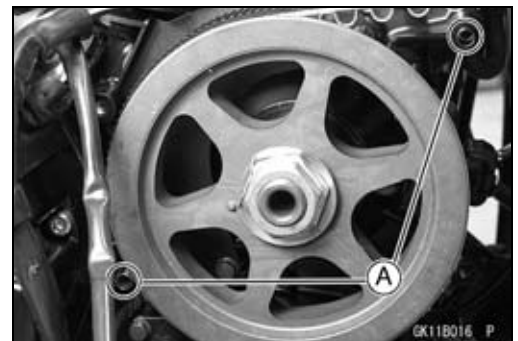

- Install the engine pulley cover [A].
- Tighten:
 - Torque - Engine Pulley Cover Bolts [B] : 9.8 N·m (1.0 kgf·m, 87 in·lb)
 - Engine Pulley Cover Clamp Mounting Bolt [C]: 9.8 N·m (1.0 kgf·m 87 in·lb)
- Install the alternator outer cover (see Alternator Outer Cover Installation in the Electrical System chapter).

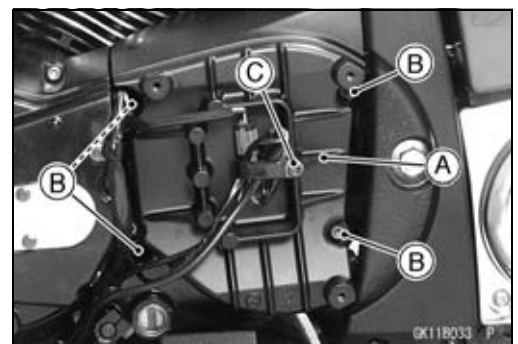

Engine Pulley Removal

- Remove the engine pulley cover (see Engine Pulley Cover Removal).
- Loosen the belt fully (see Drive Belt Deflection Adjustment in the Periodic Maintenance chapter).
- Flatten out the bent washer [A].

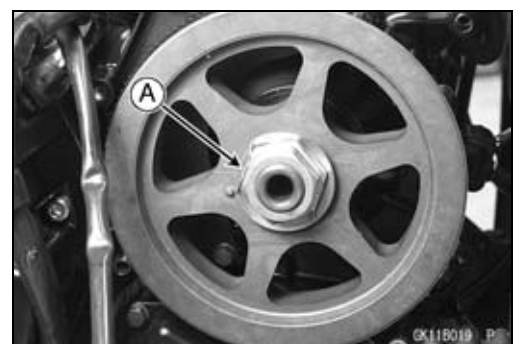

11-10 FINAL DRIVE

Pulley and Coupling

- Hold the engine pulley [A] steady with the pulley holder [B], and remove the pulley mounting nut [C].

Special Tools - Pulley Holder: 57001-1572

Grip: 57001-1591

- Pull out the engine pulley from the output shaft.

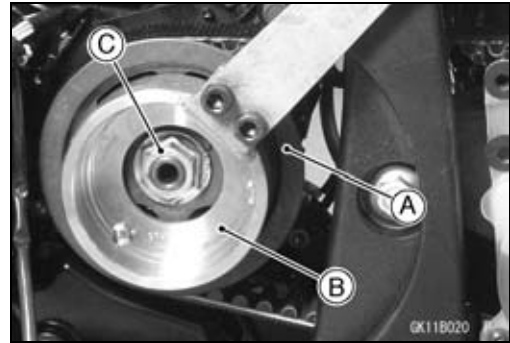

Engine Pulley Installation

- Installation is the reverse of removal. Note the following.
- Fit the grooves inside the pulley onto the splines on the output shaft.
- Replace the washer with a new one.
- Apply molybdenum disulfide grease to the threads of the output shaft and seating surface of the engine pulley mounting nut.
- Tighten:

Torque - Engine Pulley Mounting Nut: 127 N·m (13.0 kgf·m, 94 ft·lb)

Special Tools - Pulley Holder: 57001-1572

Grip: 57001-1591

- Bend the one side of the washer over the nut.
- Adjust the drive belt deflection (see Belt Deflection Adjustment in the Periodic Maintenance chapter).

Rear Pulley Removal

- Remove:
 - Rear Wheel (see Rear Wheel Removal in the Wheels/Tires chapter)
 - Rear Pulley Mounting Nuts [A] and Washers
 - Rear Pulley [B]

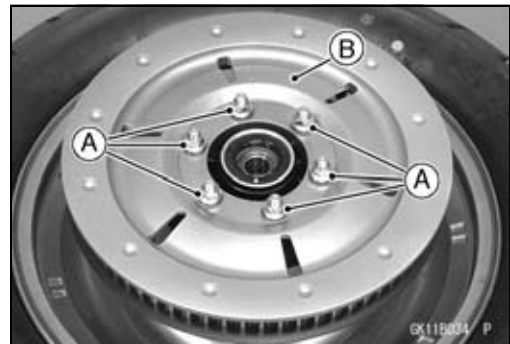

Rear Pulley Installation

- Replace the rear pulley mounting nuts with new ones.
- Install:
 - Rear Pulley
 - Washers and Rear Pulley Mounting Nuts
- Tighten:

Torque - Rear Pulley Mounting Nuts: 59 N·m (6.0 kgf·m, 44 ft·lb)

Pulley and Coupling

Rear Pulley Coupling Removal

- Remove the rear wheel (see Rear Wheel Removal in the Wheels/Tires chapter).
- Loosen the rear pulley mounting nuts [A] lightly.
- Remove the rear pulley [B] with the rear pulley coupling from the wheel [C].
- Remove the rear pulley mounting nuts and washers.
- Remove the rear pulley from the rear pulley coupling.

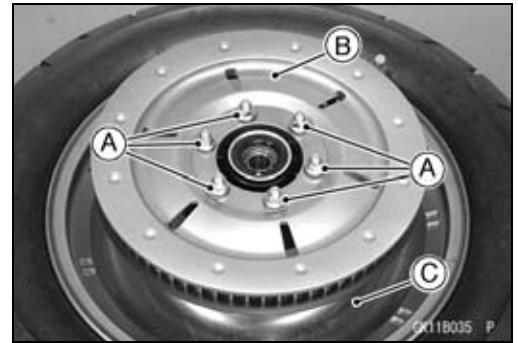

Rear Pulley Coupling Installation

- Install the coupling dampers [A] so that the projections [B] face to the outside.

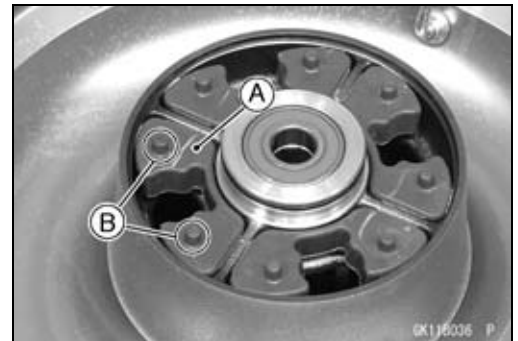

- Apply high-temperature grease to the inside [A] of the coupling bushing.
- Install the sleeve [B].
- Install the coupling on the coupling dampers.

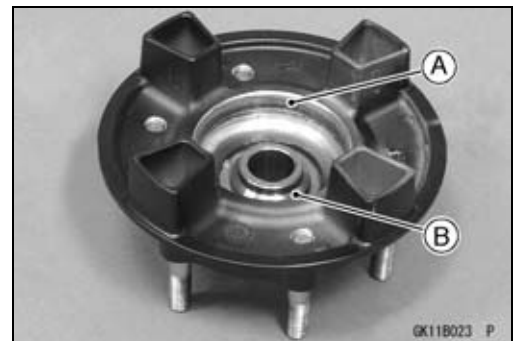

Pulley Wear Inspection

- Visually inspect the engine and rear pulley teeth for wear and damage.
- ★ If the teeth are worn, damaged, or loss of the chrome plating exists, replace the pulley, and inspect the drive belt wear (see Drive Belt Wear and Damage Inspection in the Periodic Maintenance chapter).

Engine Pulley [A]
Rear Pulley [B]



NOTE

○ If the pulley requires replacement, the belt is probably worn also. Whenever replacing the pulley, inspect the belt.

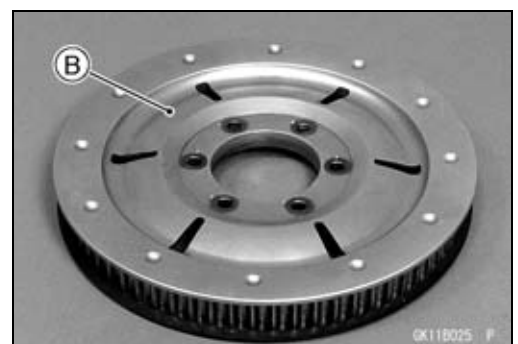

11-12 FINAL DRIVE

Pulley and Coupling

Coupling Bearing Removal

- Remove:
 - Rear Pulley Coupling (see Rear Pulley Coupling Removal)
 - Sleeve [A]



- Remove:
 - Collar [A]
 - Grease Seal [B]

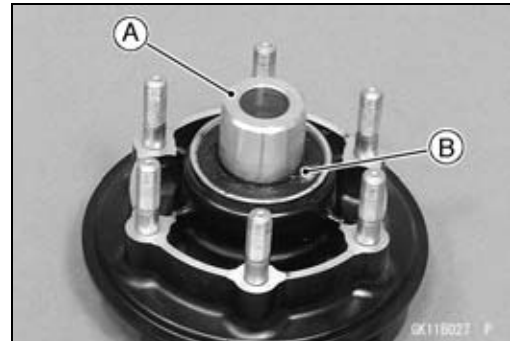

- Remove the circlip [A].
Special Tool - Inside Circlip Pliers [B]: 57001-143
- Remove the ball bearing [C].
Special Tool - Oil Seal & Bearing Remover: 57001-1058

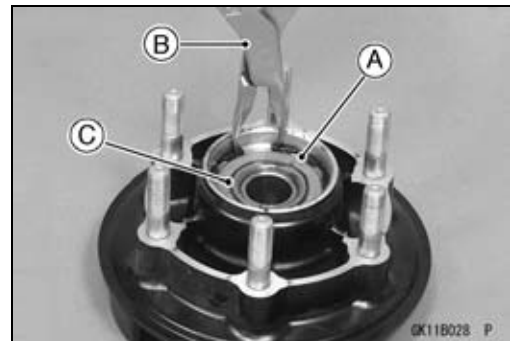

Coupling Bearing Installation

- Press the new ball bearing until it is bottomed.
Special Tool - Bearing Driver Set: 57001-1129
- Install the new circlip.
- **Special Tool - Inside Circlip Pliers: 57001-143**
- Replace the grease seal with a new one.
- Press the seal in until the face of the seal is level with the end of the grease seal hole.
Special Tool - Bearing Driver Set: 57001-1129
- Apply high-temperature grease to the grease seal lip.
- Install the collar.

Pulley and Coupling

Coupling Bearing Inspection

Since the coupling bearing [A] is made to extremely close tolerances, the clearance cannot normally be measured.

- Spin it by hand to check its condition.
- ★ If it is noisy, does not spin smoothly, or has any rough spots, it must be replaced.

NOTE

○ Since the coupling bearing are packed with grease and sealed, lubricate is not required.

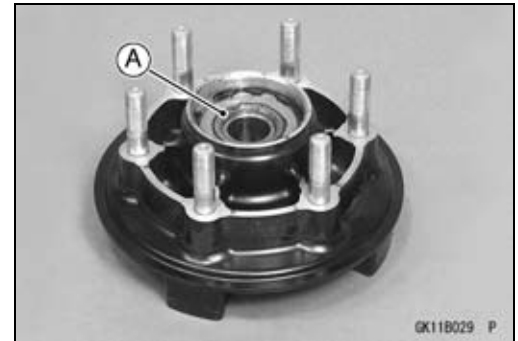

Rubber Damper Inspection

- Remove the rear wheel (see Rear Wheel Removal in the Wheels/Tires chapter).
- Remove the rear wheel coupling and inspect the rubber dampers [A].
- Replace the damper if it appears damaged or deteriorated.

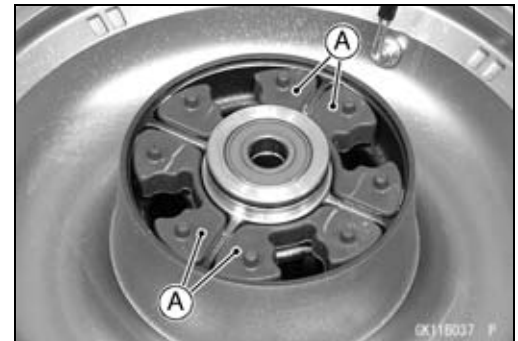

11-14 FINAL DRIVE

Belt Adjuster

Belt Adjuster Removal

- Remove the left and right belt adjuster locknuts [A] and belt adjuster nuts [B].
- Remove the belt adjuster [C] from the swingarm.

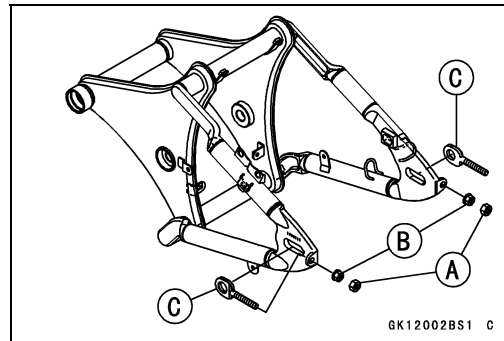

Belt Adjuster Installation

- Insert the left and right belt adjuster [A] into the swingarm facing its machined surface [B] outward.

NOTICE

Wrong installation of belt adjuster may cause the failure of drive components.

- Install the left and right belt adjuster nuts and belt adjuster locknuts.

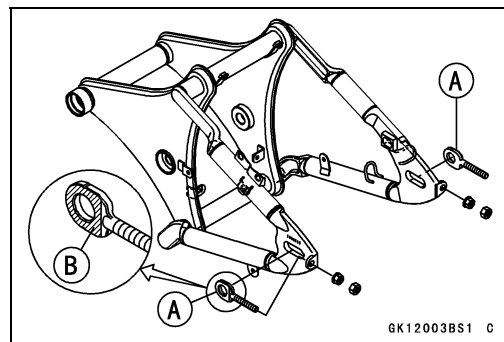

Brakes

Table of Contents

| | |
|--|-------|
| Exploded View..... | 12-2 |
| Specifications | 12-6 |
| Special Tool | 12-7 |
| Brake Lever, Brake Pedal..... | 12-8 |
| Brake Lever Position Adjustment..... | 12-8 |
| Brake Pedal Position Inspection | 12-8 |
| Brake Pedal Position Adjustment..... | 12-8 |
| Brake Pedal Removal | 12-8 |
| Brake Pedal Installation | 12-9 |
| Calipers | 12-10 |
| Front Caliper Removal | 12-10 |
| Rear Caliper Removal..... | 12-10 |
| Caliper Installation | 12-10 |
| Front Caliper Disassembly..... | 12-10 |
| Front Caliper Assembly..... | 12-10 |
| Rear Caliper Disassembly | 12-11 |
| Rear Caliper Assembly | 12-11 |
| Caliper Fluid Seal Damage Inspection..... | 12-11 |
| Caliper Dust Boot and Friction Boot Damage Inspection..... | 12-11 |
| Caliper Piston and Cylinder Damage Inspection | 12-11 |
| Caliper Holder Shaft Wear Inspection..... | 12-11 |
| Brake Pads..... | 12-12 |
| Front Brake Pad Removal..... | 12-12 |
| Front Brake Pad Installation..... | 12-12 |
| Rear Brake Pad Removal | 12-12 |
| Rear Brake Pad Installation | 12-13 |
| Brake Pad Wear Inspection | 12-13 |
| Master Cylinder | 12-14 |
| Front Master Cylinder Removal | 12-14 |
| Front Master Cylinder Installation | 12-14 |
| Rear Master Cylinder Removal..... | 12-15 |
| Rear Master Cylinder Installation..... | 12-15 |
| Front Master Cylinder Disassembly | 12-15 |
| Rear Master Cylinder Disassembly..... | 12-15 |
| Master Cylinder Assembly | 12-15 |
| Master Cylinder Inspection | 12-16 |
| Brake Discs | 12-17 |
| Brake Disc Removal | 12-17 |
| Brake Disc Installation | 12-17 |
| Brake Disc Wear Inspection..... | 12-17 |
| Brake Disc Warp Inspection..... | 12-17 |
| Brake Fluid | 12-18 |
| Brake Fluid Level Inspection..... | 12-18 |
| Brake Fluid Change | 12-18 |
| Brake Line Bleeding..... | 12-18 |
| Brake Hoses | 12-21 |
| Brake Hose Removal/Installation..... | 12-21 |
| Brake Hose Inspection..... | 12-21 |

12-2 BRAKES

Exploded View

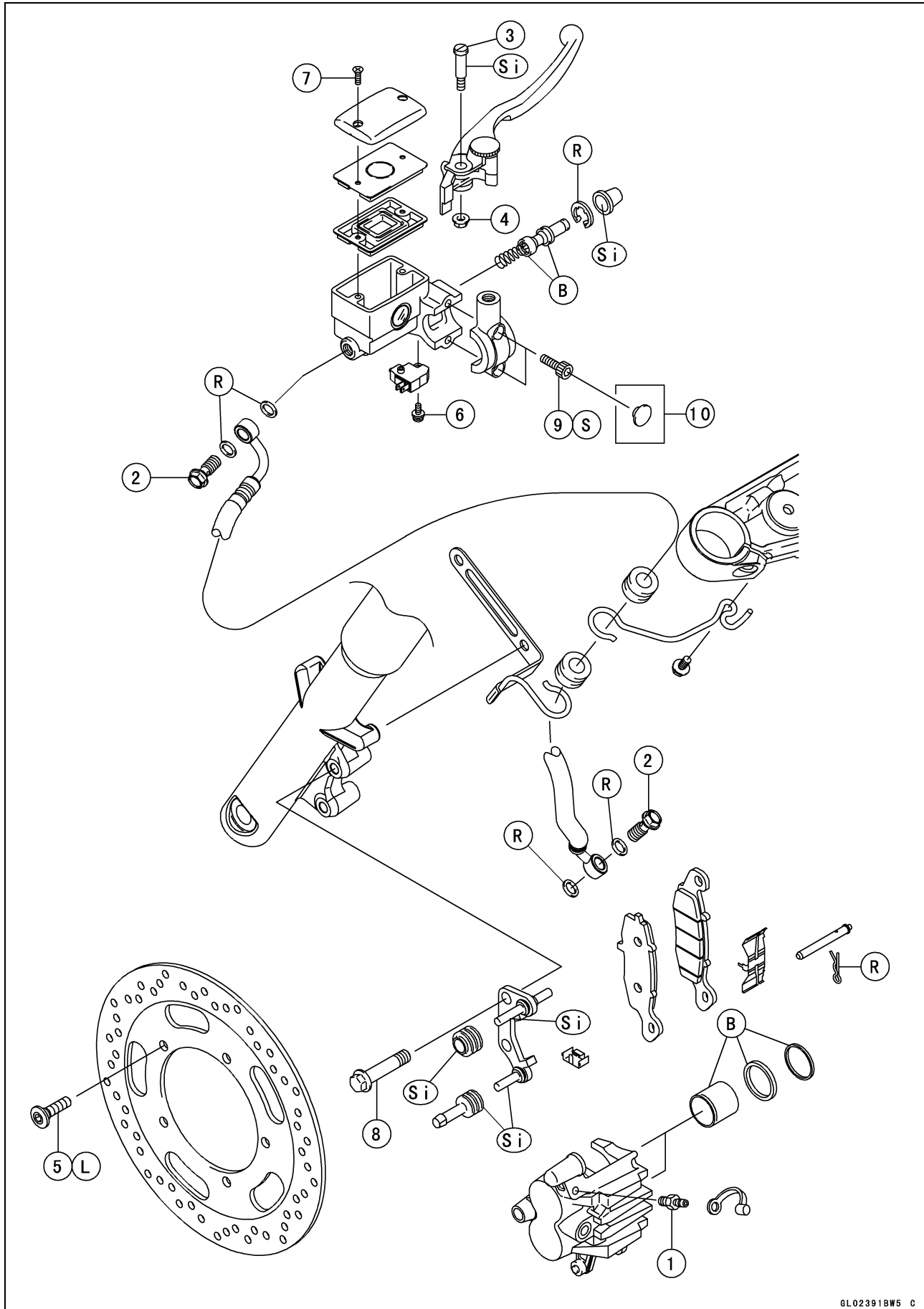

GL023918W5 C

Exploded View

| No. | Fastener | Torque | | | Remarks |
|-----|-----------------------------------|--------|-------|----------|---------|
| | | N·m | kgf·m | ft·lb | |
| 1 | Bleed Valve | 7.8 | 0.80 | 69 in·lb | |
| 2 | Brake Hose Banjo Bolts | 25 | 2.5 | 18 | |
| 3 | Brake Lever Pivot Bolt | 1.0 | 0.10 | 9 in·lb | Si |
| 4 | Brake Lever Pivot Bolt Locknut | 5.9 | 0.60 | 52 in·lb | |
| 5 | Front Brake Disc Mounting Bolts | 27 | 2.8 | 20 | L |
| 6 | Front Brake Light Switch Screw | 1.2 | 0.12 | 11 in·lb | |
| 7 | Front Brake Reservoir Cap Screws | 1.5 | 0.15 | 13 in·lb | |
| 8 | Front Caliper Mounting Bolts | 34 | 3.5 | 25 | |
| 9 | Front Master Cylinder Clamp Bolts | 8.8 | 0.90 | 78 in·lb | S |

10. VN900C7 ~ C9

B: Apply brake fluid.

L: Apply a non-permanent locking agent.

R: Replacement Parts

S: Follow the specified tightening sequence.

Si: Apply silicone grease (ex. PBC grease).

12-4 BRAKES

Exploded View

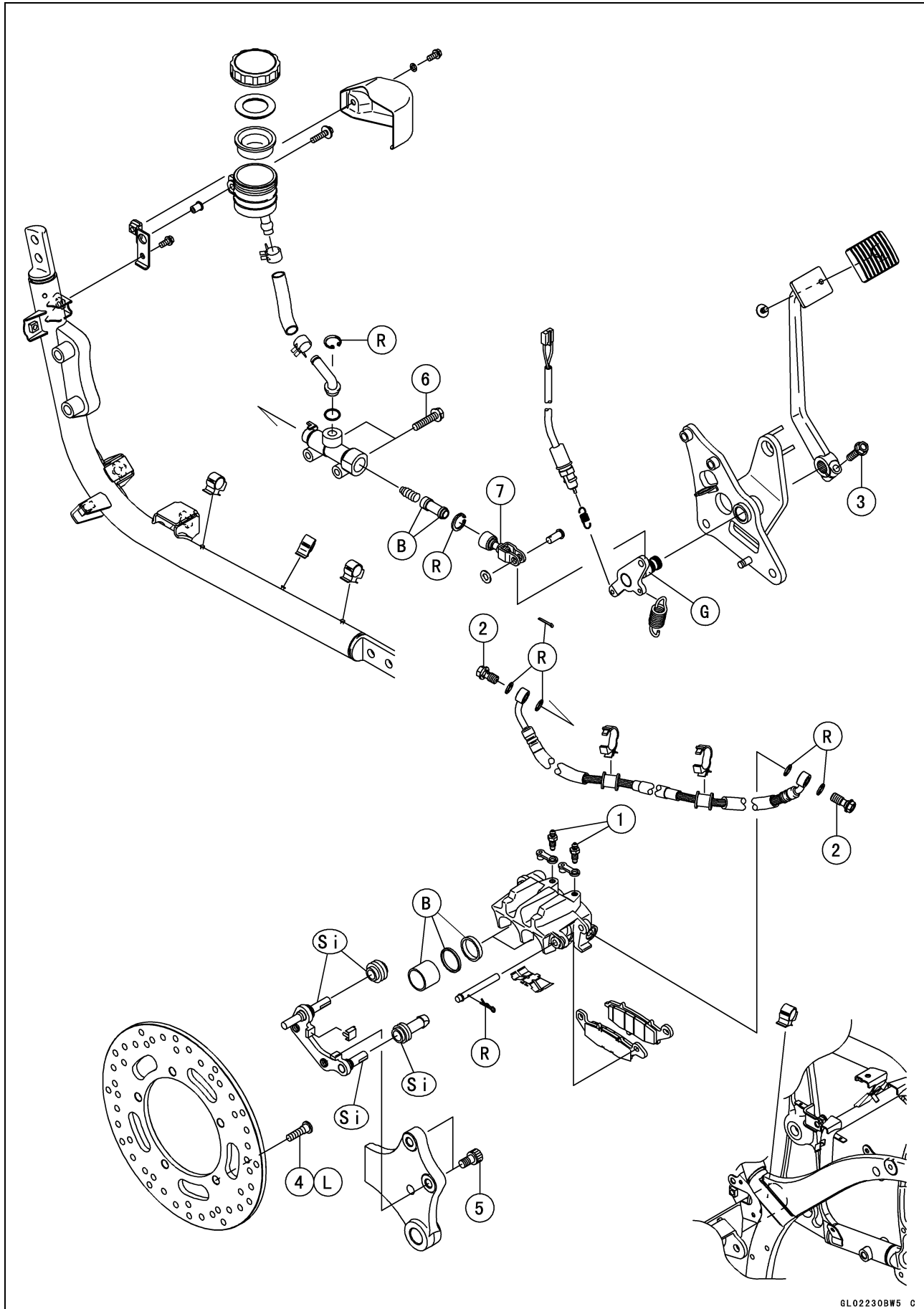

GL022308W5 C

Exploded View

| No. | Fastener | Torque | | | Remarks |
|-----|---------------------------------------|--------|-------|----------|---------|
| | | N·m | kgf·m | ft·lb | |
| 1 | Bleed Valves | 7.8 | 0.80 | 69 in·lb | |
| 2 | Brake Hose Banjo Bolts | 25 | 2.5 | 18 | |
| 3 | Brake Pedal Clamp Bolt | 25 | 2.5 | 18 | |
| 4 | Rear Brake Disc Mounting Bolts | 27 | 2.8 | 20 | L |
| 5 | Rear Caliper Mounting Bolts | 34 | 3.5 | 25 | |
| 6 | Rear Master Cylinder Mounting Bolts | 25 | 2.5 | 18 | |
| 7 | Rear Master Cylinder Push Rod Locknut | 17 | 1.7 | 12 | |

B: Apply brake fluid.

G: Apply grease.

L: Apply a non-permanent locking agent.

R: Replacement Parts

Si: Apply silicone grease (ex. PBC grease).

12-6 BRAKES

Specifications

| Item | Standard | Service Limit |
|---------------------------------|---|-----------------------|
| Brake Lever, Brake Pedal | | |
| Brake Lever Position | 5-way adjustable (to suit rider) | — — — |
| Brake Lever Free Play | Non-adjustable | — — — |
| Pedal Free Play | Non-adjustable | — — — |
| Pedal Position | About 105 mm (4.13 in.) (height from pedal top to footpeg top) | — — — |
| Brake Pads | | |
| Lining Thickness: | | |
| Front | 4.5 mm (0.18 in.) | 1 mm (0.04 in.) |
| Rear | 7.0 mm (0.28 in.) | 1 mm (0.04 in.) |
| Brake Discs | | |
| Thickness: | | |
| Front | 4.8 ~ 5.2 mm (0.19 ~ 0.20 in.) | 4.5 mm (0.18 in.) |
| Rear | 6.8 ~ 7.2 mm (0.27 ~ 0.28 in.) | 6.0 mm (0.24 in.) |
| Runout | TIR 0.1 mm (0.004 in.) or less | TIR 0.3 mm (0.01 in.) |
| Brake Fluid | | |
| Grade | DOT4 | — — — |

Special Tool

Inside Circlip Pliers:

57001-143

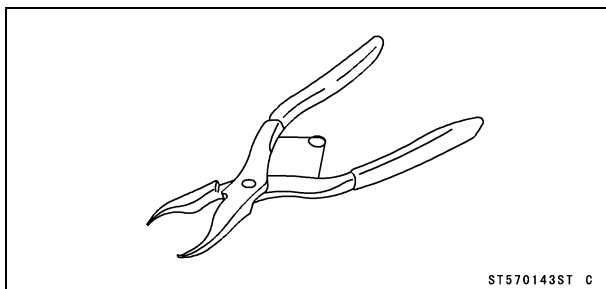

12-8 BRAKES

Brake Lever, Brake Pedal

Brake Lever Position Adjustment

The brake lever adjuster has 5 positions so that the brake lever position can be adjusted to suit the operator's hand.

- Push the lever forward and turn the adjuster [A] to align the number with the arrow mark [B] on the lever holder.
- The distance from the grip to the lever is minimum at number 5 and maximum at number 1.

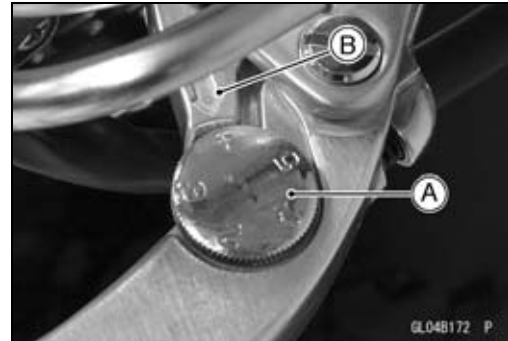

Brake Pedal Position Inspection

- Check that the brake pedal [A] is in the correct position.

Pedal Position

Standard: About 105 mm (4.13 in.) [B] (height from pedal top to footpeg top [C])

- ★ If it is incorrect, adjust the brake pedal position.

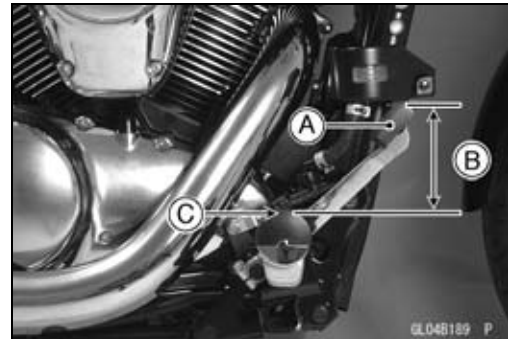

Brake Pedal Position Adjustment

NOTE

- Usually it's not necessary to adjust the pedal position, but always adjust it when push rod locknut has been loosened.
- If the push rod length cannot be adjusted by turning the clevis, the brake pedal may be deformed or incorrectly installed.

- Loosen the locknut [A] and turn the push rod with the hex head [B] to achieve the correct pedal position.
- ★ If the length [C] is 70 ± 1 mm (2.8 ± 0.04 in.), the pedal position will be within the standard range.

- Tighten:

Torque - Rear Master Cylinder Push Rod Locknut: 17 N·m (1.7 kgf·m, 12 ft·lb)

- Check the brake light switch operation (see Brake Light Switch Operation Inspection in the Periodic Maintenance chapter).



Brake Pedal Removal

- Remove:
 - Bolts [A]
 - Cover [B]
 - Brake Pedal Clamp Bolt [C]
 - Brake Pedal [D]
 - Right Footpeg Bracket Bolts [E]
 - Rear Master Cylinder Mounting Bolts [F]

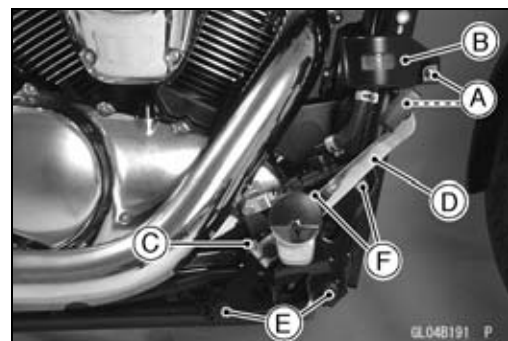

Brake Lever, Brake Pedal

- Remove:
 - Brake Pedal Return Spring [A]
 - Brake Switch Return Spring [B]
 - Cotter Pin [C]
 - Joint Pin [D]
 - Brake Lever [E]

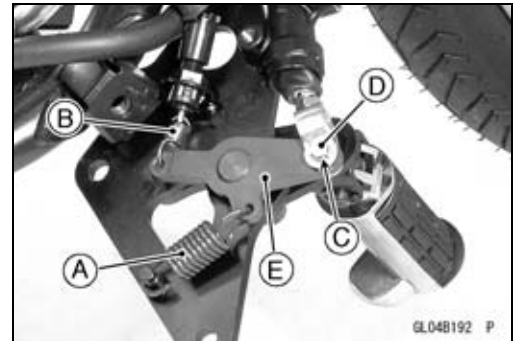

Brake Pedal Installation

- Apply grease to the brake pedal shaft.
- Install:
 - Brake Pedal Return Spring
 - Brake Switch Return Spring
- Install the brake pedal [A] so that the punched mark on the pedal is aligned [B] with the punched mark on the brake lever [C].
- Tighten:
 - Torque - Brake Pedal Clamp Bolt: 25 N·m (2.5 kgf·m, 18 ft·lb)**
 - Footpeg Bracket Bolts (Front): 34 N·m (3.5 kgf·m, 25 ft·lb)**
 - Rear Master Cylinder Mounting Bolts: 25 N·m (2.5 kgf·m, 18 ft·lb)**
- Check the brake for proper braking power, no brake drag, and no fluid leakage.

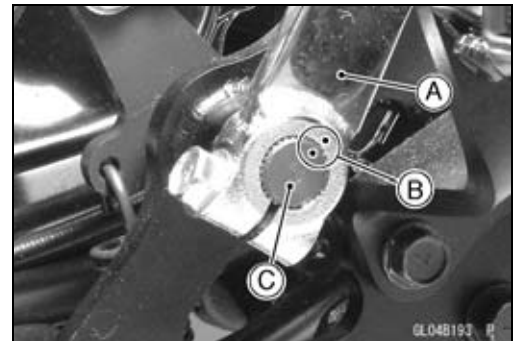

⚠ WARNING

After servicing, it takes several applications of the brake pedal before the brake pads contact the disc, which could result in increased stopping distance and cause an accident resulting in injury or death. Do not attempt to ride the motorcycle until a firm brake pedal is obtained by pumping the pedal until the pads are against the disc.

- Check the brake pedal position (see Brake Pedal Position Inspection).

12-10 BRAKES

Calipers

Front Caliper Removal

- Loosen the banjo bolt [A] at the brake hose lower end, and tighten it loosely.
- Unscrew the caliper mounting bolts [B].
- Take off the caliper [C] from the disc.
- Unscrew the banjo bolt, and disconnect the brake hose from the caliper.

NOTICE

Immediately wash away any brake fluid that spills.

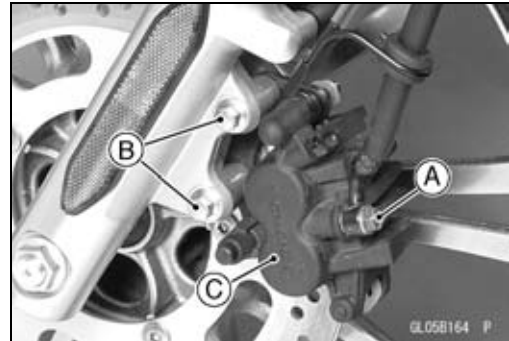

Rear Caliper Removal

- Loosen the banjo bolt [A] at the brake hose lower end, and tighten it loosely.
- Unscrew the caliper mounting bolts [B].
- Take off the caliper [C] from the disc.
- Unscrew the banjo bolt, and disconnect the brake hose from the caliper.

NOTICE

Immediately wash away any brake fluid that spills.

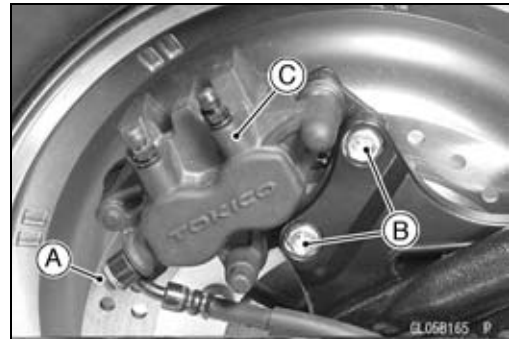

Caliper Installation

- Install the caliper and brake hose lower end.
- Replace the washer on each side of hose fitting with new ones.
- Tighten:
 - Torque - Caliper Mounting Bolts:**
 - Front: 34 N·m (3.5 kgf·m, 25 ft·lb)
 - Rear: 34 N·m (3.5 kgf·m, 25 ft·lb)
 - Brake Hose Banjo Bolts: 25 N·m (2.5 kgf·m, 18 ft·lb)**
- Check the fluid level in the brake reservoirs (see Brake Fluid Level Inspection in the Periodic Maintenance chapter).
- Bleed the brake line (see Brake Line Bleeding).
- Check the brake for good braking power, no brake drag, and no fluid leakage.

⚠ WARNING

After servicing, it takes several applications of the brake lever or pedal before the brake pads contact the disc, which could result in increased stopping distance and cause an accident resulting in injury or death. Do not attempt to ride the motorcycle until a firm brake lever or pedal is obtained by pumping the lever or pedal until the pads are against the disc.

Front Caliper Disassembly

- Refer to the Caliper Rubber Parts Replacement in the Periodic Maintenance chapter.

Front Caliper Assembly

- Refer to the Caliper Rubber Parts Replacement in the Periodic Maintenance chapter.

Calipers

Rear Caliper Disassembly

- Refer to the Caliper Rubber Parts Replacement in the Periodic Maintenance chapter.

Rear Caliper Assembly

- Refer to the Caliper Rubber Parts Replacement in the Periodic Maintenance chapter.

Caliper Fluid Seal Damage Inspection

The fluid seal (piston seal) [A] is placed around the piston to maintain clearance between the pad and the disc. If the seal is in a poor condition, it could lead the pad to wear excessively or the brake to drag, which may cause the temperature of the discs or the brake fluid to increase.

- Replace the fluid seal if it exhibits any of the conditions listed below.
 - Brake fluid leakage around the pad.
 - Brakes overheat.
 - Considerable difference in inner and outer pad wear.
 - Seal and piston are stuck together.
- ★ If the fluid seal is replaced, replace the dust seal [B] as well. Also, replace all seals every other time the pads are changed.
 - Front Caliper [G]
 - Rear Caliper [H]

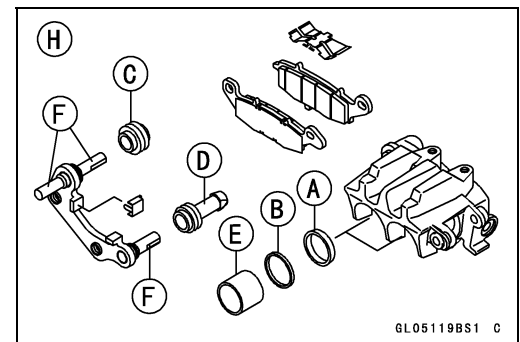
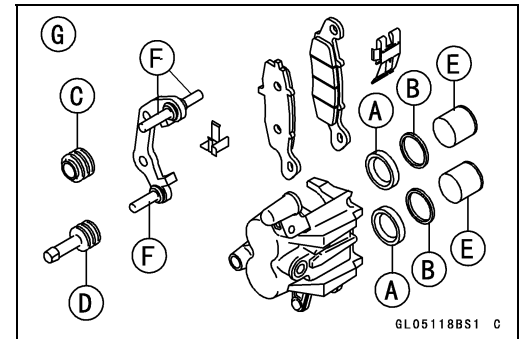

Caliper Dust Boot and Friction Boot Damage Inspection

- Check that the dust boot [C] and friction boot [D] are not cracked, worn, swollen, or otherwise damaged.
- If they show any damage, replace it.

Caliper Piston and Cylinder Damage Inspection

- Visually inspect the piston [E] and cylinder surfaces.
- ★ Replace the caliper if the cylinder and piston are badly scored or rusty.

Caliper Holder Shaft Wear Inspection

The caliper body must slide smoothly on the caliper holder shafts. If the body does not slide smoothly, one pad will wear more than the other, and constant drag on the disc may cause the temperature of the discs or the brake fluid to increase.

- Visually inspect that the caliper holder shafts [F] are not badly worn or bent.
- ★ If the caliper holder shafts are damaged, replace the entire caliper assembly.

12-12 BRAKES

Brake Pads

Front Brake Pad Removal

- Remove the front caliper with the hose installed (see Front Caliper Removal).
- Remove:
 - Snap Pin [A]
 - Pad Pin [B]

- Remove the jaw side pad [A], and then remove the piston side pad [B].
 - Jaw [C]

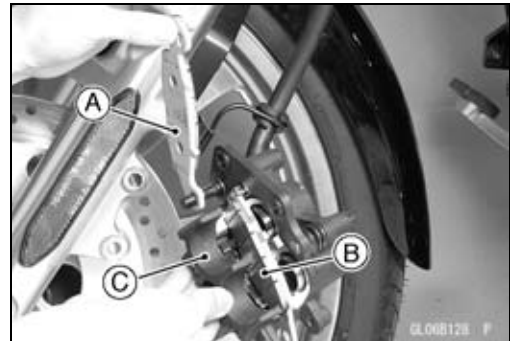
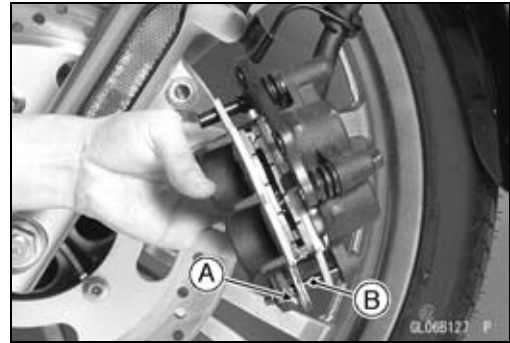

Front Brake Pad Installation

- Before installation, clean the pads with a high flash-point solvent.
- Push the caliper pistons in by hand as far as they will go.
- Install the brake pads.
- Install the pad pin and snap pin [A]. The snap pin must be "outside" of the pads.

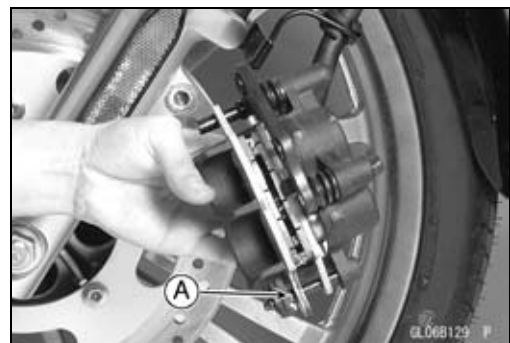

⚠ WARNING

After servicing, it takes several applications of the brake lever before the brake pads contact the disc, which could result in increased stopping distance and cause an accident resulting in injury or death. Do not attempt to ride the motorcycle until a firm brake lever is obtained by pumping the lever until the pads are against the disc.

Rear Brake Pad Removal

- Remove the rear caliper with the hose installed (see Rear Caliper Removal).
- Remove:
 - Snap Pin [A]
 - Pad Pin [B]



Brake Pads

- Remove the jaw side pad [A], and then remove the piston side pad [B].
Jaw [C]

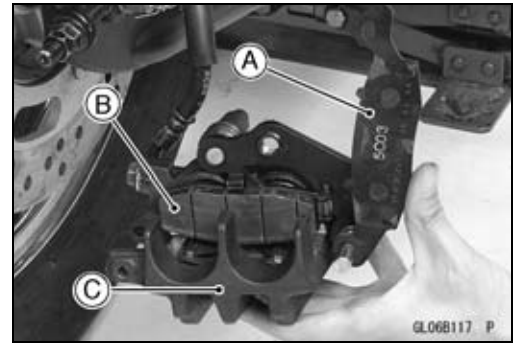

Rear Brake Pad Installation

- Before installation, clean the pads with a high flash-point solvent.
- Push the caliper pistons [A] in by hand as far as they will go.
- Install the brake pads.
- Be sure to install the snap pin for the caliper.

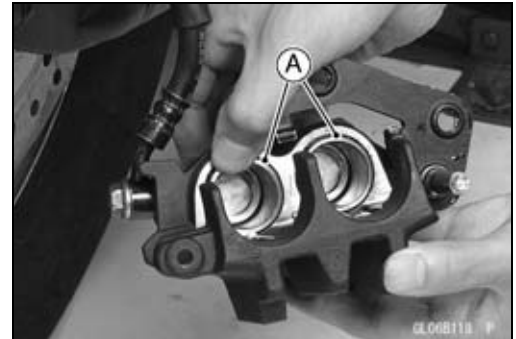

⚠ WARNING

After servicing, it takes several applications of the brake pedal before the brake pads contact the disc, which could result in increased stopping distance and cause an accident resulting in injury or death. Do not attempt to ride the motorcycle until a firm brake pedal is obtained by pumping the pedal until the pads are against the disc.

Brake Pad Wear Inspection

- Refer to the Brake Pad Wear Inspection in the Periodic Maintenance chapter.

12-14 BRAKES

Master Cylinder

Front Master Cylinder Removal

- Disconnect the front brake light switch connector [A].
- Remove the banjo bolt [B] to disconnect the brake hose from the master cylinder (see Brake Hose Replacement in the Periodic Maintenance chapter).
- Remove the clamp bolt caps [C] (VN900C7 ~ C9).
- Unscrew the clamp bolts, and take off the master cylinder as an assembly with the reservoir, brake lever and brake switch installed.

NOTICE

Immediately wash away any brake fluid that spills.

Front Master Cylinder Installation

- Set the front master cylinder [A] to match its mating surface [B] to the punched mark [C] of the handlebar.

- Tighten the upper clamp bolt [A] first, and then the lower clamp bolt [B]. There will be a gap at the lower part of the clamp after tightening.

Torque - Front Master Cylinder Clamp Bolts: 8.8 N·m (0.90 kgf·m, 78 in·lb)

- Install the clamp bolt caps (VN900C7 ~ C9).
- Use new flat washers [A] on each side of the brake hose fitting.
- Tighten the brake hose banjo bolt [B].

Torque - Brake Hose Banjo Bolts: 25 N·m (2.5 kgf·m, 18 ft·lb)

- Replenish the fluid in the reservoir, and bleed the brake line (see Brake Line Bleeding).
- Check the brake for good braking power, no brake drag, and no fluid leakage.

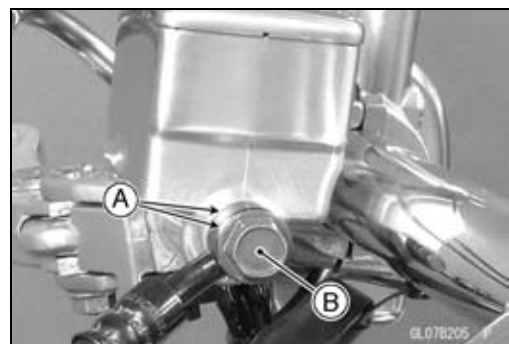
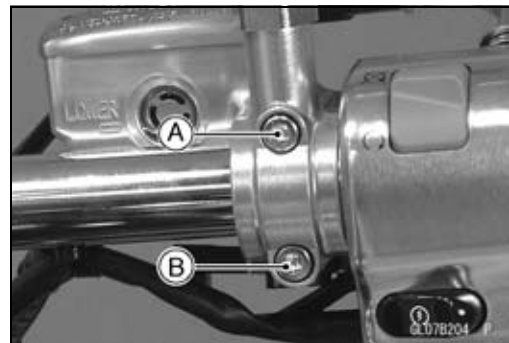
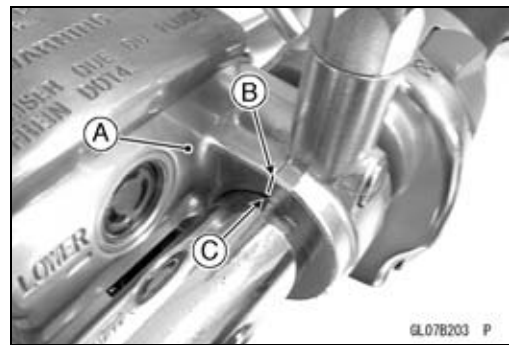
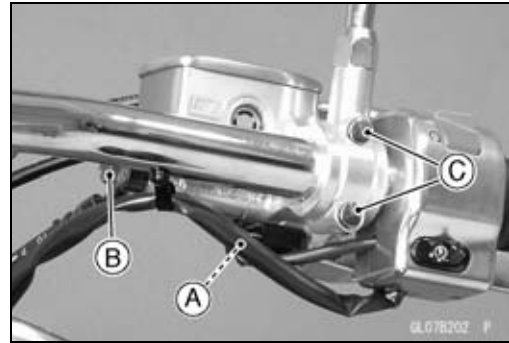

Master Cylinder

Rear Master Cylinder Removal

- Remove the brake fluid reservoir (see Brake Pedal Removal).
- Unscrew the brake hose banjo bolt [A] on the master cylinder.
- Loosen the rear master cylinder mounting bolts [B].
- Unscrew the footpeg bracket bolts [C].

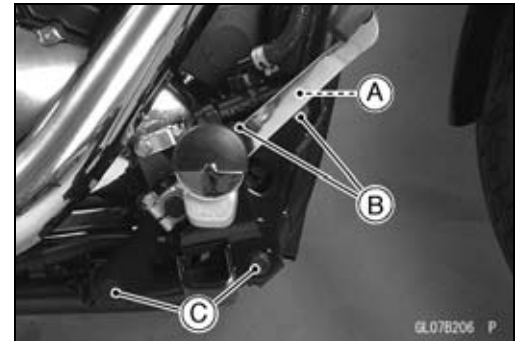

- Remove:
 - Cotter Pin [A]
 - Joint Pin [B]
 - Rear Master Cylinder Mounting Bolts [C]

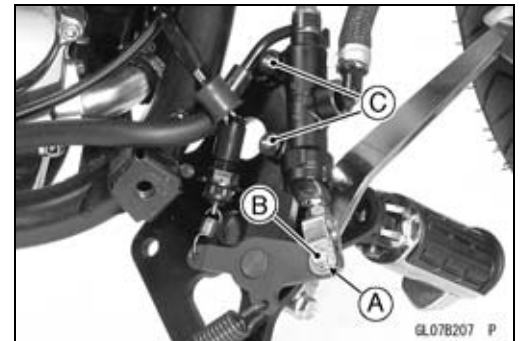

Rear Master Cylinder Installation

- Replace the cotter pin with a new one.
- Insert the cotter pin [A] to the hole of the joint pin [B] and separate [C] the cotter pin ends.
- Use a new flat washer on each side of the brake hose fitting.
- Tighten:

Torque - Footpeg Bracket Bolts (Front): 34 N·m (3.5 kgf·m, 25 ft·lb)

Rear Master Cylinder Mounting Bolts: 25 N·m (2.5 kgf·m, 18 ft·lb)

Brake Hose Banjo Bolts: 25 N·m (2.5 kgf·m, 18 ft·lb)

- Replenish the fluid in the reservoir, and bleed the brake line (see Brake Line Bleeding).
- Check the brake for good braking power, no brake drag, and no fluid leakage.

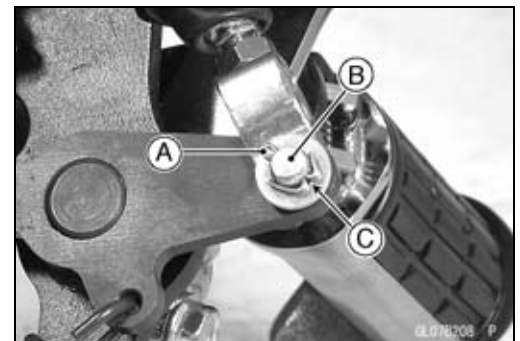

Front Master Cylinder Disassembly

- Refer to the Master Cylinder Rubber Parts Replacement in the Periodic Maintenance chapter.

Rear Master Cylinder Disassembly

- Refer to the Master Cylinder Rubber Parts Replacement in the Periodic Maintenance chapter.

Master Cylinder Assembly

- Refer to the Master Cylinder Rubber Parts Replacement in the Periodic Maintenance chapter.

12-16 BRAKES

Master Cylinder

Master Cylinder Inspection

- Disassemble the front and rear master cylinders (see Master Cylinder Rubber Parts Replacement in the Periodic Maintenance chapter).

NOTICE

Do not remove the secondary cup from the piston since removal will damage it.

- Check that there are no scratches, rust or pitting on the inner wall [A] of each master cylinder and on the outside of each piston [B].
- ★ If a master cylinder or piston shows any damage, replace them.
- Inspect the primary cup [C] and secondary cup [D].
- ★ If a cup is worn, damaged softened (rotted), or swollen, the piston assy should be replaced to renew the cups.
- ★ If fluid leakage is noted at the brake lever, the piston assy should be replaced to renew the cups.
- Check the dust covers [E] for damage.
- ★ If they are damaged, replace them.
- Check the piston return spring [F] for any damage.
- ★ If the springs are damaged, replace them.
- Check that relief port [G] and supply port [H] are not plugged.
- ★ If the relief port becomes plugged, the brake pads will drag on the disc. Blow the ports clean with compressed air.

Front Master Cylinder [J]

Rear Master Cylinder [K]

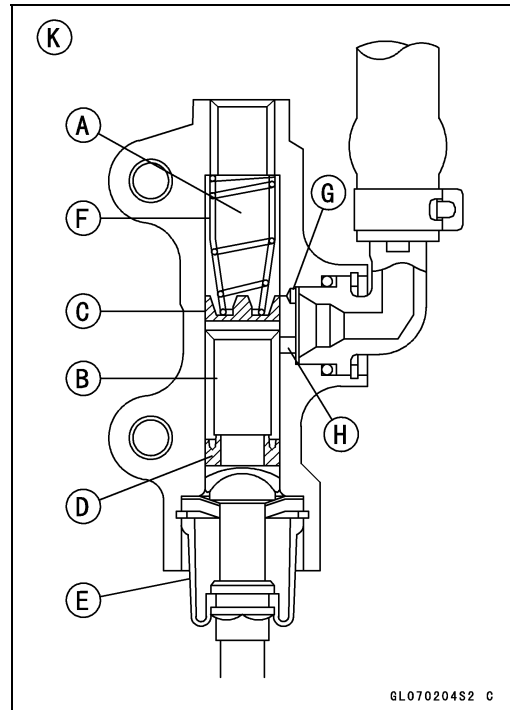
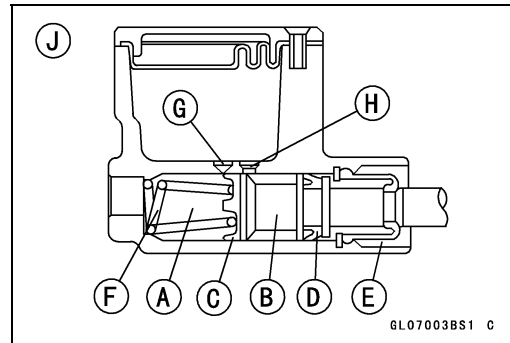

Brake Discs

Brake Disc Removal

- Remove the wheel (see Front/Rear Wheel Removal in the Wheels/Tires chapter).
- Unscrew the mounting bolts [A], and take off the disc.



Brake Disc Installation

- Install the brake disc [A] on the wheel so that the marked side [B] faces out.
- Apply a non-permanent locking agent to the threads of the brake disc mounting bolts [C].
- Tighten:

Torque - Brake Disc Mounting Bolts: 27 N·m (2.8 kgf·m, 20 ft·lb)

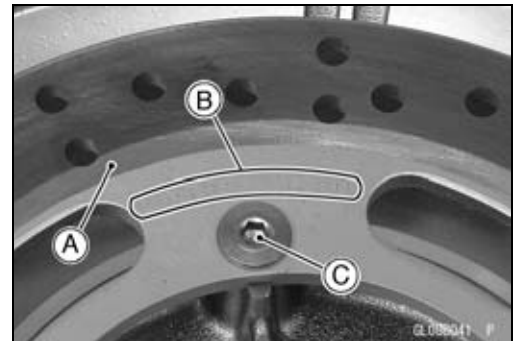

Brake Disc Wear Inspection

- Measure the thickness of each disc [A] at the point where it has worn the most.
 - ★ If the disc has worn past the service limit, replace it.
- Measuring Area [B]

Brake Discs Thickness

Standard:

Front 4.8 ~ 5.2 mm (0.19 ~ 0.20 in.)

Rear 6.8 ~ 7.2 mm (0.27 ~ 0.28 in.)

Service Limit:

Front 4.5 mm (0.18 in.)

Rear 6.0 mm (0.24 in.)

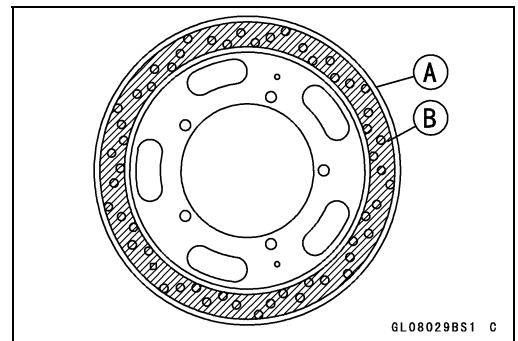

Brake Disc Warp Inspection

- Raise the wheel off the ground with jack (see Front/Rear Wheel Removal in the Wheels/Tires chapter).
- For front disc inspection, turn the handlebar fully to one side.
- Set up a dial gauge against the disc [A] as shown in the figure and measure disc runout, while turning [B] the wheel by hand.
- ★ If the runout exceeds the service limit, replace the disc.

Disc Runout

Standard: TIR 0.1 mm (0.004 in.) or less

Service Limit: TIR 0.3 mm (0.01 in.)

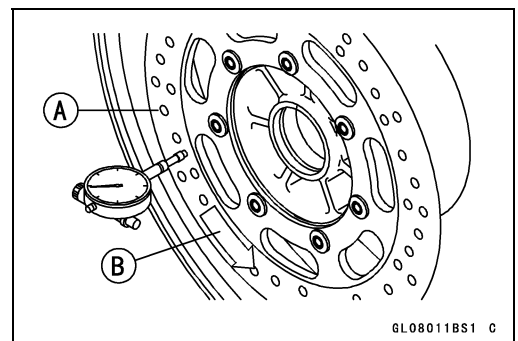

12-18 BRAKES

Brake Fluid

Brake Fluid Level Inspection

- Refer to the Brake Fluid Level Inspection in the Periodic Maintenance chapter.

Brake Fluid Change

- Refer to the Brake Fluid Change in the Periodic Maintenance chapter.

Brake Line Bleeding

The brake fluid has a very low compression coefficient so that almost all the movement of the brake lever or pedal is transmitted directly to the caliper for braking action. Air, however, is easily compressed. When air enters the brake lines, brake lever or pedal movement will be partially used in compressing the air. This will make the lever or pedal feel spongy, and there will be a loss in braking power.

⚠ WARNING

Air in the brake lines diminish braking performance and can cause an accident resulting in injury or death. If the brake lever has a soft or "spongy" feeling mushy when it is applied, there might be air in the brake lines or the brake may be defective. Do not operate the vehicle and service the brake system immediately.

NOTE

- *The procedure to bleed the front brake line is as follows. Bleeding the rear brake line is the same as for the front brake.*

- Remove the reservoir cap, and fill the reservoir with fresh brake fluid to the upper level line in the reservoir.
- Slowly pump the brake lever several times until no air bubbles can be seen rising up through the fluid from the holes [A] at the bottom of the reservoir.

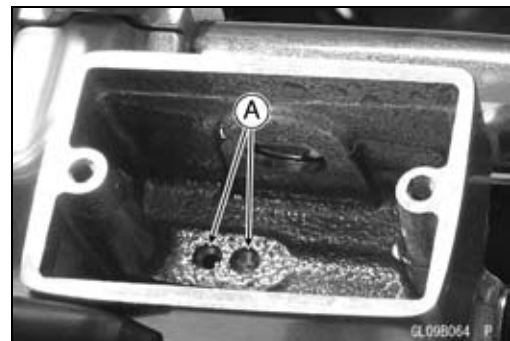

- Remove the rubber cap from the bleed valve [A] on the caliper [B].
- Attach a clear plastic hose [C] to the bleed valve, and run the other end of the hose into a container.

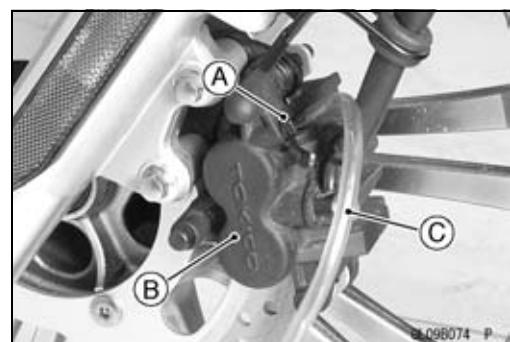

Brake Fluid

- Bleed the brake line and the caliper.
- Repeat this operation until no more air can be seen coming out into the plastic hose.
- 1. Pump the brake lever until it becomes hard, and apply the brake lever and hold it [A].
- 2. Quickly open and close [B] the bleed valve while holding the brake lever applied.
- 3. Release the brake lever [C].

NOTE

- The fluid level must be checked often during the bleeding operation and replenished with fresh brake fluid as necessary. If the fluid in the reservoir runs completely out any time during bleeding, the bleeding operation must be done over again from the beginning since air will have entered the line.
- Tap the brake hose lightly from the caliper to the reservoir for more complete bleeding.

- Remove the clear plastic hose.
- Install the diaphragm and reservoir cap.
- Tighten:

Torque - Front Brake Reservoir Cap Screws: 1.5 N·m (0.15 kgf·m, 13 in·lb)

- Follow the procedure below to install the rear brake fluid reservoir cap correctly.
- First, tighten the rear brake fluid reservoir cap [B] clockwise [C] by hand until slight resistance is felt indicating that the cap is seated on the reservoir body, then tighten the cap an additional 1/6 turn [D] while holding the brake fluid reservoir body [A].

NOTE

- For the rear brake caliper [A], bleed the brake line for two bleed valves [B].

- Tighten the bleed valves, and install the rubber cap.
- Torque - Bleed Valves: 7.8 N·m (0.80 kgf·m, 69 in·lb)**
- Check the fluid level (see Brake Fluid Level Inspection in the Periodic Maintenance chapter).
- After bleeding is done, check the brake for good braking power, no brake drag, and no fluid leakage.

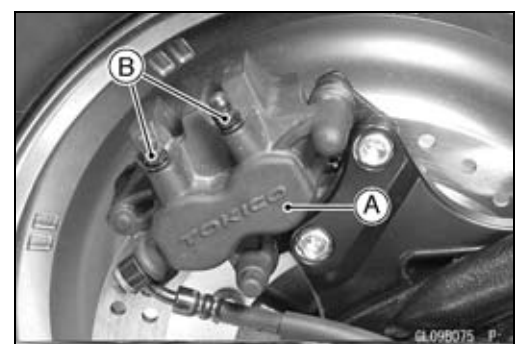
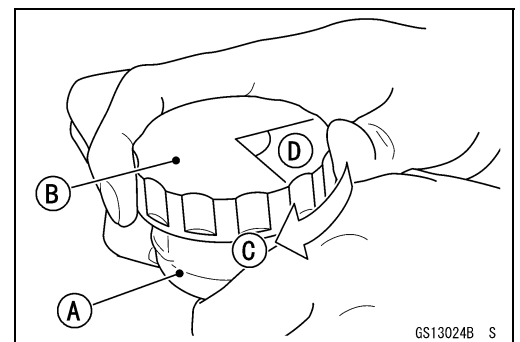
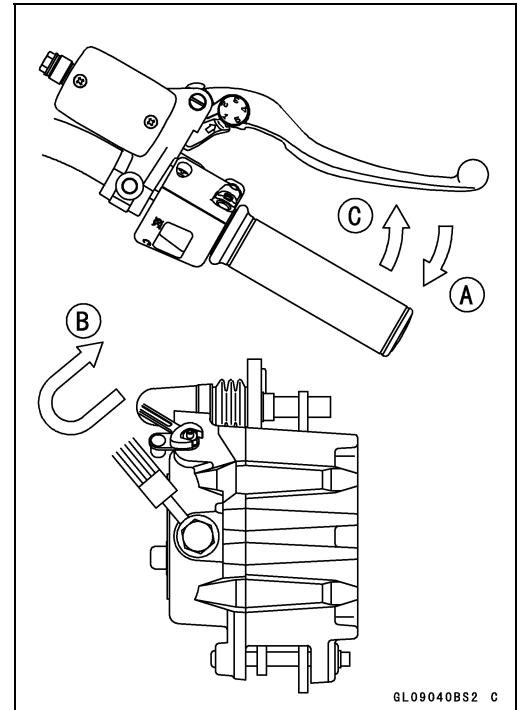

12-20 BRAKES

Brake Fluid

WARNING

When working with the disc brake, observe the precautions listed below.

- Never reuse old brake fluid.
- Do not use fluid from a container that has been left unsealed or that has been open for a long time.
- Do not mix two types and brands of fluid for use in the brake. This lowers the brake fluid boiling point and could cause the brake to be ineffective. It may also cause the rubber brake parts to deteriorate.
- Don't leave the reservoir cap off for any length of time to avoid moisture contamination of the fluid.
- Don't change the fluid in the rain or when a strong wind is blowing.
- Except for the disc pads and disc, use only disc brake fluid, isopropyl alcohol, or ethyl alcohol for cleaning of the brake parts. Do not use any other fluid for cleaning these parts. Gasoline, engine oil, or any other petroleum distillate will cause deterioration of the rubber parts. Oil spilled on any part will be difficult to wash off completely and will eventually deteriorate the rubber used in the disc brake.
- When handling the disc pads or disc, be careful that no disc brake fluid or any oil gets on them. Clean off any fluid or oil that inadvertently gets on the pads or disc with a high flash-point solvent. Do not use one which will leave an oily residue. Replace the pads with new ones if they cannot be cleaned satisfactorily.
- Brake fluid quickly ruins painted surfaces; any spilled fluid should be completely wiped up immediately.
- If any of the brake line fittings or the bleed valve is opened at any time, the **AIR MUST BE BLED FROM THE BRAKE LINE.**

Brake Hoses

Brake Hose Removal/Installation

- Refer to the Brake Hose and Pipe Replacement in the Periodic Maintenance chapter.

Brake Hose Inspection

- Refer to the Brake Hose Damage and Installation Condition Inspection in the Periodic Maintenance chapter.

Suspension

Table of Contents

| | |
|---|-------|
| Exploded View | 13-2 |
| Specifications | 13-6 |
| Special Tools | 13-7 |
| Front Fork | 13-8 |
| Front Fork Removal | 13-8 |
| Front Fork Installation | 13-8 |
| Front Fork Oil Change | 13-8 |
| Front Fork Disassembly | 13-9 |
| Front Fork Assembly | 13-11 |
| Inner Tube Inspection | 13-12 |
| Dust Seal Inspection | 13-12 |
| Fork Spring Inspection | 13-13 |
| Rear Shock Absorber | 13-14 |
| Spring Preload Adjustment | 13-14 |
| Rear Shock Absorber Removal | 13-14 |
| Rear Shock Absorber Installation | 13-15 |
| Rear Shock Absorber Inspection | 13-15 |
| Rear Shock Absorber Scrapping | 13-15 |
| Swingarm | 13-16 |
| Swingarm Removal | 13-16 |
| Swingarm Installation | 13-17 |
| Swingarm Bearing Removal | 13-17 |
| Swingarm Bearing Installation | 13-18 |
| Swingarm Bearing, Sleeve Inspection | 13-19 |
| Grease Seal and Needle Bearing Lubrication | 13-19 |
| Tie-Rod, Rocker Arm | 13-20 |
| Tie-Rod Removal | 13-20 |
| Tie-Rod Installation | 13-20 |
| Rocker Arm Removal | 13-20 |
| Rocker Arm Installation | 13-20 |
| Tie-Rod and Rocker Arm Bearing Removal | 13-21 |
| Tie-Rod and Rocker Arm Bearing Installation | 13-21 |

13-2 SUSPENSION

Exploded View

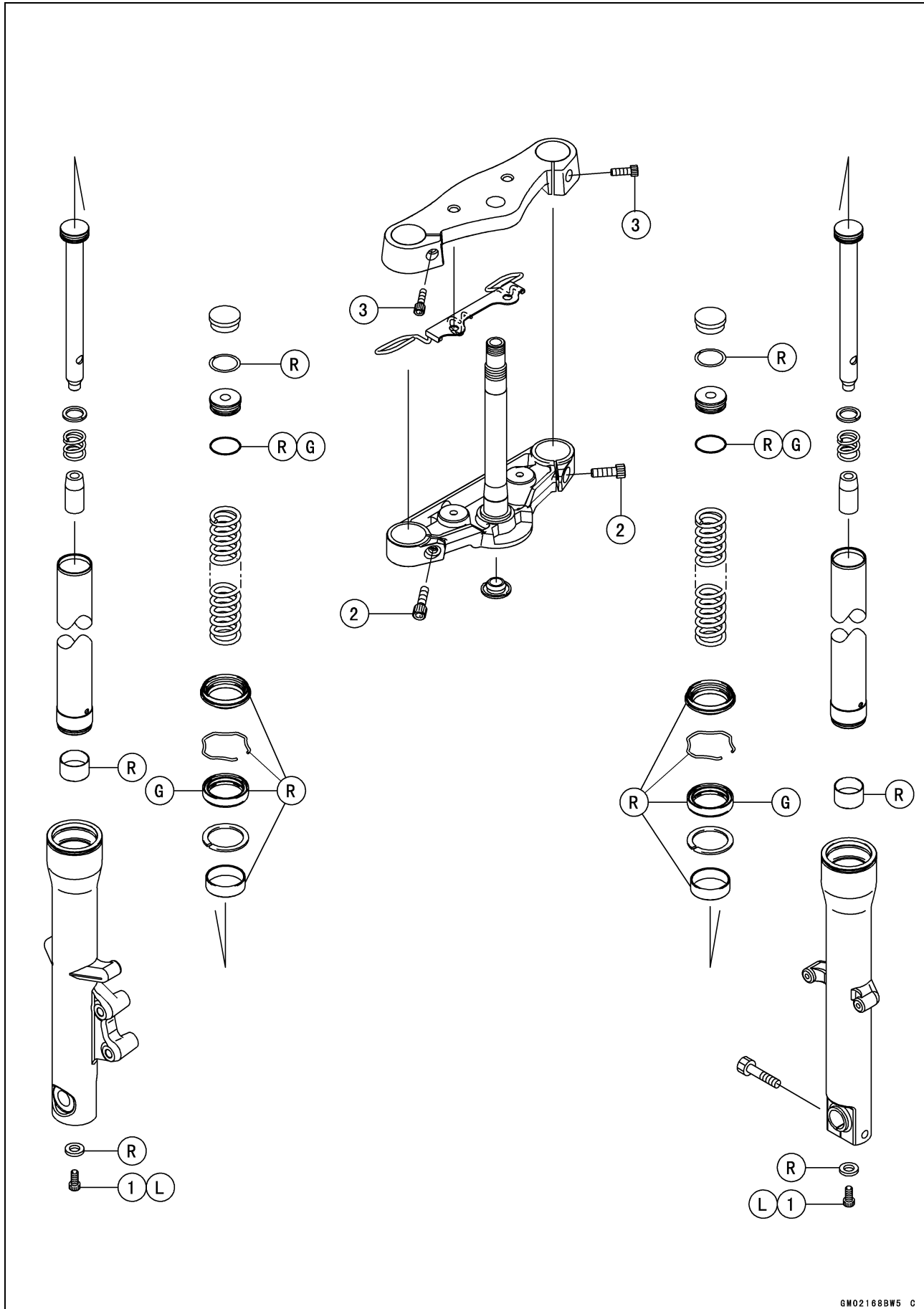

Exploded View

| No. | Fastener | Torque | | | Remarks |
|------------|--------------------------------|---------------|--------------|--------------|----------------|
| | | N·m | kgf·m | ft·lb | |
| 1 | Front Fork Bottom Allen Bolts | 20 | 2.0 | 15 | L |
| 2 | Front Fork Clamp Bolts (Lower) | 34 | 3.5 | 25 | |
| 3 | Front Fork Clamp Bolts (Upper) | 20 | 2.0 | 15 | |

G: Apply grease.

L: Apply a non-permanent locking agent.

R: Replacement Parts

13-4 SUSPENSION

Exploded View

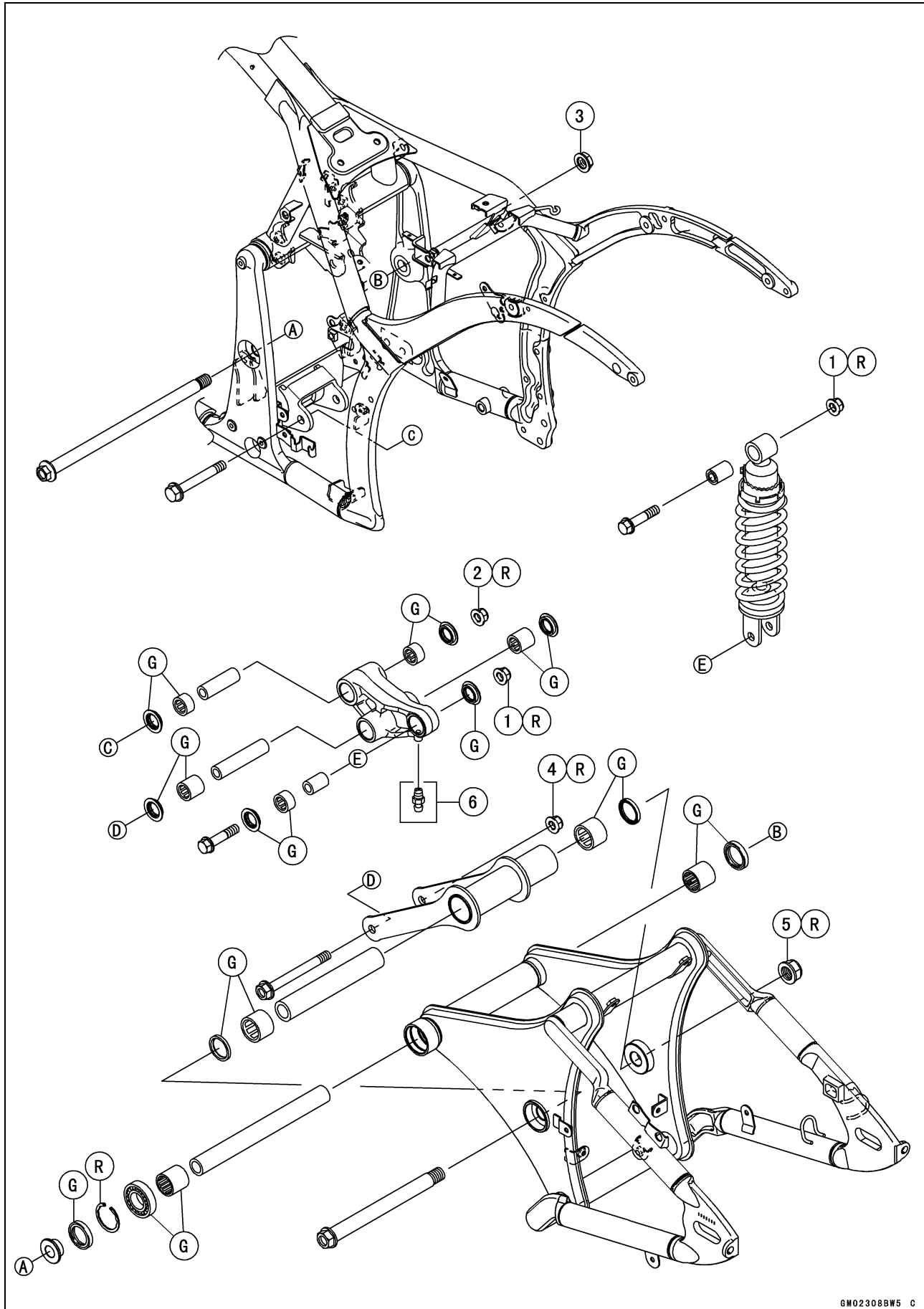

GM023088W5 C

Exploded View

| No. | Fastener | Torque | | | Remarks |
|------------|----------------------------|---------------|--------------|--------------|----------------|
| | | N·m | kgf·m | ft·lb | |
| 1 | Rear Shock Absorber Nuts | 59 | 6.0 | 44 | R |
| 2 | Rocker Arm Pivot Shaft Nut | 59 | 6.0 | 44 | R |
| 3 | Swingarm Pivot Shaft Nut | 98 | 10 | 72 | |
| 4 | Tie-Rod Nut (Lower) | 59 | 6.0 | 44 | R |
| 5 | Tie-Rod Nut (Upper) | 108 | 11.0 | 80 | R |

6. VN900C7 ~ C9

G: Apply grease.

R: Replacement Parts

13-6 SUSPENSION

Specifications

| Item | Standard |
|----------------------------------|---|
| Front Fork (Per One Unit) | |
| Fork Inner Tube Outside Diameter | 41 mm (1.6 in.) |
| Air Pressure | Atmospheric pressure (Non-adjustable) |
| Fork Spring Setting | Non-adjustable |
| Damper Setting | Non-adjustable |
| Suspension Oil | Kawasaki SS-8 or equivalent |
| Amount | Approx. 365 mL (12.3 US oz.) (when changing oil) |
| | 428 ±2.5 mL (14.5 ±0.084 US oz.) (after disassembly and completely dry) |
| Fork Oil Level | 150 ±2 mm (5.91 ±0.08 in.) (below from inner tube top with fully compressed, without fork spring) |
| Fork Spring Free Length | 527.2 mm (20.76 in.) (Service limit 517 mm (20.4 in.)) |
| Rear Shock Absorber | |
| Spring Preload | 4th position (Adjustable Range: 1st ~ 7th position) |
| Gas Pressure | 980 kPa (10 kgf/cm ² , 142 psi, Non-adjustable) |

Special Tools

Inside Circlip Pliers:
57001-143

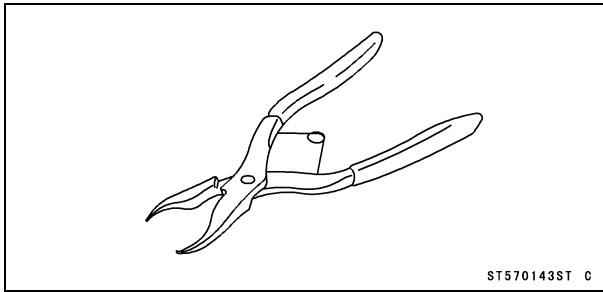

Fork Outer Tube Weight:
57001-1218

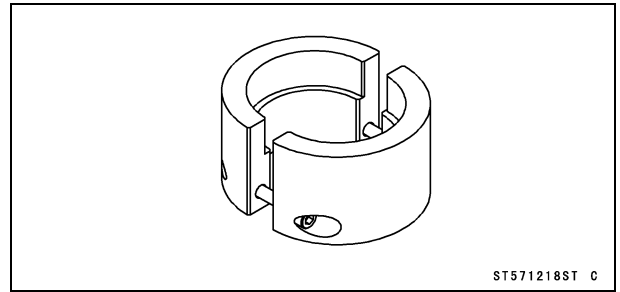

Fork Cylinder Holder Handle:
57001-183

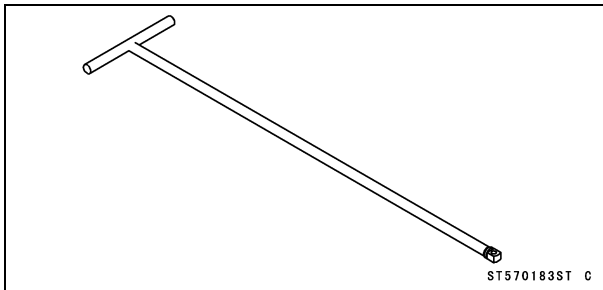

Front Fork Oil Seal Driver:
57001-1219

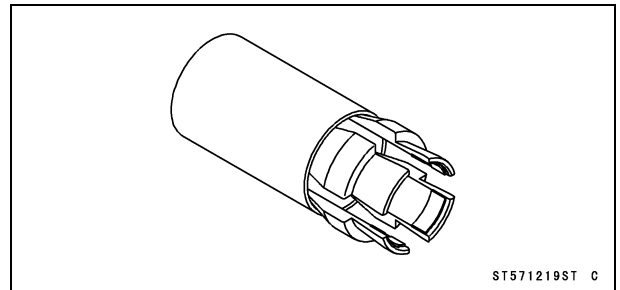

Fork Cylinder Holder Adapter:
57001-1057

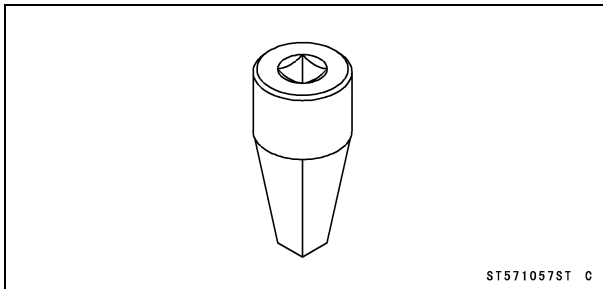

Jack:
57001-1238

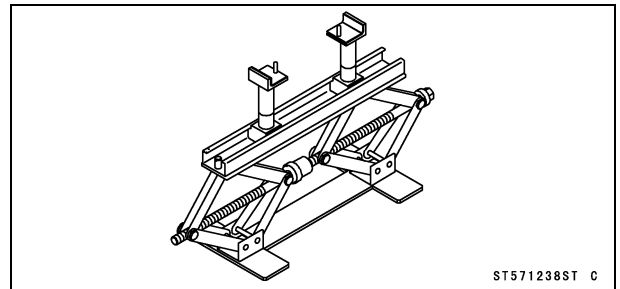

Bearing Driver Set:
57001-1129

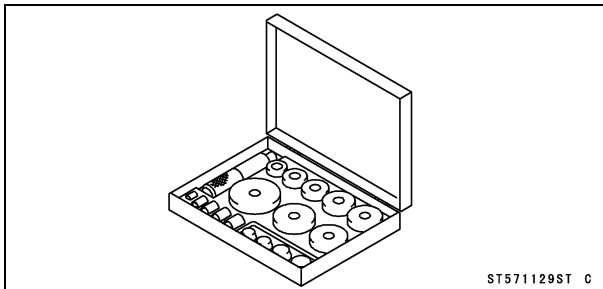

Fork Oil Level Gauge:
57001-1290

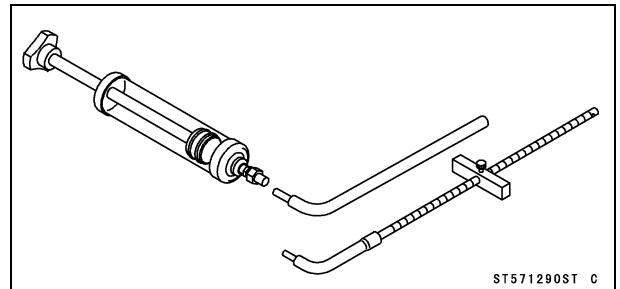

13-8 SUSPENSION

Front Fork

Front Fork Removal

- Remove:
 - Front Wheel (see Front Wheel Removal in the Wheels/Tires chapter)
 - Front Fender (see Front Fender Removal in the Frame chapter)
 - Headlight Body [A] (see Headlight Body Removal in the Electrical System chapter)
 - Turn Signal Light Lead Connectors [B] (Disconnect)
 - Turn Signal Light Bolts (Both Sides) [C]
 - Turn Signal Lights
- Loosen:
 - Upper Front Fork Clamp Bolt [A]
 - Lower Front Fork Clamp Bolt [B]
- With a twisting motion, work the fork leg down and out.

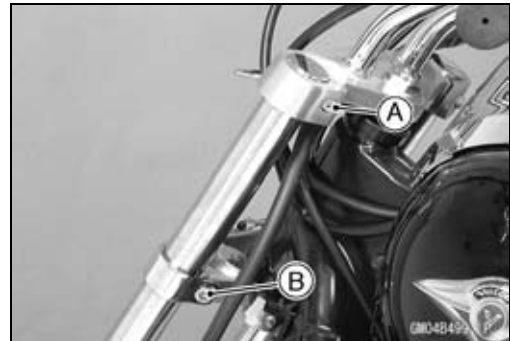
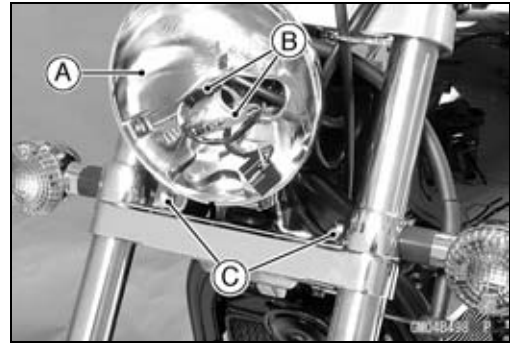

Front Fork Installation

- Install the fork so that the top end [A] of the inner tube is flush with the upper surface of the steering stem head.
- Tighten:
 - Torque - Front Fork Clamp Bolts (Lower): 34 N·m (3.5 kgf·m, 25 ft·lb)**
 - Front Fork Clamp Bolts (Upper): 20 N·m (2.0 kgf·m, 15 ft·lb)**
- Install the removed parts (see appropriate chapters).



Front Fork Oil Change

- Remove:
 - Front Fork (see Front Fork Removal)
 - Top Cap
 - Hold the outer tube vertically in a vise.
 - Push the top plug [A] down to remove the plug retaining ring [B], and then remove the plug.
-
- Remove the fork spring [A].

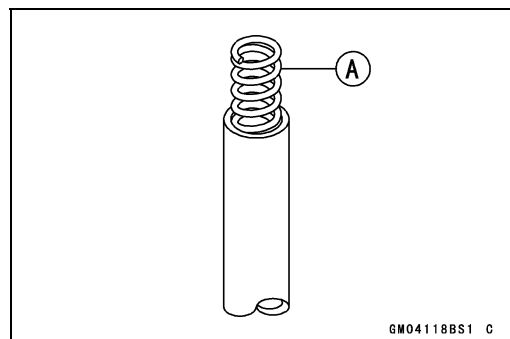
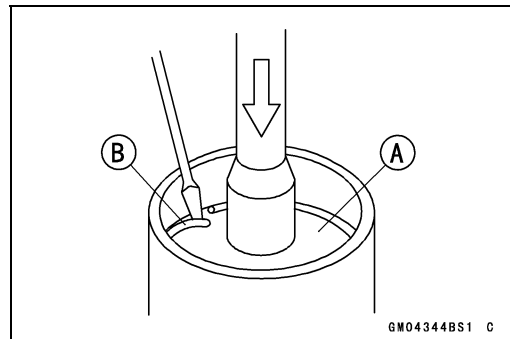

Front Fork

- Pour out the fork oil [A] with the fork upside down.
- Hold the outer tube vertically in a vise.
- Fill the front fork with the specified oil.

Suspension Oil - SS-8 (1 L): 44091-0007

Amount (Per Side):

When changing oil:

Approx. 365 mL (12.3 US oz.)

After disassembly and completely dry:

428 ±2.5 mL (14.5 ±0.084 US oz.)

- Wait for about five minutes so that any suspended air bubbles can surface.
- Measure the oil level, using the fork oil level gauge [A].

Special Tool - Fork Oil Level Gauge: 57001-1290

- Set the oil level gauge stopper [B] so that its lower side shows the oil level distance specified [C].
- Insert the gauge tube into the inner tube [D] and position the stopper across the top of the inner tube [E].
- Pull the handle slowly to draw out the excess oil until no more oil comes up the tube.
- ★ If not oil is drawn out, there is not enough oil in the fork. Pour in some more oil and measure again.

Oil Level (Fully compressed, without spring)

Standard: 150 ±2 mm (5.91 ±0.08 in.)

- Install the fork spring with the smaller end [A] facing downward [B].
Upward [C]

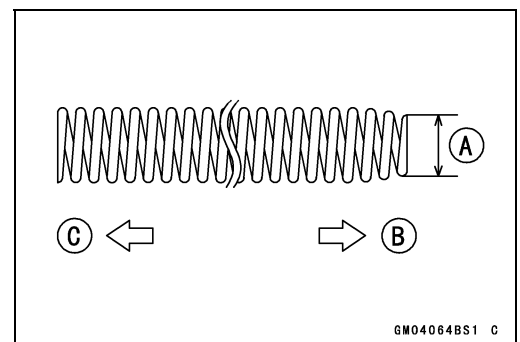
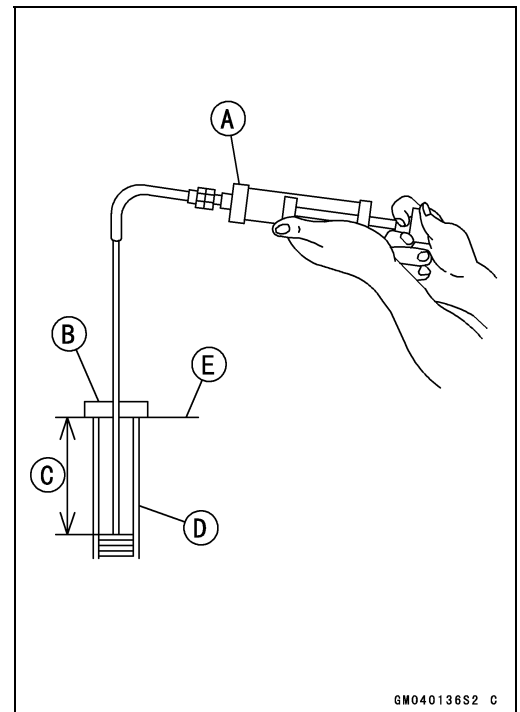
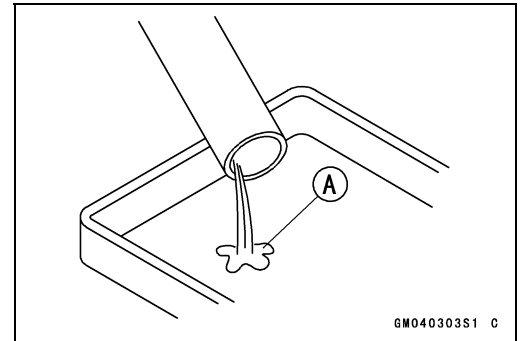

- Replace the O-ring on the top plug with a new one, and install it to the top plug.
- Push down the top plug to install the ring, and then fit the ring into the groove of the inner tube.
- Install the front fork (see Front Fork Installation).

Front Fork Disassembly

- Remove the front fork (see Front Fork Removal).
- Drain the fork oil (see Front Fork Oil Change).

13-10 SUSPENSION

Front Fork

- Hold the front fork horizontally in a vise [A].
- Stop the cylinder unit [B] from turning by using the special tools.
- Unscrew the Allen bolt [C], and take the gasket out of the bottom of the outer tube.

Special Tools - Fork Cylinder Holder Handle [D]: 57001-183
Fork Cylinder Holder Adapter [E]: 57001-1057

- Take the cylinder unit out of the inner tube.
- Remove the cylinder unit [A] and short spring [B] from the inner tube.

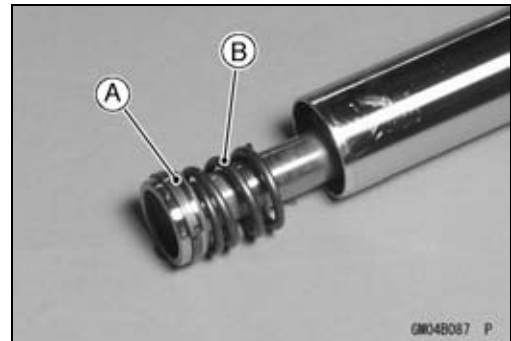
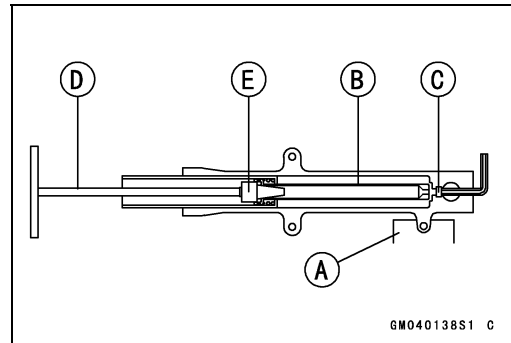

- Separate the inner tube from the outer tube as follows.
 - Slide up the dust seal [A].
 - Remove the retaining ring [B] from the outer tube.

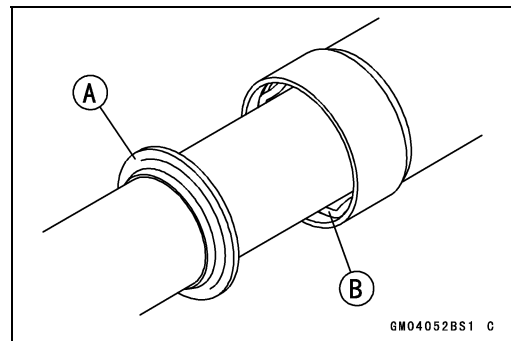

- Grasp the inner tube and stroke the outer tube up and down several times. The shock to the fork seal separates the inner tube from the outer tube.

★ If the tubes are tight, use a fork outer tube weight [A].

Special Tool - Fork Outer Tube Weight: 57001-1218

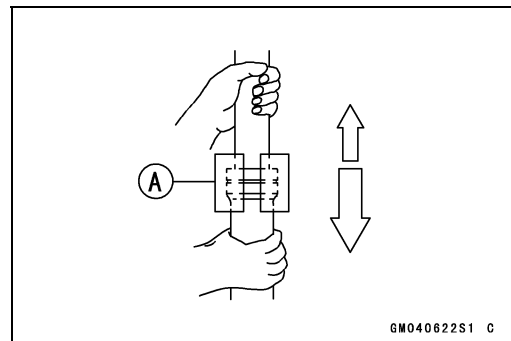

- Remove the inner guide bushing [A], outer guide bushing [B], washer [C] and oil seal [D] from the inner tube.
- Remove the cylinder base from the bottom of the outer tube.

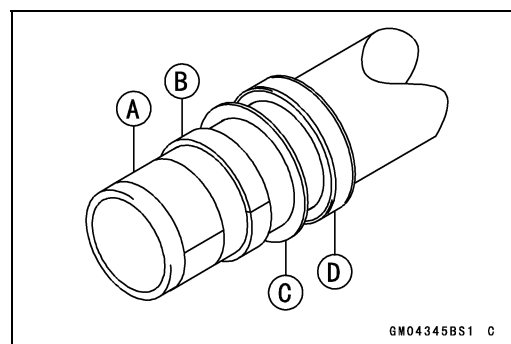

Front Fork

Front Fork Assembly

- Replace the following parts with new ones.
 - Dust Seal [A]
 - Retaining Ring [B]
 - Oil Seal [C]
 - Inner Guide Bushing [D]
 - Outer Guide Bushing [E]
 - Fork Bottom Allen Bolt Gasket [F]
- Install the following parts onto the inner tube.
 - Inner Guide Bushing
 - Outer Guide Bushing
 - Washer
 - Oil Seal
 - Retaining Ring
 - Dust Seal
- Insert the cylinder unit [A] into the inner tube [B].
- Install the cylinder base [C] on the cylinder unit so that the tapered end face the upward.
- Insert the inner tube, cylinder unit and cylinder base as a set into the outer tube [D].

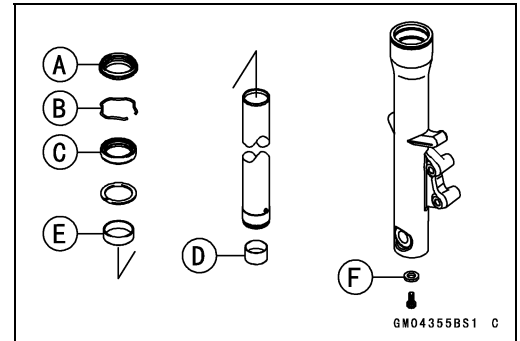

- Fit the new outer guide bushing [A] into the outer tube.

NOTE

○When assembling the new outer guide bushing, hold the used guide bushing [B] against the new bushing and tap the used guide bushing with the fork oil seal driver [C] until it stops.

Special Tool - Front Fork Oil Seal Driver: 57001-1219

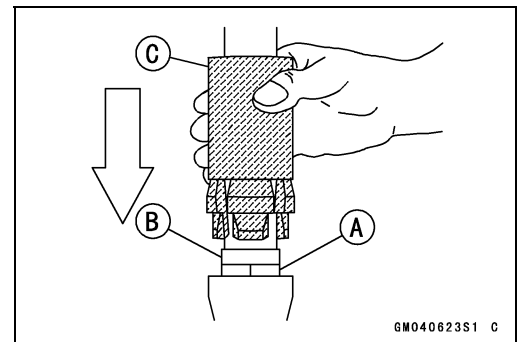
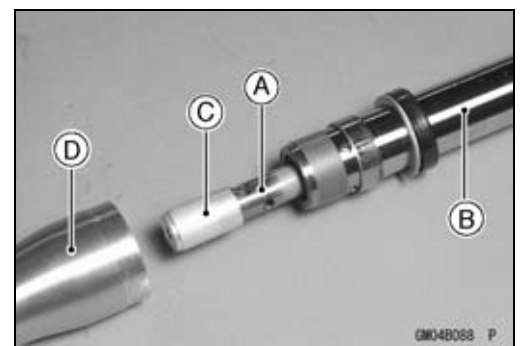

- Apply grease to the oil seal lips and install the washer [A] and the oil seal [B] into the outer tube.
- Face the flat side [C] of the seal upward.

Special Tool - Front Fork Oil Seal Driver [D]: 57001-1219

- Install:
 - Retaining Ring
 - Dust Seal

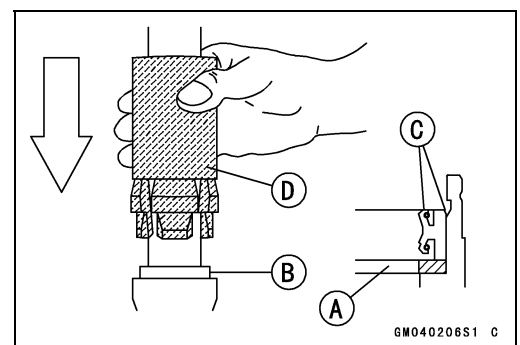

13-12 SUSPENSION

Front Fork

- Hold the front fork horizontally in a vise [A].
- Hold the cylinder unit [B] with the special tools and tighten the Allen bolt [C].

Special Tools - Fork Cylinder Holder Handle [D]: 57001-183
Fork Cylinder Holder Adapter [E]: 57001-1057

- Apply a non-permanent locking agent to the threads of the bottom Allen bolt, and tighten it.

Torque - Front Fork Bottom Allen Bolts: 20 N·m (2.0 kgf·m, 15 ft·lb)

- Pour in the specified type of oil (see Front Fork Oil Change).

Inner Tube Inspection

- Visually inspect the inner tube.
- ★ If there is any damage, replace the inner tube. Since damage to the inner tube damages the oil seal and dust seal, replace the oil seal and dust seal whenever the inner tube is replaced.

NOTICE

If the inner tube is badly bent or creased, replace it. Excessive bending, followed by subsequent straightening, can weaken the inner tube.

- Temporarily assemble the inner and outer tubes, and pump them back and forth manually to check for smooth operation.
- If you feel binding or catching, the inner and outer tubes must be replaced.

⚠ WARNING

A straightened inner or outer fork tube may fall in use, possibly causing an accident resulting in serious injury or death. Replace a badly bent or damaged inner or outer tube and inspect the other tube carefully before reusing it.

Dust Seal Inspection

- Inspect the dust seal [A] for any signs of deterioration or damage.
- ★ Replace it if necessary.

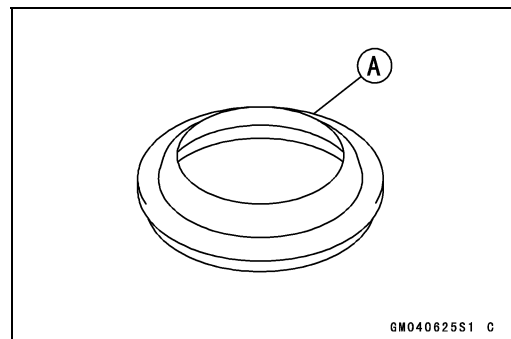
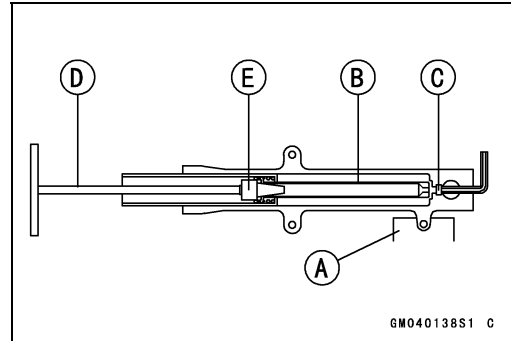

Front Fork

Fork Spring Inspection

- Measure the free length [A] of the fork spring [B].
- ★ If the measured length is shorter than the service limit, the spring must be replaced. If the free length of the replacement spring and that of the remaining spring vary greatly, the remaining spring should also be replaced in order to keep the fork legs balanced to ensure stability.

Fork Spring Free Length

Standard: 527.2 mm (20.76 in.)

Service Limit: 517 mm (20.4 in.)

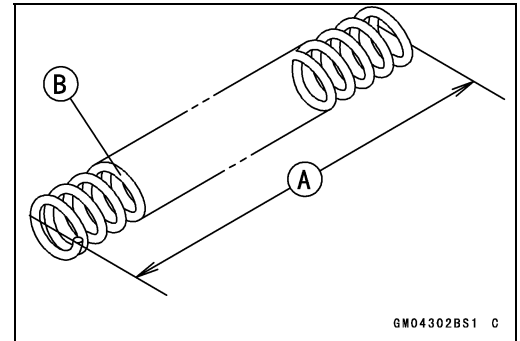

13-14 SUSPENSION

Rear Shock Absorber

Spring Preload Adjustment

- Remove the reserve tank (see Reserve Tank Removal in the Cooling System chapter).
- Hang the under part of the reserve tank to the holder [A] of the frame as shown in the figure.



- To adjust the spring force, turn the adjusting sleeve [A] on the shock absorber to the desired position with the hook wrench [B].

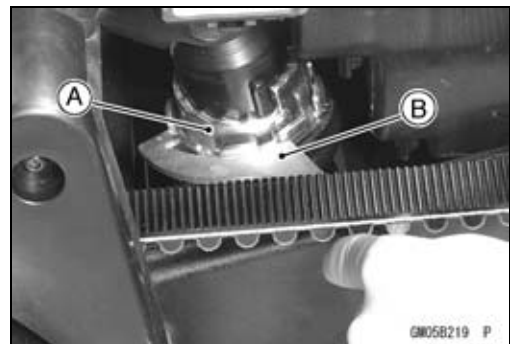

Owner's Tools- Hook Wrench, R31: 92110-0018

Hook Wrench, R32.5: 92110-1173

- The standard adjusting sleeve is 4th position from the weakest position.

Spring Preload Setting

Standard Position: 4th position

Adjustable Range: 1st ~ 7th position

- If the compression of the spring is not suited to the operating conditions, adjust it to an appropriate position by referring to the table below.

Spring Preload Adjustment

| Adjuster Position | Spring Force | Shock Absorber Hardness | Load | Road Conditions | Driving Speed |
|-------------------|--------------|-------------------------|-------|-----------------|---------------|
| 1st | Weak | Soft | Light | Good | Low |
| ↑ | ↑ | ↑ | ↑ | ↑ | ↑ |
| ↓ | ↓ | ↓ | ↓ | ↓ | ↓ |
| 7th | Strong | Hard | Heavy | Bad | Highway |

Rear Shock Absorber Removal

- Remove the mufflers (see Muffler Removal in the Engine Top End chapter).
- Raise the rear wheel off the ground with jack.

Special Tool - Jack: 57001-1238

- Squeeze the brake lever slowly and hold it with a band [A].



⚠ WARNING

Be sure to hold the front brake when removing the shock absorber, or the motorcycle may fall over. It could cause an accident and injury.

Rear Shock Absorber

- Remove:
 - Lower Shock Absorber Bolt [A]
 - Lower Tie-Rod Bolt [B]
 - Upper Shock Absorber Bolt [C]
 - Rear Shock Absorber

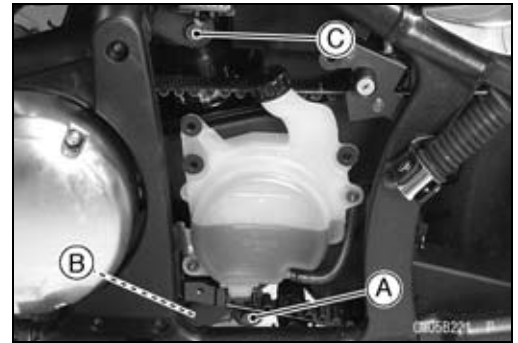

Rear Shock Absorber Installation

- Pack the rocker arm needle bearings with grease.
- Install the rear shock absorber so that the CAUTION label [A] faces left side.
- Replace the rear shock absorber nuts and the lower tie-rod nut with new ones.
- Tighten:

Torque - Rear Shock Absorber Nuts: 59 N·m (6.0 kgf·m, 44 ft·lb)

Tie-Rod Nut (Lower): 59 N·m (6.0 kgf·m, 44 ft·lb)

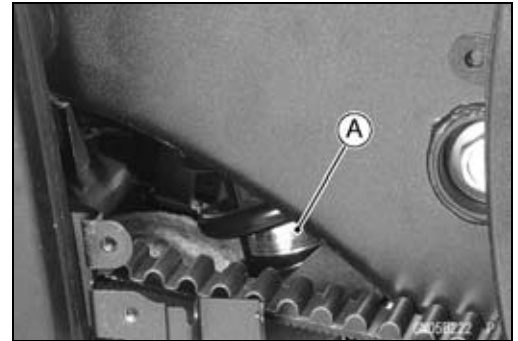

Rear Shock Absorber Inspection

- Remove the rear shock absorber (see Rear Shock Absorber Removal).
- Visually inspect the following items.
 - Oil Leakage (see Rear Shock Absorber Oil Leak Inspection in the Periodic Maintenance chapter)
 - Crack or Dent
- ★ If there is any damage to the rear shock absorber, replace it.
- Visually inspect the rubber bushing [A].
- ★ If they show any signs of damage, replace it.

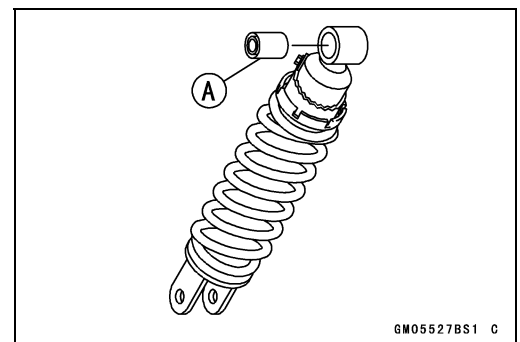

Rear Shock Absorber Scrapping

⚠ WARNING

Since the rear shock absorber contains nitrogen gas, do not incinerate the rear shock absorber without first releasing the gas or it may explode. Before a rear shock absorber is scrapped, drill a hole at the point [A] shown to release the nitrogen gas completely. Wear safety glasses when drilling the hole, as the gas may blow out bits of drilled metal when the hole opens.

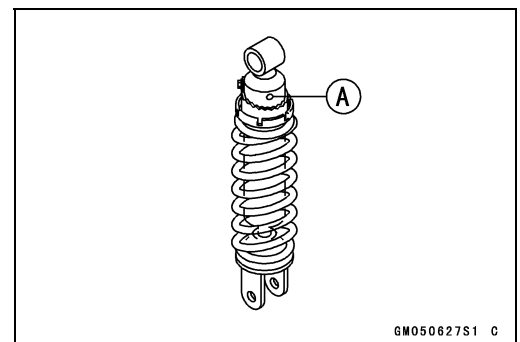

13-16 SUSPENSION

Swingarm

Swingarm Removal

- Remove:
 - Rear Wheel (see Rear Wheel Removal in the Wheels/Tires chapter)
 - Rear Caliper (see Rear Caliper Removal in the Brakes chapter)
 - Rear Shock Absorber (see Rear Shock Absorber Removal)
 - Bolts [A]
 - Rear Wheel Mud Guard [B]
- Remove:
 - Drive Belt Cover [A]
 - Rear Pulley Cover [B]
- Remove the lower tie-rod bolt, and clear the tie-rod [A] from the rocker arm [B].
- Remove:
 - Reserve Tank (with the hose installed) (see Reserve Tank Removal in the Cooling System chapter)
 - Upper Tie-Rod Bolt [A] (Loosen)
 - Swingarm Pivot Shaft Nut
- Pull off the pivot shaft [B] and remove the swingarm together with the tie-rod.

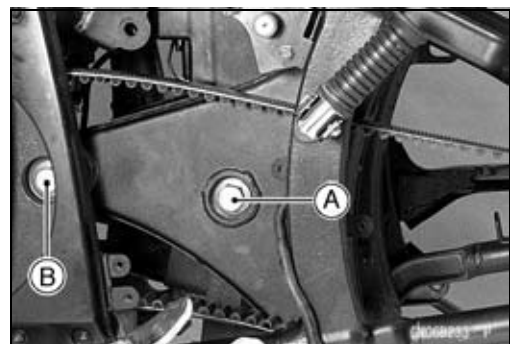
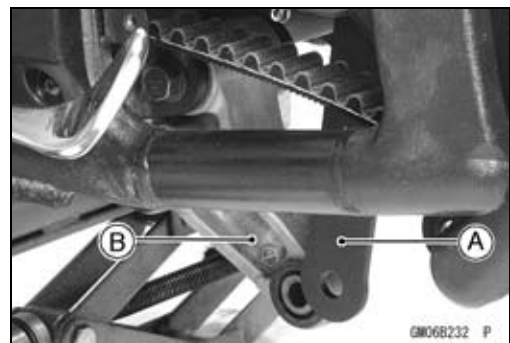
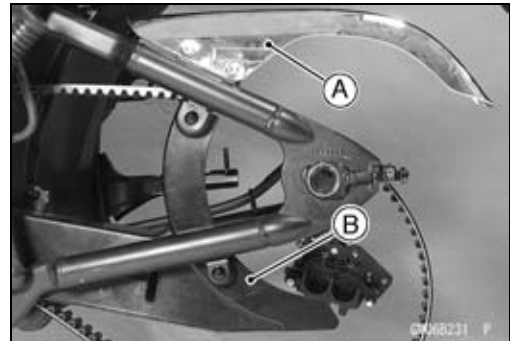
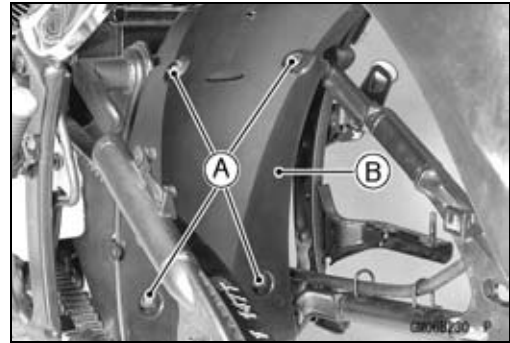

Swingarm

Swingarm Installation

- Apply grease to the needle bearings and grease seals.
- Install the collar [A].
- Replace the rear shock absorber nuts and the tie-rod nuts with new ones.
- Install the tie-rod to the swingarm.
- Install the swingarm and insert the swingarm pivot shaft from the left side.
- Tighten:

Torque - Swingarm Pivot Shaft Nut: 98 N·m (10 kgf·m, 72 ft·lb)

Tie-Rod Nut (Upper): 108 N·m (11.0 kgf·m, 80 ft·lb)

Tie-Rod Nut (Lower): 59 N·m (6.0 kgf·m, 44 ft·lb)

Rear Shock Absorber Nuts: 59 N·m (6.0 kgf·m, 44 ft·lb)

- Install the removed parts (see appropriate chapters).

Swingarm Bearing Removal

- Remove the swingarm (see Swingarm Removal).

Left Side

- Remove:
 - Collar
 - Grease Seal [A]

- Remove the circlip [A].

Special Tool - Inside Circlip Pliers [B]: 57001-143

- Remove the ball bearing [A] and needle bearing with the available bearing remover [B].
- Remove the sleeve.

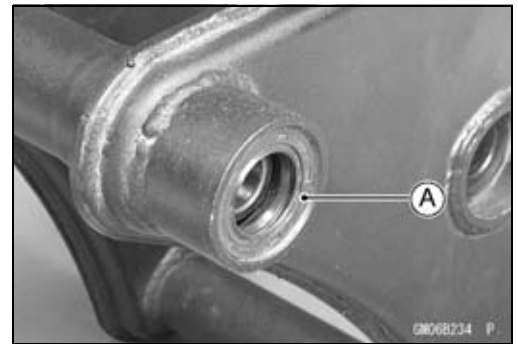
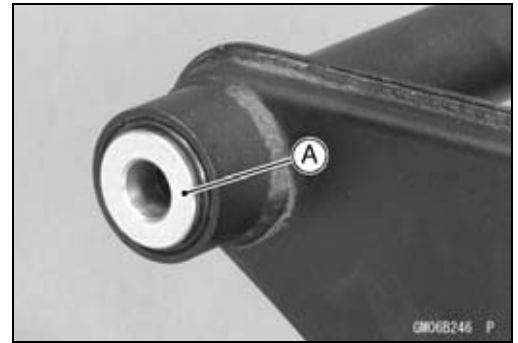

13-18 SUSPENSION

Swingarm

Right Side

- Remove the grease seal.
- Remove the needle bearing [A] with the available bearing remover.

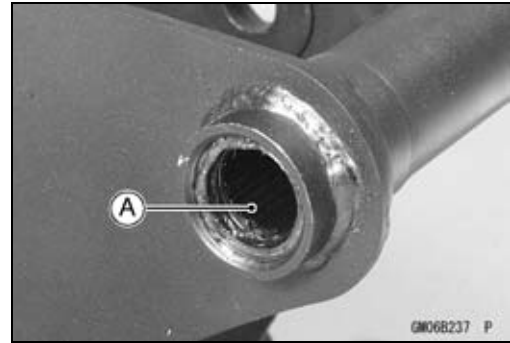

Swingarm Bearing Installation

- Replace the grease seals, ball and needle bearings with new ones.
- Apply grease to the grease seals, ball and needle bearings.
- Be sure to install the needle bearings so that the manufacturer's marks are faced out. This prevents bearing damage.
- Position the following bearings as shown in the figure, using a suitable bearing driver in the bearing driver set.

Special Tool - Bearing Driver Set: 57001-1129

Left Side

- Swingarm [A]
- Needle Bearing [B]
- 28 ±2 mm (1.1 ±0.08 in.) [C]
- Ball Bearing (until bottom end) [D]
- Circlip [E]
- Grease Seal [F]
- Collar [G]

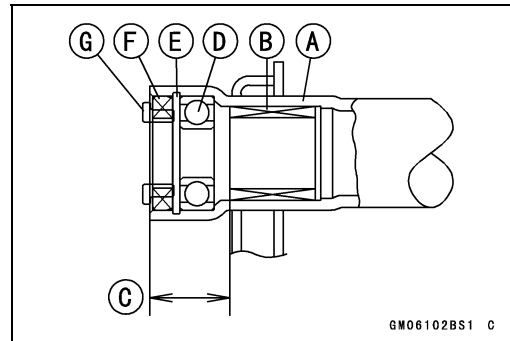

Right Side

- Swingarm [A]
- Needle Bearing [B]
- 8 ±2 mm (0.3 ±0.08 in.) [C]
- Grease Seal [D]

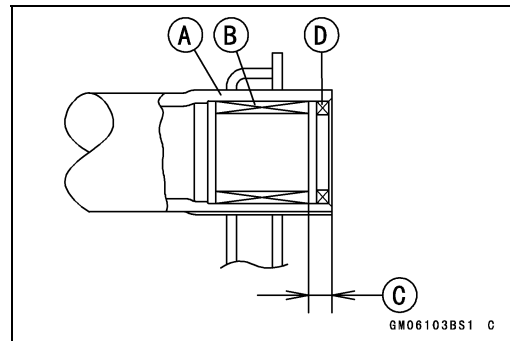

Swingarm

Swingarm Bearing, Sleeve Inspection

NOTICE

Do not remove the bearings for inspection. Removal may damage them.

- Inspect the sleeve [A], needle bearings [B] and ball bearing [C] installed in the swingarm.
- The rollers and balls in the bearing normally wear very little, and wear is difficult to measure. Instead of measuring, visually inspect the bearings for abrasion, discoloration, or other damage.
- ★ If the sleeve, needle and ball bearings show any signs of abnormal wear, discoloration, or damage, replace them as a set.

Grease Seal and Needle Bearing Lubrication

- Refer to the Swingarm Pivot Lubrication in the Periodic Maintenance chapter.

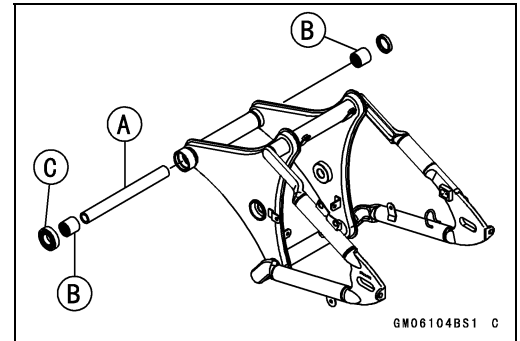

13-20 SUSPENSION

Tie-Rod, Rocker Arm

Tie-Rod Removal

- Refer to the Swingarm Removal.

Tie-Rod Installation

- Refer to the Swingarm Installation.

Rocker Arm Removal

- Remove the mufflers (see Muffler Removal in the Engine Top End chapter).
- Squeeze the brake lever slowly and hold it with a band.
- Raise the rear wheel off the ground, using the suitable jack in front of the rocker arm.
- Loosen the swingarm pivot shaft nut.
- Remove:
 - Rear Shock Absorber (see Rear Shock Absorber Removal)
 - Lower Tie-Rod Nut and Bolt
 - Rocker Arm Pivot Shaft Nut and Shaft [A]
 - Rocker Arm [B]

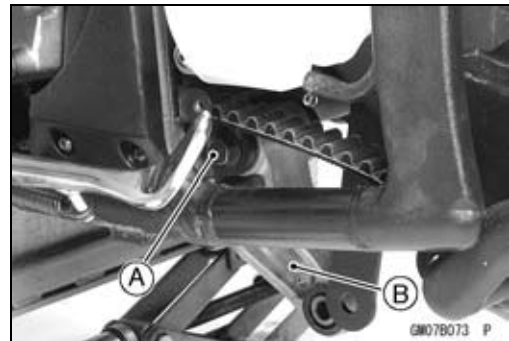

Rocker Arm Installation

- Apply grease to the inside of the needle bearings and grease seals.
- Replace the rocker arm pivot shaft nut and the lower tie-rod nut with new ones.
- Tighten:
 - Torque - Rocker Arm Pivot Shaft Nut: 59 N·m (6.0 kgf·m, 44 ft·lb)**
 - Tie-Rod Nut (Lower): 59 N·m (6.0 kgf·m, 44 ft·lb)**
 - Swingarm Pivot Shaft Nut: 98 N·m (10 kgf·m, 72 ft·lb)**
- Install the removed parts (see appropriate chapters).

Tie-Rod, Rocker Arm

Tie-Rod and Rocker Arm Bearing Removal

- Remove:
 - Tie-Rod (see Swingarm Removal)
 - Rocker Arm [A] (see Rocker Arm Removal)
 - Sleeves [B]
 - Grease Seals [C]
- Remove the needle bearings [D], using the available bearing remover.
 - VN900C7 ~ C9 Models [E]

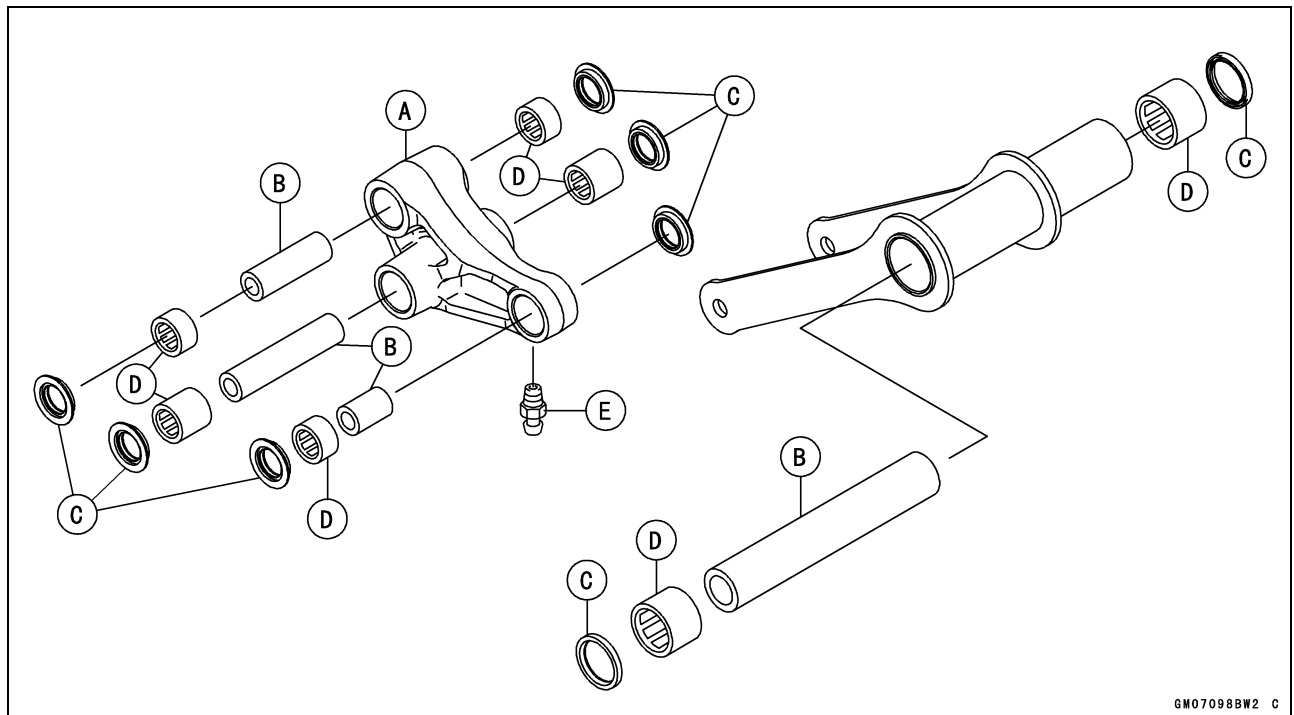

Tie-Rod and Rocker Arm Bearing Installation

- Replace the needle bearings and grease seals with new ones.
- Apply grease to the needle bearings and grease seals.
- Install the needle bearings and grease seals as shown in the figure.

Special Tool - Bearing Driver Set: 57001-1129

13-22 SUSPENSION

Tie-Rod, Rocker Arm

NOTE

○ Install the needle bearings so that the marked side faces out.

Needle Bearings [A]

Grease Seals [B]

Front [C]

Left Side [D]

Right Side [E]

Rocker Arm [F]

Tie-Rod [G]

6 ± 1 mm (0.24 ± 0.04 in.) [H]

11.5 ± 1 mm (0.453 ± 0.04 in.) [I]

5.5 ± 1 mm (0.22 ± 0.04 in.) [J]

6.5 ± 2 mm (0.26 ± 0.08 in.) [K]

52 ± 2 mm (2.0 ± 0.08 in.) [L]

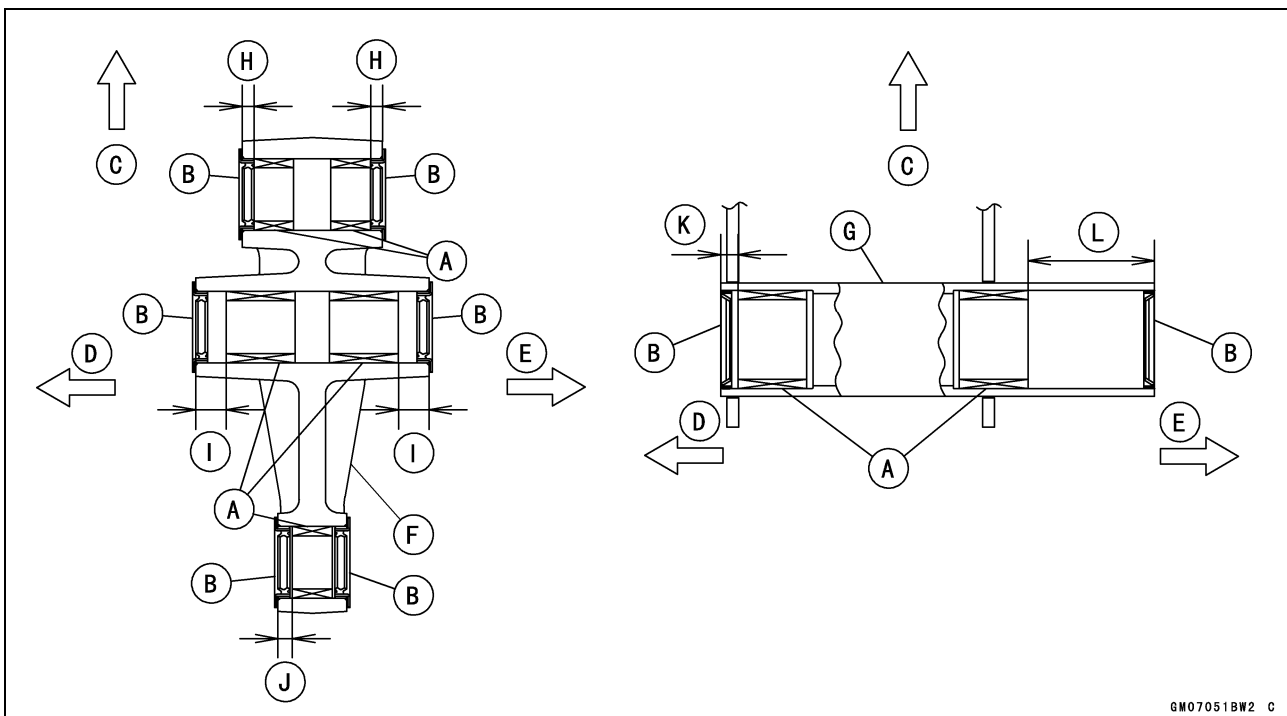

Steering

Table of Contents

| | |
|--------------------------------------|-------|
| Exploded View..... | 14-2 |
| Special Tools | 14-4 |
| Steering | 14-5 |
| Steering Inspection | 14-5 |
| Steering Adjustment..... | 14-5 |
| Steering Stem..... | 14-6 |
| Stem, Stem Bearing Removal..... | 14-6 |
| Stem, Stem Bearing Installation..... | 14-7 |
| Stem Bearing Lubrication..... | 14-9 |
| Steering Stem Warp Inspection | 14-9 |
| Handlebar | 14-10 |
| Handlebar Removal | 14-10 |
| Handlebar Installation | 14-10 |

14-2 STEERING

Exploded View

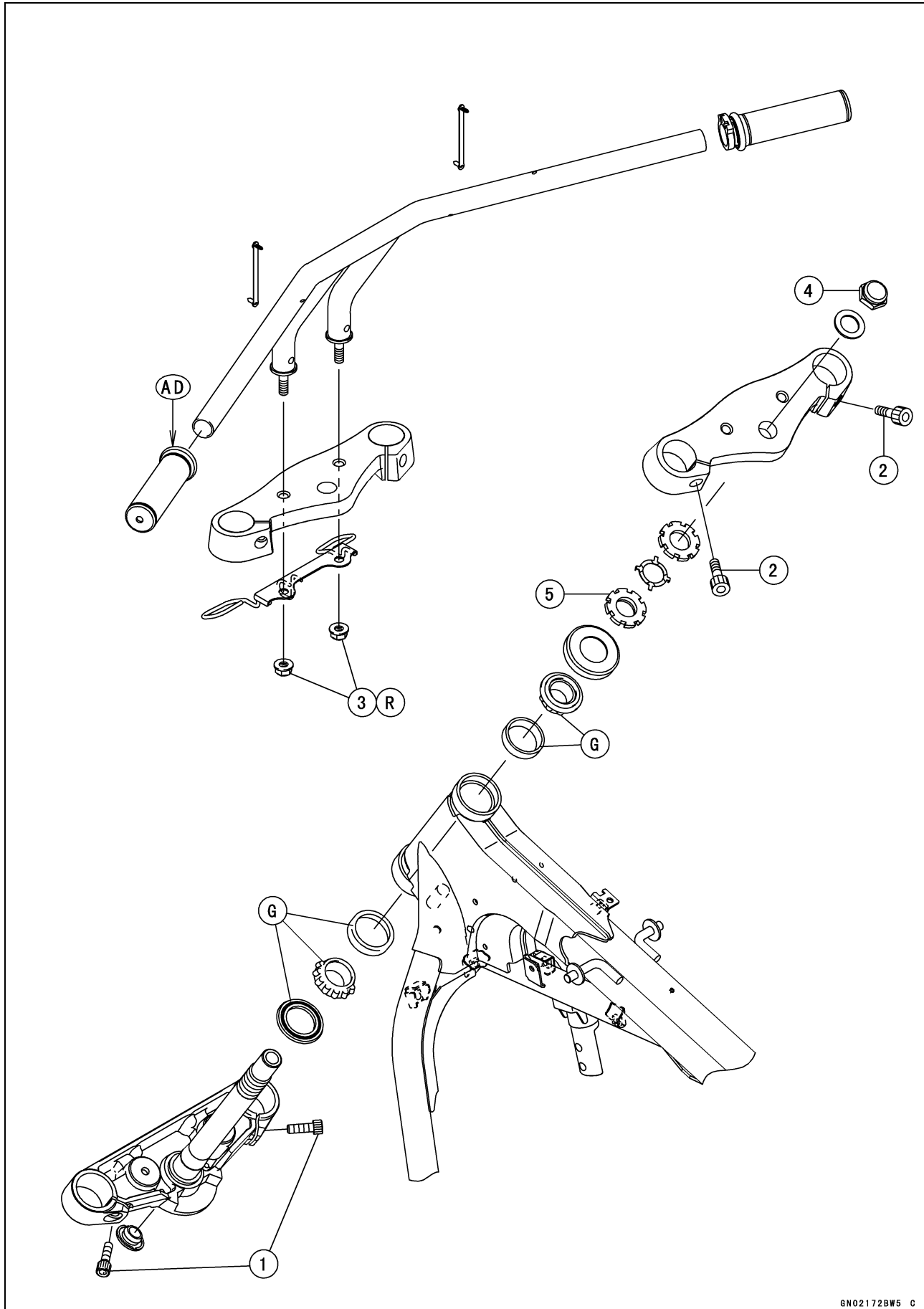

GN02172BW5 C

Exploded View

| No. | Fastener | Torque | | | Remarks |
|-----|--------------------------------|--------|-------|----------|---------|
| | | N·m | kgf·m | ft·lb | |
| 1 | Front Fork Clamp Bolts (Lower) | 34 | 3.5 | 25 | |
| 2 | Front Fork Clamp Bolts (Upper) | 20 | 2.0 | 15 | |
| 3 | Handlebar Mounting Nuts | 34 | 3.5 | 25 | R |
| 4 | Steering Stem Head Nut | 49 | 5.0 | 36 | |
| 5 | Steering Stem Nut | 4.9 | 0.50 | 43 in·lb | |

AD: Apply adhesive.

G: Apply grease.

R: Replacement Parts

14-4 STEERING

Special Tools

Bearing Puller:
57001-135

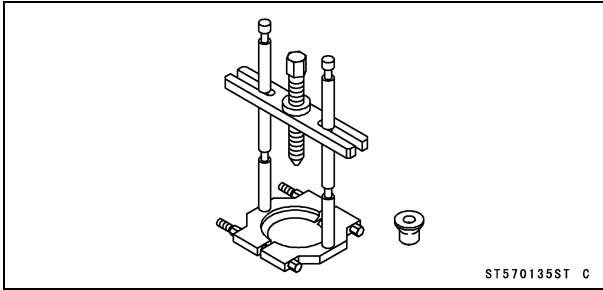

Steering Stem Bearing Driver:
57001-137

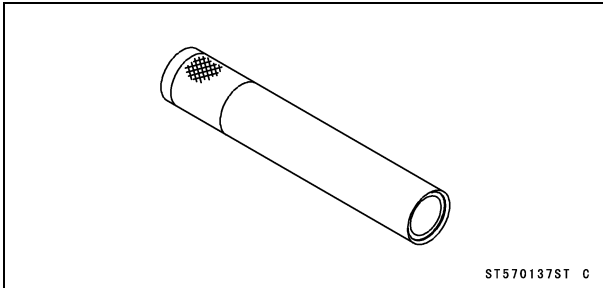

Steering Stem Bearing Driver Adapter, $\phi 34.5$:
57001-1074

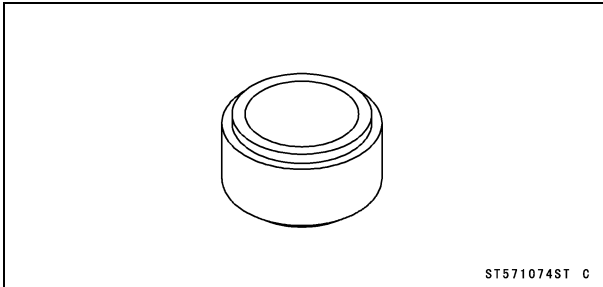

Head Pipe Outer Race Press Shaft:
57001-1075

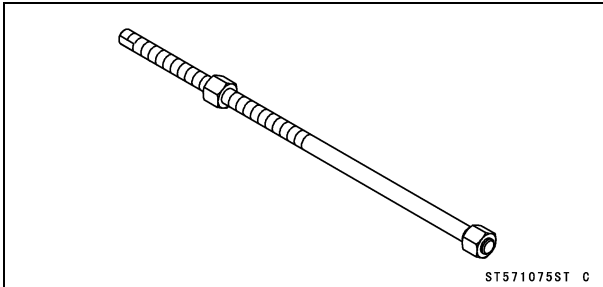

Head Pipe Outer Race Driver, $\phi 51.5$:
57001-1076

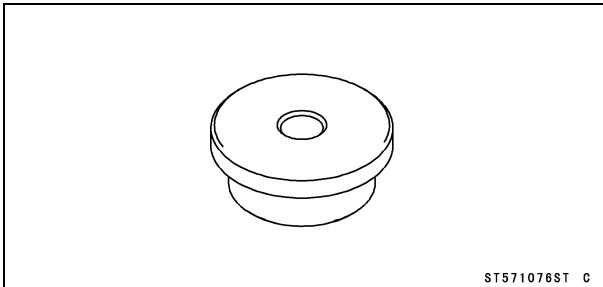

Steering Stem Nut Wrench:
57001-1100

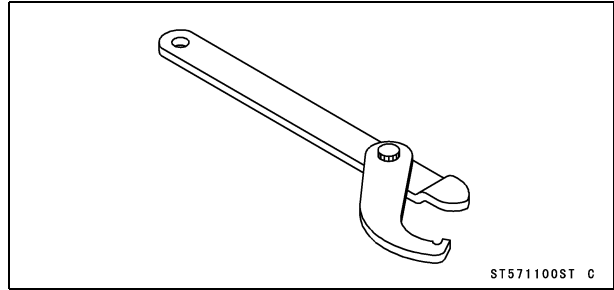

Head Pipe Outer Race Driver, $\phi 46.5$:
57001-1106

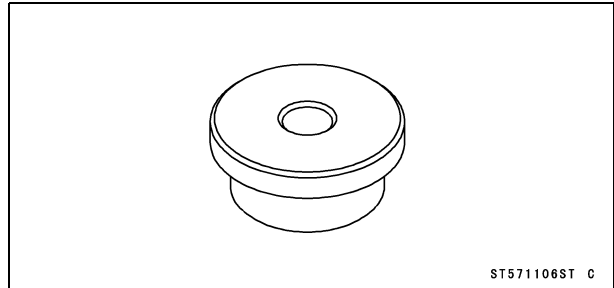

Head Pipe Outer Race Remover, ID > 37 mm:
57001-1107

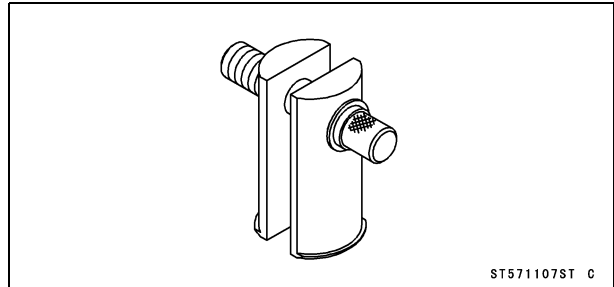

Bearing Puller:
57001-1675

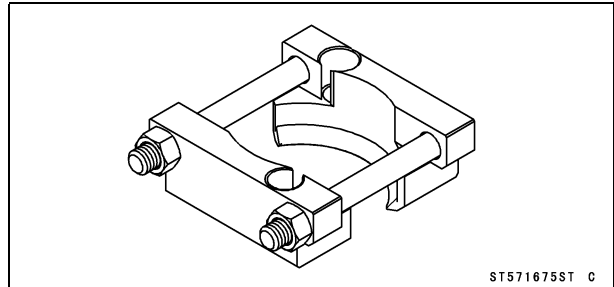

Steering

Steering Inspection

- Refer to the Steering Play Inspection in the Periodic Maintenance chapter.

Steering Adjustment

- Refer to the Steering Play Adjustment in the Periodic Maintenance chapter.

14-6 STEERING

Steering Stem

Stem, Stem Bearing Removal

- Remove:
 - Headlight Body (see Headlight Body Removal in the Electrical System chapter)
 - Front Turn Signal Lights (see Front Fork Removal in the Suspension chapter)
 - Headlight Body Bracket Nuts [A] and Bracket [B]
 - Bolt [C] and Bracket [D]

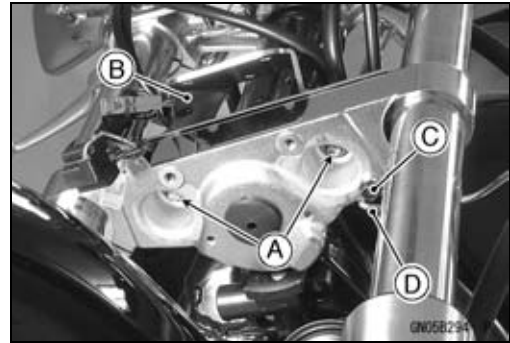

- Remove:
 - Front Wheel (see Front Wheel Removal in the Wheels/Tires chapter)
 - Front Forks [A] (see Front Fork Removal in the Suspension chapter)
 - Handlebar [B] (see Handlebar Removal)
 - Steering Stem Head Nut [C] and Washer
 - Steering Stem Head [D]

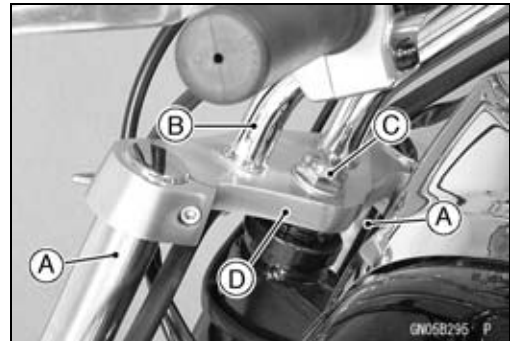

- Bend the claws [A] of the claw washer straighten.
- Remove:
 - Steering Stem Locknut [B]
 - Claw Washer

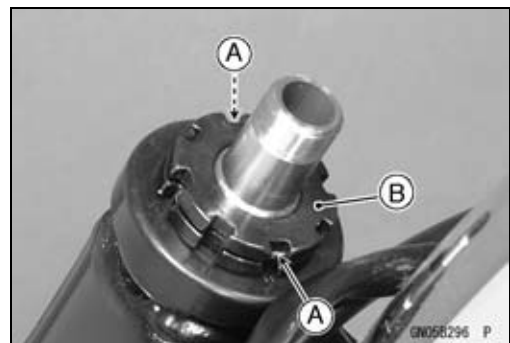

- Remove the steering stem nut [A].
 - Special Tool - Steering Stem Nut Wrench [B]: 57001-1100**
- Remove the stem cap [C] and bearing.
- Pull out the steering stem [D] from the bottom.
- Remove the plug at steering stem bottom.

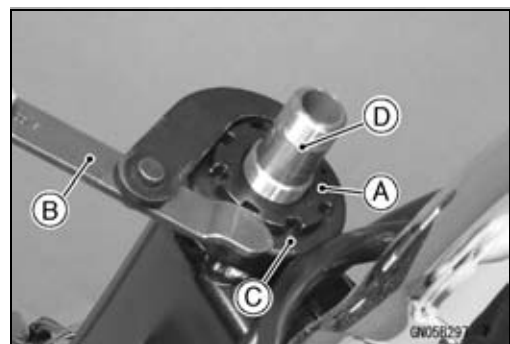

- Drive out the bearing outer races from the head pipe.
 - Special Tool - Head Pipe Outer Race Remover, ID > 37 mm [A]: 57001-1107**

NOTE

○ If either steering stem bearing is damaged, it is recommended that both the upper and lower bearings (including outer races) be replaced with new ones.

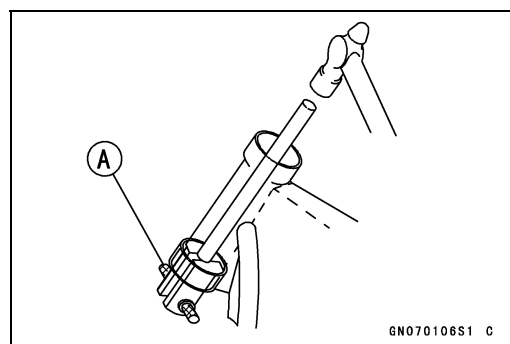

Steering Stem

- Remove the lower inner race [A] which is pressed onto the steering stem with special tools.
Oil Seal [B]

Special Tools - Bearing Puller: 57001-135
Bearing Puller: 57001-1675

- Insert the each half-split base [A] under the bottom of the bearing and connect the both bases by tightening the M8 bolts [B].
- Assemble the parts of the bearing puller [C], adapter [D] and arm [E] as shown in the figure.
- Turn the center bolt [F] by a wrench and pull the bearing off.

NOTE

- Tighten evenly two bases by the two M8 bolts.

Stem, Stem Bearing Installation

- Replace the bearing outer races with new ones.
- Apply grease to the outer races, and drive them into the head pipe at the same time.

Special Tools - Head Pipe Outer Race Press Shaft [A]:
57001-1075
Head Pipe Outer Race Driver, $\phi 51.5$ [B]:
57001-1076
Head Pipe Outer Race Driver, $\phi 46.5$ [C]:
57001-1106

- Replace the bearing inner races and oil seal with new ones.
- Apply grease to the lower inner race [A] and oil seal, and drive them onto the stem base.

Special Tools - Steering Stem Bearing Driver [B]: 57001-137
Steering Stem Bearing Driver Adapter, $\phi 34.5$ [C]: 57001-1074

- Apply grease to the bearing.
- Install:
Steering Stem [A]
Bearing [B]
Stem Cap [C]
Steering Stem Nut [D]
Plug [E]

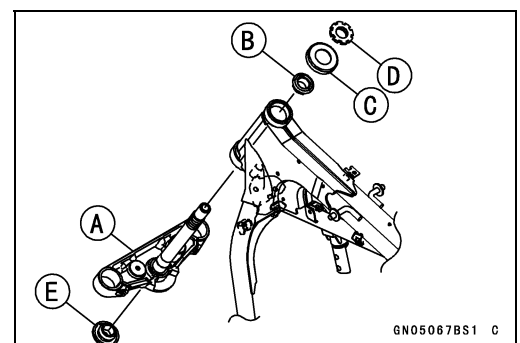
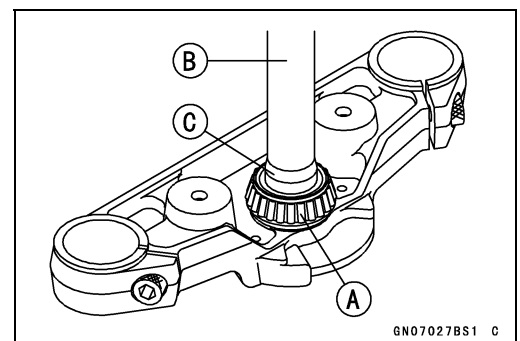
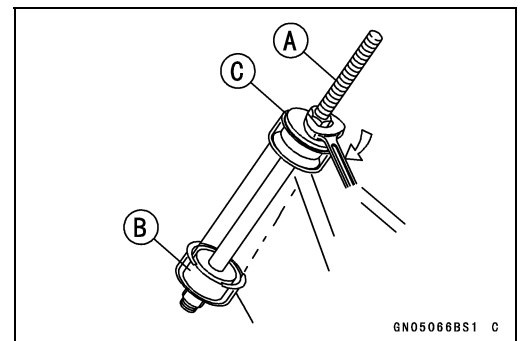
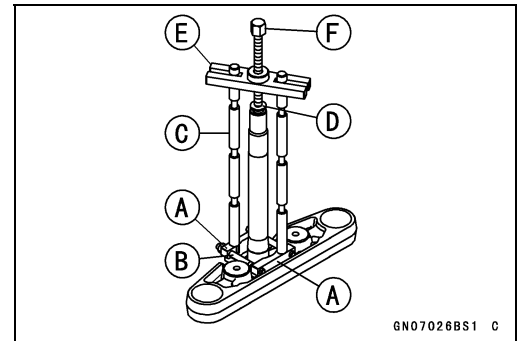
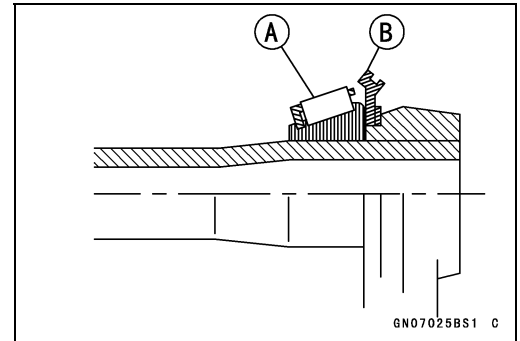

14-8 STEERING

Steering Stem

- Settle the bearings in place as follows.
- Tighten the steering stem nut to **55 N·m (5.6 kgf·m, 40 ft·lb)** of torque (To tighten the steering stem nut to the specified torque, hook the wrench on the stem nut, and pull the wrench at the hole by **305 N (31.1 kgf, 68.6 lb)** force in the direction shown.)

Special Tool - Steering Stem Nut Wrench [A]: 57001-1100

- Loosen the steering stem nut.
- Retighten the steering stem nut to the specified torque.

Torque - Steering Stem Nut: 4.9 N·m (0.50 kgf·m, 43 in·lb)

- For the torque of 4.9 N·m (0.50 kgf·m, 43 in·lb), pull the wrench at the hole by 27 N (2.8 kgf, 6.1 lb) force.
- Check that there is no play and the steering stem turns smoothly without rattles. If not, the steering stem bearings may be damaged.

- Replace the claw washer [A] with a new one.
- Install the claw washer so that its bent side [B] faces upward, and engage the bent claws with the grooves of stem locknut [C].
- Hand tighten the stem locknut until it touches the claw washer.
- Tighten the stem locknut clockwise until the claws are aligned with the grooves (ranging from 2nd to 4th) of stem nut [D], and bend the 2 claws downward [E].
- Install the stem head.
- Install the washer [F], and tighten the stem head nut [G] with specified torque.
- Install the front forks (see Front Fork Installation in the Suspension chapter).

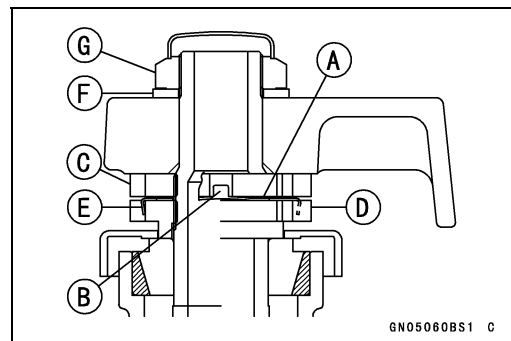
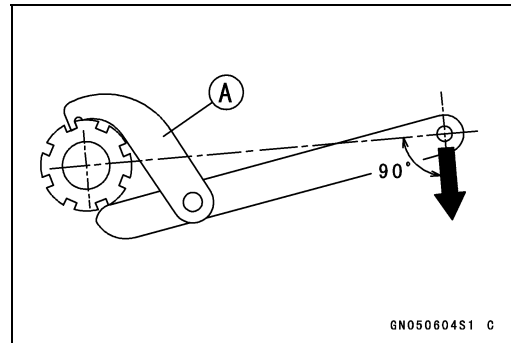

Steering Stem

NOTE

○ Tighten the upper fork clamp bolts first, next the stem head nut, last the lower fork clamp bolts.

Torque - Front Fork Clamp Bolts (Upper): 20 N·m (2.0 kgf·m, 15 ft·lb)

Steering Stem Head Nut: 49 N·m (5.0 kgf·m, 36 ft·lb)

Front Fork Clamp Bolts (Lower): 34 N·m (3.5 kgf·m, 25 ft·lb)

⚠ WARNING

If the handlebar does not turn to the steering stop it may cause an accident resulting in injury or death. Be sure the cables, harnesses and hoses are routed properly and do not interfere with handlebar movement (see Cable, Wire, and Hose Routing section in the Appendix chapter).

- Install the removed parts (see appropriate chapters).
- Check and adjust the following items after installation.
 - Steering (see Steering Play Inspection in the Periodic Maintenance chapter)
 - Throttle Cables (see Throttle Control System Inspection in the Periodic Maintenance chapter)
 - Headlight Aim (see Headlight Aiming Inspection in the Periodic Maintenance chapter)

Stem Bearing Lubrication

- Refer to the Steering Stem Bearing Lubrication in the Periodic Maintenance chapter.

Steering Stem Warp Inspection

- Whenever the steering stem is removed, or if the steering cannot be adjusted for smooth action, check the steering stem for straightness.
- ★ If the steering stem [A] is bent, replace the steering stem.

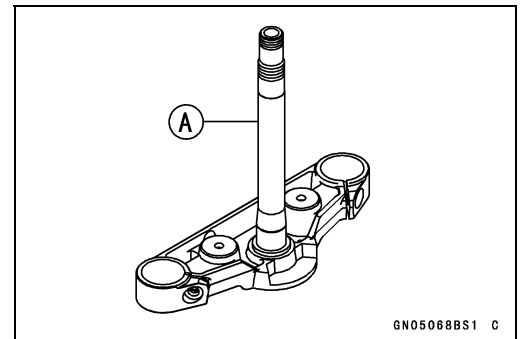

14-10 STEERING

Handlebar

Handlebar Removal

- Remove:
 - Clamp [A]
 - Clutch Lever Assembly [B]
 - Left Switch Housing [C]

- Remove:
 - Clamp [A]
 - Front Master Cylinder [B] (see Front Master Cylinder Removal in the Brakes chapter)
 - Right Switch Housing [C]
 - Throttle Grip [D]

- Remove the handlebar mounting nuts [A] and then pull out the handlebar.

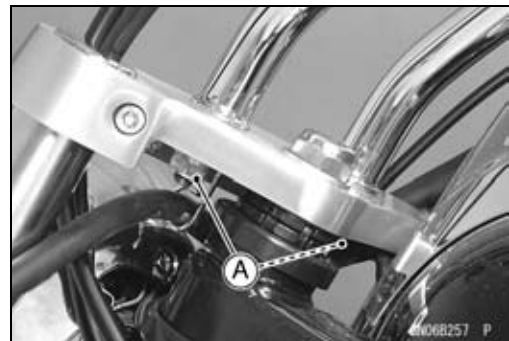
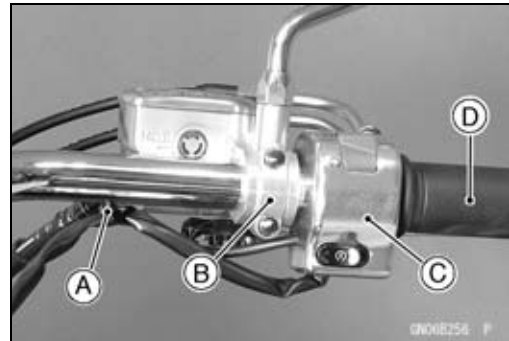
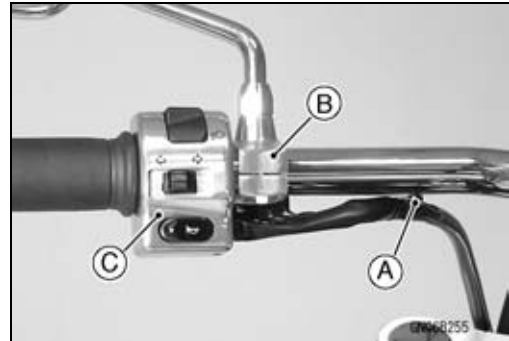

Handlebar Installation

- Set the handlebar [A] to the steering stem head [B].
- Replace the handlebar mounting nuts with new ones.
- Tighten:
 - Torque - Handlebar Mounting Nuts: 34 N·m (3.5 kgf·m, 25 ft·lb)**

- Install the throttle grip and throttle cable tips.
- The front half of the right switch housing has a small projection [A].
- Fit the projection into the small hole [B] of the handlebar, and install the switch housing.
- Install the front master cylinder (see Front Master Cylinder Installation in the Brakes chapter).

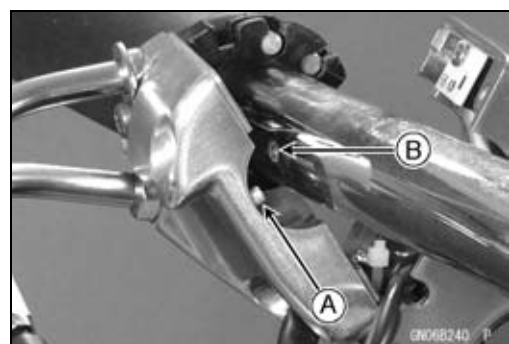
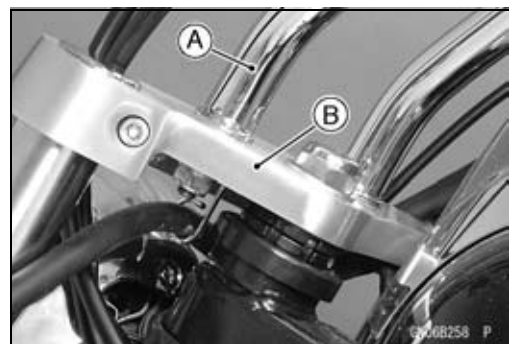

Handlebar

- Set the left switch housing [A] to match its mating surface [B] to the punched mark [C] of the handlebar.
- Install the switch housing.
- Install the clutch lever (see Clutch Lever Installation in the Clutch chapter).

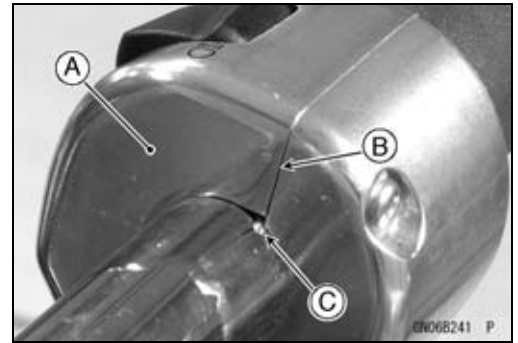

Frame

Table of Contents

| | |
|--|-------|
| Exploded View..... | 15-2 |
| Special Tool..... | 15-6 |
| Seat..... | 15-7 |
| Seat Removal..... | 15-7 |
| Seat Installation..... | 15-7 |
| Side Covers..... | 15-8 |
| Left Side Cover Removal..... | 15-8 |
| Left Side Cover Installation..... | 15-8 |
| Right Side Cover Removal..... | 15-8 |
| Right Side Cover Installation..... | 15-9 |
| Fenders..... | 15-10 |
| Front Fender Removal..... | 15-10 |
| Front Fender Installation..... | 15-10 |
| Flap and Rear Fender Removal..... | 15-10 |
| Flap and Rear Fender Installation..... | 15-11 |
| Battery Case..... | 15-12 |
| Battery Case Removal..... | 15-12 |
| Tool Box..... | 15-13 |
| Tool Box Removal..... | 15-13 |
| Footpeg..... | 15-14 |
| Footpeg Removal/Installation..... | 15-14 |
| Sidestand..... | 15-15 |
| Sidestand Removal..... | 15-15 |
| Sidestand Installation..... | 15-15 |
| Rear View Mirrors..... | 15-16 |
| Rear View Mirror Removal (Other than EUR, BR, PH and SEA-B1 Models [VN900C8 Late Models, VN900C9 ~ CD Models])..... | 15-16 |
| Rear View Mirror Removal (EUR, BR, PH and SEA-B1 Models [VN900C8 Late Models, VN900C9 ~ CD Models])..... | 15-16 |
| Rear View Mirror Removal (VN900CE ~ Model)..... | 15-16 |
| Rear View Mirror Installation (Other than EUR, BR, PH and SEA-B1 Models [VN900C8 Late Models, VN900C9 ~ CD Models])..... | 15-16 |
| Rear View Mirror Installation (EUR, BR, PH and SEA-B1 Models [VN900C8 Late Models, VN900C9 ~ CD Models])..... | 15-17 |
| Rear View Mirror Installation (VN900CE ~ Model)..... | 15-17 |
| Downtube..... | 15-18 |
| Downtube Removal..... | 15-18 |
| Downtube Installation..... | 15-19 |
| Frame..... | 15-20 |
| Frame Inspection..... | 15-20 |

15-2 FRAME

Exploded View

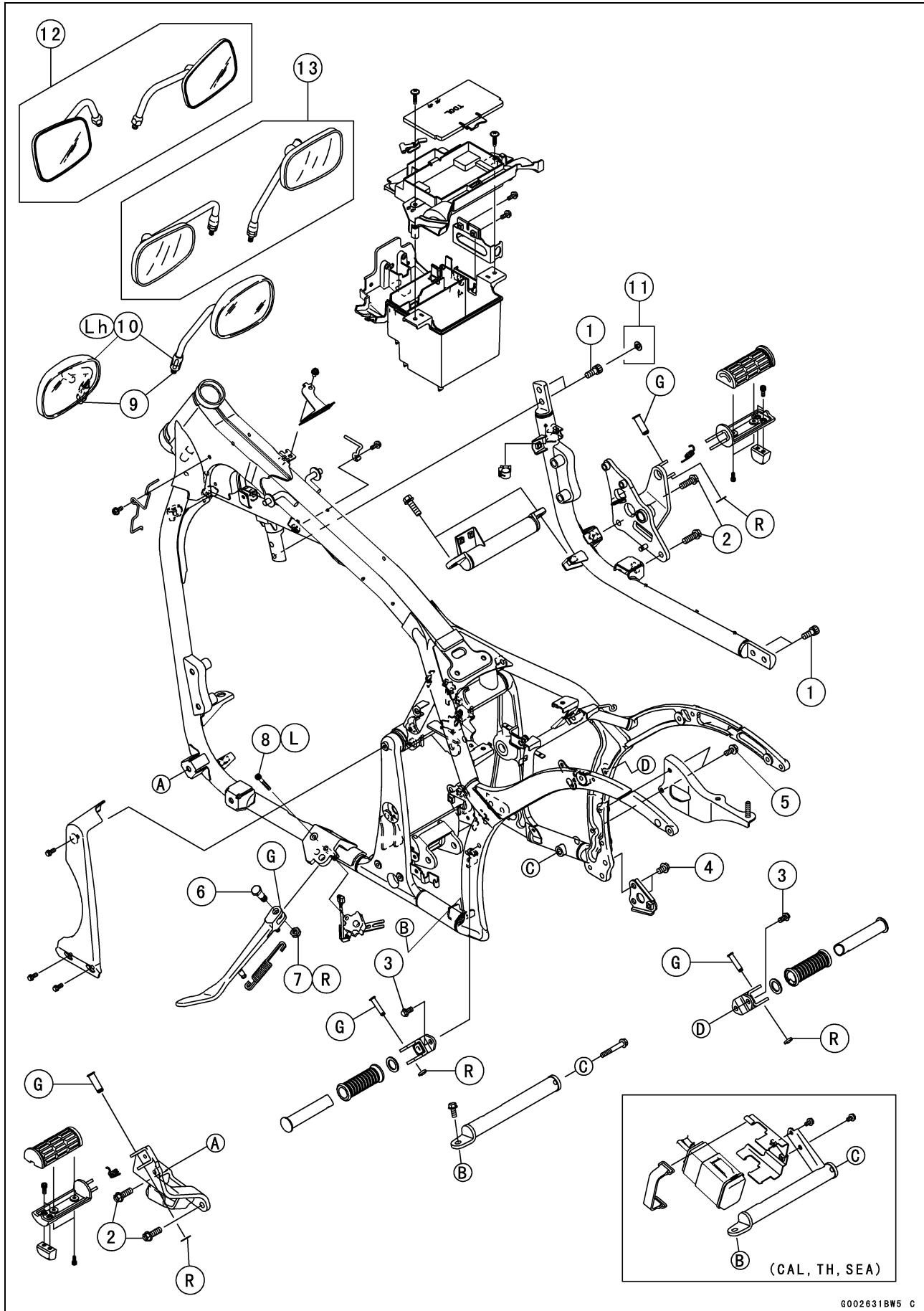

6002631BW5 C

Exploded View

| No. | Fastener | Torque | | | Remarks |
|-----|---|--------|-------|----------|---------|
| | | N·m | kgf·m | ft·lb | |
| 1 | Downtube Bolts | 44 | 4.5 | 32 | |
| 2 | Footpeg Bracket Bolts (Front) | 34 | 3.5 | 25 | |
| 3 | Footpeg Bracket Bolts (Rear) | 25 | 2.5 | 18 | |
| 4 | Muffler Bracket Bolts (Lower) | 34 | 3.5 | 25 | |
| 5 | Muffler Bracket Bolts (Upper) | 34 | 3.5 | 25 | |
| 6 | Sidestand Mounting Bolt | 44 | 4.5 | 32 | |
| 7 | Sidestand Mounting Nut | 44 | 4.5 | 32 | R |
| 8 | Sidestand Switch Mounting Bolt | 8.8 | 0.90 | 78 in·lb | L |
| 9 | Rear View Mirror (Lower Hexagonal Area) | 30 | 3.1 | 22 | |
| 10 | Rear View Mirror (Upper Hexagonal Area) | 18 | 1.8 | 13 | Lh |

11. VN900C7 ~ C9

12. Other than EUR, BR, PH and SEA-B1 Models (VN900C8 Late Models, VN900C9 ~ CD Models)

13. EUR, BR, PH and SEA-B1 Models (VN900C8 Late Models, VN900C9 ~ CD Models)

G: Apply grease.

L: Apply a non-permanent locking agent.

Lh: Left-hand threads

R: Replacement Parts

15-4 FRAME

Exploded View

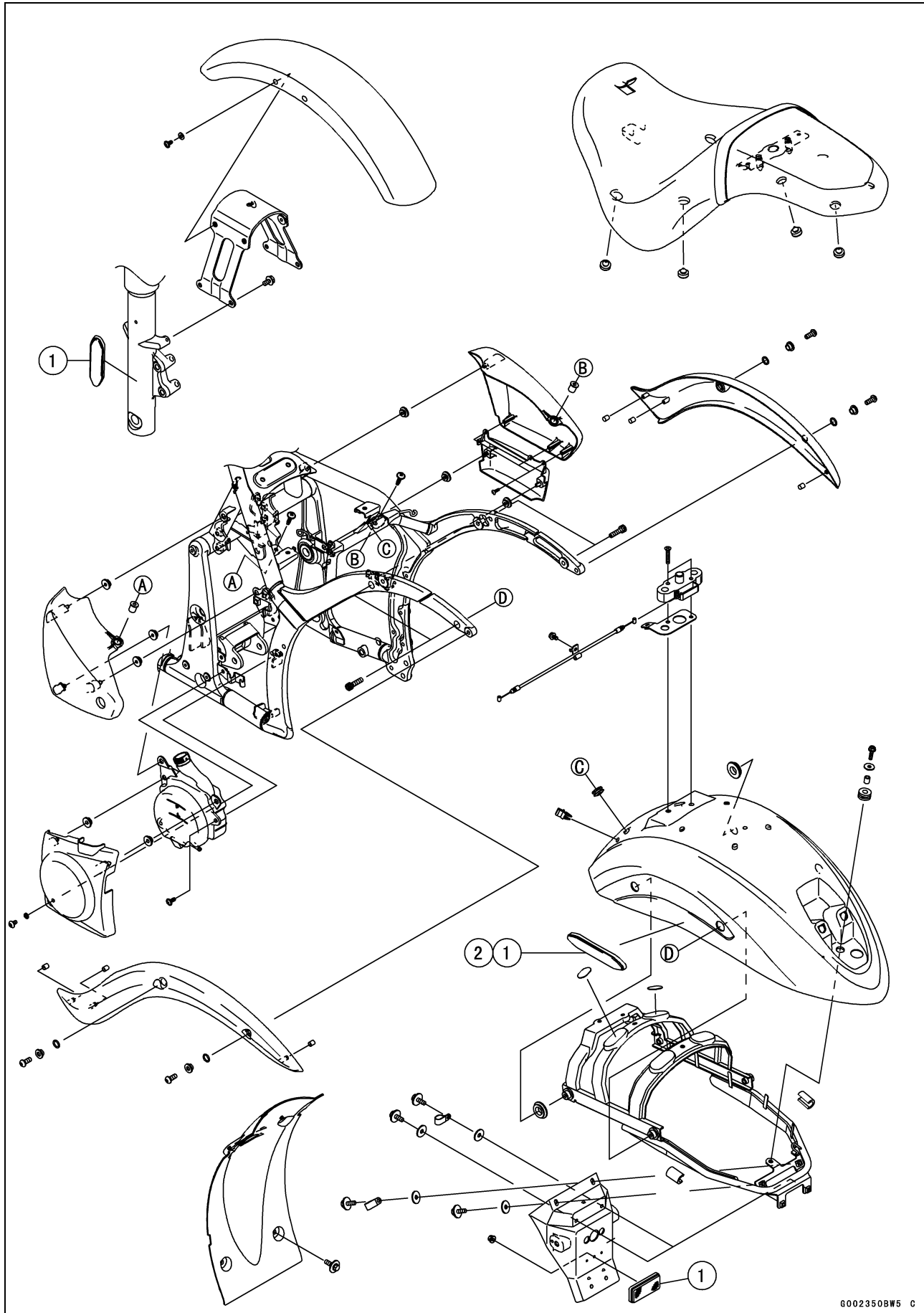

G0023508W5 C

Exploded View

1. South East Asia (VN900C8 ~ C9), United States and Canada Models
2. AU Model (VN900C9 ~ CB)

15-6 FRAME

Special Tool

Jack:

57001-1238

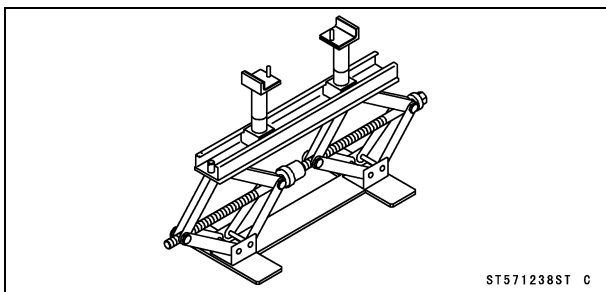

Seat

Seat Removal

- Insert the ignition switch key [A] into the seat lock, turning the key clockwise, pulling up on the rear of the seat [B], and pulling the seat backward.

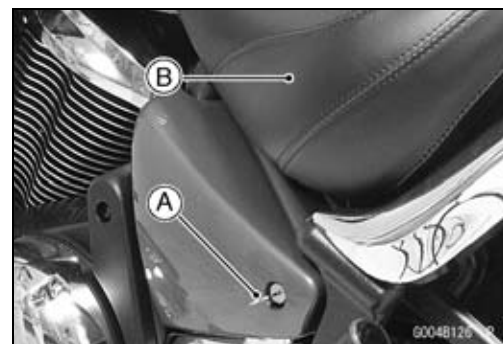

Seat Installation

- Slip the seat hook [A] under the brace [B] on the fuel tank bracket.

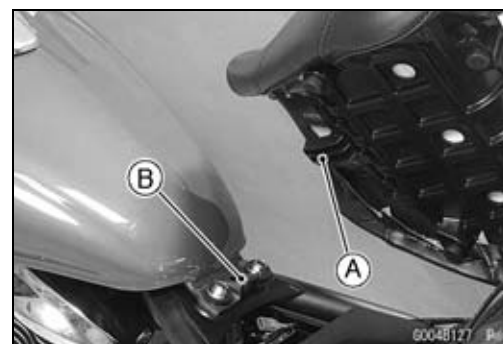

- Insert the seat latches [A] into the latch holes [B].
- Push down the rear part of the seat until the lock click.

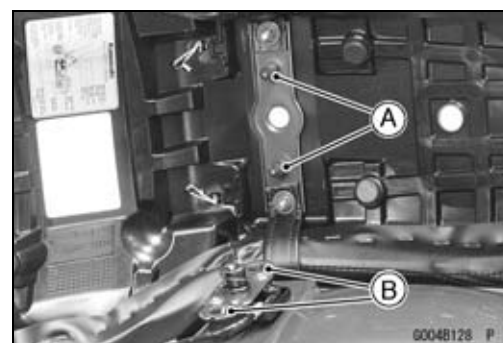

15-8 FRAME

Side Covers

Left Side Cover Removal

- Remove:
 - Seat (see Seat Removal)
 - Screw [A]

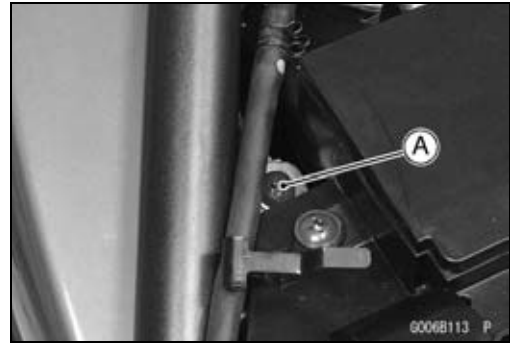

- Pull [A] the left side cover evenly, and remove it.



Left Side Cover Installation

- Put the front stoppers [A] into the grommets [B] first, then put the rear stopper [C] into the grommet [D].
- Tighten the screw.

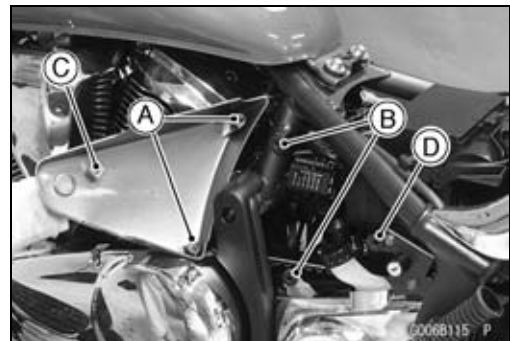

Right Side Cover Removal

- Remove:
 - Seat (see Seat Removal)
 - Screw [A]



NOTICE

Be careful not to scratch the right side cover surface with the rear muffler cover [A] during removal.

- Cover the rear muffler cover with a shop towel and pull the right side cover [B] evenly outward to clear the stoppers.



Side Covers

Right Side Cover Installation

NOTICE

Be careful not to scratch the right side cover surface with the rear muffler cover during installation.

- Put the stoppers [A] into the grommets [B].
- Tighten the screw.

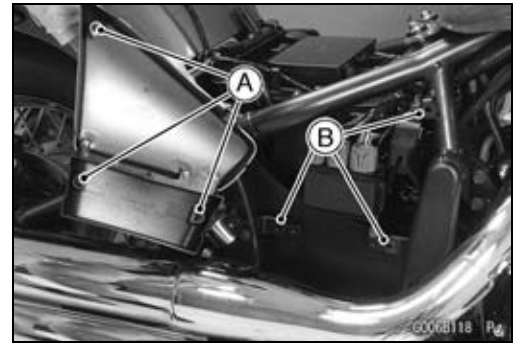

15-10 FRAME

Fenders

Front Fender Removal

NOTICE

Be careful not to scratch the painted surface during removal.

- Remove:
 - Bolts [A] and Washers (Both Sides)
 - Bolts [B] (Both Sides)
- Remove the front fender and brace forward.

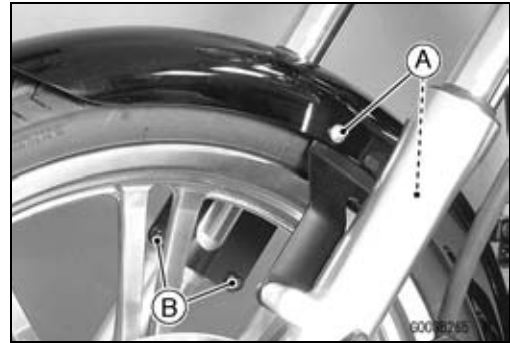

Front Fender Installation

NOTICE

Be careful not to scratch the painted surface during installation.

- Installation is the reverse of removal.

Flap and Rear Fender Removal

NOTICE

Be careful not to scratch the painted surface during removal.

- Remove:
 - Seat (see Seat Removal)
 - Bolts [A] (Both Sides)
 - Rear Fender Covers [B] (Both Sides)
- Disconnect the connectors [A].

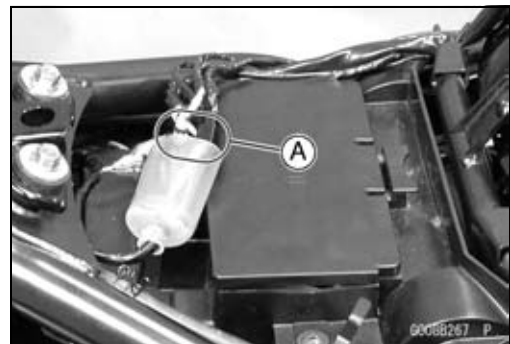
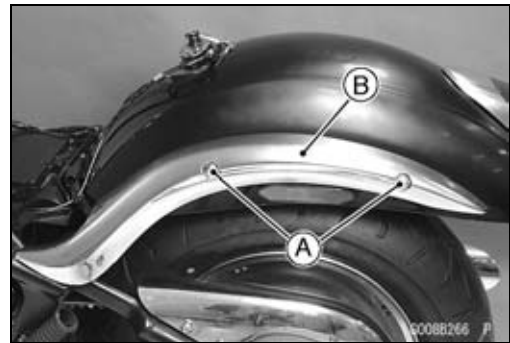

- Remove:
 - Bolt [A]
 - Seat Lock Cable Lower End [B]

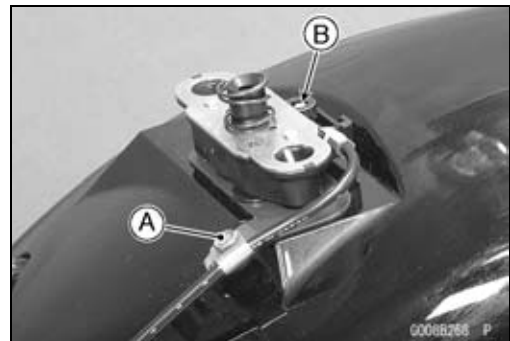

Fenders

- Remove the rear fender bolts [A] on both sides.
- Remove the rear fender [B] rearward.

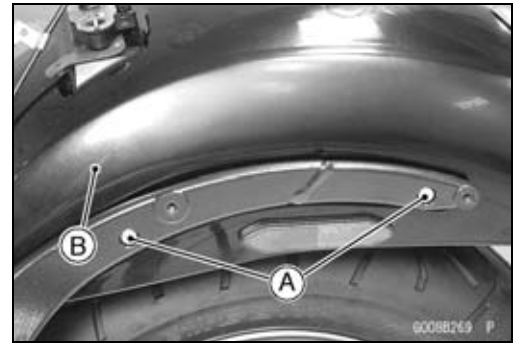

- Remove:
 - Bolts [A]
 - Flap (with License Plate Light and Turn Signal Lights) [B]

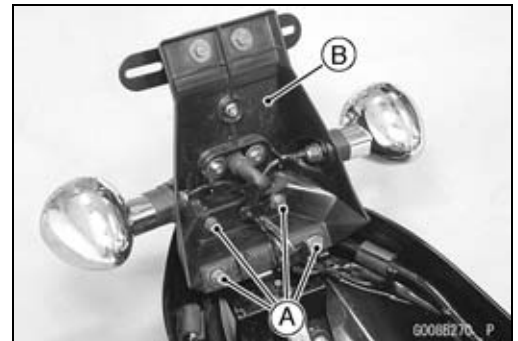

Flap and Rear Fender Installation

- Installation is the reverse of removal.
 - Put the grommet [A] of the rear fender into the stopper [B] of the frame.
 - Run the leads correctly (see Cable, Wire, and Hose Routing section in the Appendix chapter).

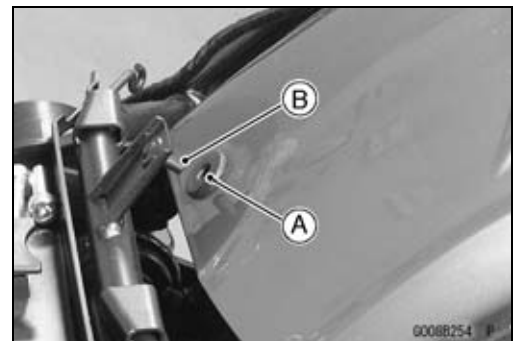

15-12 FRAME

Battery Case

Battery Case Removal

- Remove:
 - Seat (see Seat Removal)
 - Battery (see Battery Removal in the Electrical System chapter)
 - ECU (see ECU Removal in the Fuel System (DFI) chapter)
 - Relay Box (see Relay Box Removal in the Electrical System chapter)
 - Fuse Box
 - Vehicle-down Sensor [A] (see Vehicle-down Sensor Removal in the Fuel System (DFI) chapter)
 - Turn Signal Relay [B]
 - Starter Relay [C] (see Starter Relay Inspection in the Electrical System chapter)
 - Connectors [D]

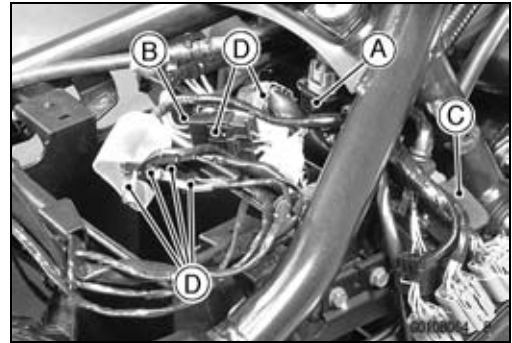

- Pry open the clamps [A] (left and right).

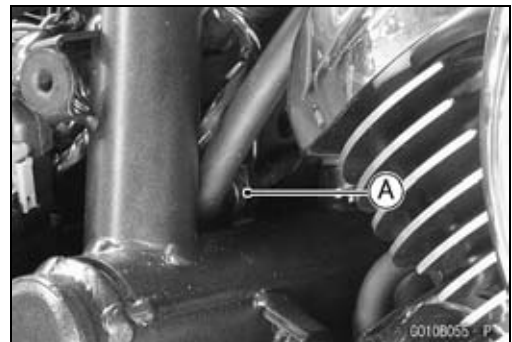

- Remove:
 - Bolts [A]
 - Relay Box Bracket [B]

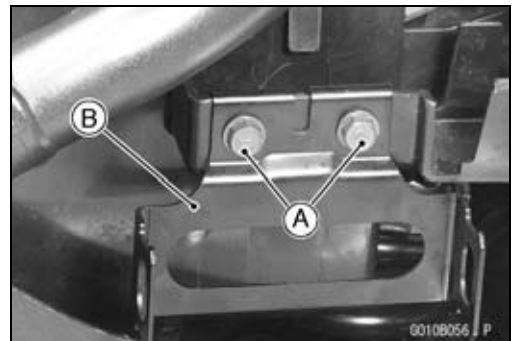

- Remove the battery case [A] upward.



Tool Box

Tool Box Removal

- Remove the seat (see Seat Removal).
- Clear the seat lock cable [A] from the hook [B].
- Remove:
 - Screws [C]
 - Tool Box [D]

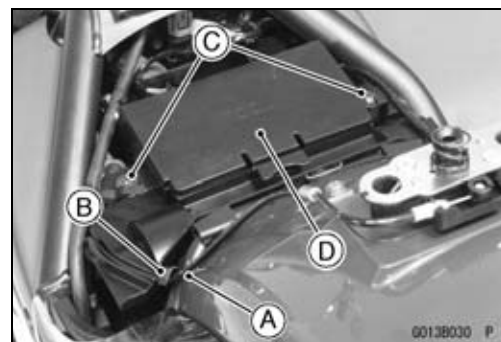

15-14 FRAME

Footpeg

Footpeg Removal/Installation

Left Side

- Remove:
 - Nut [A] and Bolt
 - Footpeg Bracket Bolts [B]
 - Left Footpeg Assembly [C]
- Install the shift pedal correctly (see Shift Pedal Installation in the Crankshaft/Transmission).
- Tighten:
 - Torque - Footpeg Bracket Bolts (Front): 34 N·m (3.5 kgf·m, 25 ft·lb)**

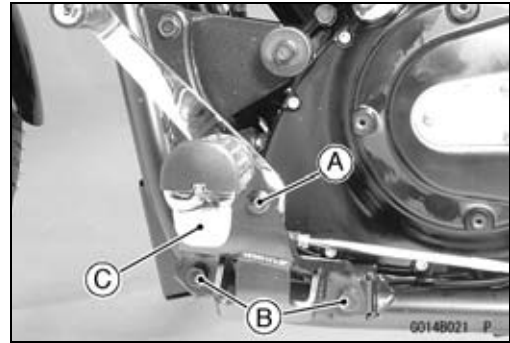

Right Side

- Remove:
 - Brake Pedal Clamp Bolt [A]
 - Brake Pedal [B]
 - Rear Master Cylinder Mounting Bolts [C]
 - Footpeg Bracket Bolts [D]
- Remove:
 - Brake Pedal Return Spring [A]
 - Brake Light Switch [B]
 - Brake Lever [C]
 - Right Footpeg Assembly [D]
- Installation is the reverse of removal.
- Install:
 - Rear Master Cylinder (see Rear Master Cylinder Installation in the Brakes chapter)
 - Brake Pedal (see Brake Pedal Installation in the Brakes chapter)
- Tighten:
 - Torque - Footpeg Bracket Bolts (Front): 34 N·m (3.5 kgf·m, 25 ft·lb)**

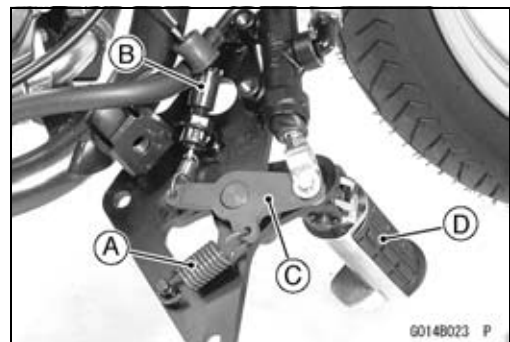
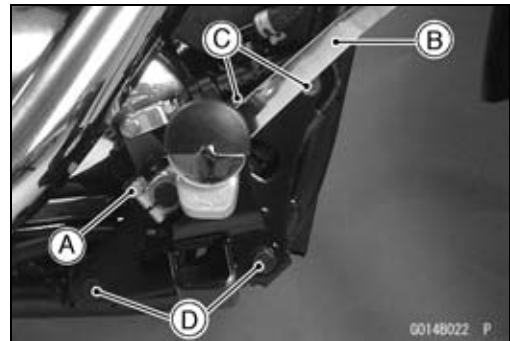

Sidestand

Sidestand Removal

- Raise the rear wheel off the ground with jack.
 - **Special Tool - Jack: 57001-1238**
- Remove the alternator outer cover (see Alternator Outer Cover Removal in the Electrical System chapter).
- Disconnect the sidestand switch lead connector [A].



- Remove:
 - Sidestand Switch Bolt [A]
 - Spring [B]
 - Sidestand Mounting Bolt [C]
 - Sidestand [D]

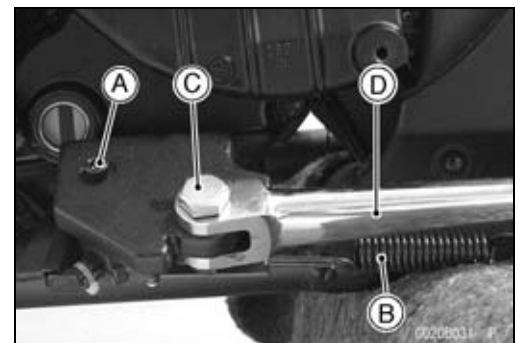

Sidestand Installation

- Apply grease to the contact surface of the frame and sidestand.
- Replace the sidestand mounting nut [C] with a new one.
- Install:
 - Sidestand [A]
 - Sidestand Mounting Bolt [B] and Nut
- Tighten:
 - **Torque - Sidestand Mounting Bolt: 44 N·m (4.5 kgf·m, 32 ft·lb)**
 - **Sidestand Mounting Nut: 44 N·m (4.5 kgf·m, 32 ft·lb)**
- Hook the spring [D] so that face the long spring end upward.
- Install the spring hook direction as shown in the figure.
- Apply a non-permanent locking agent to the threads of the sidestand switch mounting bolt [E].
- Install the sidestand switch [F].
- Tighten:
 - **Torque - Sidestand Switch Mounting Bolt: 8.8 N·m (0.90 kgf·m, 78 in·lb)**
- Check that the sidestand switch mounting bolt is not loosening.
- Run the sidestand switch lead correctly (see Cable, Wire, and Hose Routing section in the Appendix chapter).
- Install the alternator outer cover (see Alternator Outer Cover Installation in the Electrical System chapter).

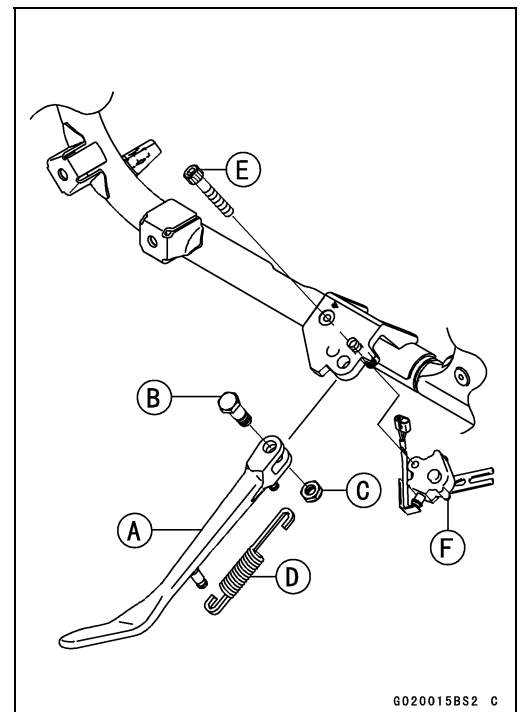

G020015BS2 C

15-16 FRAME

Rear View Mirrors

Rear View Mirror Removal (Other than EUR, BR, PH and SEA-B1 Models [VN900C8 Late Models, VN900C9 ~ CD Models])

- Loosen the locknut [A].
- Turn the rear view mirror stay [B] counterclockwise to remove the rear view mirror from the holder [C].

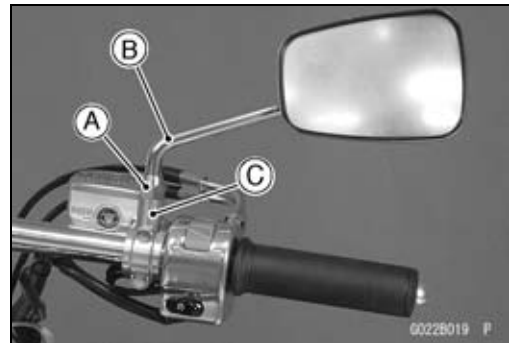

Rear View Mirror Removal (EUR, BR, PH and SEA-B1 Models [VN900C8 Late Models, VN900C9 ~ CD Models])

- Loosen the lower hexagonal area [A].
- Turn the rear view mirror stay [B] counterclockwise to remove the rear view mirror from the holder [C].

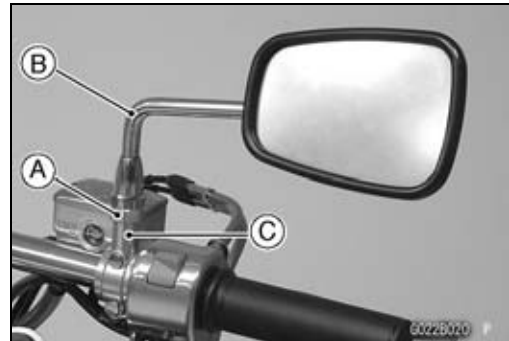

NOTICE

Do not force to tighten and/or loosen the upper hexagonal area (adapter) [A] with a pair of spanners or wrench. Disassembly of this area is not possible. Non-permanent locking agent [B] is already applied to the threads of this inner area. Forcible loosening may damage the adapter and/or the turning mechanism of the stay [C].

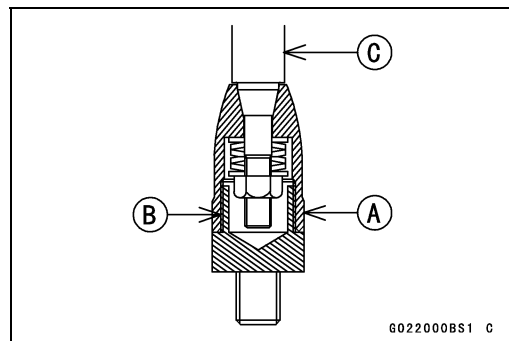

Rear View Mirror Removal (VN900CE ~ Model)

- Turn the lower hexagonal area [A] counterclockwise to remove the rear view mirror [B] from the holder [C].

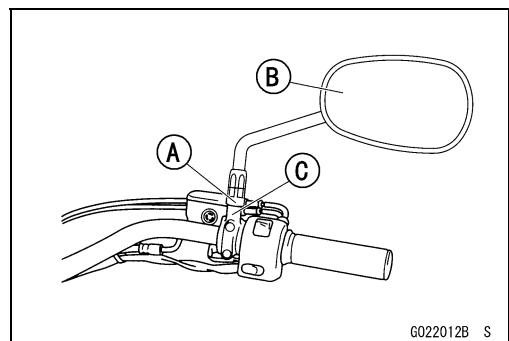

Rear View Mirror Installation (Other than EUR, BR, PH and SEA-B1 Models [VN900C8 Late Models, VN900C9 ~ CD Models])

- Loosen the locknut all the way up.
 - Screw the mounting area of the rear view mirror [A] into the holder [B] all the way, then back it two turns out.
 - Turn the stay to assure visibility to the rear with the rider sitting on the motorcycle, and tighten the locknut [C] securely.
 - Adjust the rear view mirror by slightly moving only the mirror portion of the assembly.
- Installation and adjustment of the left side are common with the those of right side. Follow the procedure specified at the right side.

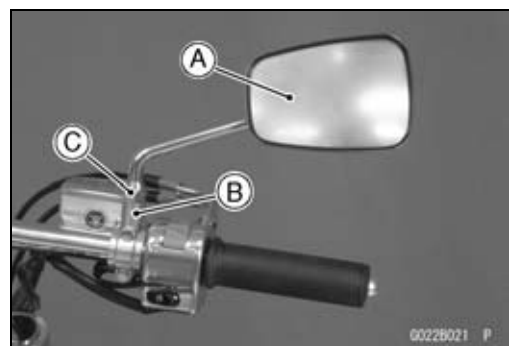

Rear View Mirrors

Rear View Mirror Installation (EUR, BR, PH and SEA-B1 Models [VN900C8 Late Models, VN900C9 ~ CD Models])

- Screw the mounting area of the rear view mirror [A] into the holder [B] all the way, and tighten the lower hexagonal area [C] securely.

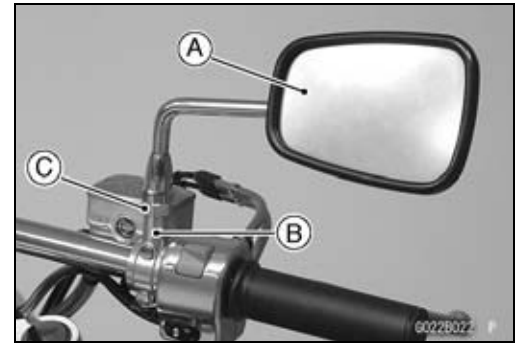

NOTICE

Do not force to tighten and/or loosen the upper hexagonal area (adapter) [A] with a pair of spanners or wrench. Disassembly of this area is not possible. Non-permanent locking agent [B] is already applied to the threads of this inner area. Forcible loosening may damage the adapter and/or the turning mechanism of the stay [C].

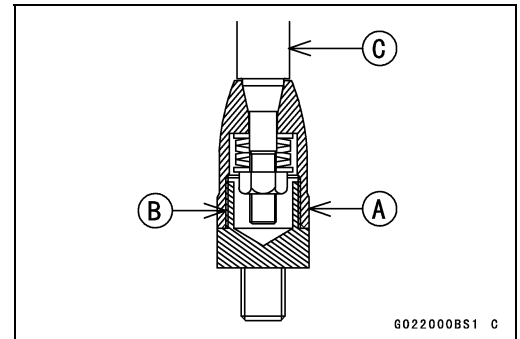

- Turn the stay [A] to assure visibility to the rear with the rider sitting on the motorcycle.
- Adjust the rear view mirror [B] by slightly moving only the mirror portion of the assembly.
- Installation and adjustment of the left side are common with the those of right side. Follow the procedure specified at the right side.

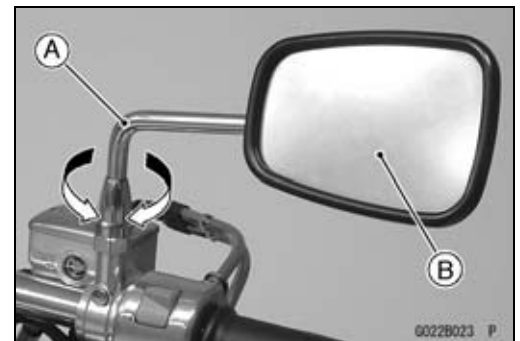

Rear View Mirror Installation (VN900CE ~ Model)

- Tighten the lower hexagonal area [A], and install the rear view mirror.

Torque - Rear View Mirror (Lower Hexagonal Area): 30 N·m (3.1 kgf·m, 22 ft·lb)

- Turn the stay [B] to assure the safe conditions of the rear with the rider sitting on the motorcycle by loosening the upper hexagonal area [C] clockwise.
- The upper hexagonal area is left-hand thread.
- Tighten the upper hexagonal area.

Torque - Rear View Mirror (Upper Hexagonal Area): 18 N·m (1.8 kgf·m, 13 ft·lb)

- Adjust the rear view mirror [D] by slightly moving only the mirror portion of the assembly.
- Installation and adjustment of the left side are common with the those of right side. Follow the procedure specified at the right side.

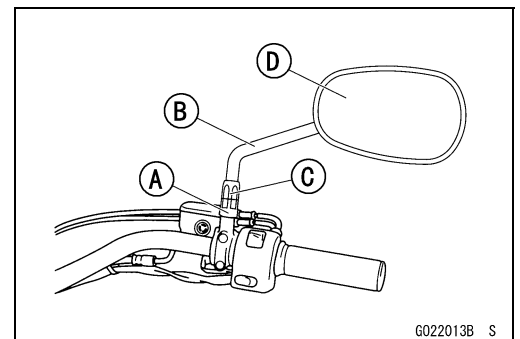

15-18 FRAME

Downtube

Downtube Removal

- Raise the rear wheel off the ground with jack.
Special Tool - Jack: 57001-1238
- Remove the fuel tank (see Fuel Tank Removal in the Fuel System (DFI) chapter).
- Disconnect the rear brake light switch connector [A].

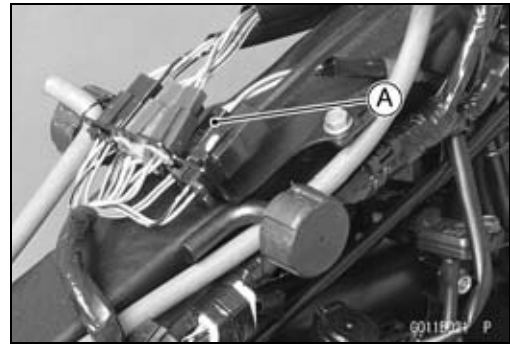

- Remove:
Bolt [A]
Clamps [B]

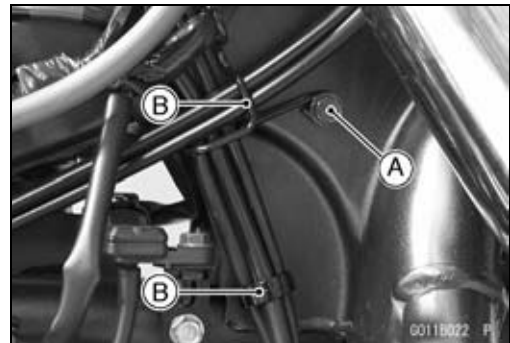

- Remove:
Front Muffler [A] (see Muffler Removal in the Engine Top End chapter)
Bolts [B]
Right Footpeg Bolts [C]

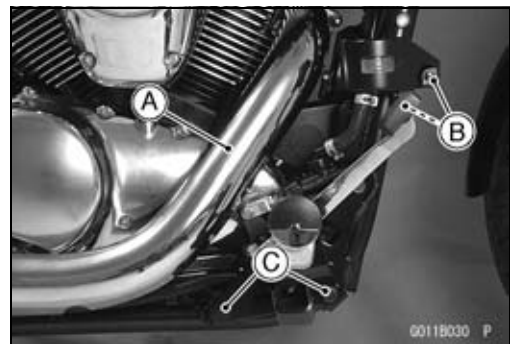

- Pry open the clamp [A].



Downtube

- Clear the brake hose [A] from the clamps [B].

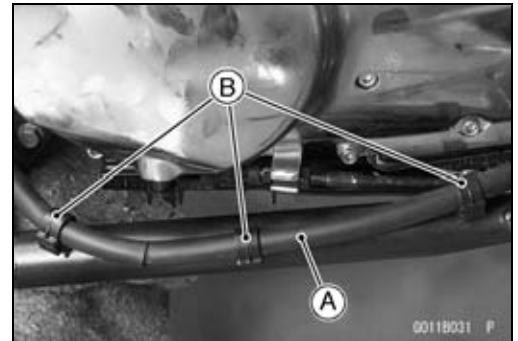

- Remove the radiator bolt [A].



- Remove:
 - Regulator/Rectifier (see Regulator/Rectifier Removal in the Electrical System chapter)
 - Front Cross Pipe Bolts [A]
 - Front Cross Pipe [B]

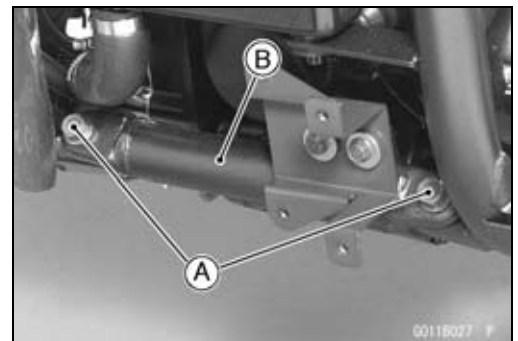

- Remove:
 - Engine Mounting Bracket Bolts [A]
 - Caps [B] (VN900C7 ~ C9) and Downtube Bolts
 - Downtube Bolts [C]
 - Downtube [D]

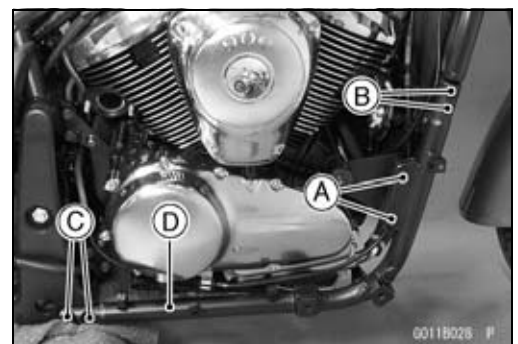

Downtube Installation

- Run the brake hose [A] on the downtube and clamps [B] it.
- Tighten:
 - Torque - Downtube Bolts: 44 N·m (4.5 kgf·m, 32 ft·lb)**
 - Engine Mounting Bracket Bolts: 44 N·m (4.5 kgf·m, 32 ft·lb)**
- Install the removed parts (see appropriate chapters).

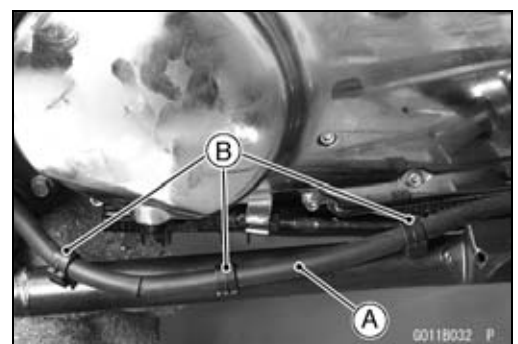

15-20 FRAME

Frame

Frame Inspection

- Visually inspect the frame [A] for cracks, dents, bending or warp.
- ★ If there is any damage to the frame, replace it.

⚠ WARNING

A repaired frame may fail in use, possibly causing an accident resulting in injury or death. If the frame is bent, dented, cracked, or warped, replace it.

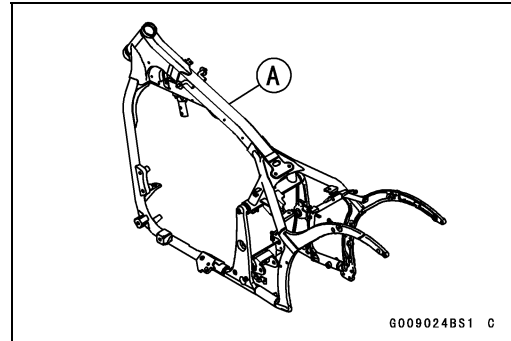

Electrical System

Table of Contents

| | |
|---|-------|
| Exploded View..... | 16-3 |
| Specifications | 16-10 |
| Special Tools and Sealant | 16-11 |
| Parts Location..... | 16-12 |
| Wiring Diagram (VN900C7 ~ C8) | 16-15 |
| Wiring Diagram (VN900C9 ~)..... | 16-24 |
| Precautions..... | 16-32 |
| Electrical Wiring..... | 16-34 |
| Wiring Inspection | 16-34 |
| Battery | 16-35 |
| Battery Removal | 16-35 |
| Battery Installation | 16-35 |
| Battery Activation | 16-35 |
| Precautions | 16-39 |
| Interchange | 16-39 |
| Charging Condition Inspection..... | 16-40 |
| Refreshing Charge..... | 16-40 |
| Charging System | 16-42 |
| Alternator Outer Cover Removal..... | 16-42 |
| Alternator Outer Cover Installation..... | 16-42 |
| Alternator Cover Removal..... | 16-42 |
| Alternator Cover Installation..... | 16-43 |
| Stator Coil Removal | 16-43 |
| Stator Coil Installation | 16-43 |
| Alternator Rotor Removal | 16-44 |
| Alternator Rotor Installation | 16-44 |
| Alternator Inspection | 16-45 |
| Regulator/Rectifier Removal | 16-47 |
| Regulator/Rectifier Inspection..... | 16-47 |
| Charging Voltage Inspection | 16-49 |
| Ignition System | 16-52 |
| Ignition Coil Removal | 16-52 |
| Ignition Coil Installation | 16-53 |
| Ignition Coil Inspection..... | 16-53 |
| Ignition Coil Primary Peak Voltage Inspection | 16-54 |
| Spark Plug Removal | 16-55 |
| Spark Plug Installation | 16-55 |
| Spark Plug Cleaning and Inspection..... | 16-55 |
| Crankshaft Sensor Removal | 16-56 |
| Crankshaft Sensor Installation | 16-56 |
| Crankshaft Sensor Inspection..... | 16-56 |
| Crankshaft Sensor Peak Voltage Inspection..... | 16-57 |
| Interlock Operation Inspection | 16-57 |
| IC Igniter Inspection | 16-58 |
| Electric Starter System | 16-62 |
| Starter Motor Removal..... | 16-62 |
| Starter Motor Installation..... | 16-62 |
| Starter Motor Disassembly..... | 16-62 |
| Starter Motor Assembly | 16-63 |
| Brush Inspection | 16-64 |

16-2 ELECTRICAL SYSTEM

| | |
|---|--------|
| Commutator Cleaning and Inspection..... | 16-64 |
| Armature Inspection..... | 16-65 |
| Brush Lead Inspection..... | 16-65 |
| Brush Plate and Terminal Bolt Inspection..... | 16-65 |
| Starter Relay Inspection..... | 16-66 |
| Lighting System..... | 16-69 |
| Headlight Beam Horizontal Adjustment..... | 16-69 |
| Headlight Beam Vertical Adjustment..... | 16-69 |
| Headlight Bulb Replacement..... | 16-69 |
| Headlight Body Removal..... | 16-70 |
| City Light Bulb Replacement (EUR, SEA-B1 (VN900CC ~), SEA-B3 (VN900CE), BR and PH Models)..... | 16-71 |
| Tail/Brake Light Removal/Installation..... | 16-71 |
| Tail/Brake Light Bulb Replacement..... | 16-72 |
| License Plate Light Bulb Replacement..... | 16-72 |
| Turn Signal Light Bulb Replacement..... | 16-75 |
| Turn Signal Relay Inspection..... | 16-76 |
| Air Switching Valve..... | 16-79 |
| Air Switching Valve Operation Test..... | 16-79 |
| Air Switching Valve Unit Test..... | 16-79 |
| Radiator Fan System..... | 16-80 |
| Fan Motor Inspection..... | 16-80 |
| Meter Unit..... | 16-82 |
| Meter Unit Removal..... | 16-82 |
| Meter Unit Installation..... | 16-82 |
| Meter Unit Disassembly..... | 16-82 |
| Meter Unit Assembly..... | 16-84 |
| Meter Unit Inspection..... | 16-84 |
| Fuel Gauge Operation Inspection..... | 16-94 |
| Switches and Sensors..... | 16-95 |
| Brake Light Timing Inspection..... | 16-95 |
| Brake Light Timing Adjustment..... | 16-95 |
| Switch Inspection..... | 16-95 |
| Water Temperature Sensor Inspection..... | 16-96 |
| Speed Sensor Removal..... | 16-96 |
| Speed Sensor Installation..... | 16-96 |
| Speed Sensor Inspection..... | 16-96 |
| Oxygen Sensor Removal (Oxygen Sensor Equipped Models)..... | 16-97 |
| Oxygen Sensor Installation (Oxygen Sensor Equipped Models)..... | 16-97 |
| Oxygen Sensor Inspection (Oxygen Sensor Equipped Models)..... | 16-97 |
| Fuel Level Sensor Inspection..... | 16-98 |
| Fuel Reserve Switch Inspection..... | 16-99 |
| Relay Box..... | 16-100 |
| Relay Box Removal..... | 16-100 |
| Relay Circuit Inspection..... | 16-100 |
| Diode Circuit Inspection..... | 16-101 |
| Fuse..... | 16-103 |
| 30 A Main Fuse Removal..... | 16-103 |
| Fuse Box Fuse Removal..... | 16-103 |
| 15 A ECU Fuse Removal..... | 16-103 |
| Fuse Installation..... | 16-104 |
| Fuse Inspection..... | 16-104 |

Exploded View

This page intentionally left blank.

16-4 ELECTRICAL SYSTEM

Exploded View

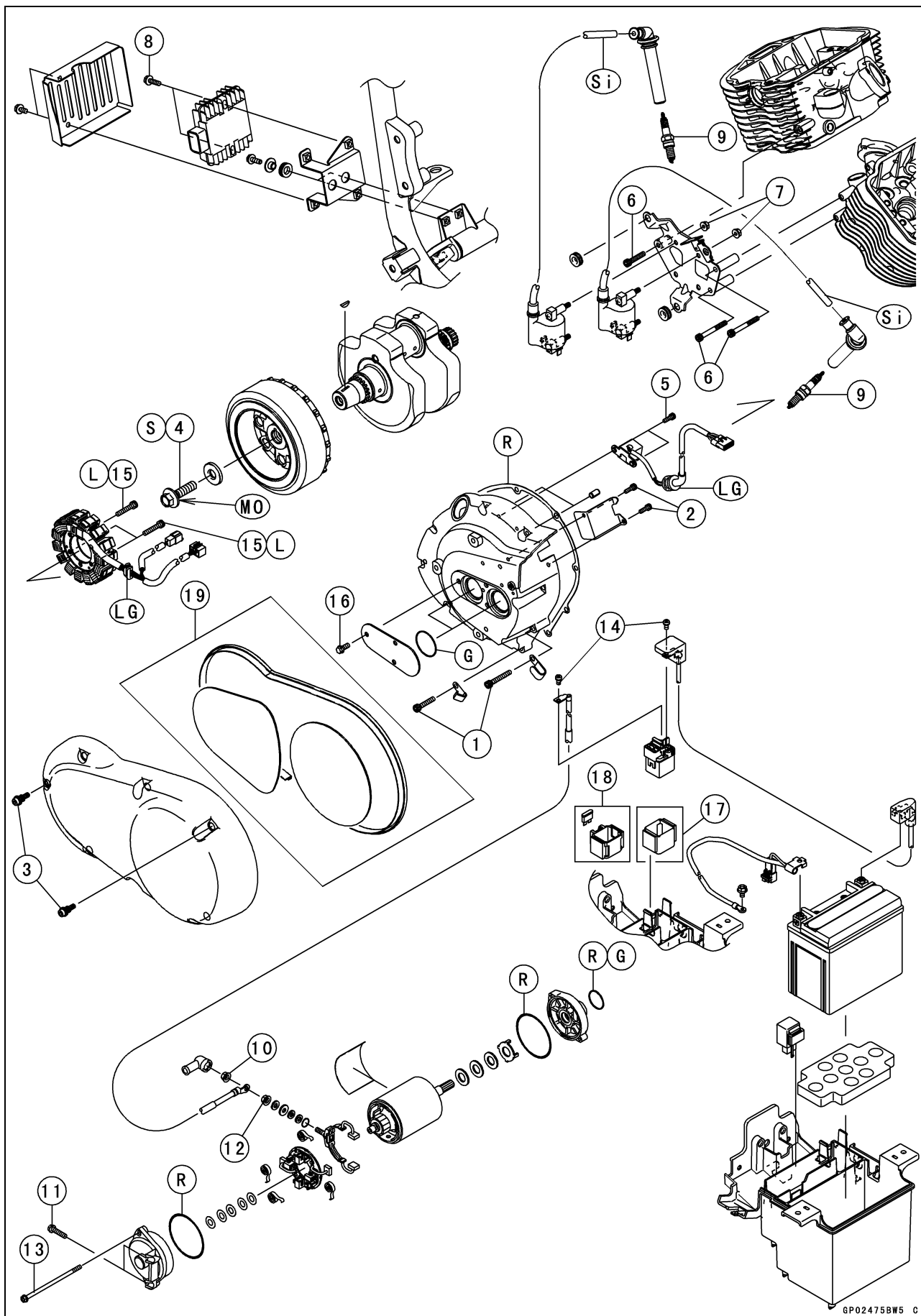

GP024758W5 C

Exploded View

| No. | Fastener | Torque | | | Remarks |
|-----|------------------------------------|--------|-------|-----------|---------|
| | | N·m | kgf·m | ft·lb | |
| 1 | Alternator Cover Bolts | 9.8 | 1.0 | 87 in·lb | |
| 2 | Alternator Lead Holder Plate Bolts | 5.9 | 0.60 | 52 in·lb | |
| 3 | Alternator Outer Cover Bolts | 9.8 | 1.0 | 87 in·lb | |
| 4 | Alternator Rotor Bolt (First) | 69 | 7.0 | 51 | MO, S |
| | Alternator Rotor Bolt (Final) | 160 | 16.3 | 118 | MO, S |
| 5 | Crankshaft Sensor Bolts | 5.9 | 0.60 | 52 in·lb | |
| 6 | Ignition Coil Bracket Bolts | 9.8 | 1.0 | 87 in·lb | |
| 7 | Ignition Coil Mounting Nuts | 6.9 | 0.70 | 61 in·lb | |
| 8 | Regulator/Rectifier Bolts | 6.9 | 0.70 | 61 in·lb | |
| 9 | Spark Plugs | 18 | 1.8 | 13 | |
| 10 | Starter Motor Cable Terminal Nut | 5.9 | 0.60 | 52 in·lb | |
| 11 | Starter Motor Mounting Bolts | 9.8 | 1.0 | 87 in·lb | |
| 12 | Starter Motor Terminal Locknut | 11 | 1.1 | 97 in·lb | |
| 13 | Starter Motor Through Bolts | 4.9 | 0.50 | 43 in·lb | |
| 14 | Starter Relay Terminal Screws | 3.9 | 0.40 | 35 in·lb | |
| 15 | Stator Coil Bolts | 12 | 1.2 | 106 in·lb | L |
| 16 | Timing Inspection Plate Bolts | 9.8 | 1.0 | 87 in·lb | |

17. VN900C7 Models, VN900C8 Early Models

18. VN900C8 Late Models, VN900C9 ~ Models

19. Other than US, CA and CAL Models (VN900C9 ~)

G: Apply grease.

L: Apply a non-permanent locking agent.

LG: Apply liquid gasket.

MO: Apply molybdenum disulfide oil solution.

(mixture of the engine oil and molybdenum disulfide grease in a weight ratio 10:1)

R: Replacement Parts

S: Follow the specified tightening sequence.

Si: Apply silicone grease.

16-6 ELECTRICAL SYSTEM

Exploded View

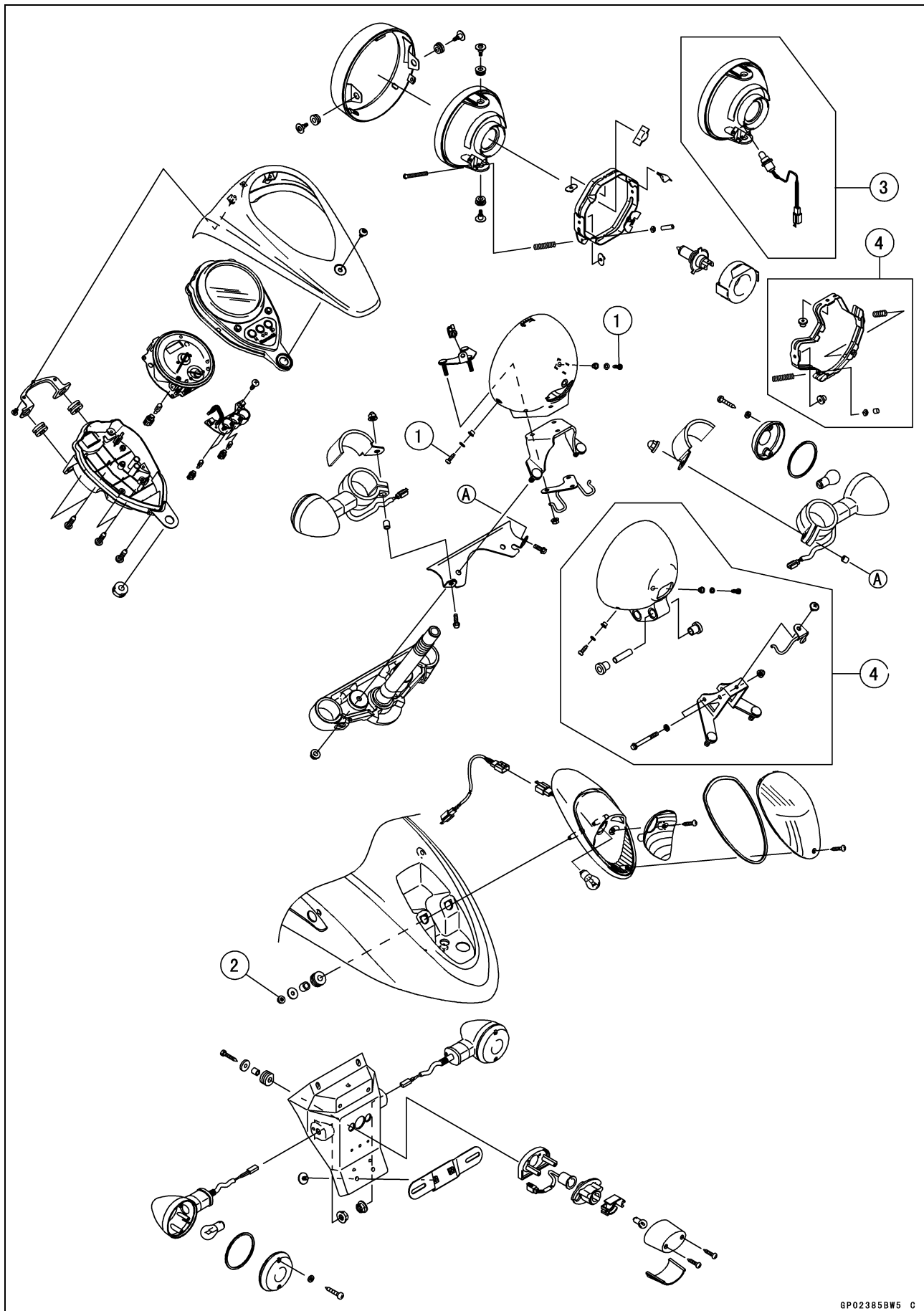

GP023858W5 C

Exploded View

| No. | Fastener | Torque | | | Remarks |
|------------|-------------------------------------|---------------|--------------|--------------|----------------|
| | | N·m | kgf·m | ft·lb | |
| 1 | Headlight Rim Screws | 2.9 | 0.30 | 26 in·lb | |
| 2 | Tail/Brake Light Unit Mounting Nuts | 5.9 | 0.60 | 52 in·lb | |

3. EUR, SEA-B1 (VN900CC ~), SEA-B3 (VN900CE), BR and PH Models

4. GB Model only

16-8 ELECTRICAL SYSTEM

Exploded View

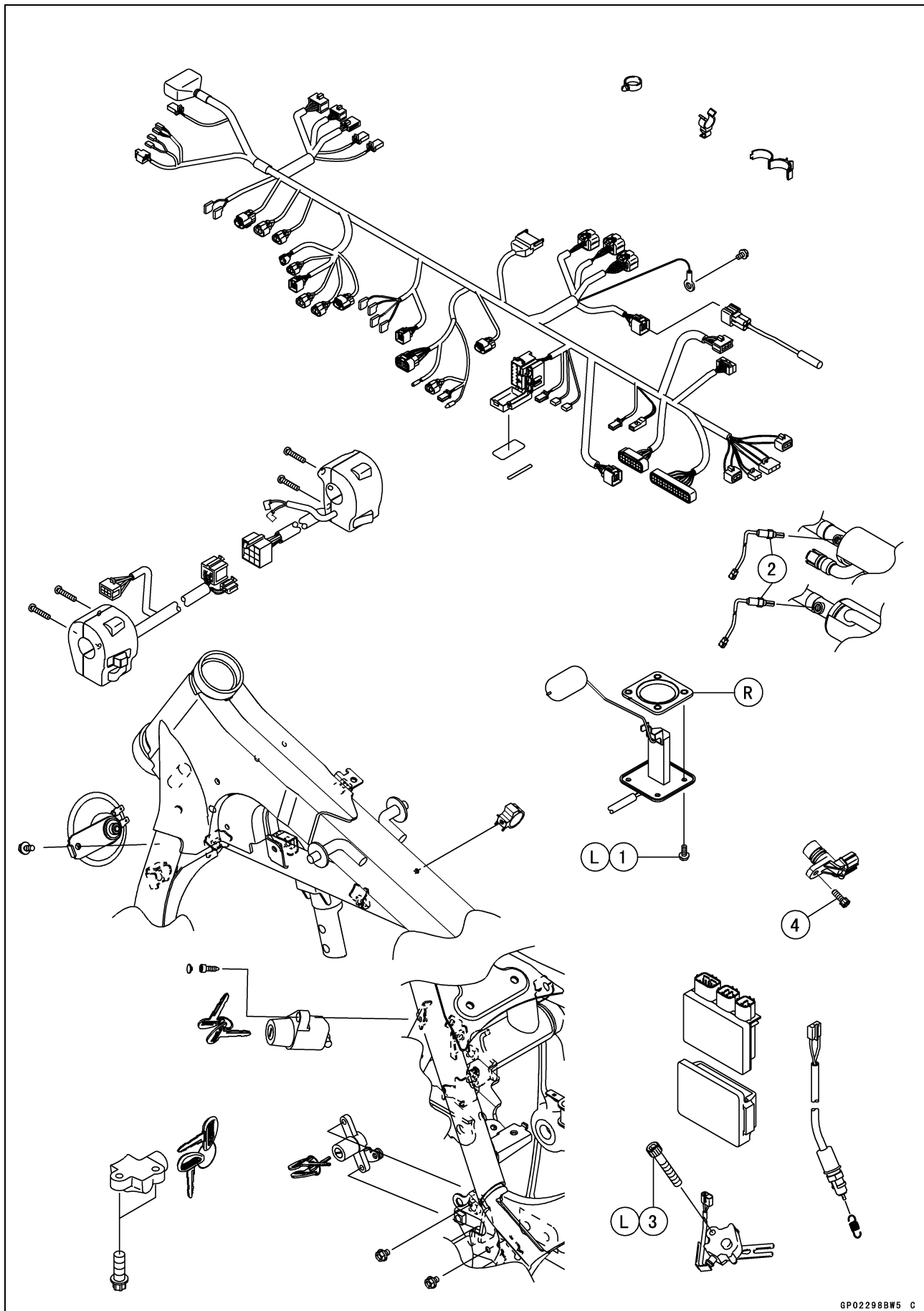

GP022988W5 C

Exploded View

| No. | Fastener | Torque | | | Remarks |
|------------|--|---------------|--------------|--------------|----------------|
| | | N·m | kgf·m | ft·lb | |
| 1 | Fuel Level Sensor Mounting Bolts | 6.9 | 0.70 | 61 in·lb | L |
| 2 | Oxygen Sensors (Oxygen Sensor Equipped Models) | 25 | 2.5 | 18 | |
| 3 | Sidestand Switch Mounting Bolt | 8.8 | 0.90 | 78 in·lb | L |
| 4 | Speed Sensor Mounting Bolt | 9.8 | 1.0 | 87 in·lb | |

L: Apply a non-permanent locking agent.

R: Replacement Parts

16-10 ELECTRICAL SYSTEM

Specifications

| Item | Standard |
|--|---|
| Battery | |
| Type | Sealed Battery |
| Model Name | YTX12-BS |
| Capacity | 12 V 10 Ah (10 HR) |
| Voltage | 12.8 V or more |
| Gross Weight | 4.2 kg (9.3 lb) |
| Electrolyte Volume | 0.60 L (37 cu in.) |
| Charging System | |
| Type | Three-phase AC |
| Alternator Output Voltage | 54 V or more at 4 000 r/min (rpm) |
| Stator Coil Resistance | 0.11 ~ 0.17 Ω |
| Charging Voltage (Regulator/Rectifier Output Voltage) | 14.2 ~ 15.2 V |
| Ignition System | |
| Crankshaft Sensor Resistance | 376 ~ 564 Ω |
| Crankshaft Sensor Peak Voltage | 2.5 V or more |
| Ignition Coil: | |
| 3 Needle Arcing Distance | 6 mm (0.24 in.) or more |
| Winding Resistance: | |
| Primary Windings | 1.9 ~ 2.9 Ω |
| Secondary Windings | 10.6 ~ 15.8 k Ω |
| Primary Peak Voltage | 184 V or more |
| Spark Plug: | |
| Type | NGK CPR7EA-9 |
| Gap | 0.8 ~ 0.9 mm (0.03 ~ 0.04 in.) |
| Electric Starter System | |
| Starter Motor: | |
| Brush Length | 12 mm (0.47 in.) (Service limit: 6.0 mm, 0.24 in.) |
| Commutator Diameter | 28 mm (1.10 in.) (Service limit: 27 mm, 1.06 in.) |
| Air Switching Valve | |
| Resistance | 18 ~ 22 Ω at 20°C (68°F) |
| Switches and Sensors | |
| Rear Brake Light Switch Timing | On after about 10 mm (0.39 in.) pedal travel |
| Engine Oil Pressure Switch Connections | When engine is stopped: ON When engine is running: OFF |
| Water Temperature Sensor Resistance | in the text |
| Fuel Level Sensor Resistance: | |
| Full Position | 4 ~ 10 Ω |
| Empty Position | 90 ~ 100 Ω |

Special Tools and Sealant

**Rotor Puller, M16/M18/M20/M22 × 1.5:
57001-1216**

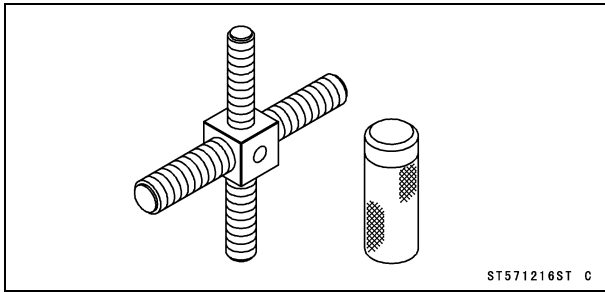

ST571216ST C

**Needle Adapter Set:
57001-1457**

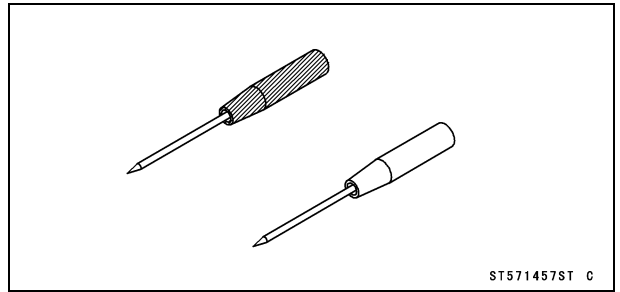

ST571457ST C

**Spark Plug Wrench, Hex 16:
57001-1262**

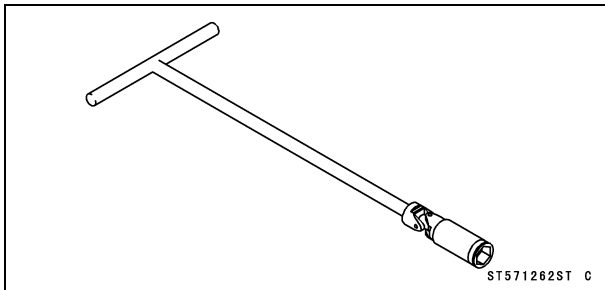

ST571262ST C

**Grip:
57001-1591**

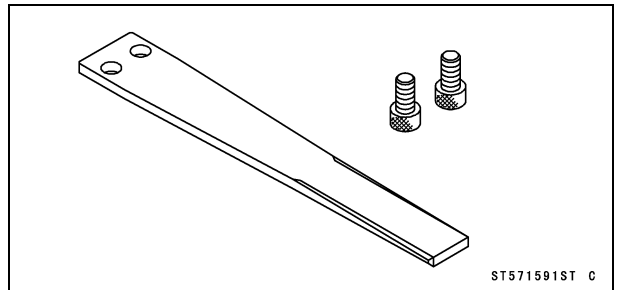

ST571591ST C

**Flywheel Puller Assembly, M38 × 1.5/M35 × 1.5:
57001-1405**

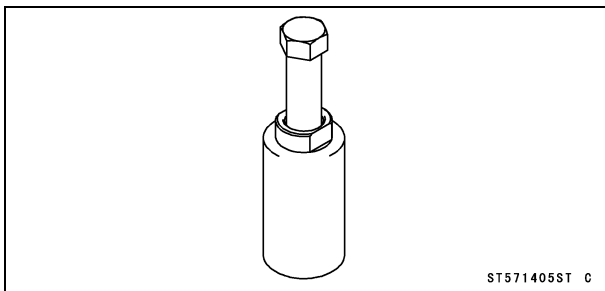

ST571405ST C

**Rotor Holder:
57001-1674**

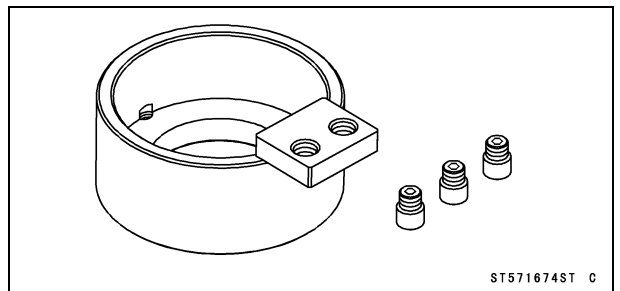

ST571674ST C

**Peak Voltage Adapter:
57001-1415**

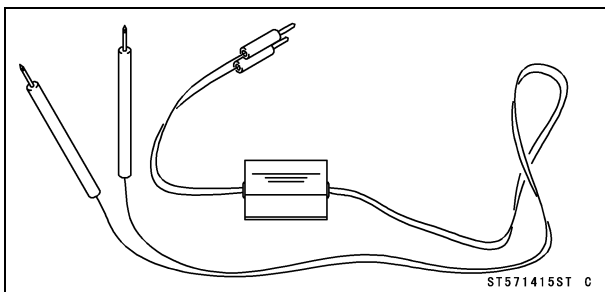

ST571415ST C

**Liquid Gasket, TB1211F:
92104-0004**

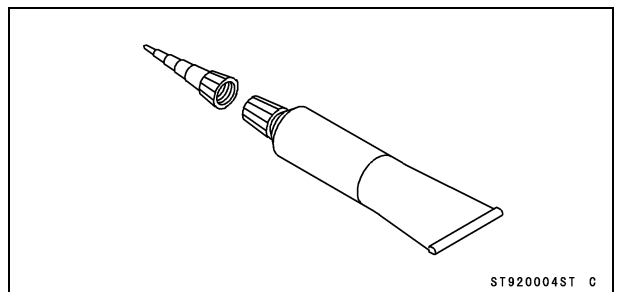

ST920004ST C

16-12 ELECTRICAL SYSTEM

Parts Location

- Left Switch Housing [A]
- Starter Lockout Switch [B]
- Headlight [C]
- Front Brake Light Switch [D]
- Right Switch Housing [E]
- Meter Unit [F]

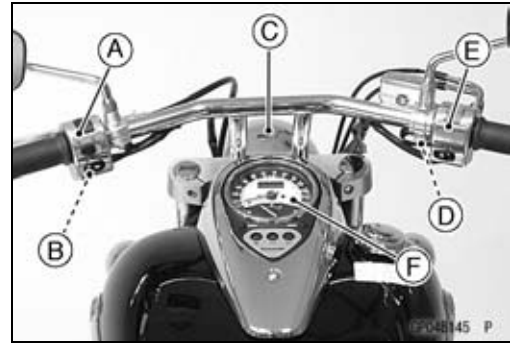

- Spark Plug [A] (Front)
- Fuel Pump [B]
- Ignition Coil [C] (Front)
- Ignition Coil [D] (Rear)
- Spark Plug [E] (Rear)

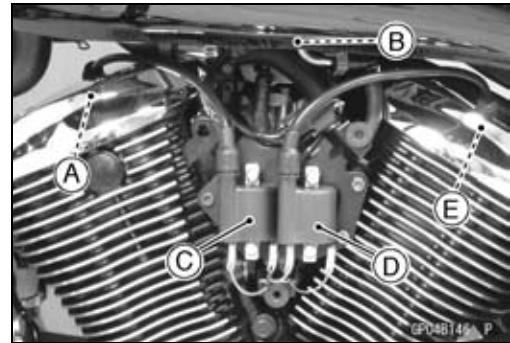

- Radiator Fan [A]
- Horn [B]

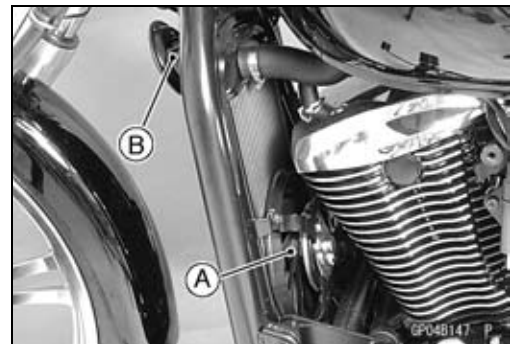

- Oil Pressure Switch [A]
- Regulator/Rectifier [B]
- Starter Motor [C]
- Alternator [D]
- Crankshaft Sensor [E]
- Stator Coil [F]

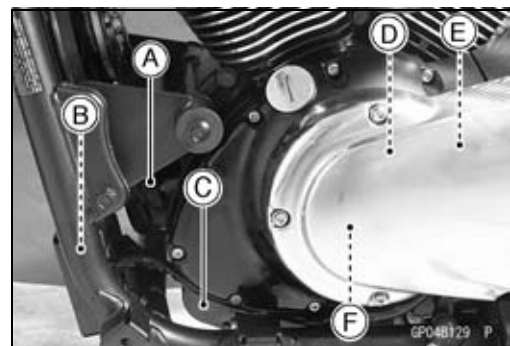

- Ignition Switch [A]
- Fuse Box [B]

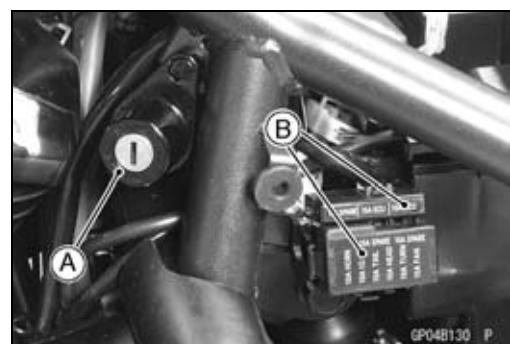

Parts Location

Speed Sensor [A]



Battery [A]
ECU (Electronic Control Unit) [B]
Turn Signal Relay [C]

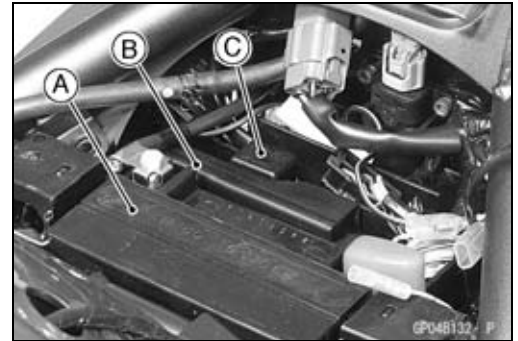

Relay Box [A]
Starter Relay and Main Fuse 30 A [B]
Frame Ground Terminal [C]

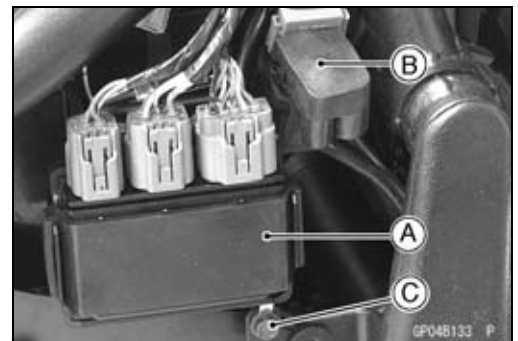

Neutral Switch [A]

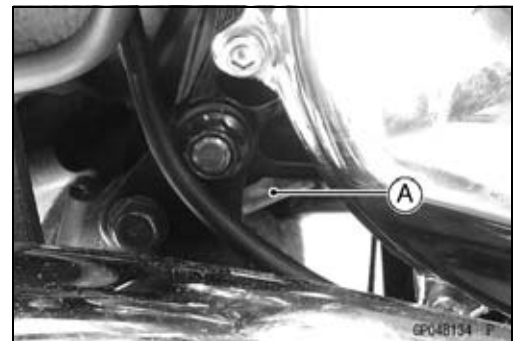

Air Switching Valve [A]



16-14 ELECTRICAL SYSTEM

Parts Location

Fuel Level Sensor [A]



Rear Brake Light Switch [A]

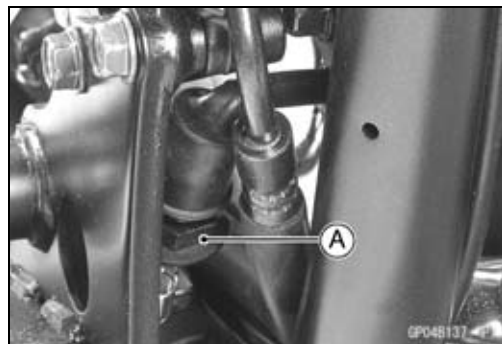

Water Temperature Sensor [A]



Sidestand Switch [A]



Wiring Diagram (VN900C7 ~ C8)

This page intentionally left blank.

16-16 ELECTRICAL SYSTEM

Wiring Diagram (VN900C7 ~ C8)

US, CA, and SEA-B1 Models

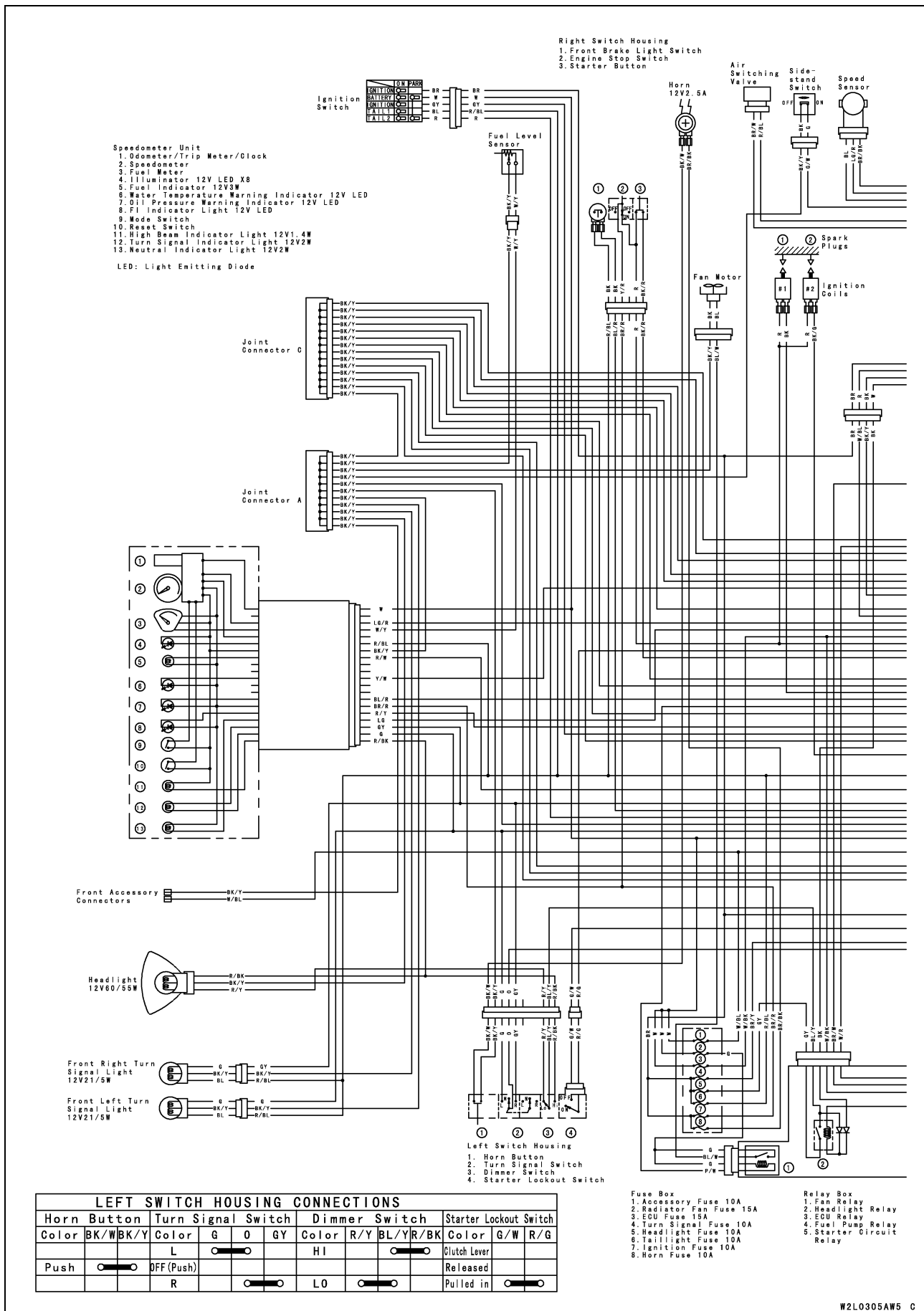

Wiring Diagram (VN900C7 ~ C8)

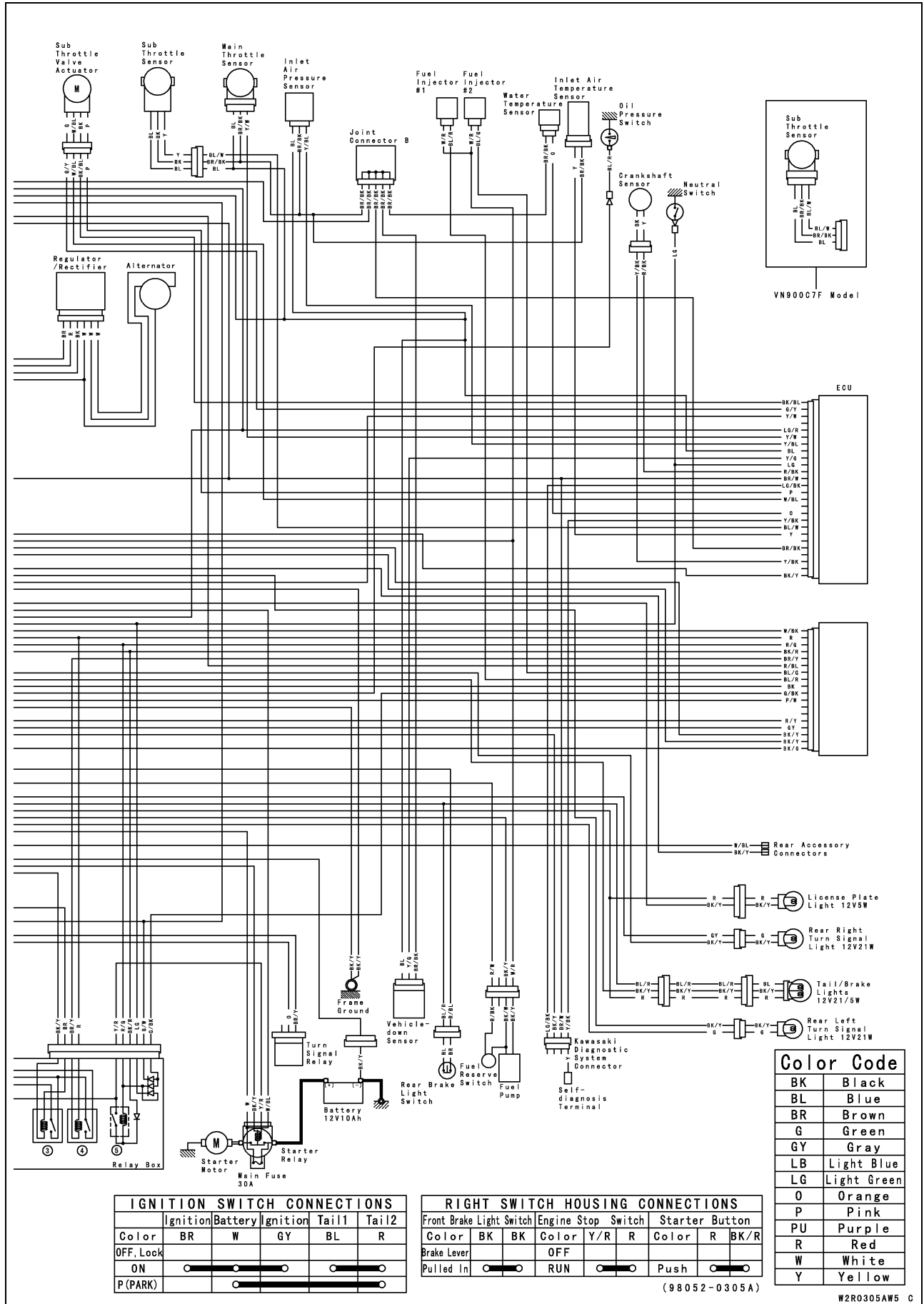

| Color Code | |
|------------|-------------|
| BK | Black |
| BL | Blue |
| BR | Brown |
| G | Green |
| GY | Gray |
| LB | Light Blue |
| LG | Light Green |
| O | Orange |
| P | Pink |
| PU | Purple |
| R | Red |
| W | White |
| Y | Yellow |

| Color | IGNITION SWITCH CONNECTIONS | | | | |
|-----------|-----------------------------|---------|----------|-------|-------|
| | Ignition | Battery | Ignition | Tail1 | Tail2 |
| OFF, Lock | BR | W | GY | BL | R |
| ON | ● | ● | ● | ● | ● |
| P (PARK) | ○ | ○ | ○ | ○ | ○ |

| RIGHT SWITCH HOUSING CONNECTIONS | | | | | | | | | |
|----------------------------------|----|----|--------------------|-----|---|----------------|---|------|---|
| Front Brake Light Switch | | | Engine Stop Switch | | | Starter Button | | | |
| Color | BK | BK | Color | Y/R | R | Color | R | BK/R | R |
| Brake Lever | ○ | ○ | OFF | ○ | ○ | Color | ○ | ○ | ○ |
| Pulled In | ○ | ○ | RUN | ○ | ○ | Push | ○ | ○ | ○ |

(98052-0305A)

W2R0305AW5 C

16-18 ELECTRICAL SYSTEM

Wiring Diagram (VN900C7 ~ C8)

EUR Models

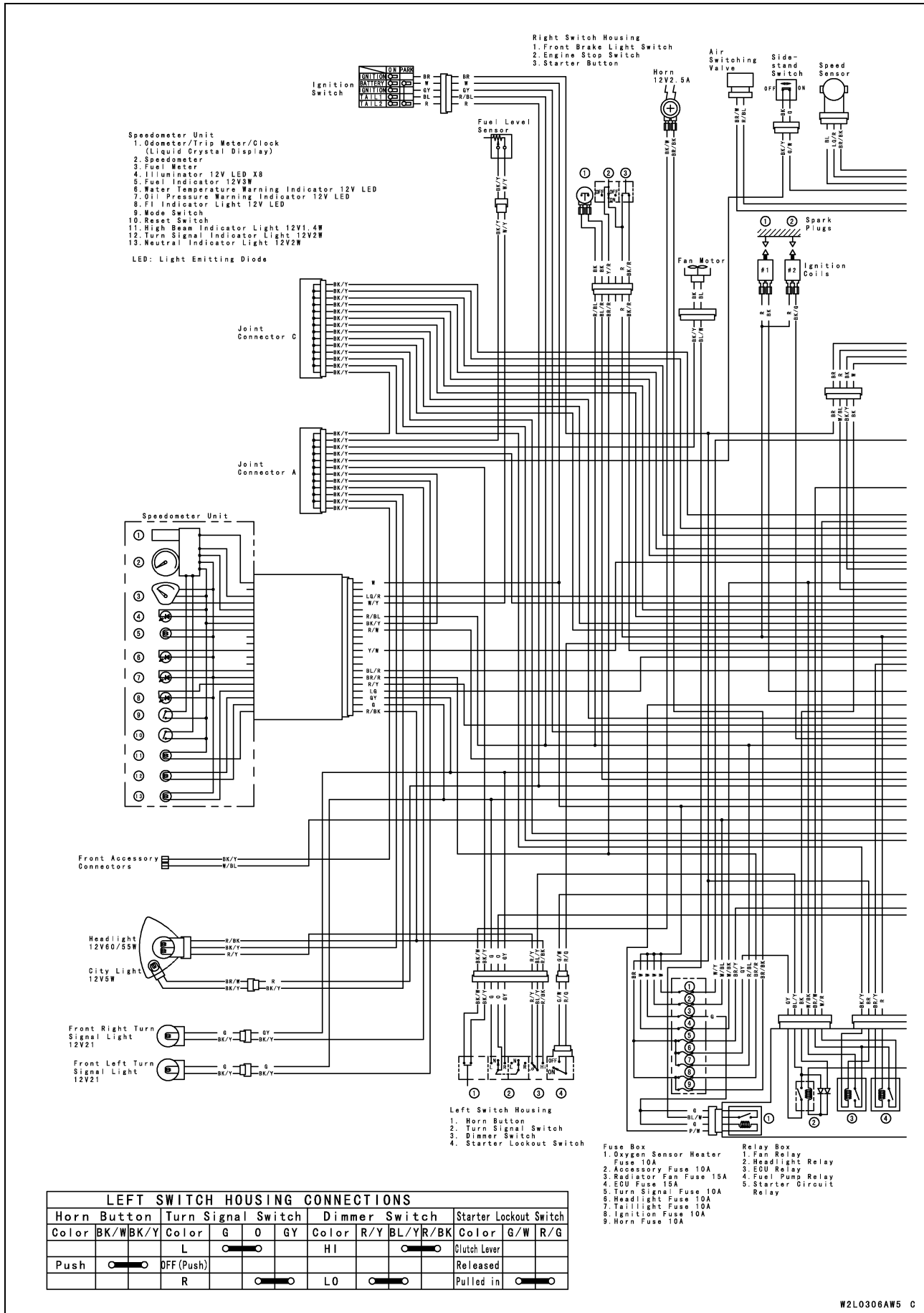

Wiring Diagram (VN900C7 ~ C8)

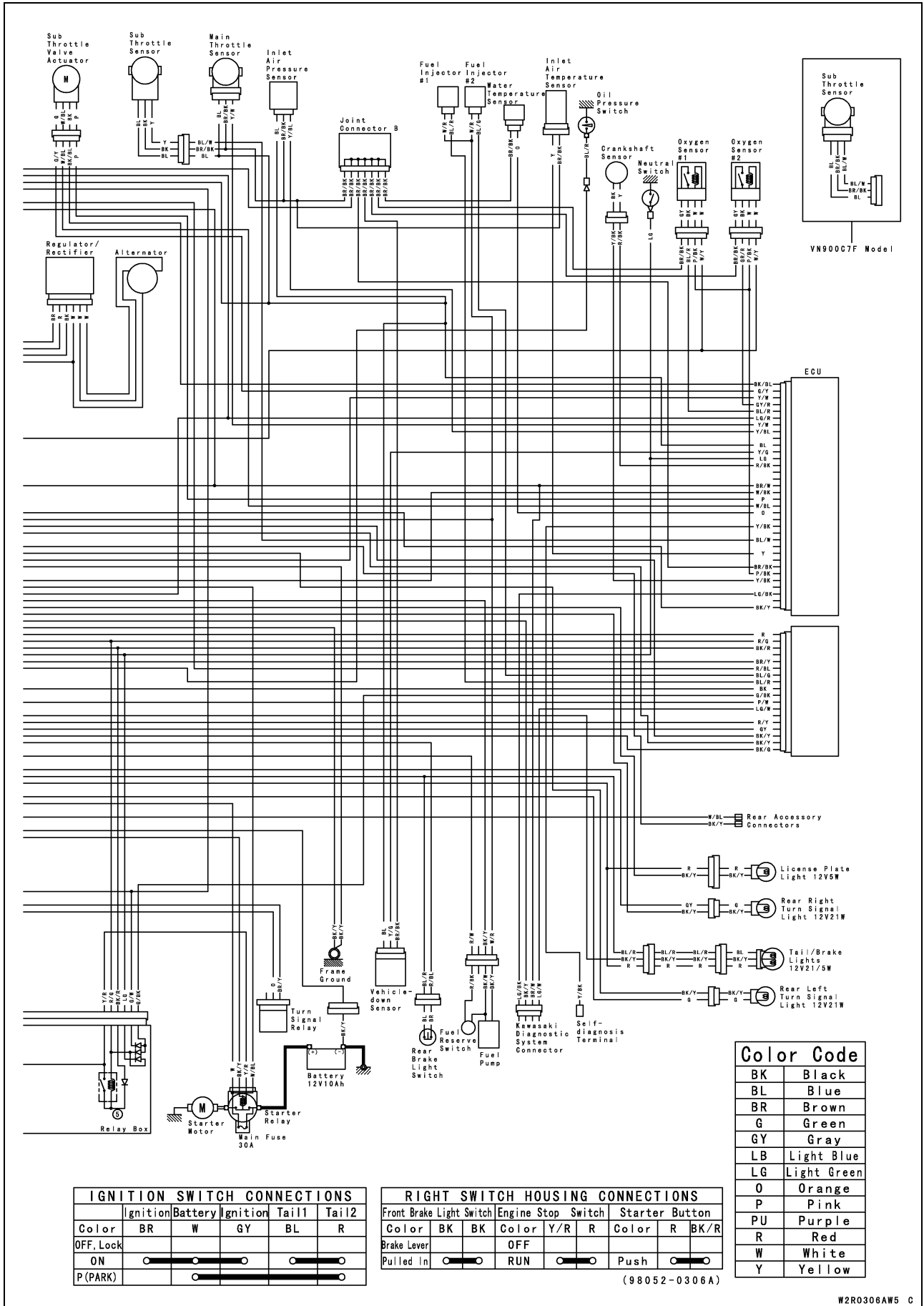

| IGNITION SWITCH CONNECTIONS | | | | | |
|-----------------------------|----------|---------|----------|-------|-------|
| | Ignition | Battery | Ignition | Tail1 | Tail2 |
| Color | BR | W | GY | BL | R |
| OFF, Lock | ● | ● | ● | ● | ● |
| ON | ● | ● | ● | ● | ● |
| P (PARK) | ● | ● | ● | ● | ● |

| RIGHT SWITCH HOUSING CONNECTIONS | | | | | |
|----------------------------------|----|--------------------|-------|----------------|------|
| Front Brake Light Switch | | Engine Stop Switch | | Starter Button | |
| Color | BK | BK | Color | Y/R | R |
| Brake Lever | ● | ● | Color | Y/R | R |
| Pulled In | ● | ● | Color | R | BK/R |
| | ● | ● | OFF | ● | ● |
| | ● | ● | RUN | ● | ● |
| | ● | ● | Push | ● | ● |

| Color Code | |
|------------|-------------|
| BK | Black |
| BL | Blue |
| BR | Brown |
| G | Green |
| GY | Gray |
| LB | Light Blue |
| LG | Light Green |
| O | Orange |
| P | Pink |
| PU | Purple |
| R | Red |
| W | White |
| Y | Yellow |

(98052-0306A)

16-20 ELECTRICAL SYSTEM

Wiring Diagram (VN900C7 ~ C8)

AU Model

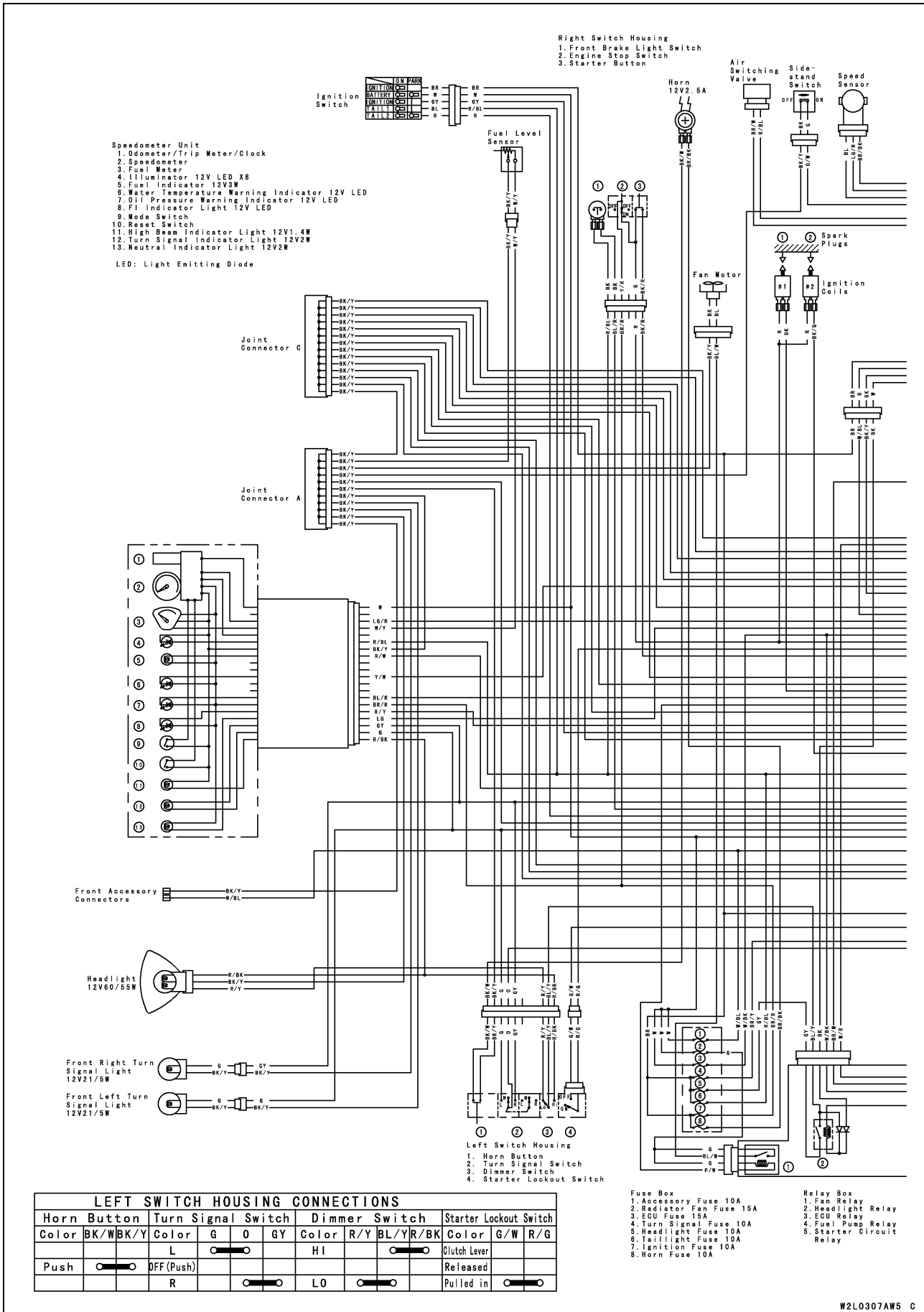

Wiring Diagram (VN900C7 ~ C8)

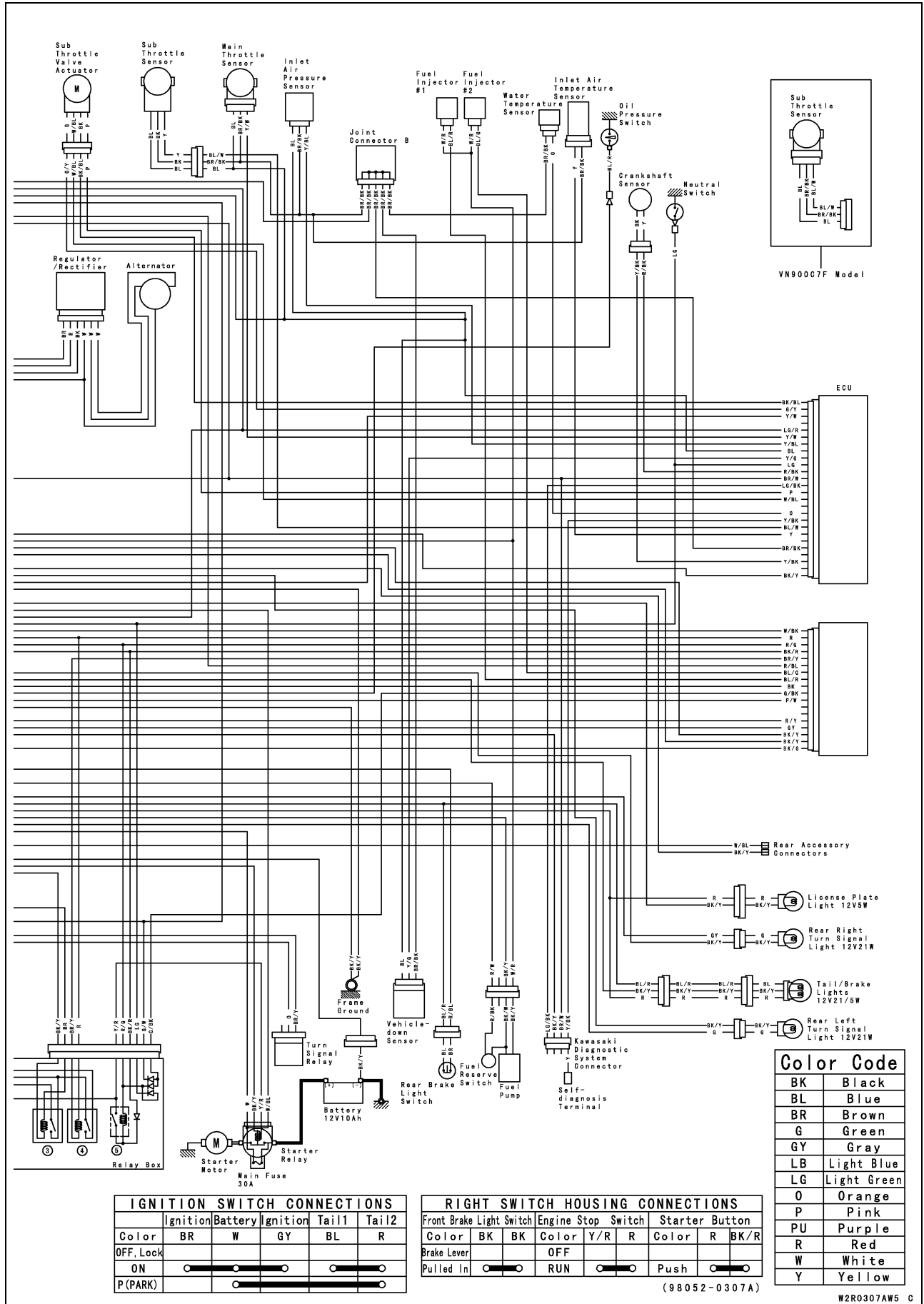

| Color Code | |
|------------|-------------|
| BK | Black |
| BL | Blue |
| BR | Brown |
| G | Green |
| GY | Gray |
| LB | Light Blue |
| LG | Light Green |
| O | Orange |
| P | Pink |
| PU | Purple |
| R | Red |
| W | White |
| Y | Yellow |

| IGNITION SWITCH CONNECTIONS | | | | | |
|-----------------------------|----------|---------|----------|-------|-------|
| Color | Ignition | Battery | Ignition | Tail1 | Tail2 |
| OFF, Lock | BR | W | GY | BL | R |
| ON | ● | ● | ● | ● | ● |
| P (PARK) | ○ | ○ | ○ | ○ | ○ |

| RIGHT SWITCH HOUSING CONNECTIONS | | | | | | | | |
|----------------------------------|----|--------------------|-------|----------------|---|-------|---|------|
| Front Brake Light Switch | | Engine Stop Switch | | Starter Button | | | | |
| Color | BK | BK | Color | Y/R | R | Color | R | BK/R |
| Brake Lever | ○ | ○ | OFF | ○ | ○ | Color | ○ | ○ |
| Pulled In | ● | ● | RUN | ● | ● | Push | ● | ● |

(98052-0307A)

W2R0307AW5 C

16-22 ELECTRICAL SYSTEM

Wiring Diagram (VN900C7 ~ C8)

TH Model

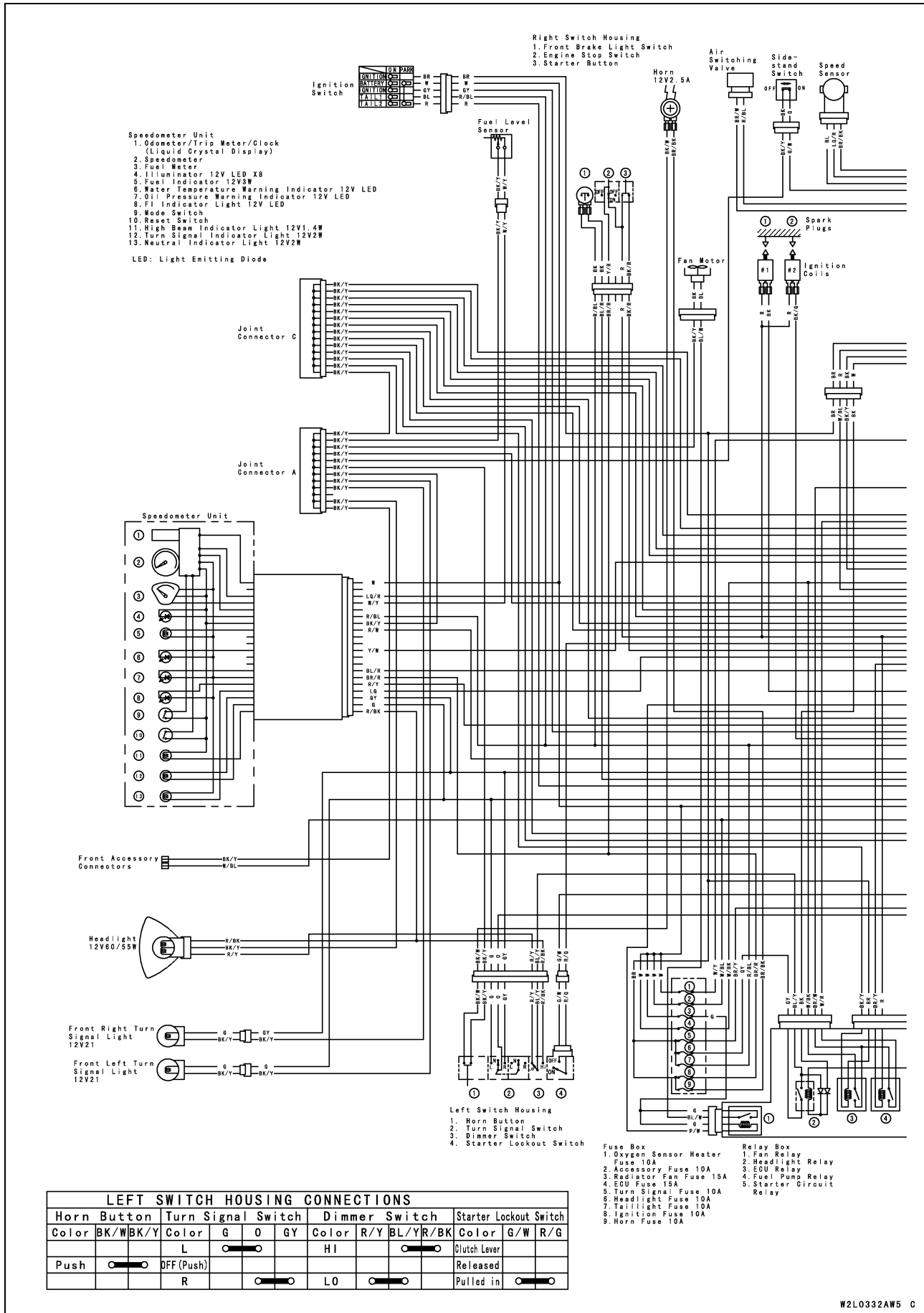

Wiring Diagram (VN900C7 ~ C8)

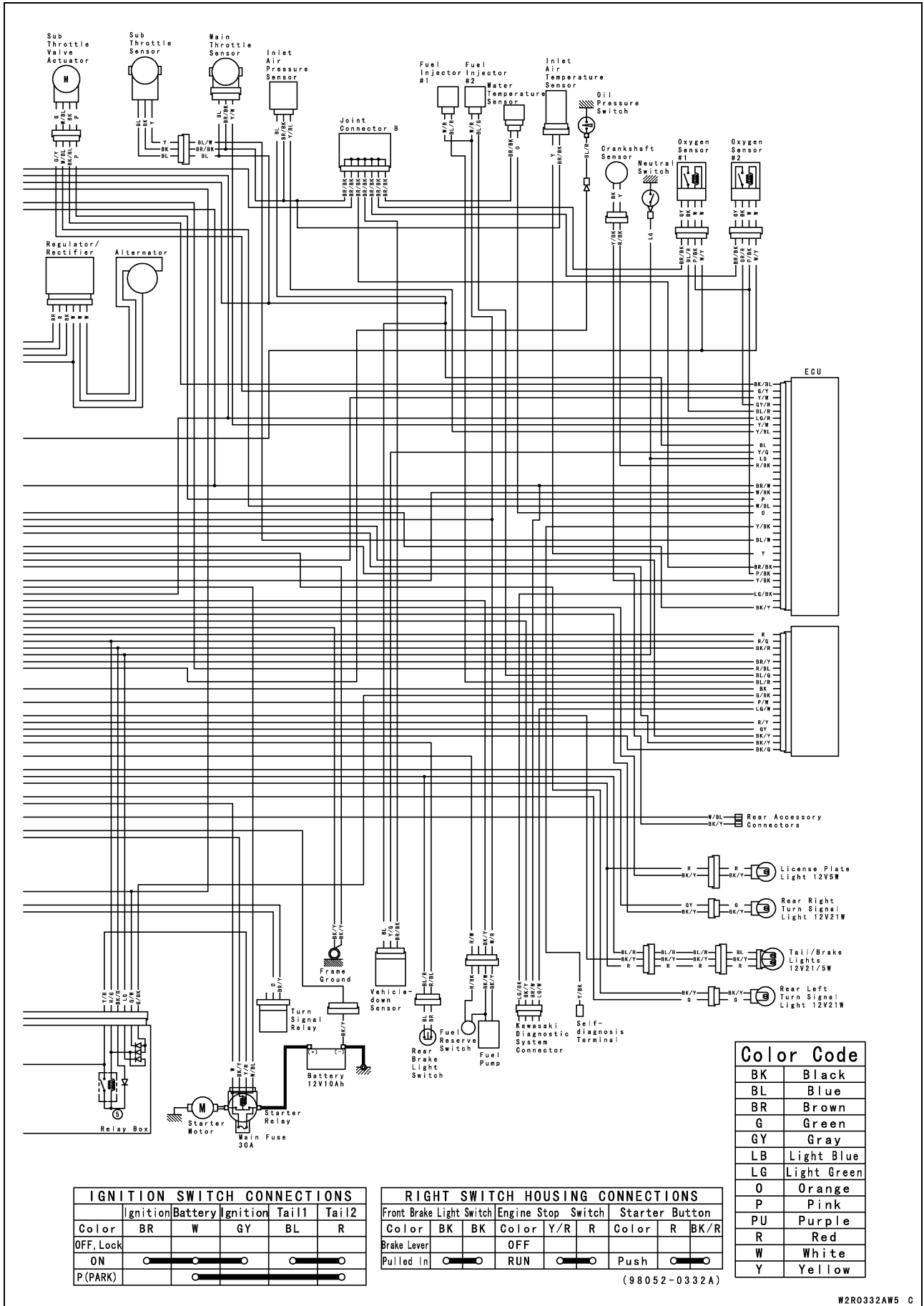

16-24 ELECTRICAL SYSTEM

Wiring Diagram (VN900C9 ~)

US and CA Models

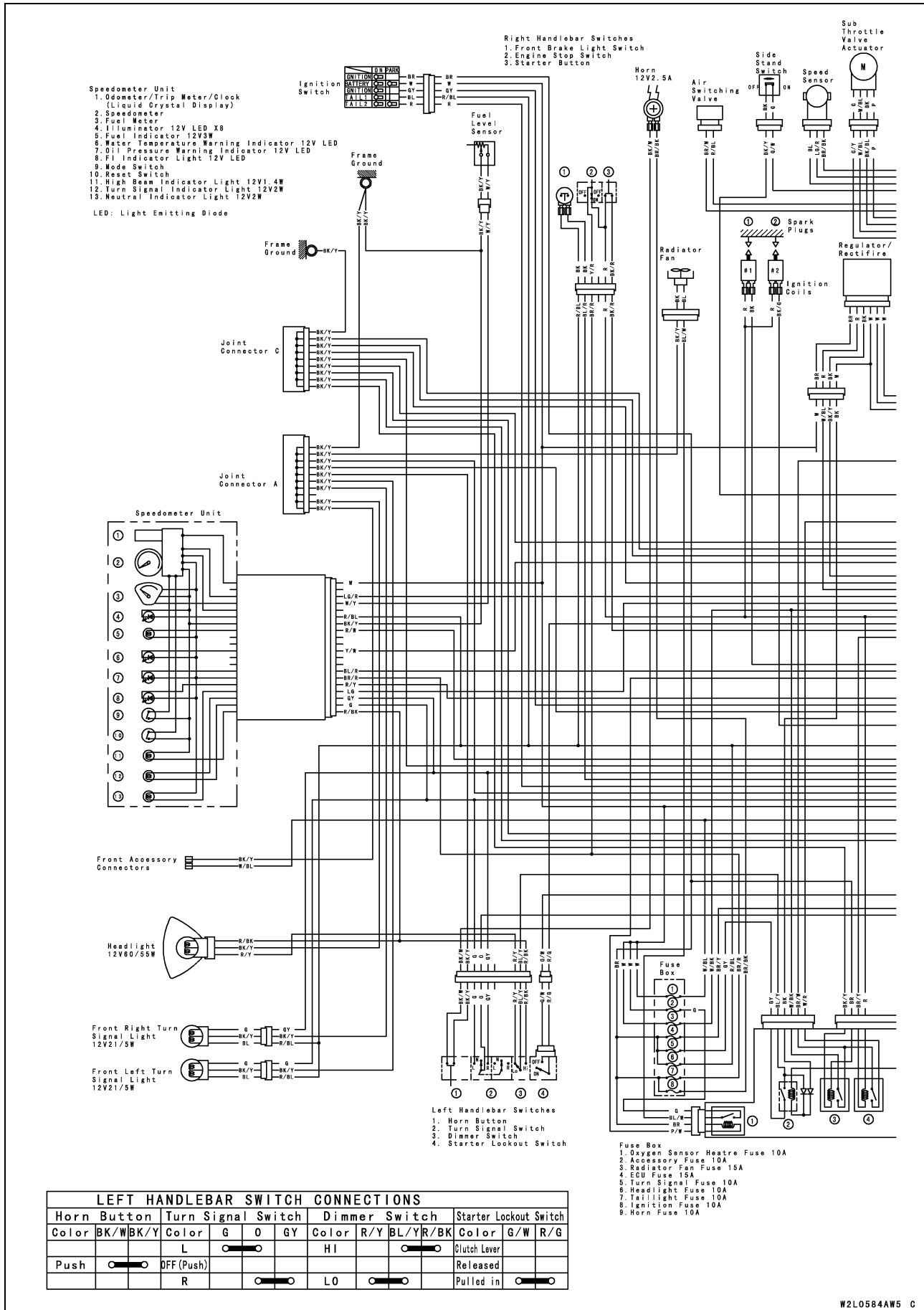

Wiring Diagram (VN900C9 ~)

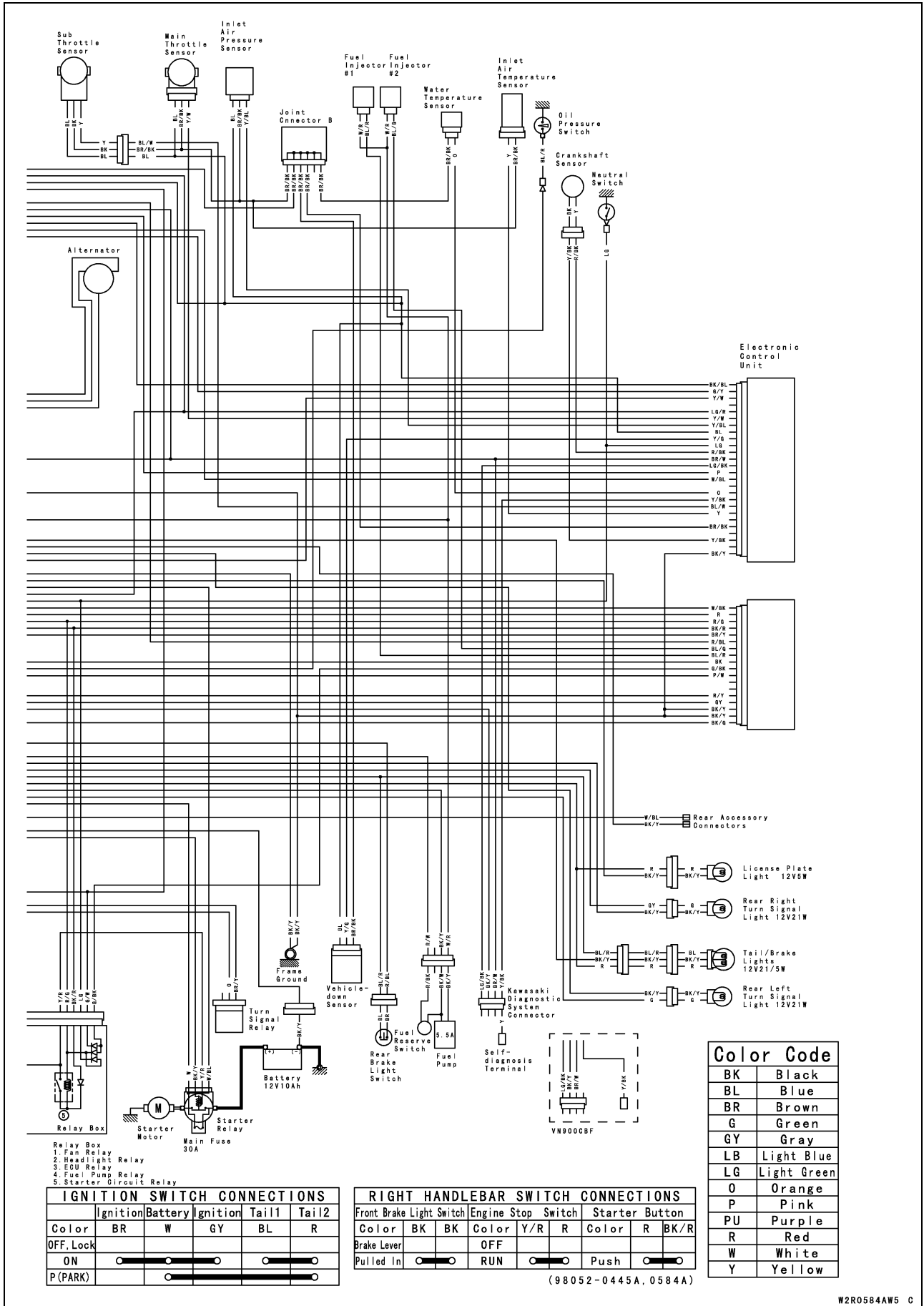

- Relay Box
- 1. Fan Relay
- 2. Headlight Relay
- 3. ECU Relay
- 4. Fuel Pump Relay
- 5. Starter Circuit Relay

| IGNITION SWITCH CONNECTIONS | | | | | |
|-----------------------------|-----------------------------------|---------|----------|-------|-------|
| | Ignition | Battery | Ignition | Tail1 | Tail2 |
| Color | BR | W | GY | BL | R |
| OFF, Lock | [Diagram showing switch contacts] | | | | |
| ON | [Diagram showing switch contacts] | | | | |
| P (PARK) | [Diagram showing switch contacts] | | | | |

| RIGHT HANDLEBAR SWITCH CONNECTIONS | | | | | |
|------------------------------------|-----------------------------------|--------------------|-----------------------------------|----------------|-----------------------------------|
| Front Brake Light Switch | | Engine Stop Switch | | Starter Button | |
| Color | BK BK | Color | Y/R R | Color | R BK/R |
| Brake Lever | OFF | Color | Y/R R | Color | R BK/R |
| Pulled In | [Diagram showing switch contacts] | RUN | [Diagram showing switch contacts] | Push | [Diagram showing switch contacts] |

| Color Code | |
|------------|-------------|
| BK | Black |
| BL | Blue |
| BR | Brown |
| G | Green |
| GY | Gray |
| LB | Light Blue |
| LG | Light Green |
| O | Orange |
| P | Pink |
| PU | Purple |
| R | Red |
| W | White |
| Y | Yellow |

(98052-0445A, 0584A)

16-26 ELECTRICAL SYSTEM

Wiring Diagram (VN900C9 ~)

EUR, SEA-B1 (VN900CC ~), SEA-B3 (VN900CE), BR and PH Models

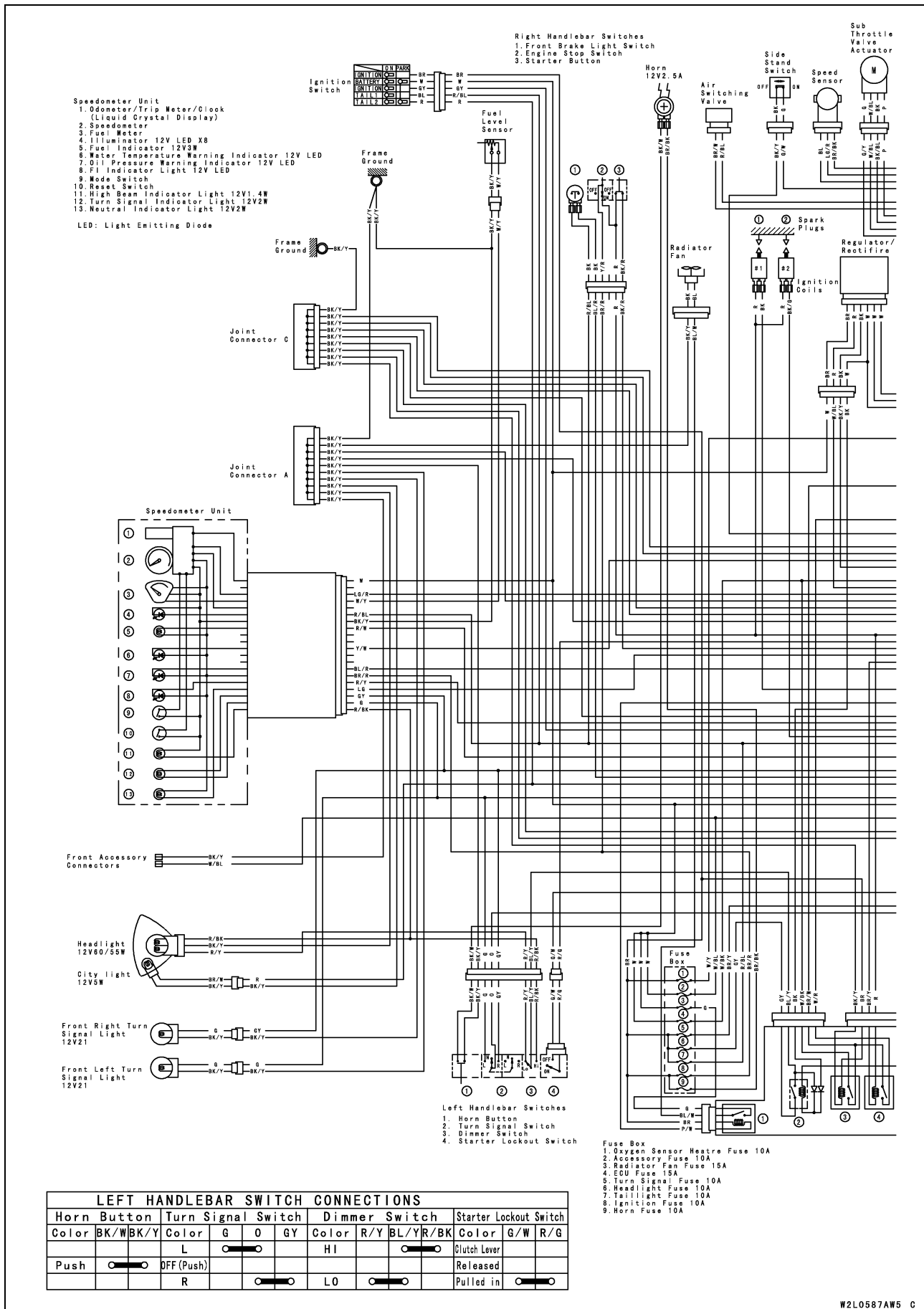

Wiring Diagram (VN900C9 ~)

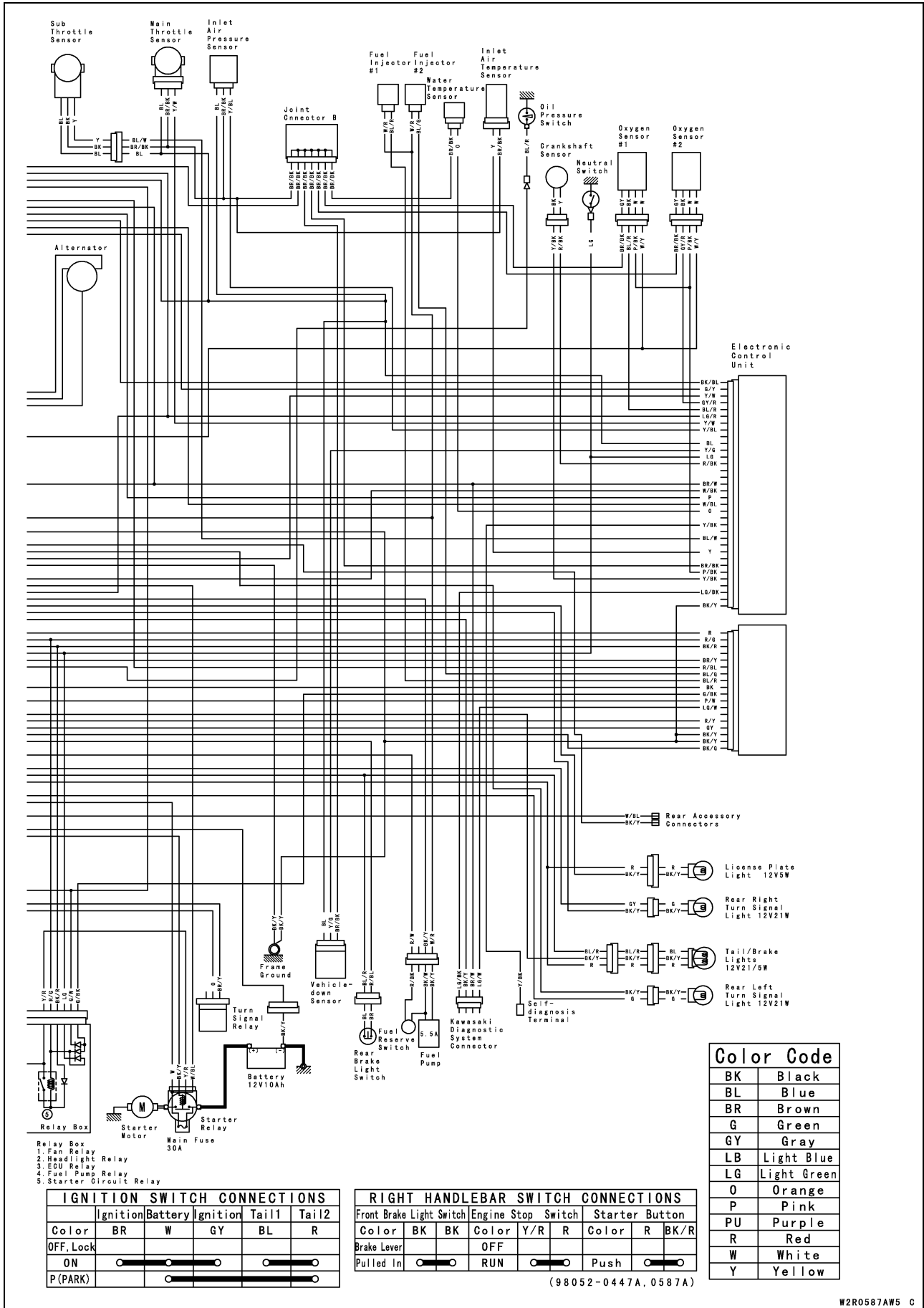

16-28 ELECTRICAL SYSTEM

Wiring Diagram (VN900C9 ~)

AU Model

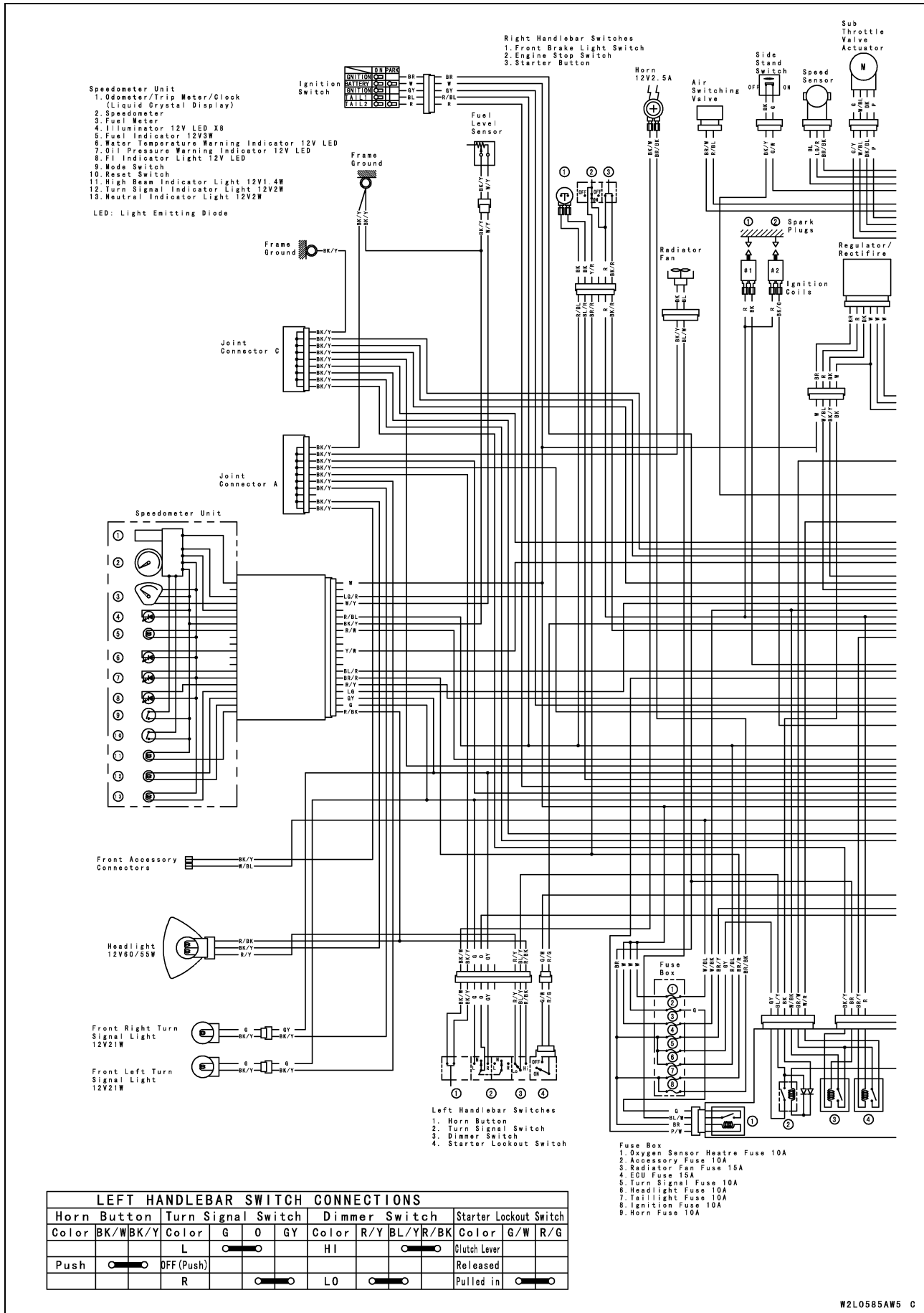

Wiring Diagram (VN900C9 ~)

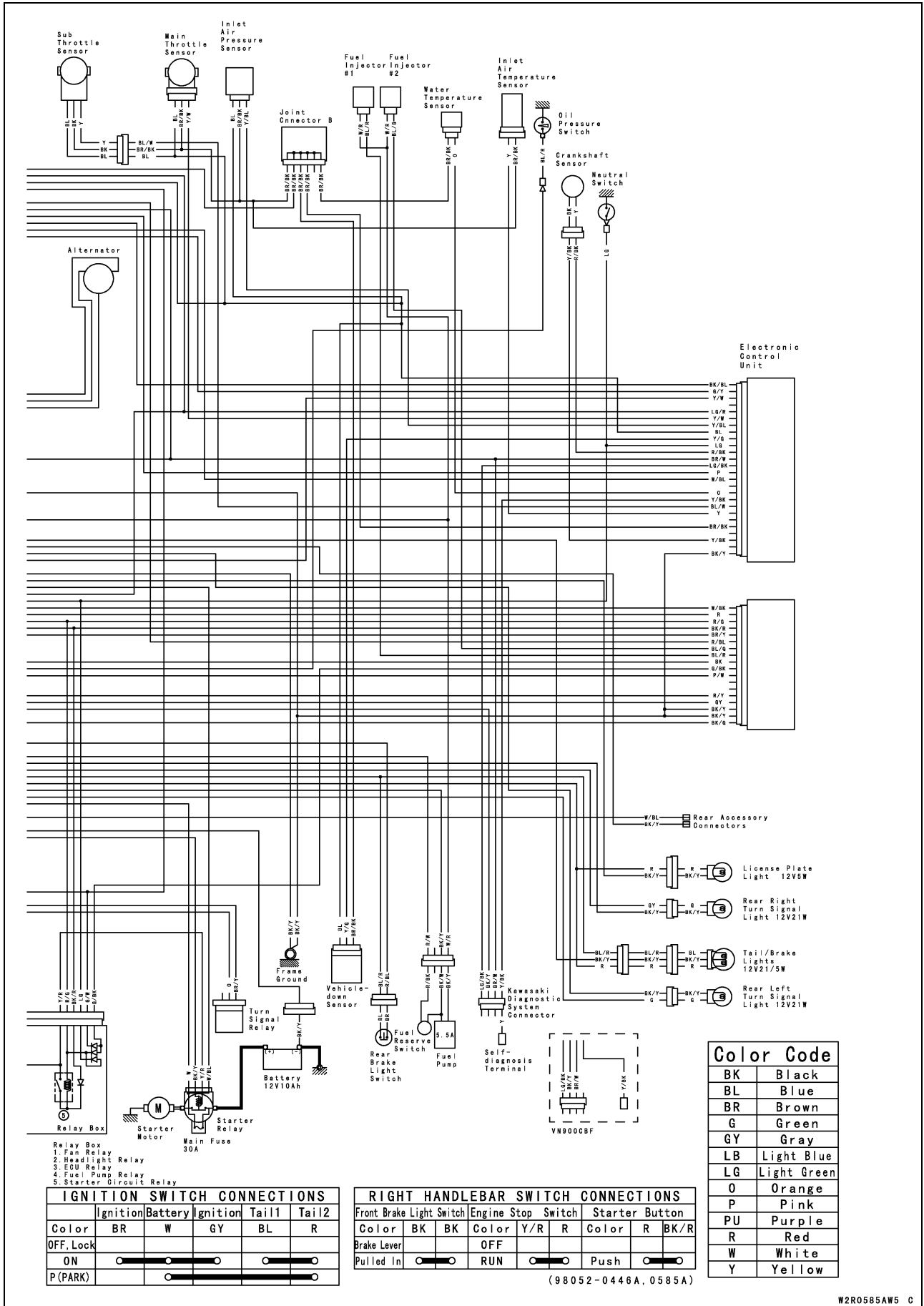

16-30 ELECTRICAL SYSTEM

Wiring Diagram (VN900C9 ~)

SEA-B1 (VN900C9 ~ CB) and TH Models

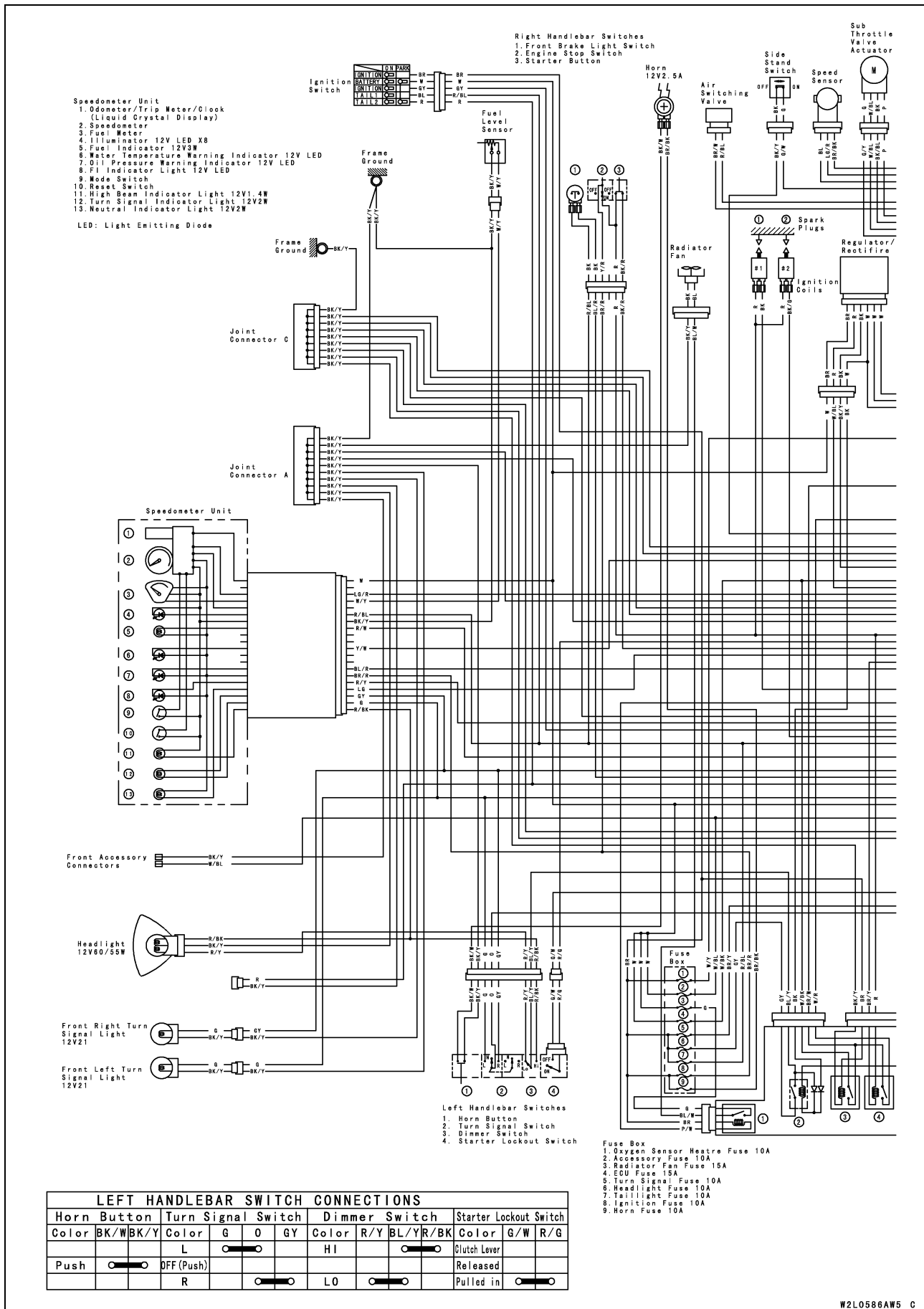

Wiring Diagram (VN900C9 ~)

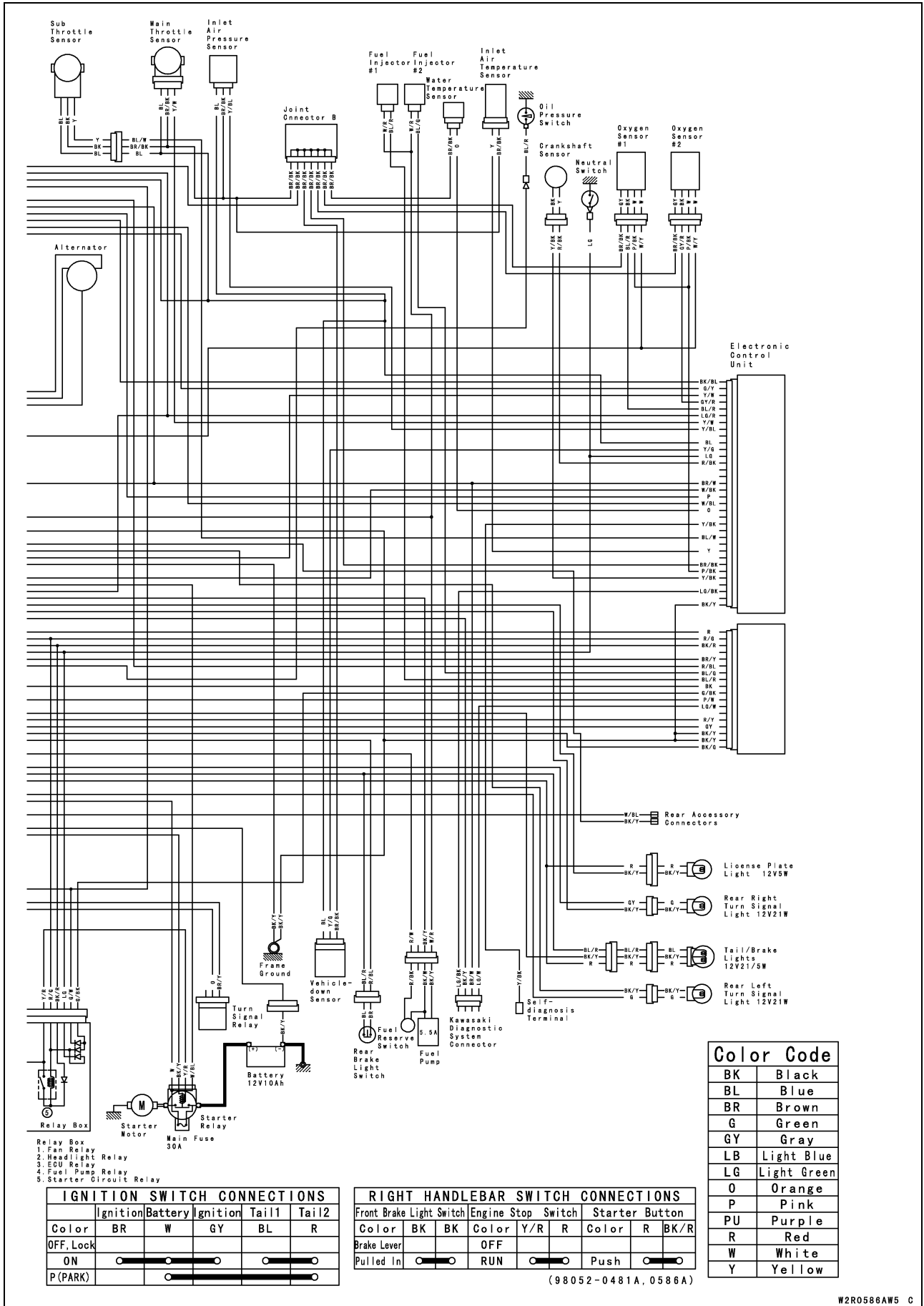

16-32 ELECTRICAL SYSTEM

Precautions

There are a number of important precautions that are musts when servicing electrical systems. Learn and observe all the rules below.

- Do not reverse the battery cable connections. This will burn out the diodes on the electrical parts.
- Always check battery condition before condemning other parts of an electrical system. A fully charged battery is a must for conducting accurate electrical system tests.
- The electrical parts should never be struck sharply, as with a hammer, or allowed to fall on a hard surface. Such a shock to the parts can damage them.
- To prevent damage to electrical parts, do not disconnect the battery cables or any other electrical connections when the ignition switch is on, or while the engine is running.
- Because of the large amount of current, never keep the starter button pushed when the starter motor will not turn over, or the current may burn out the starter motor windings.
- Do not use a meter illumination bulb rated for other than voltage or wattage specified in the wiring diagram, as the meter or gauge panel could be warped by excessive heat radiated from the bulb.
- Take care not to short the cables that are directly connected to the battery positive (+) terminal to the chassis ground.
- Troubles may involve one or in some cases all items. Never replace a defective part without determining what CAUSED the failure. If the failure was caused by some other item or items, they must be repaired or replaced, or the new replacement will soon fail again.
- Make sure all connectors in the circuit are clean and tight, and examine wires for signs of burning, fraying, etc. Poor wires and bad connections will affect electrical system operation.
- Measure coil and winding resistance when the part is cold (at room temperature).
- Color Codes:

| | | |
|----------------|-----------------|------------|
| BK: Black | G: Green | P: Pink |
| BL: Blue | GY: Gray | PU: Purple |
| BR: Brown | LB: Light Blue | R: Red |
| CH: Chocolate | LG: Light Green | W: White |
| DG: Dark Green | O: Orange | Y: Yellow |

Precautions

○Electrical Connectors
Connectors [A]

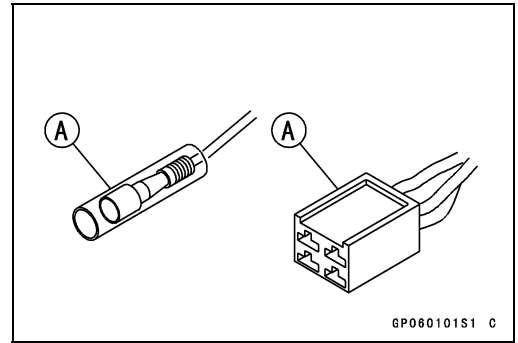

Connectors [B]

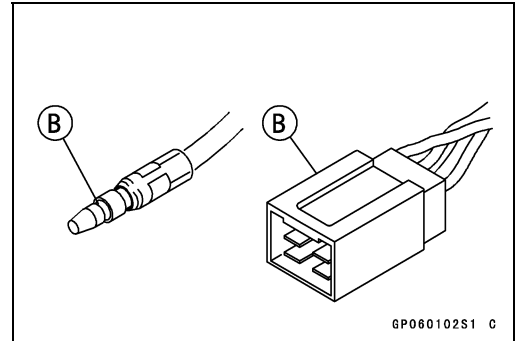

16-34 ELECTRICAL SYSTEM

Electrical Wiring

Wiring Inspection

- Visually inspect the wiring for signs of burning, fraying, etc.
- ★ If any wiring is poor, replace the damaged wiring.
- Pull each connector [A] apart and inspect it for corrosion, dirt, and damage.
- ★ If the connector is corroded or dirty, clean it carefully. If it is damaged, replace it.
- Check the wiring for continuity.
- Use the wiring diagram to find the ends of the lead which is suspected of being a problem.
- Connect a tester between the ends of the leads.
- ★ If the tester does not read 0 Ω , the lead is defective. Replace the lead or the wiring harness [B] if necessary.

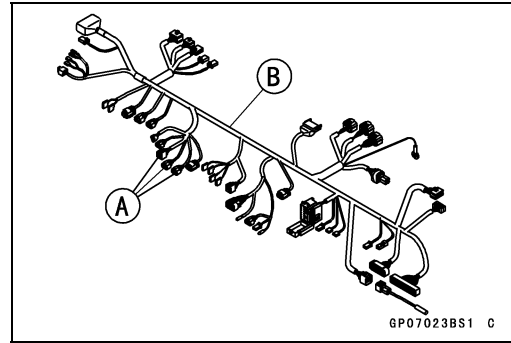

Battery

Battery Removal

- Remove:
 - Seat (see Seat Removal in the Frame chapter)
 - Tool Box (see Tool Box Removal in the Frame chapter)
- Disconnect the negative (-) cable [A].
- Slide out the positive (+) terminal cap [B] and then disconnect the positive (+) cable.

NOTICE

Be sure to disconnect the negative (-) cable first.

- Remove the battery.

Battery Installation

- Put the battery into the battery case.
- Apply a light coat of grease on the terminals to prevent corrosion.
- Install the positive (+) cable [A] first.
- Cover the positive (+) terminal with the cap [B].
- Install the negative (-) cable [C].

Battery Activation

Electrolyte Filling

- Make sure that the model name [A] of the electrolyte container matches the model name [B] of the battery. These names must be the same.

Battery Model Name

VN900C: YTX12-BS

NOTICE

Each battery comes with its own specific electrolyte container; using the wrong container may overfill the battery with incorrect electrolyte, which can shorten battery life and deteriorate battery performance. Be sure to use the electrolyte container with the same model name as the battery since the electrolyte volume and specific gravity vary with the battery type.

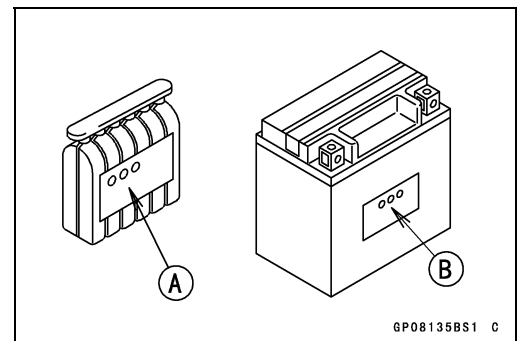
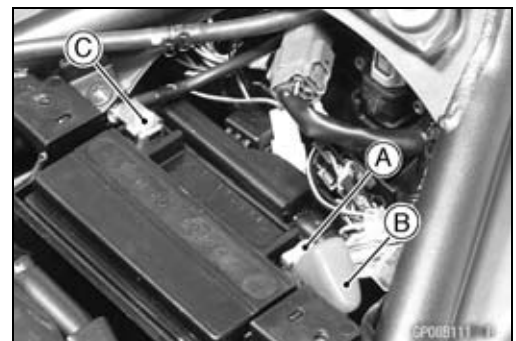
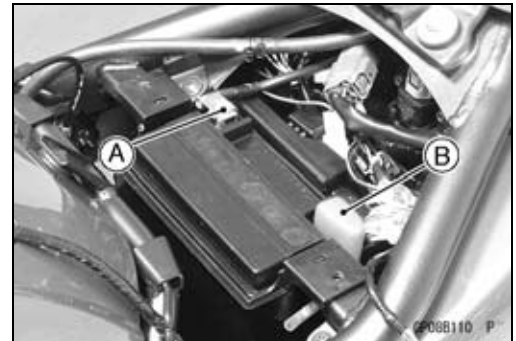

16-36 ELECTRICAL SYSTEM

Battery

NOTICE

Do not remove the aluminum sealing sheet [A] from the filler ports [B] until just prior to use. Be sure to use the dedicated electrolyte container for correct electrolyte volume.

⚠ DANGER

Sulfuric acid in battery electrolyte can cause severe burns. To prevent burns, wear protective clothing and safety glasses when handling electrolyte. If the electrolyte comes in contact with your skin or eyes, wash the area with liberal amounts of water and seek medical attention for more severe burns.

- Place the battery on a level surface.
- Check to see that the sealing sheet has no peeling, tears, or holes in it.
- Remove the sealing sheet.

NOTE

○The battery is vacuum sealed. If the sealing sheet has leaked air into the battery, it may require a longer initial charge.

- Remove the electrolyte container from the vinyl bag.
- Detach the strip of caps [A] from the container and set aside, these will be used later to seal the battery.

NOTE

○Do not pierce or otherwise open the sealed cells [B] of the electrolyte container. Do not attempt to separate individual cells.

- Place the electrolyte container upside down with the six sealed cells into the filler ports of the battery. Hold the container level, push down to break the seals of all six cells. You will see air bubbles rising into each cell as the ports fill.

NOTE

○Do not tilt the electrolyte container.

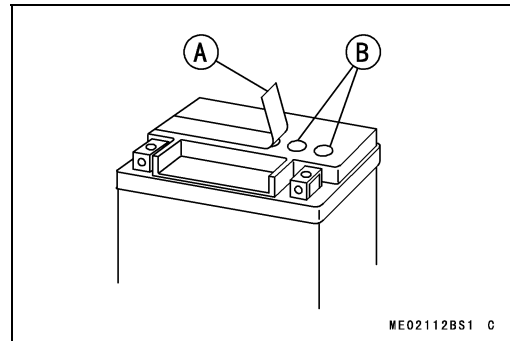

ME02112BS1 C

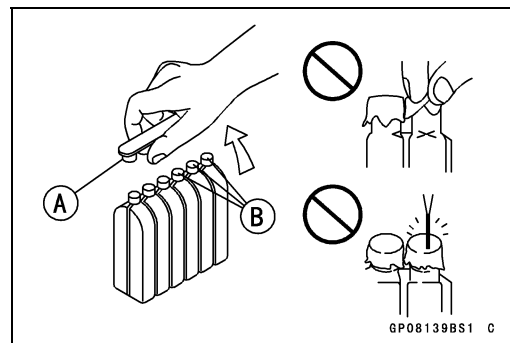

GP08139BS1 C

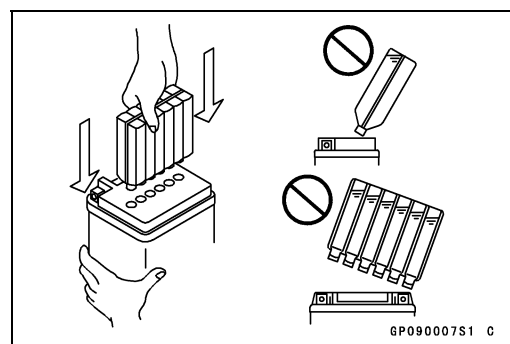

GP090007S1 C

Battery

- Check the electrolyte flow.
- ★ If no air bubbles [A] are coming up from the filler ports, or if the container cells have not emptied completely, tap the container [B] a few times.

NOTE

○ Be careful not to have the battery fall down.

- Keep the container in place. Don't remove the container from the battery, the battery requires all the electrolyte from the container for proper operation.

NOTICE

Removal of the container before it is completely empty can shorten the service life of the battery. Do not remove the container until it is completely empty.

- After filling, let the battery sit for 20 ~ 60 minutes with the electrolyte container kept in place, which is required for the electrolyte to fully permeate into the plates.
- Make sure that the container cells have emptied completely, and remove the container from the battery.
- Place the strip of caps [A] loosely over the filler ports, press down firmly with both hands to seat the strip of caps into the battery (don't pound or hammer). When properly installed, the strip of caps will be level with the top of the battery.

NOTICE

Once the strip of caps is installed onto the battery, never remove the caps, nor add water or electrolyte to the battery.

NOTE

○ Charging the battery immediately after filling can shorten service life.

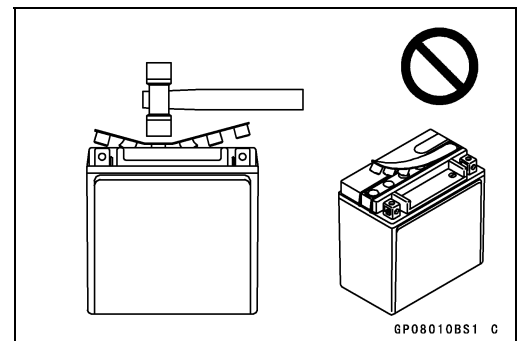
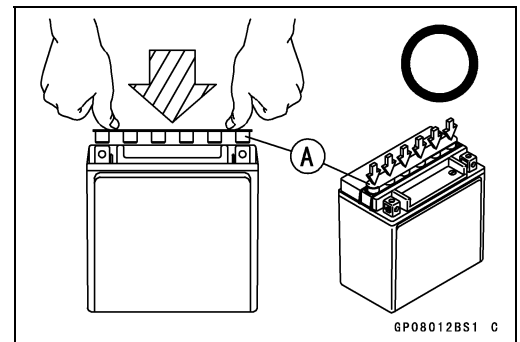
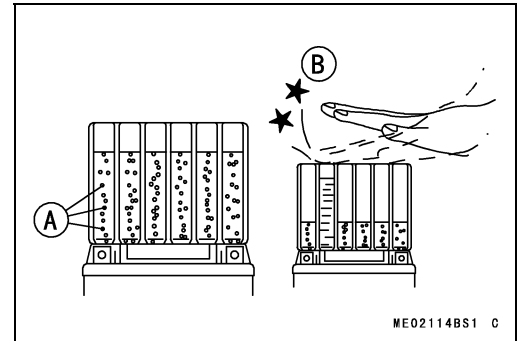

16-38 ELECTRICAL SYSTEM

Battery

Initial Charge

- Newly activated sealed batteries require an initial charge.

Standard Charge: 1.2 A × 5 ~ 10 hours

- ★ If using a recommended battery charger, follow the charger's instructions for newly activated sealed battery.

Kawasaki-recommended chargers:

Battery Mate 150-9

OptiMate PRO 4-S/PRO S/PRO2

Yuasa MB-2040/2060

Christie C10122S

- ★ If the above chargers are not available, use equivalent one.
- Let battery sit 30 minutes after initial charge, then check voltage using a voltmeter. (Voltage immediately after charging becomes temporarily high. For accurate measuring, let the battery sit for given time.)

NOTE

- *Charging rates will vary depending on how long the battery has been stored, temperature, and the type of charger used. If voltage is not at least 12.8 V, repeat charging cycle.*
- *To ensure maximum battery life and customer satisfaction, it is recommended the battery be load tested at three times its amp-hour rating for 15 seconds. Re-check voltage and if less than 12.8 V repeat the charging cycle and load test. If still below 12.8 V the battery is defective.*

Battery

Precautions

- 1) No need of topping-up
No topping-up is necessary in this battery until it ends its life under normal use. Forcibly prying off the seal cap to add water is very dangerous. Never do that.
- 2) Refreshing charge.
If an engine will not start, a horn sounds weak, or lamps are dim, it indicates the battery has been discharged. Give refresh charge for 5 to 10 hours with charge current shown in the specification (see Refreshing Charge).
When a fast charge is inevitably required, do it following precisely the maximum charge current and time conditions indicated on the battery.

NOTICE

This battery is designed to sustain no unusual deterioration if refresh-charged according to the method specified above. However, the battery's performance may be reduced noticeably if charged under conditions other than given above. Never remove the seal cap during refresh charge.

If by chance an excessive amount of gas is generated due to overcharging, the relief valve releases the gas to keep the battery normal.

- 3) When you do not use the motorcycle for months.
Give a refresh charge before you store the motorcycle and store it with the negative cable removed. Give a refresh charge **once a month** during storage.
- 4) Battery life.
If the battery will not start the engine even after several refresh charges, the battery has exceeded its useful life. Replace it (Provided, however, the vehicle's starting system has no problem).

DANGER

Batteries produce an explosive gas mixture of hydrogen and oxygen that can cause serious injury and burns if ignited. Keep the battery away from sparks and open flames during charging. When using a battery charger, connect the battery to the charger before turning on the charger. This procedure prevents sparks at the battery terminals which could ignite any battery gases. The electrolyte contains sulfuric acid. Be careful not to have it touch your skin or eyes. If touched, wash it off with liberal amount of water and seek medial attention for more severe burns.

Interchange

A sealed battery can fully display its performance only when combined with a proper vehicle electric system. Therefore, replace a sealed battery only on a motorcycle which was originally equipped with a sealed battery.

Be careful, if a sealed battery is installed on a motorcycle which had an ordinary battery as original equipment, the sealed battery's life will be shortened.

16-40 ELECTRICAL SYSTEM

Battery

Charging Condition Inspection

○ Battery charging condition can be checked by measuring battery terminal voltage with a digital voltmeter [A].

- Remove:
 - Seat (see Seat Removal in the Frame chapter)
 - Tool Box (see Tool Box Removal in the Frame chapter)
 - Battery Cable Cap (see Battery Removal)
- Disconnect the battery terminals.

NOTICE

Be sure to disconnect the negative (-) cable first.

- Measure the battery terminal voltage.

NOTE

○ Measure with a digital voltmeter which can be read one decimal place voltage.

- ★ If the reading is 12.8 V or more, no refresh charge is required, however, if the read is below the specified, refresh charge is required.

Battery Terminal Voltage

Standard: 12.8 V or more

Terminal Voltage (V) [A]

Battery Charge Rate (%) [B]

Good [C]

Refresh charge is required [D]

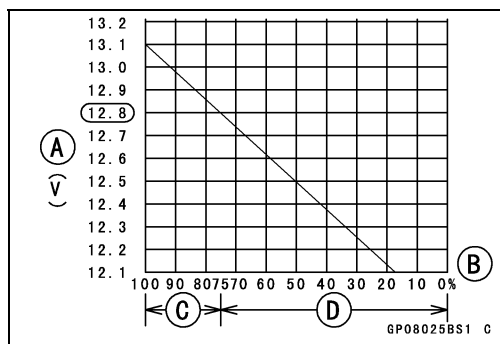
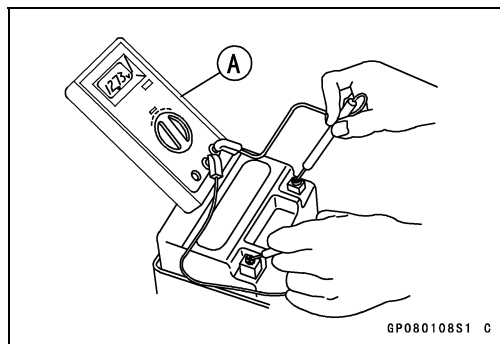

Refreshing Charge

- Remove the battery [A] (see Battery Removal).
- Do refresh charge by following method according to the battery terminal voltage.

WARNING

This battery is sealed type. Never remove sealing cap [B] even at charging. Never add water. Charge with current and time as stated below.

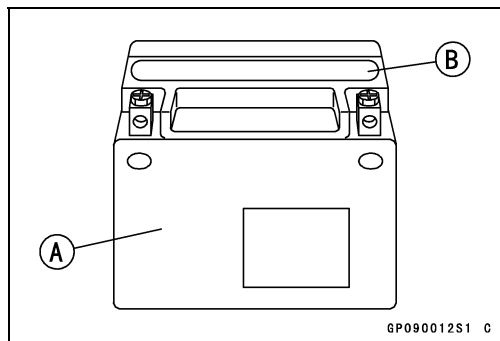

Battery

Terminal Voltage: 11.5 ~ less than 12.8 V
 Standard Charge 1.2 A × 5 ~ 10 h (see following chart)
 Quick Charge 5 A × 1 h

NOTICE

If possible, do not quick charge. If quick charge is done unavoidably, do standard charge later on.

Terminal Voltage: less than 11.5 V
 Charging Method 1.2 A × 20 h

NOTE

○ Increase the charging voltage to a maximum voltage of 25 V if the battery will not accept current initially. Charge for no more than 5 minutes at the increased voltage then check if the battery is drawing current. If the battery will accept current decrease the voltage and charge by the standard charging method described on the battery case. If the battery will not accept current after 5 minutes, replace the battery.

Battery [A]
 Battery Charger [B]
 Standard Value [C]
 Current starts to flow [D]

- Determine the battery condition after refresh charge.
- Determine the condition of the battery left for 30 minutes after completion of the charge by measuring the terminal voltage according to the table below.

| Criteria | Judgement |
|--------------------------|--------------------------------|
| 12.8 V or higher | Good |
| 12.0 ~ lower than 12.8 V | Charge insufficient → Recharge |
| lower than 12.0 V | Unserviceable → Replace |

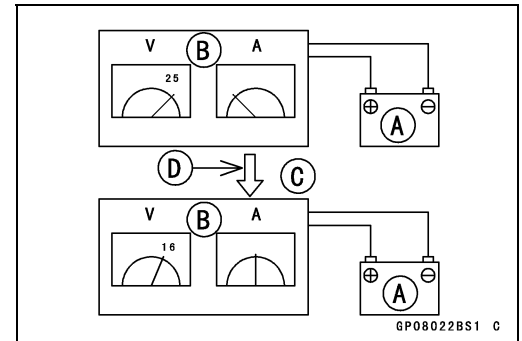
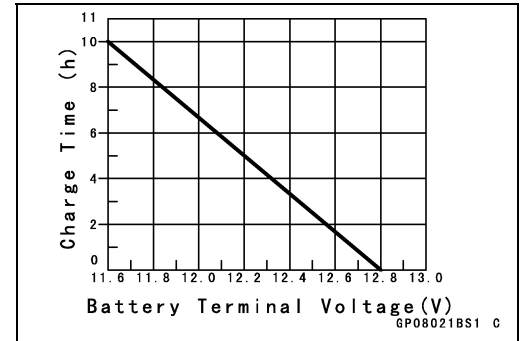

16-42 ELECTRICAL SYSTEM

Charging System

Alternator Outer Cover Removal

- Remove:
 - Bolts [A]
 - Alternator Outer Cover [B]

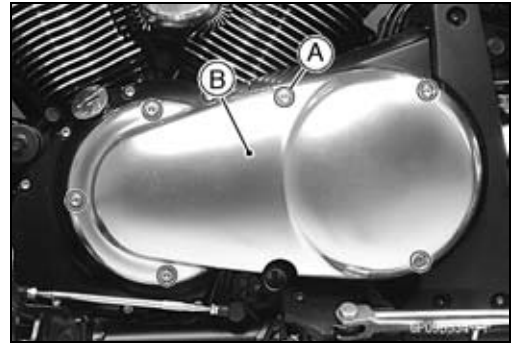

Alternator Outer Cover Installation

- For other than US, CA and CAL models (VN900C9 ~), be sure the dampers [A] and trim [B] are in position.

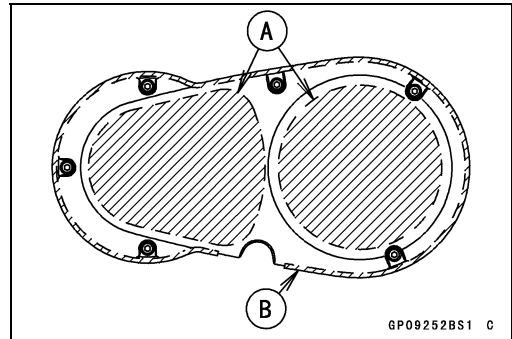

- Install the alternator outer cover.
- Tighten:
 - Torque - Alternator Outer Cover Bolts: 9.8 N·m (1.0 kgf·m, 87 in·lb)

Alternator Cover Removal

- Drain the engine oil (see Engine Oil Change in the Periodic Maintenance chapter).
- Remove:
 - Left Footpeg (see Footpeg Removal/Installation in the Frame chapter)
 - Alternator Outer Cover (see Alternator Outer Cover Removal)
 - Engine Pulley Cover (see Engine Pulley Cover Removal in the Final Drive chapter)
 - Crankshaft Sensor Lead Connector [A]
- Remove:
 - Seat (see Seat Removal in the Frame chapter)
 - Left Side Cover (see Left Side Cover Removal in the Frame chapter)
 - Tool Box (see Tool Box Removal in the Frame chapter)
 - Plug [A] and Bolt
 - Ignition Switch [B]
 - Alternator Lead Connector [C]

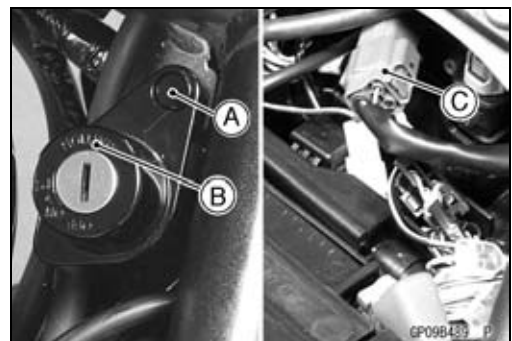

Charging System

- Remove:
 - Bolts [A]
 - Alternator Cover [B]

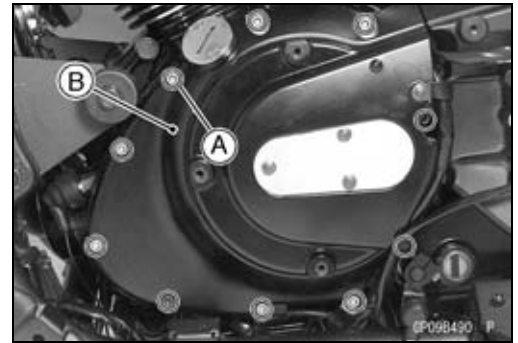

Alternator Cover Installation

- Replace the alternator cover gasket with a new one.
- Check to see that the dowel pins [A] are in place.
- Tighten:
 - Torque - Alternator Cover Bolts: 9.8 N·m (1.0 kgf·m, 87 in·lb)**
- Install the removed parts (see appropriate chapters).

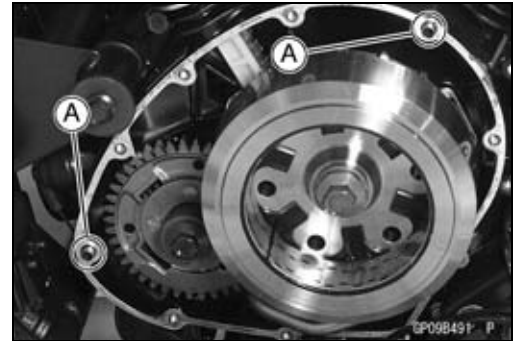

Stator Coil Removal

- Remove:
 - Alternator Cover (see Alternator Cover Removal)
 - Bolts [A]
 - Alternator Lead Holder Plate [B]
 - Bolts [C]
 - Crankshaft Sensor [D]
 - Crankshaft Sensor and Alternator Lead Grommets [E]
 - Stator Coil Bolts [F]
- Remove the stator coil [G] from the alternator cover.

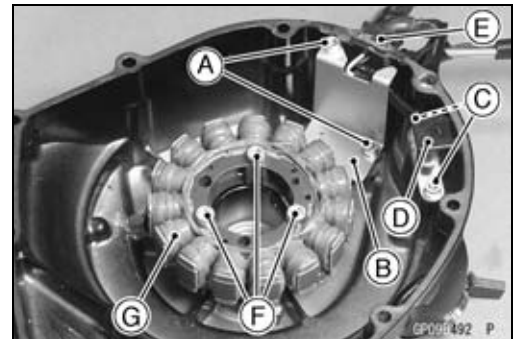

Stator Coil Installation

- Apply a non-permanent locking agent to the threads of the stator coil bolts.
- Tighten:
 - Torque - Stator Coil Bolts: 12 N·m (1.2 kgf·m, 106 in·lb)**
- Apply silicone sealant to the circumference of the alternator lead and crankshaft sensor lead grommets, and fit the grommets into the notch of the cover securely.
 - Sealant - Liquid Gasket, TB1211F: 92104-0004**
- First install the alternator lead grommet and then crankshaft sensor lead grommet.
- Secure the alternator lead and crankshaft sensor lead with holder plate, and tighten the bolts.
 - Torque - Alternator Lead Holder Plate Bolts: 5.9 N·m (0.60 kgf·m, 52 in·lb)**
- Install the alternator cover (see Alternator Cover Installation).

16-44 ELECTRICAL SYSTEM

Charging System

Alternator Rotor Removal

- Remove the alternator cover (see Alternator Cover Removal).
- Wipe oil off the outer circumference of the rotor.
- Hold the alternator rotor steady with the rotor holder [A], and remove the rotor bolt [B] and washer.

Special Tools - Grip [C]: 57001-1591

Rotor Holder: 57001-1674

- The rotor holder is prevented from turning by using the suitable M10 bolt [D] and footpeg bracket bolt hole.

- Using the rotor puller [A], remove the alternator rotor from the crankshaft.

Special Tool - Rotor Puller, M16/M18/M20/M22 × 1.5: 57001-1216

NOTE

- Screw in the puller while tapping the head [B] of the puller with a hammer.

NOTICE

Do not attempt to strike the alternator rotor itself. Striking the rotor can cause the magnets to lose their magnetism.

Alternator Rotor Installation

- Using a cleaning fluid, clean off any oil or dirt on the following portions and dry them with a clean cloth.
 - Crankshaft Tapered Portion [A]
 - Alternator Rotor Tapered Portion [B]
- Fit the woodruff key securely in the slot [C] in the crankshaft before installing the alternator rotor.

- Align the left balancer mark [A] with the left crankcase projection [B].

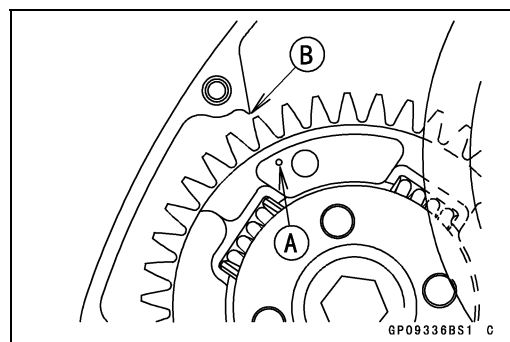
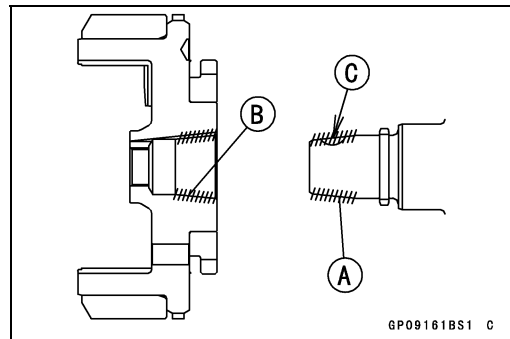
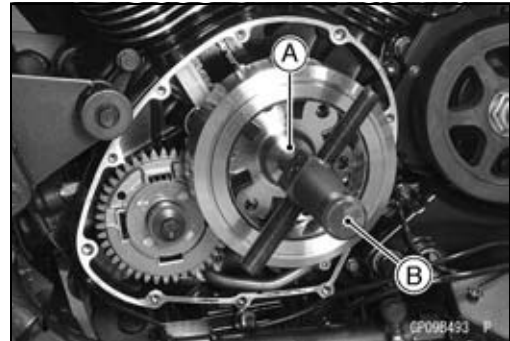
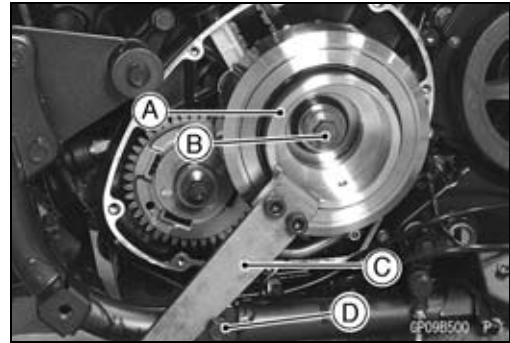

Charging System

- When installing the alternator rotor, align the rotor mark [A] with the left crankcase projection [B].
- Apply molybdenum disulfide oil solution to the threads and seating surface of the alternator rotor bolt.

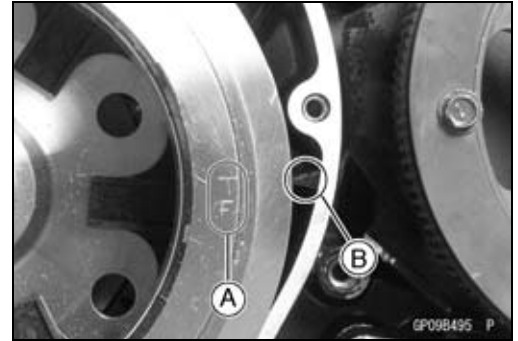

- Install the washer.

NOTE

○ Confirm the alternator rotor fit or not to the crankshaft before tightening it with specified torque.

- Install the rotor bolt and tighten it with 69 N·m (7.0 kgf·m, 51 ft·lb) of torque.
- Remove the rotor bolt and washer.
- Check the tightening torque with M20 bolt [A] in the flywheel puller assembly.

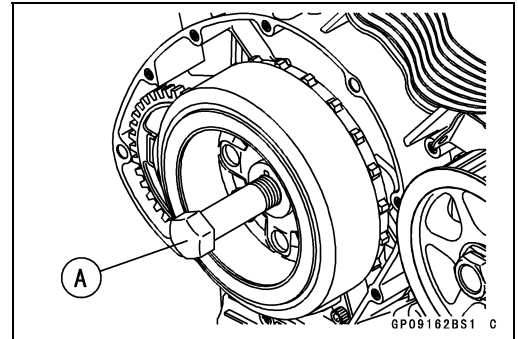

Special Tool - Flywheel Puller Assembly, M38 × 1.5/M35 × 1.5: 57001-1405

- ★ If the rotor is not pulled out with 20 N·m (2.0 kgf·m, 15 ft·lb) of drawing torque, it is installed correctly.
- ★ If the rotor is pulled out with under 20 N·m (2.0 kgf·m, 15 ft·lb) of drawing torque, clean off any oil dirt or flaw of the crankshaft and rotor tapered portion, and dry them with a clean cloth. Then, confirm that it is not pulled out with above torque.

- Tighten the alternator rotor bolt [A] while holding the alternator rotor steady with the rotor holder [B].

Special Tools - Grip [C]: 57001-1591

Rotor Holder: 57001-1674

- The rotor holder is prevented from turning by using the suitable M10 bolt [D] and footpeg bracket bolt hole.

Torque - Alternator Rotor Bolt: 160 N·m (16.3 kgf·m, 118 ft·lb)

- Install the alternator cover (see Alternator Cover Installation).

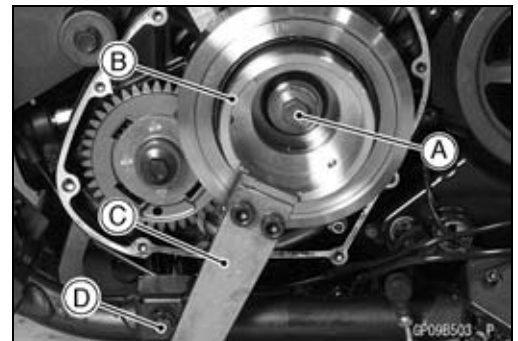

Alternator Inspection

There are three types of alternator failures: short, open (lead burned out), or loss in rotor magnetism. A short or open in one of the stator coil lead will result in either a low output, or no output at all. A loss in rotor magnetism, which may be caused by dropping or hitting the alternator, by leaving it near an electromagnetic field, or just by aging, will result in low output.

16-46 ELECTRICAL SYSTEM

Charging System

- To check the alternator output voltage, do the following procedures.
- Remove the regulator/rectifier and disconnect the connector [A].
- Connect a tester to the connector as shown in the figure.
- Start the engine.
- Run it at 4 000 rpm of the engine speed.
- Note the voltage readings.

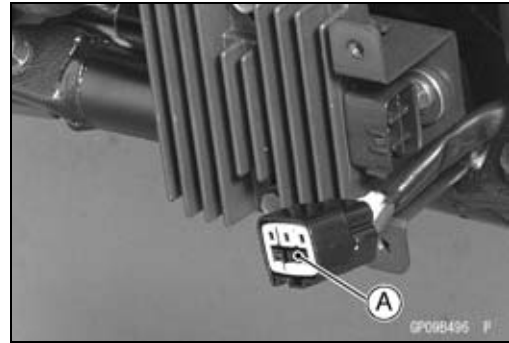

Alternator Output Voltage

| Connections | | Reading at 4 000 rpm |
|----------------|--------------------|----------------------|
| Tester (+) to | Tester (-) to | |
| One White lead | Another White lead | AC 54 V or more |

- ★ If the output voltage shows the value in the table, the alternator operates properly and the regulator/rectifier is damaged. A much lower reading than the value in the table indicates that the alternator is defective.
- Repeat the test for the other white leads.

Tester [A]

- Check the stator coil resistance as follows.
- Turn off the ignition switch.
- Connect the tester [A] to the connector as shown in the table.
- Note the resistance readings.

Stator Coil Resistance

| Connections | | Reading |
|----------------|--------------------|---------------|
| Tester (+) to | Tester (-) to | |
| One White lead | Another White lead | 0.11 ~ 0.17 Ω |

- ★ If there is more resistance than shown in the table, or no tester reading (infinity), the stator has an open lead and must be replaced. Much less than this resistance means the stator is shorted, and must be replaced.
- Using the highest resistance range of the tester, measure the resistance between each of the white leads and chassis ground.
- ★ Any tester reading less than infinity (∞) indicates a short, necessitating stator replacement.
- ★ If the stator coil has normal resistance, but the voltage check showed the alternator to be defective, then the rotor magnets have probably weakened, and the rotor must be replaced.
- Repeat the test for the other white leads.

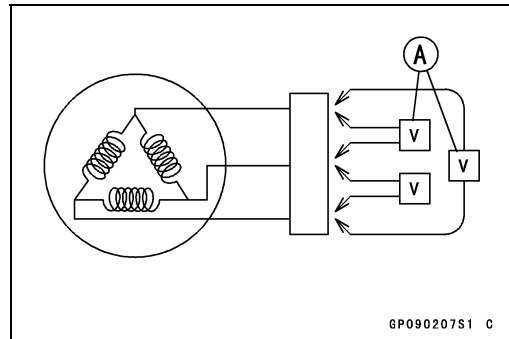

GP090207S1 C

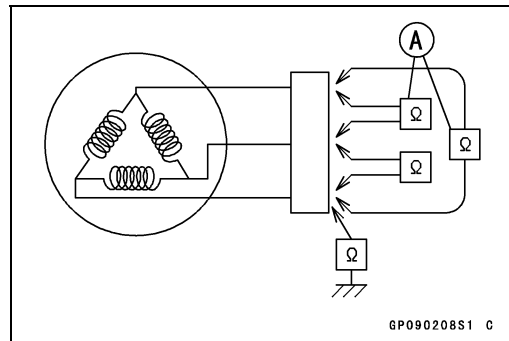

GP090208S1 C

Charging System

Regulator/Rectifier Removal

- Remove:
 - Bolts [A]
 - Regulator/Rectifier Cover [B]

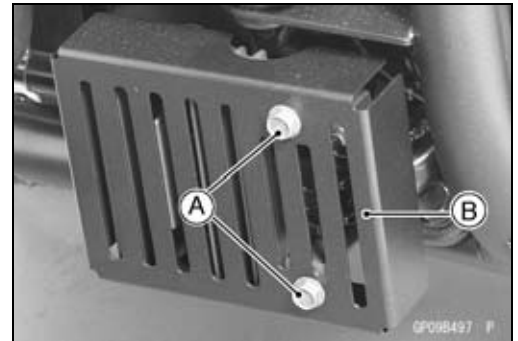

- Remove:
 - Bolts [A]
 - Regulator/Rectifier [B]
 - Connector [C] (Disconnect)

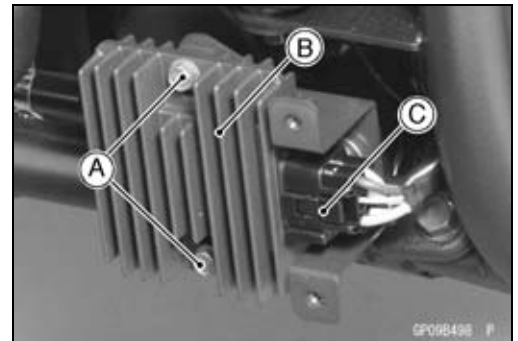

Regulator/Rectifier Inspection

Rectifier Circuit Check

- Remove the regulator/rectifier (see Regulator/Rectifier Removal).
- Check conductivity of the following pair of terminals.

Rectifier Circuit Inspection

| | | | |
|-------------------|--------|--------|-------|
| Tester connection | R-W1, | R-W2, | R-W3 |
| | BK-W1, | BK-W2, | BK-W3 |

- ★ The resistance should be low in one direction and more than ten times as much in the other direction. If any two leads are low or high in both directions, the rectifier is defective and the regulator/rectifier must be replaced.

NOTE

- The actual meter reading varies with the meter used and the individual rectifier, but, generally speaking the lower reading should be from zero to one half the scale.

Regulator Circuit Check

To test the regulator out of circuit, use three 12 V batteries and a test light (12 V 3 ~ 6 W bulb in a socket with leads).

NOTICE

The test light works as an indicator and also a current limiter to protect the regulator/rectifier from excessive current. Do not use an ammeter instead of a test light.

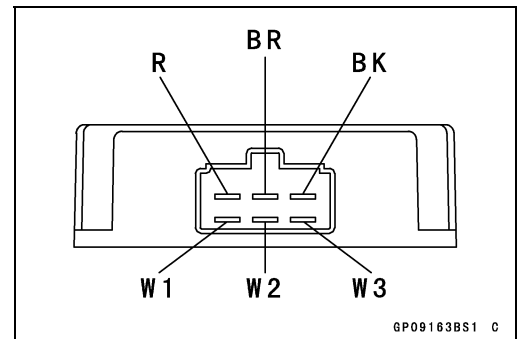

16-48 ELECTRICAL SYSTEM

Charging System

- Do the 1st step regulator circuit test.
- Connect the test light and the 12 V battery to the regulator/rectifier as shown in the figure.
- Check the W1, W2 and W3 terminal respectively.
- ★ If the test light turns on, the regulator/rectifier is defective. Replace it.
- ★ If the test light does not turn on, continue the test.

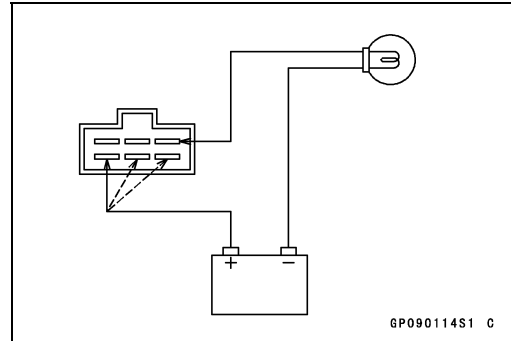

- Do the 2nd step regulator circuit test.
- Connect the test light and the 12 V battery in the same manner as specified in the "1st step regulator circuit test".
- Apply 12 V to the BR terminal.
- Check the W1, W2 and W3 terminal respectively.
- ★ If the test light turns on, the regulator/rectifier is defective. Replace it.
- ★ If the test light does not turn on, continue the test.

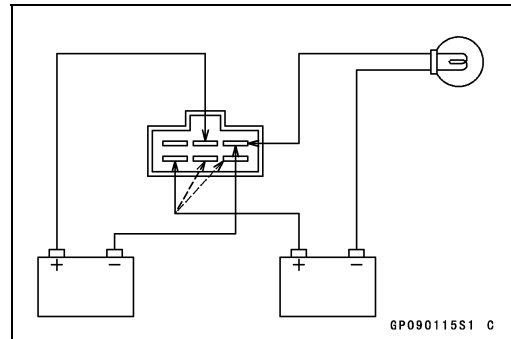

- Do the 3rd step regulator circuit test.
- Connect the test light and the 12 V battery in the same manner as specified in the "1st step regulator circuit test".
- Momentarily apply 24 V to the BR terminal by adding a 12 V battery.
- Check the W1, W2, and W3 terminals respectively.

NOTICE

Do not apply more than 24 V to the regulator/rectifier and do not leave the 24 V applied for more than a few seconds, or the unit will be damaged.

- ★ If the test light did not light when the 24 V was applied momentarily to the BR terminal, the regulator/rectifier is defective. Replace it.
- ★ If the regulator/rectifier passes all of the tests described, it may still be defective. If the charging system still does not work properly after checking all of the components and the battery, test the regulator/rectifier by replacing it with a known good unit.

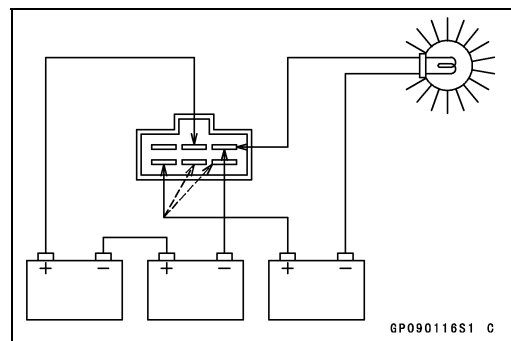

Charging System

Charging Voltage Inspection

- Check the battery condition (see Charging Condition Inspection).
- Warm up the engine to obtain actual alternator operating conditions.
- Remove:
 - Seat (see Seat Removal in the Frame chapter)
 - Tool Box (see Tool Box Removal in the Frame chapter)
- Check that the ignition switch is turned off, and connect a tester [A] to the battery terminals [B].
- Start the engine, and note the voltage readings at various engine speeds with the headlight turned on and then turned off (To turn off the headlight, disconnect the headlight connector on the headlight unit.). The readings should show nearly battery voltage when the engine speed is low, and, as the engine speed rises, the readings should also rise. But they must be kept under the specified voltage.

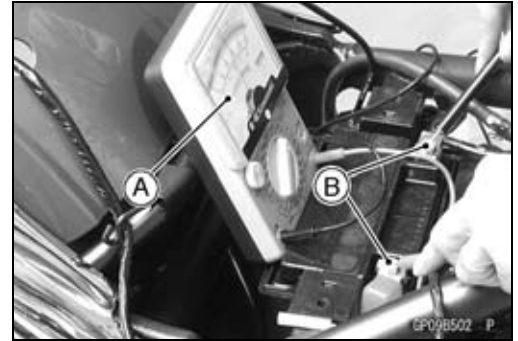

Charging Voltage

| Connections | | Reading |
|---------------|---------------|------------------|
| Tester (+) to | Tester (-) to | |
| Battery (+) | Battery (-) | DC 14.2 ~ 15.2 V |

- Turn off the ignition switch to stop the engine, and disconnect the tester.
- ★ If the charging voltage is kept between the values given in the table, the charging system is considered to be working normally.
- ★ If the charging voltage is much higher than the values specified in the table, the regulator/rectifier is defective or the regulator/rectifier leads are loose or open.
- ★ If the charging voltage does not rise as the engine speed increases, then the regulator/rectifier is defective or the alternator output is insufficient for the loads. Check the alternator and regulator/rectifier to determine which part is defective.

16-50 ELECTRICAL SYSTEM

Charging System

Charging System Circuit (VN900C7 ~ C8)

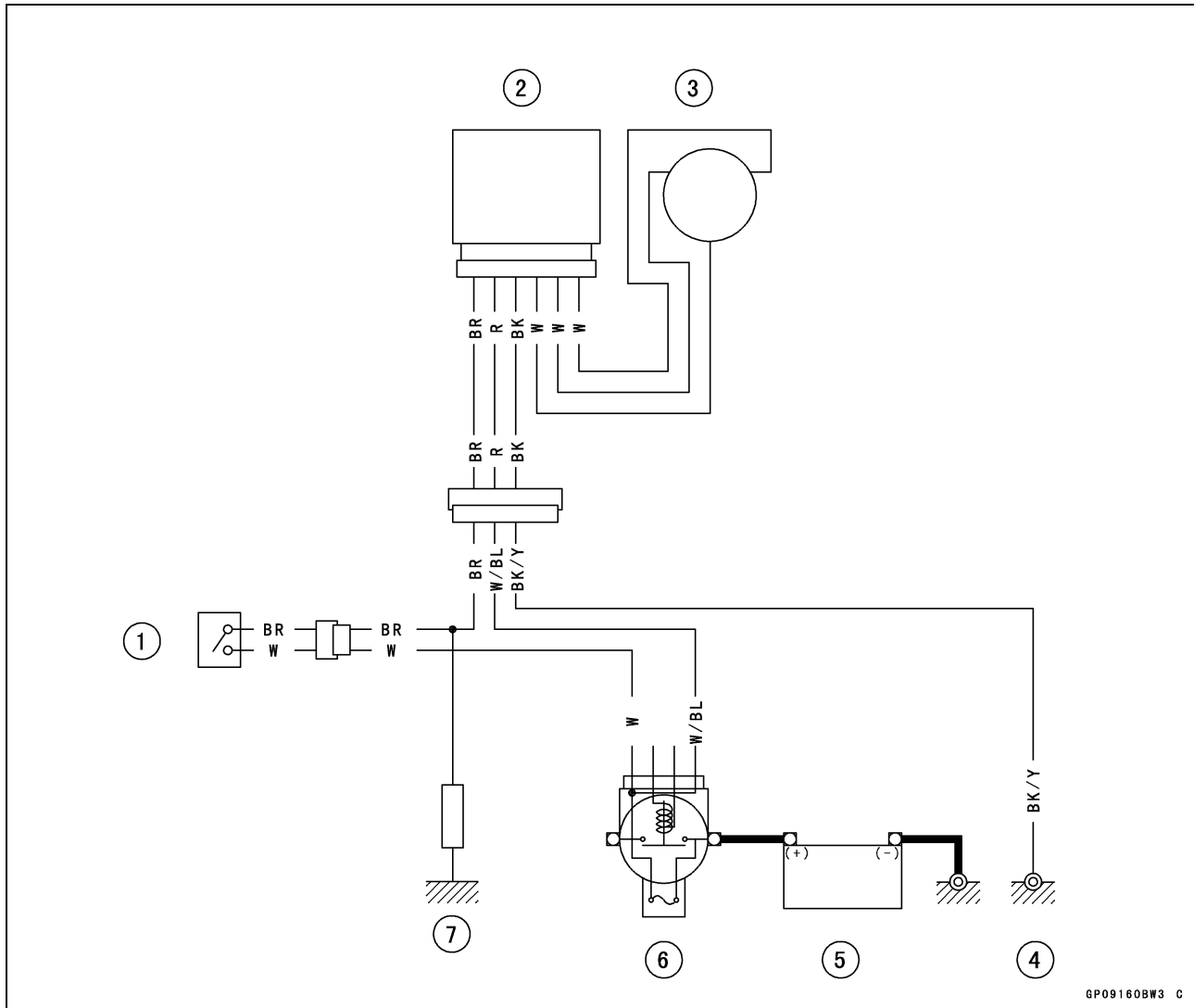

GP091608W3 C

1. Ignition Switch
2. Regulator/Rectifier
3. Alternator
4. Frame Ground
5. Battery
6. Main Fuse 30 A
7. Load

Charging System

Charging System Circuit (VN900C9 ~)

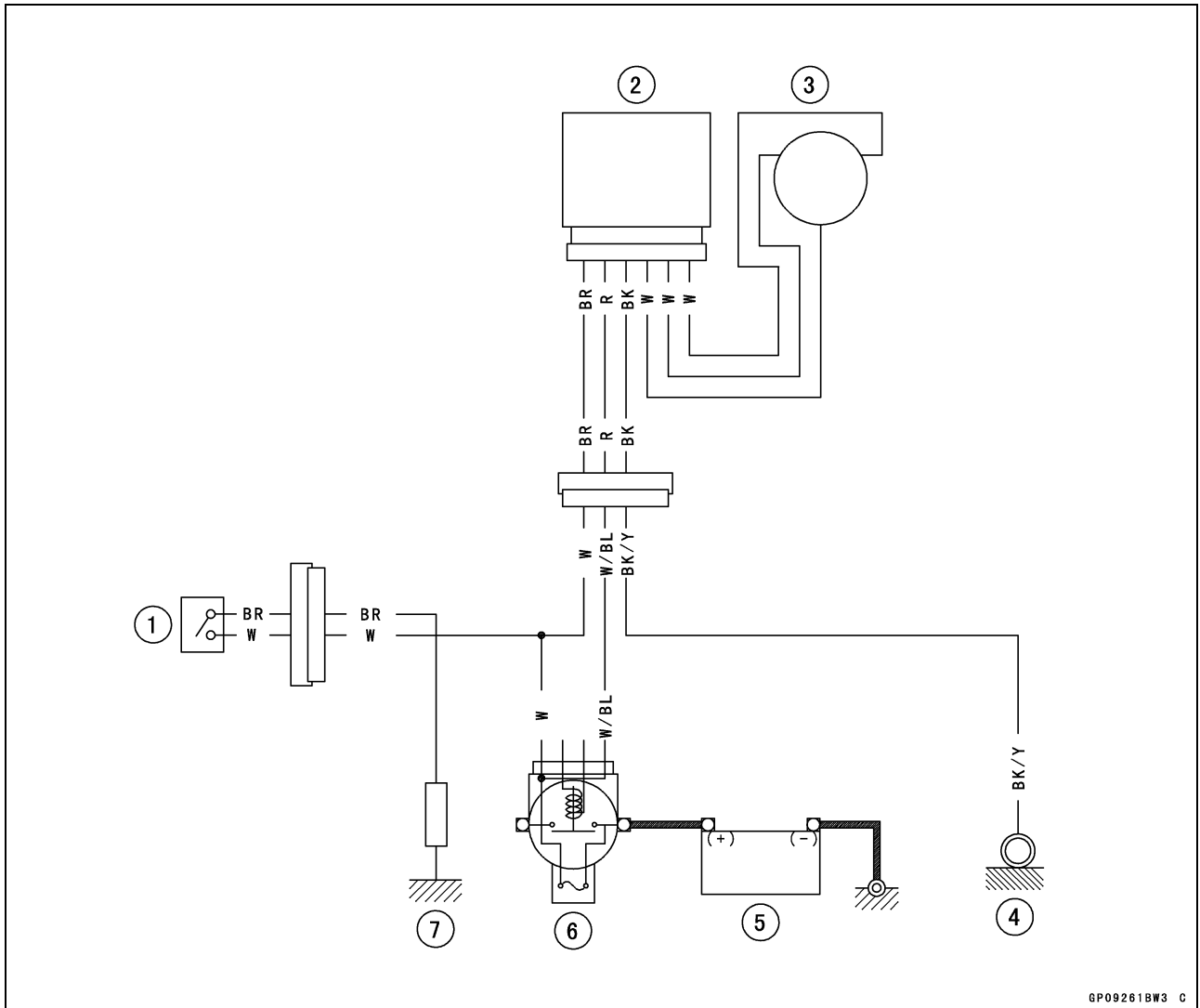

1. Ignition Switch
2. Regulator/Rectifier
3. Alternator
4. Frame Ground
5. Battery
6. Main Fuse 30 A
7. Load

16-52 ELECTRICAL SYSTEM

Ignition System

⚠ WARNING

The ignition system produces extremely high voltage. Do not touch the spark plug, ignition coil or ignition coil lead while the engine is running, or you could receive a severe electrical shock.

NOTICE

Do not disconnect the battery cables or any other electrical connections when the ignition switch is on, or while the engine is running. This is to prevent IC igniter damage in the ECU.

Do not install the battery backwards. The negative side is grounded. This is to prevent damage to the IC igniter in the ECU and the diodes.

Ignition Coil Removal

- Remove:
 - Screw [A]
 - Ignition Coil Cover [B]

- Remove:
 - Spark Plug Caps
 - Fuel Pump Connector [A]
 - Ignition Coil Bracket Bolts [B]
 - Primary Leads [C]
 - Ignition Coil Mounting Nuts [D]
 - Ignition Coils [E]

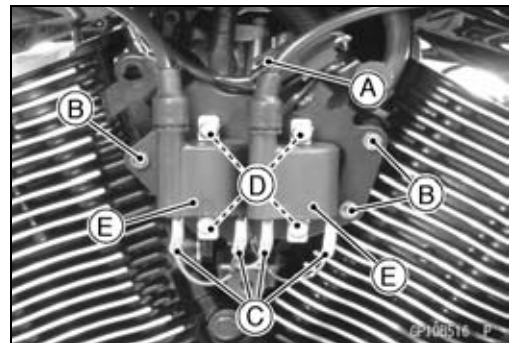
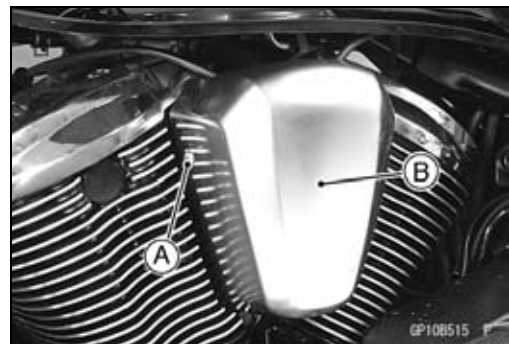

Ignition System

Ignition Coil Installation

- Installation is the reverse of removal.
- Connect the primary leads to the ignition coil terminals and run the secondary cables according to the Cable, Wire, and Hose Routing section in the Appendix chapter.
 - Front Ignition Coil [A]
 - Rear Ignition Coil [B]
 - Dampers [C]
 - Bracket [D]
- Tighten:
 - Torque - Ignition Coil Mounting Nuts: 6.9 N·m (0.70 kgf·m, 61 in·lb)**
 - Ignition Coil Bracket Bolts: 9.8 N·m (1.0 kgf·m, 87 in·lb)**

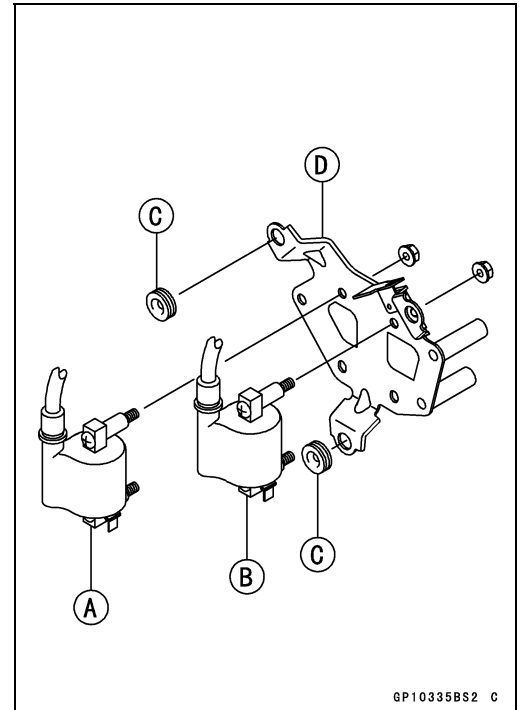

Ignition Coil Inspection

- Remove the ignition coils (see Ignition Coil Removal).
- Measure the arcing distance with a commercially available coil tester [A] to check the condition of the ignition coil [B].
- Connect the ignition coil (with the spark plug cap left attached at the end of the spark plug terminal) to the tester in the manner prescribed by the manufacturer and measure the arcing distance.

3 Needle Arcing Distance

Standard: 6 mm (0.24 in.) or more

⚠ WARNING

To avoid extremely high voltage shocks, do not touch the coil body or leads.

- ★ If the distance reading is less than the specified value, the ignition coil or spark plug caps are defective.
- To determine which part is defective, measure the arcing distance again with the spark plug caps removed from the ignition coil. Remove the caps by turning them counter-clockwise.
- ★ If the arcing distance is subnormal as before, the trouble is with the ignition coil itself. If the arcing distance is now normal, the trouble is with the spark plug cap.
- ★ If the coil tester is not available, the coil can be checked for a broken or badly shorted winding with a digital meter.

NOTE

- *The digital meter cannot detect layer shorts and shorts resulting from insulation breakdown under high voltage.*

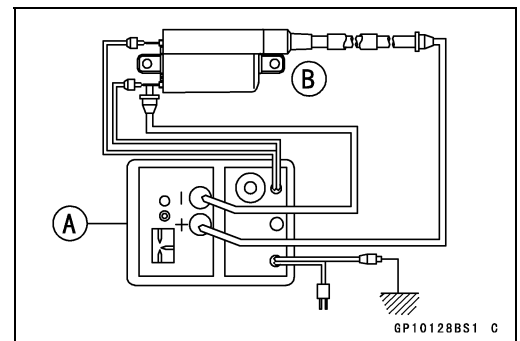

16-54 ELECTRICAL SYSTEM

Ignition System

- Measure the primary winding resistance as follows.
 - Connect the digital meter between the coil terminals.
 - Measure the secondary winding resistance as follows.
 - Remove the plug caps by turning them counterclockwise.
 - Connect the meter between the spark plug high-tension cables.
- Measure primary winding resistance [A].
 Measure secondary winding resistance [B].
 Ignition Coil [C]

Ignition Coil Winding Resistance

- Primary Windings:** 1.9 ~ 2.9 Ω
- Secondary Windings:** 10.6 ~ 15.8 kΩ

- ★ If the meter does not read as specified, replace the coil.
- To install the plug cap, turn it clockwise.

Ignition Coil Primary Peak Voltage Inspection

NOTE

○ Be sure the battery is fully charged.

- Remove the fuel tank (see Fuel Tank Removal in the Fuel System (DFI) chapter).
- Remove all the spark plug caps but do not remove the spark plugs.
- Install new spark plugs into all the spark plug caps, and ground them onto the engine.
- Install the peak voltage adapter [A] into a tester [B].

Special Tool - Peak Voltage Adapter: 57001-1415
Type: KEK-54-9-B

- Connect the adapter between the ignition coil primary lead terminal and the engine ground with the primary lead left connected.
- Insert the adapter probe into the terminal of the primary lead [C].
 ECU [D]
 Battery [E]
 Ignition Coil [F]
 New Spark Plug [G]

Primary Lead Connections

| | Adapter (R, +) | | Adapter (BK, -) |
|-----------------------------|----------------|---|-----------------|
| Front Ignition Coil: | BK | ↔ | R |
| Rear Ignition Coil: | BK/G | ↔ | R |

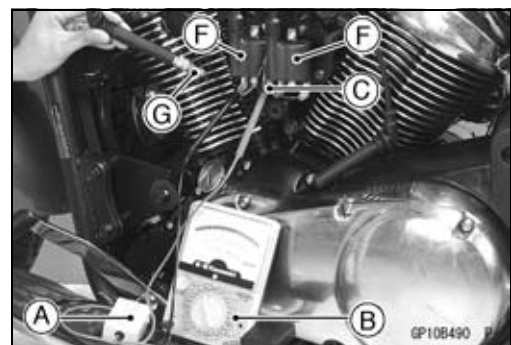
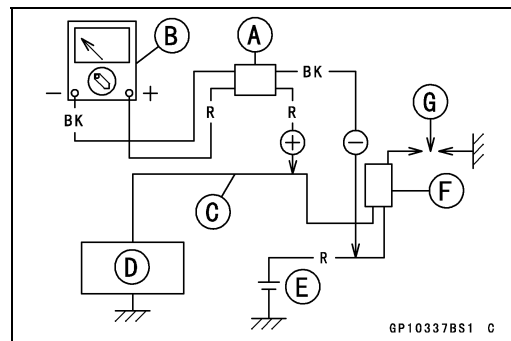
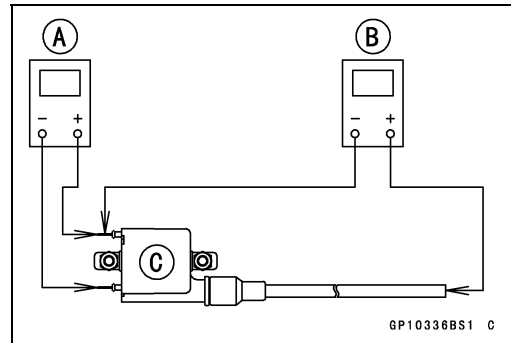

Ignition System

⚠ WARNING

To avoid extremely high voltage shocks, do not touch the spark plugs or tester connections.

- Turn the ignition switch and the engine stop switch ON.
- Pushing the starter button, turn the engine 4 ~ 5 seconds with the transmission in neutral to measure the primary peak voltage.
- Repeat the measurements 5 or more times for one ignition coil.

Ignition Coil Primary Peak Voltage

Standard: 184 V or more

- Repeat the test for the other ignition coil.
- ★ If the reading is less than the specified value, check the following.
 - Ignition Coils (see Ignition Coil Inspection)
 - Crankshaft Sensor (see Crankshaft Sensor Inspection)
- ★ If the ignition coils and crankshaft sensors are normal, check the ECU (see ECU Power Supply Inspection in the Fuel System (DFI) chapter).

Spark Plug Removal

- Refer to the Spark Plug Replacement in the Periodic Maintenance chapter.

Spark Plug Installation

- Refer to the Spark Plug Replacement in the Periodic Maintenance chapter.

Spark Plug Cleaning and Inspection

- Remove the spark plugs (see Spark Plug Replacement).
- The plug may also be cleaned using a high flash-point solvent and a nonmetal brush (nylon etc.).
- Visually inspect the spark plugs.
- ★ If the spark plug center electrode [A] and/or side electrode [B] are corroded or damaged, or if the insulator [C] is cracked, replace the plug.
- Use the standard spark plug or its equivalent.

Spark Plug: NGK CPR7EA-9

- Measure the gap [D] with a wire-type thickness gauge.
- ★ If the gap is incorrect, carefully bend the side electrode with a tool to obtain the correct gap.

Spark Plug Gap: 0.8 ~ 0.9 mm (0.03 ~ 0.04 in.)

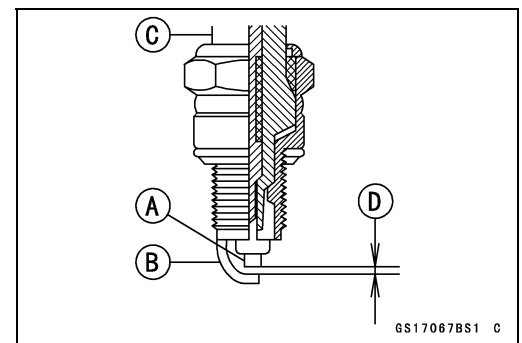

16-56 ELECTRICAL SYSTEM

Ignition System

Crankshaft Sensor Removal

- Remove:
 - Alternator Cover (see Alternator Cover Removal)
 - Bolts [A]
 - Alternator Lead Holder Plate [B]
 - Crankshaft Sensor Lead Grommet [C]
 - Crankshaft Sensor Bolts [D]
- Remove the crankshaft sensor [E] from the alternator cover.

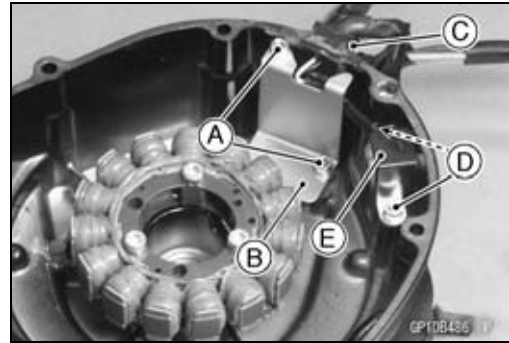

Crankshaft Sensor Installation

- Tighten:
 - Torque - Crankshaft Sensor Bolts: 5.9 N·m (0.60 kgf·m, 52 in·lb)**
- Install the crankshaft sensor lead on the alternator cover (see Stator Coil Installation).

Crankshaft Sensor Inspection

- Remove:
 - Alternator Outer Cover (see Alternator Outer Cover Removal)
 - Crankshaft Sensor Lead Connector [A] (Disconnect)
- Connect a tester between the terminals in the connector.
- ★ If there is more resistance than the specified value, the coil has an open lead and must be replaced. Much less than this resistance means the coil is shorted, and must be replaced.

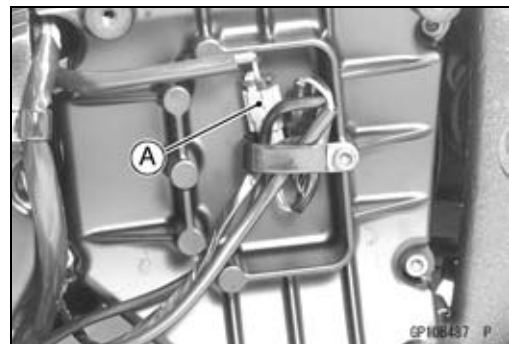

Crankshaft Sensor Resistance

Standard: 376 ~ 564 Ω

- Using the highest resistance range of the tester, measure the resistance between the crankshaft sensor leads and chassis ground.
- ★ Any tester reading less than infinity (∞) indicates a short, necessitating replacement of the crankshaft sensor assembly.

Ignition System

Crankshaft Sensor Peak Voltage Inspection

NOTE

○Be sure the battery is fully charged.

- Remove the alternator outer cover (see Alternator Outer Cover Removal).
- Remove all the spark plug caps but do not remove the spark plugs.
- Disconnect the crankshaft sensor lead connector.
- Connect the peak voltage adapter [A] to a digital meter [B].

Special Tool - Peak Voltage Adapter: 57001-1415

Type: KEK-54-9-B

- Insert the adapter probes into the connector [C] of the crankshaft sensor as shown in the figure.

Connections

| Crankshaft | Adapter (R, +) | Adapter (BK, -) |
|------------|----------------|-----------------|
| Sensor: | Y | BK |

← →

- Turn the ignition switch and the engine stop switch ON.
- Pushing the starter button, turn the engine 4 ~ 5 seconds with the transmission in neutral to measure the crankshaft sensor peak voltage.
- Repeat the measurements 5 or more times.

Crankshaft Sensor Peak Voltage

Standard: 2.5 V or more

- ★ If the reading is less than the specified value, replace the crankshaft sensor.
- ★ If the reading is normal, check the ECU.
- ★ If the peak voltage adapter is not available, the coil can be checked for the broken or badly shorted winding with the tester (see Crankshaft Sensor Inspection).

Interlock Operation Inspection

- Raise the rear wheel off the ground with jack (see Rear Wheel Removal in the Wheels/Tires chapter).

1st Check

- Start the engine to the following conditions.

Condition

Transmission Gear → 1st position

Clutch Lever → Release

Sidestand → Down or Up

- Turn the ignition switch ON and push the starter button.
- Then the starter motor should not turn when the starter system circuit is normality.
- ★ If the engine is start, inspect the starter lockout switch, neutral switch and relay box.
- ★ If their parts are normality replace the ECU.

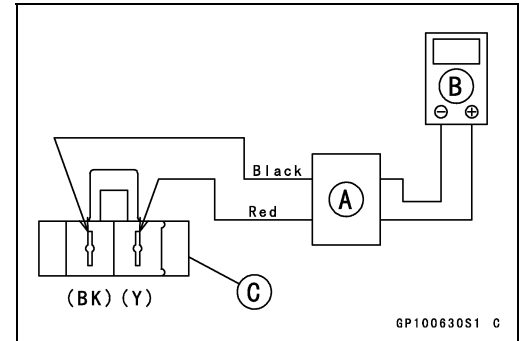

16-58 ELECTRICAL SYSTEM

Ignition System

2nd Check

- Start the engine to the following conditions.

Condition

Transmission Gear → 1st position

Clutch Lever → Pulled in

Sidestand → Up

- Turn the ignition switch ON and push the starter button.
- Then the starter motor should turn when the starter system circuit is normality.
- ★ If the starter motor is not turn, inspect the starter lockout switch, neutral switch and relay box.
- ★ If their parts are normality replace the ECU.

3rd Check

- Inspect the engine for its secure stop after the following operations are completed.
- Run the engine to the following conditions.

Condition

Transmission Gear → 1st Position

Clutch Lever → Release

Sidestand → Up

- Set the sidestand on the ground, then the engine will stop.
- ★ If whichever may not be stopped, inspect the neutral switch, starter lockout switch, sidestand switch and relay box.
- ★ If their parts are normality, replace the ECU.

IC Igniter Inspection

- The IC igniter is built in the ECU [A].
- Refer to the ECU Power Supply Inspection in the Fuel System (DFI) chapter.



Ignition System

Ignition System Troubleshooting

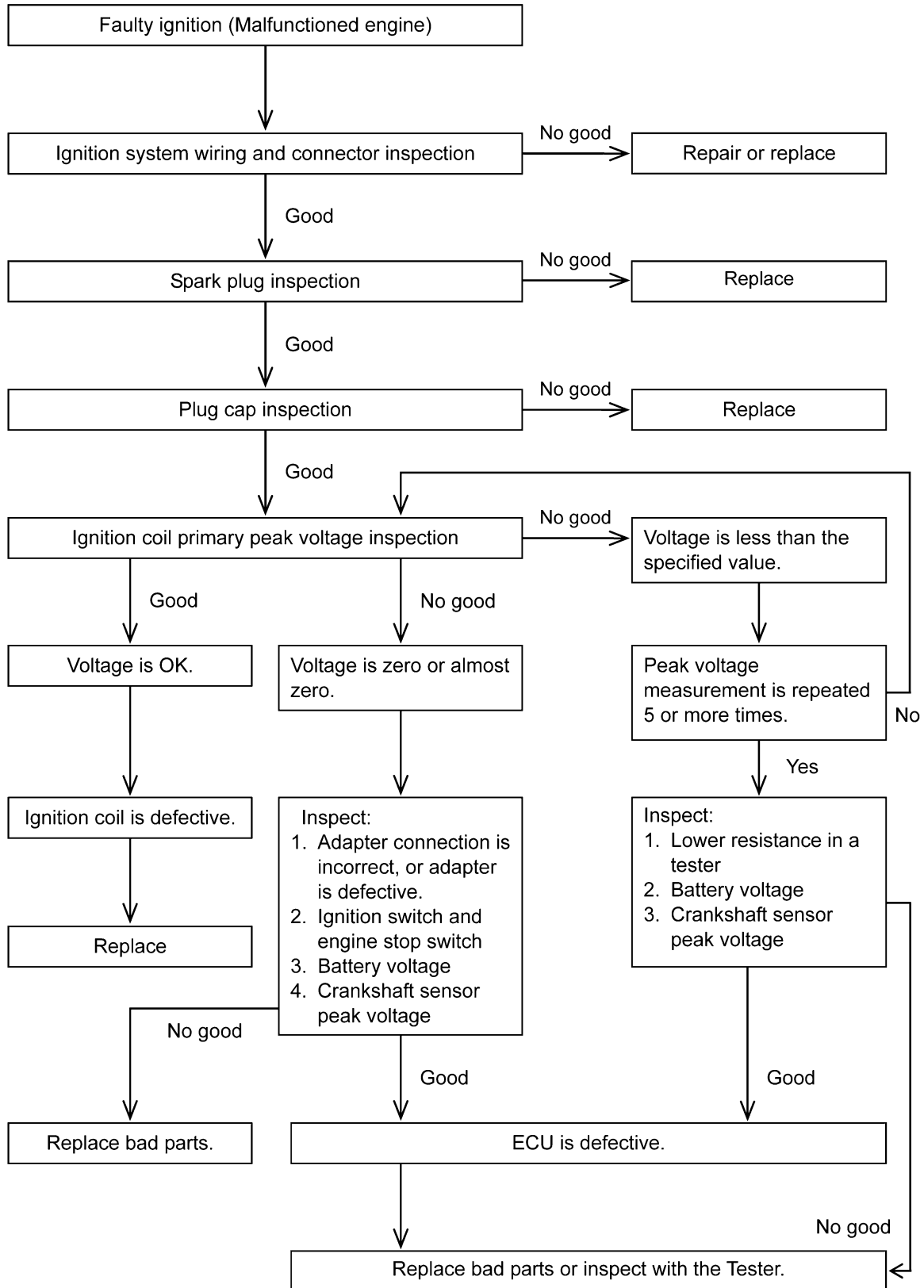

16-60 ELECTRICAL SYSTEM

Ignition System

Ignition System Circuit (VN900C7 ~ C8)

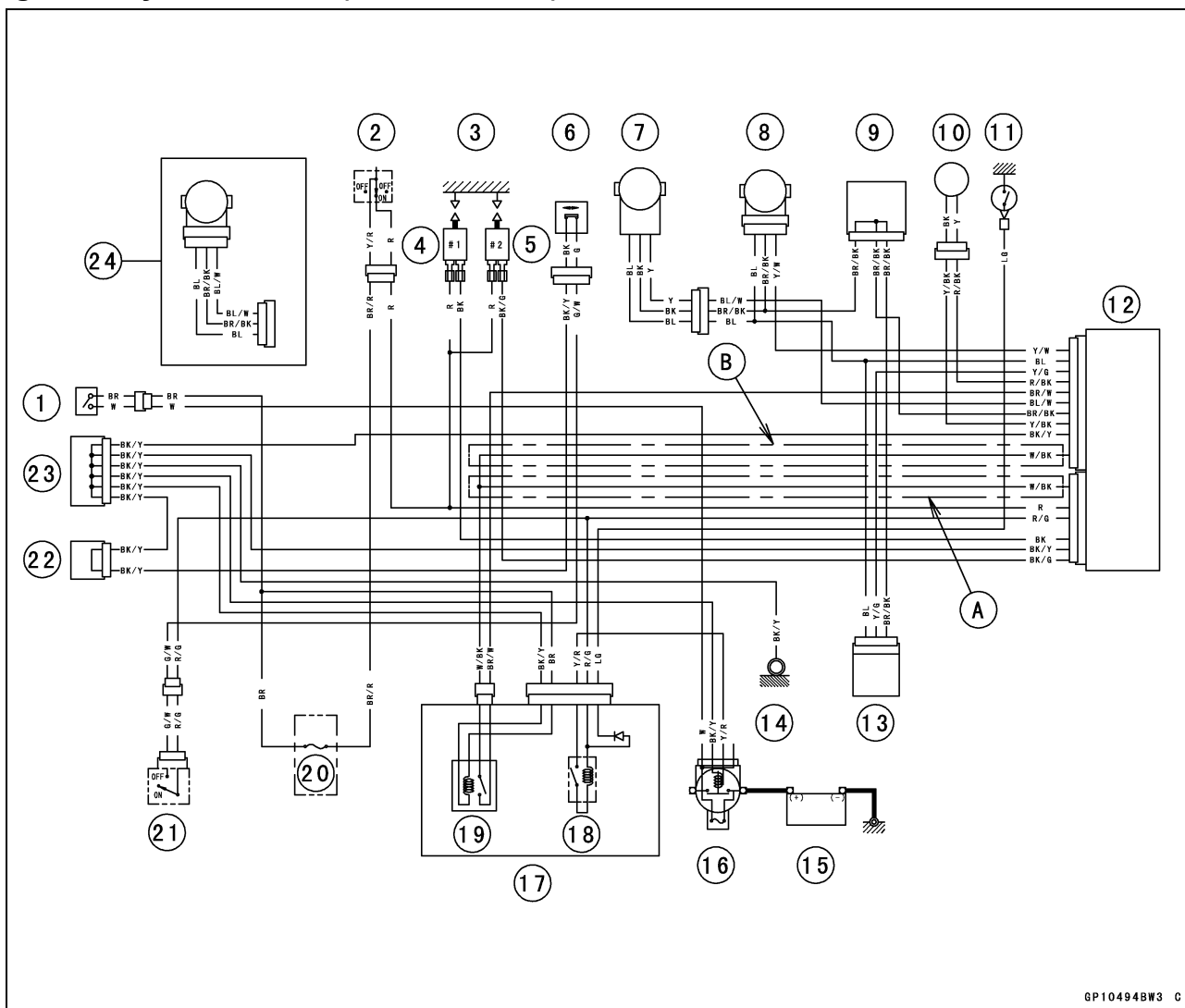

- | | |
|--------------------------------------|----------------------------------|
| 1. Ignition Switch | 13. Vehicle-down Sensor |
| 2. Engine Stop Switch | 14. Frame Ground |
| 3. Spark Plugs | 15. Battery |
| 4. Ignition Coil #1 (Front Cylinder) | 16. Main Fuse 30 A |
| 5. Ignition Coil #2 (Rear Cylinder) | 17. Relay Box |
| 6. Sidestand Switch | 18. Starter Circuit Relay |
| 7. Subthrottle Sensor (VN900C8) | 19. ECU Main Relay |
| 8. Main Throttle Sensor | 20. Ignition Fuse 10 A |
| 9. Joint Connector B | 21. Starter Lockout Switch |
| 10. Crankshaft Sensor | 22. Joint Connector A |
| 11. Neutral Switch | 23. Joint Connector C |
| 12. ECU | 24. Subthrottle Sensor (VN900C7) |

A: Without Oxygen Sensor Equipped Models
 B: Oxygen Sensor Equipped Models

Ignition System

Ignition System Circuit (VN900C9 ~)

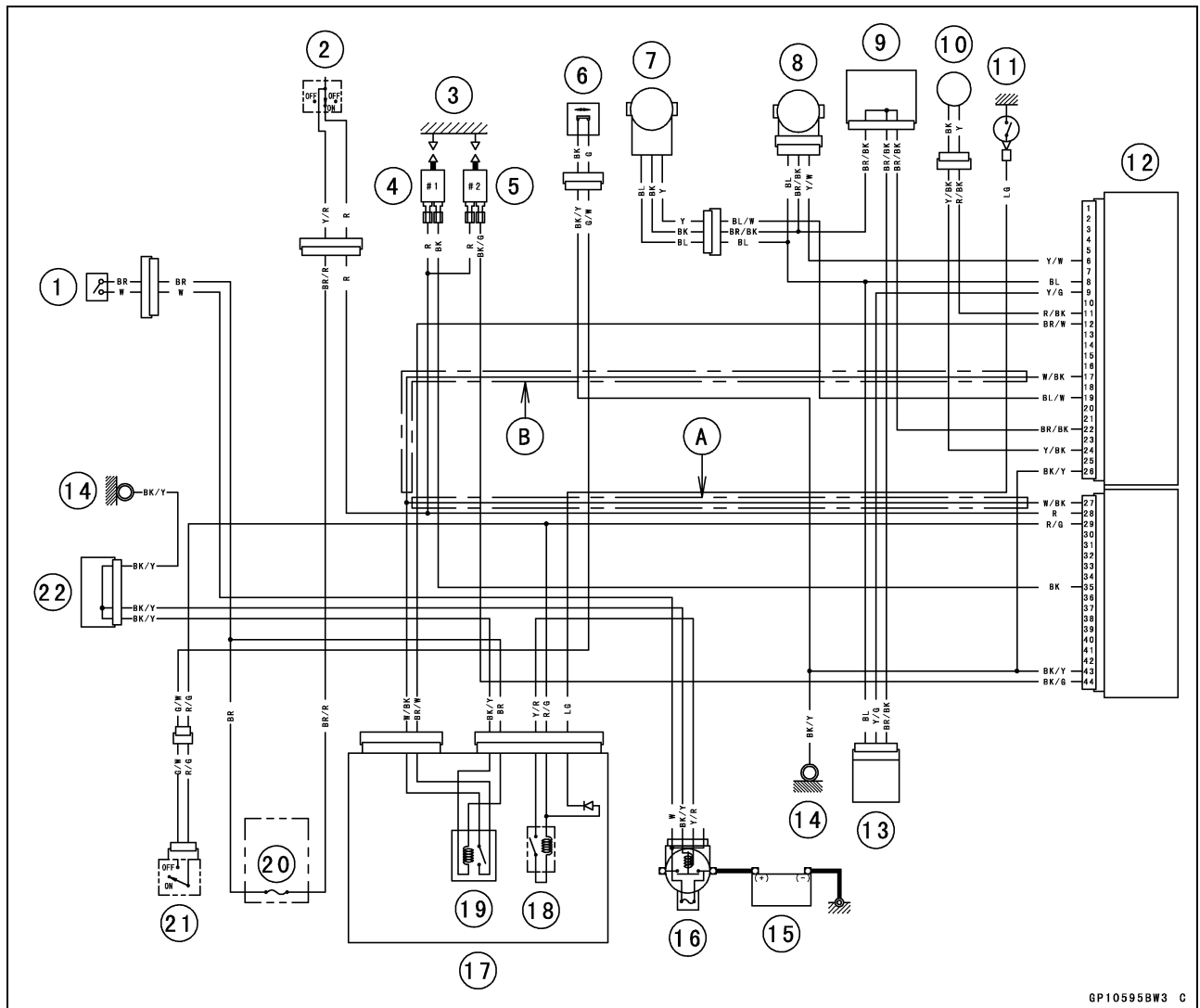

GP10595BW3 C

- | | |
|--------------------------------------|----------------------------|
| 1. Ignition Switch | 13. Vehicle-down Sensor |
| 2. Engine Stop Switch | 14. Frame Ground |
| 3. Spark Plugs | 15. Battery |
| 4. Ignition Coil #1 (Front Cylinder) | 16. Main Fuse 30 A |
| 5. Ignition Coil #2 (Rear Cylinder) | 17. Relay Box |
| 6. Sidestand Switch | 18. Starter Circuit Relay |
| 7. Subthrottle Sensor | 19. ECU Main Relay |
| 8. Main Throttle Sensor | 20. Ignition Fuse 10 A |
| 9. Joint Connector B | 21. Starter Lockout Switch |
| 10. Crankshaft Sensor | 22. Joint Connector A |
| 11. Neutral Switch | 23. Joint Connector C |
| 12. ECU | |

A: Without Oxygen Sensor Equipped Models
 B: Oxygen Sensor Equipped Models

16-62 ELECTRICAL SYSTEM

Electric Starter System

Starter Motor Removal

NOTICE

Do not tap the starter motor shaft or body. Tapping the shaft or body could damage the motor.

- Remove:
 - Regulator/Rectifier (see Regulator/Rectifier Removal)
 - Bolts [A]
 - Front Cross Pipe [B]
- Drain the engine oil (see Engine Oil Change in the Periodic Maintenance chapter).
- Remove the starter motor cable terminal nut [A] and the mounting bolts [B].
- Pull out the starter motor [C].

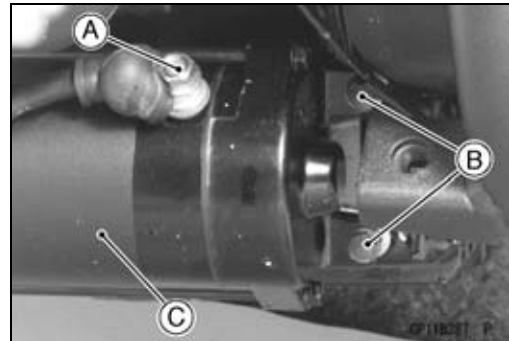
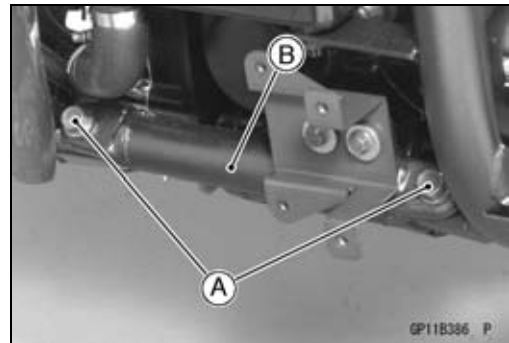

Starter Motor Installation

NOTICE

Do not tap the starter motor shaft or body. Tapping the shaft or body could damage the motor.

- When installing the starter motor, clean the starter motor legs [A] and crankcase [B] where the starter motor is grounded.
- Replace the O-ring with a new one.
- Apply a small amount of grease to the O-ring.
- Tighten:
 - Torque - Starter Motor Mounting Bolts: 9.8 N·m (1.0 kgf·m, 87 in·lb)
 - Starter Motor Cable Terminal Nut: 5.9 N·m (0.60 kgf·m, 52 in·lb)
- Install the removed parts (see appropriate chapters).

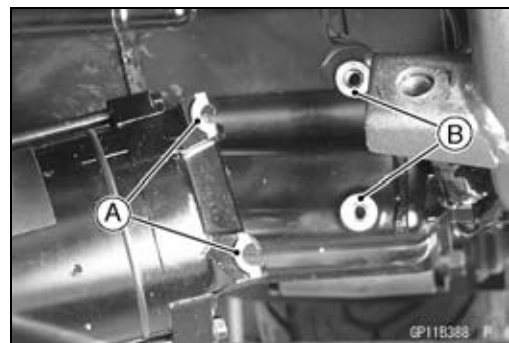

Starter Motor Disassembly

- Remove the starter motor (see Starter Motor Removal).
- Take off the starter motor through bolts [A] and remove both end covers [B] and pull the armature out of the yoke [C].

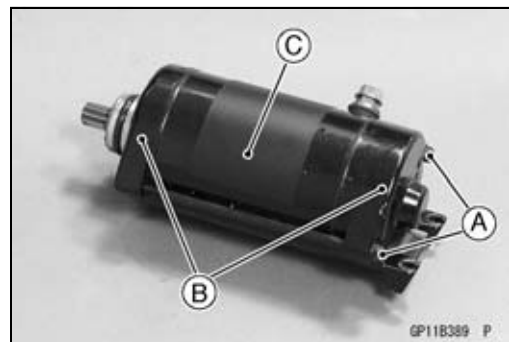

Electric Starter System

- Remove:
 - Terminal Locknut and Washers
 - O-ring
- Remove the brush plate assy [A] from the yoke [B].

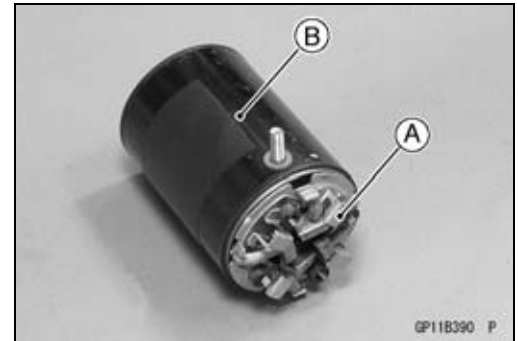

- Remove the brush plate [A] from the terminal bolt assembly [B].

NOTE

○Do not remove the negative carbon brushes from the brush plate.

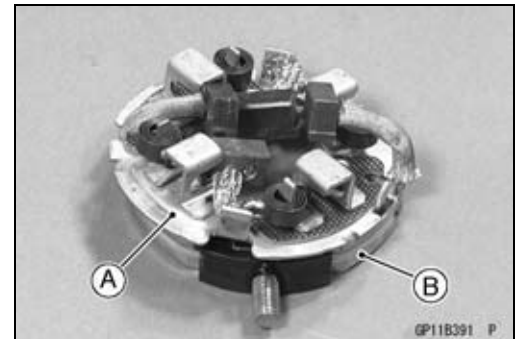

Starter Motor Assembly

- Install the terminal assembly [A] to the yoke [B].
- Install the brush plate assy to the yoke.

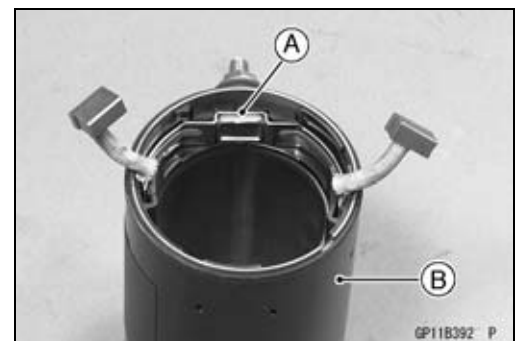

- Install the brush plate [A] on the terminal bolt assembly.

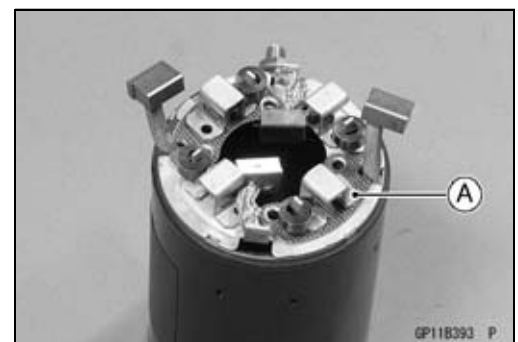

- Insert the suitable plates [A] between the springs and brush holders.
- Install the armature [B], and pull out the suitable plates to release the springs.

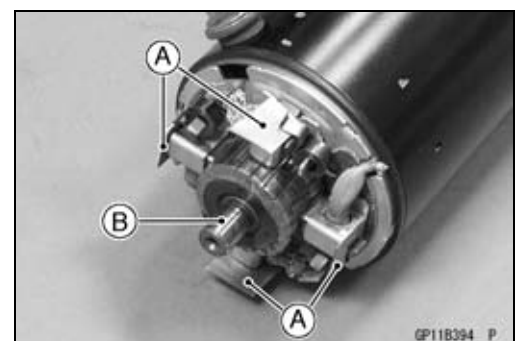

16-64 ELECTRICAL SYSTEM

Electric Starter System

- Install the new O-ring [A] as shown in the figure.
- Install the washers [B] and terminal locknut [C].
- Tighten:

Torque - Starter Motor Terminal Locknut: 11 N·m (1.1 kgf·m, 97 in·lb)

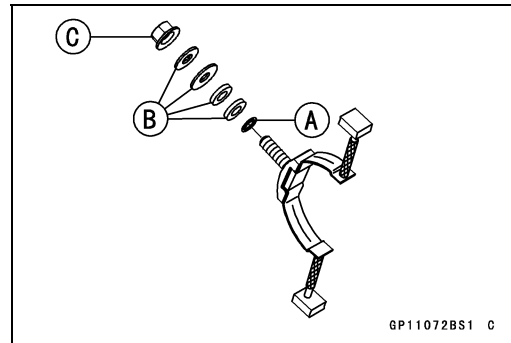

- Align the lines [A] on the yoke with the end cover lines [B].
- Tighten the through bolts.

Torque - Starter Motor Through Bolts: 4.9 N·m (0.50 kgf·m, 43 in·lb)

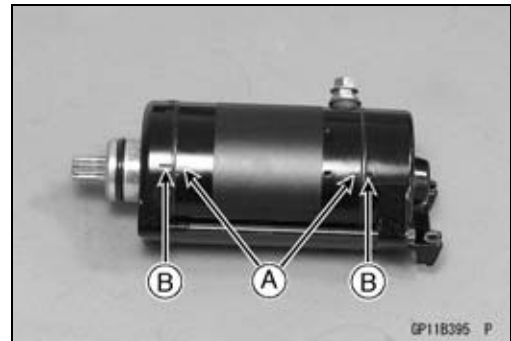

Brush Inspection

- Measure the length of each brush [A].
- ★ If any is worn down to the service limit, replace the brush plate assy [B] and the terminal bolt assy [C].

Starter Motor Brush Length

Standard: 12 mm (0.47 in.)

Service Limit: 6.0 mm (0.24 in.)

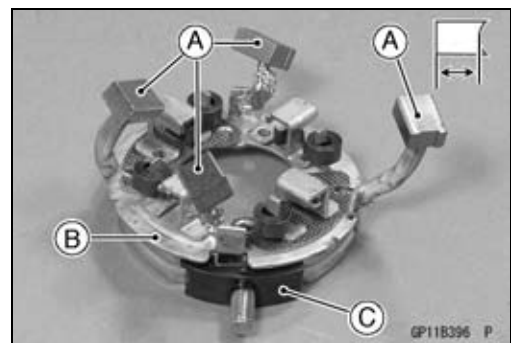

Commutator Cleaning and Inspection

- Smooth the commutator surface [A] if necessary with fine emery cloth [B], and clean out the grooves.

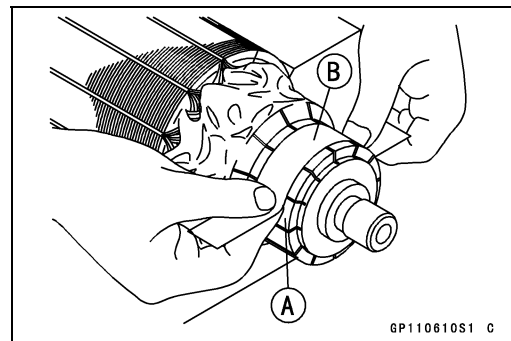

- Measure the diameter [A] of the commutator [B].
- ★ If the commutator diameter is less than the service limit, replace the starter motor with a new one .

Starter Motor Commutator Diameter

Standard: 28 mm (1.10 in.)

Service Limit: 27 mm (1.06 in.)

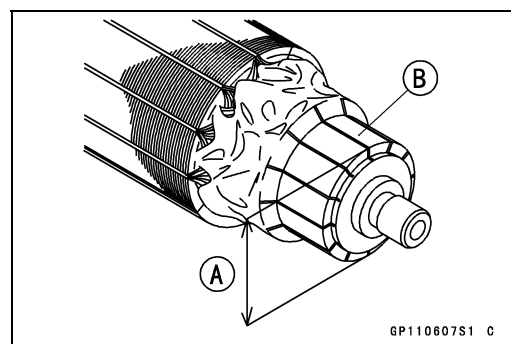

Electric Starter System

Armature Inspection

- Using a tester, measure the resistance between any two commutator segments [A].
- ★ If there is a high resistance or no reading (∞) between any two segments, a winding is open and the starter motor must be replaced.
- Using the highest tester range, measure the resistance between the segments and the shaft [B].
- ★ If there is any reading at all, the armature has a short and the starter motor must be replaced.

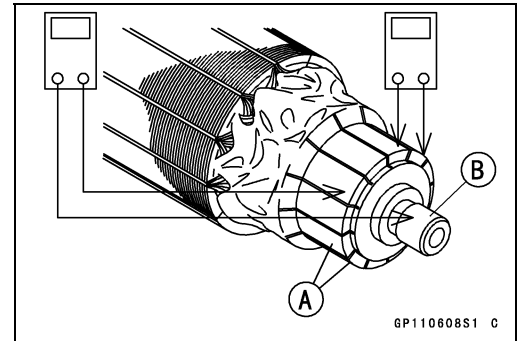

NOTE

○ Even if the foregoing checks show the armature to be good, it may be defective in some manner not readily detectable with the tester. If all other starter motor and starter motor circuit components check good, but the starter motor still does not turn over or only turns over weakly, replace the starter motor with a new one.

Brush Lead Inspection

- Using a tester, measure the resistance as shown in the figure.
Terminal Bolt and Positive Brushes [A]
Brush Plate and Negative Brushes [B]
- ★ If there is not close to zero ohms, the brush lead has an open. Replace the terminal bolt assy and/or the brush plate assy.

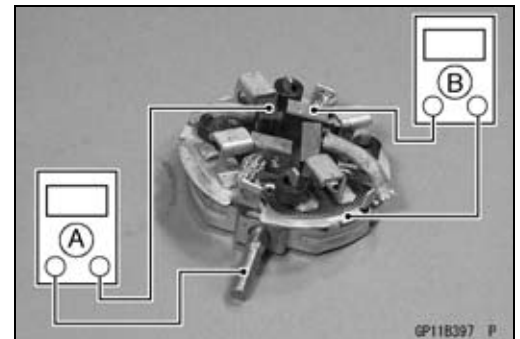

Brush Plate and Terminal Bolt Inspection

- Using a tester, measure the resistance as shown in the figure.
Terminal Bolt and Brush Plate [A]
Terminal Bolt and Negative Brush Holders [B]
Terminal Bolt and Yoke [C]
- ★ If there is any reading, the brush plate assy and/or terminal bolt assy have a short. Replace the brush plate assy and the terminal bolt assy.

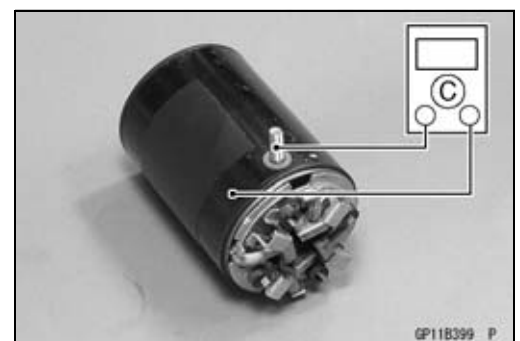
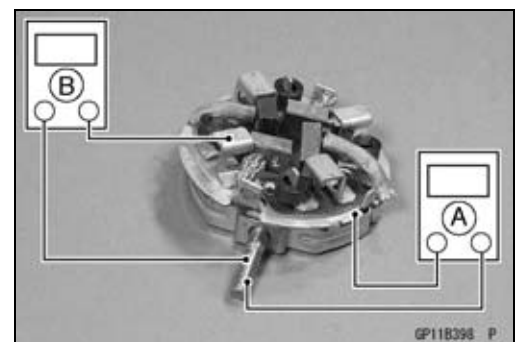

16-66 ELECTRICAL SYSTEM

Electric Starter System

Starter Relay Inspection

- Remove the right side cover (see Right Side Cover Removal in the Frame chapter).
- Disconnect the connector [A].
- Disconnect the starter motor cable [B] and battery positive (+) cable [C] from the starter relay [D].

NOTICE

The battery positive (+) cable with the rubber cap is connected directly to the battery positive (+) terminal even when the ignition switch off, so take care not to short the removed cable to chassis ground.

- Connect a tester [A] and 12 V battery [B] to the starter relay [C] as shown in the figure.
- ★ If the relay does not work as specified, the relay is defective. Replace the relay.

Testing Relay

Criteria: When battery is connected → 0Ω
 When battery is disconnected → $\infty \Omega$

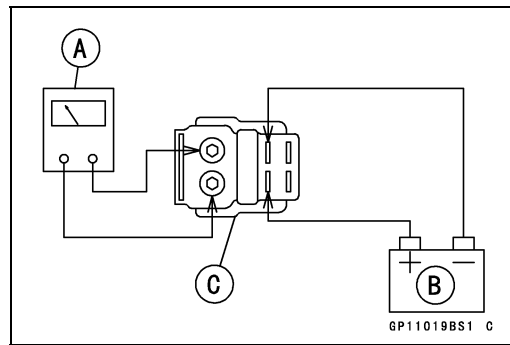
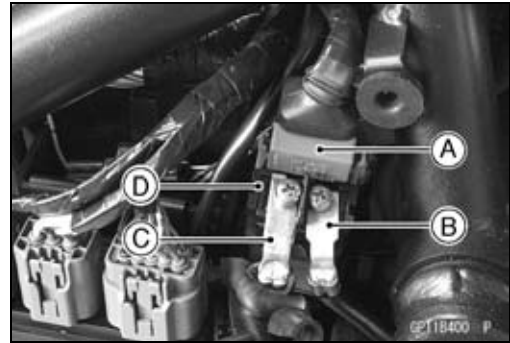

Electric Starter System

Electric Starter Circuit (VN900C7 ~ C8)

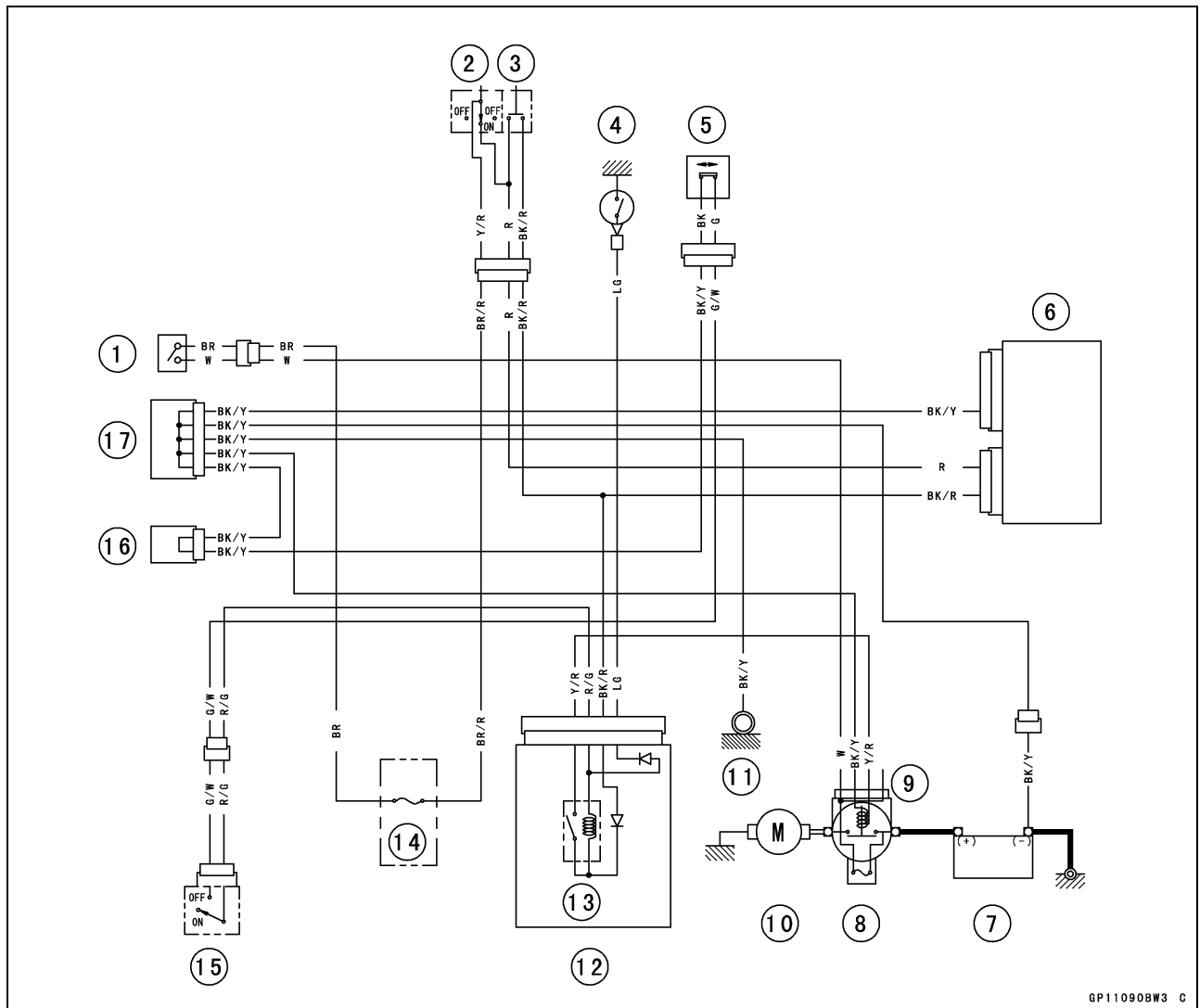

GP11090BW3 C

1. Ignition Switch
2. Engine Stop Switch
3. Starter Button
4. Neutral Switch
5. Sidestand Switch
6. ECU
7. Battery
8. Main Fuse 30 A
9. Starter Relay
10. Starter Motor
11. Frame Ground
12. Relay Box
13. Starter Circuit Relay
14. Ignition Fuse 10 A
15. Starter Lockout Switch
16. Joint Connector A
17. Joint Connector C

16-68 ELECTRICAL SYSTEM

Electric Starter System

Electric Starter Circuit (VN900C9 ~)

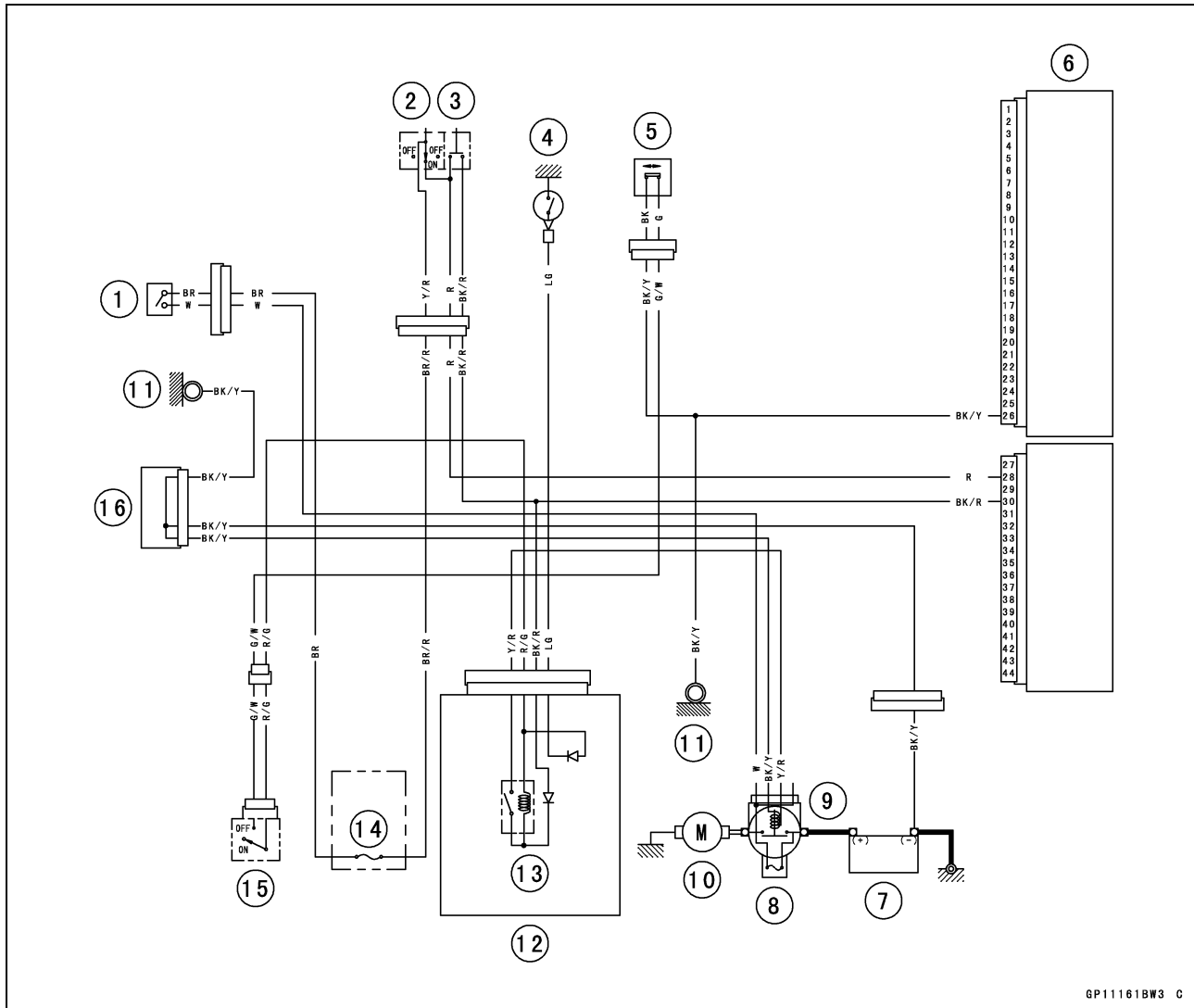

1. Ignition Switch
2. Engine Stop Switch
3. Starter Button
4. Neutral Switch
5. Sidestand Switch
6. ECU
7. Battery
8. Main Fuse 30 A
9. Starter Relay
10. Starter Motor
11. Frame Ground
12. Relay Box
13. Starter Circuit Relay
14. Ignition Fuse 10 A
15. Starter Lockout Switch
16. Joint Connector A
17. Joint Connector C

Lighting System

This models adopt the daylight system and has a headlight relay in the relay box. The headlight does not go on when the ignition switch and the engine stop switch are first turned on. The headlight comes on after the starter button is released and stays on until the ignition switch is turned off. The headlight will go out momentarily whenever the starter button is pressed and come back on when the button is released.

Headlight Beam Horizontal Adjustment

- Refer to the Headlight Aiming Inspection in the Periodic Maintenance chapter.

Headlight Beam Vertical Adjustment

- Refer to the Headlight Aiming Inspection in the Periodic Maintenance chapter.

Headlight Bulb Replacement

- Remove the headlight rim screws [A] on both sides.



- Pull the headlight unit [A] and drop it out.
- Pull the headlight connector [B].
- Remove the headlight dust cover [C].

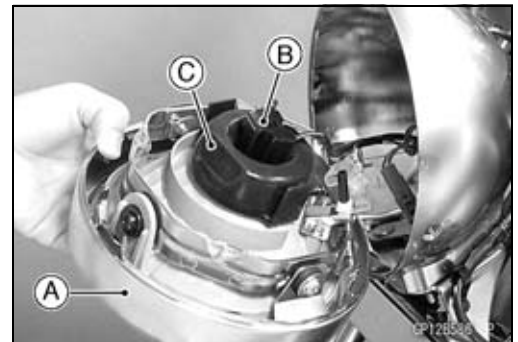

- Push the hook [A] to unlock.

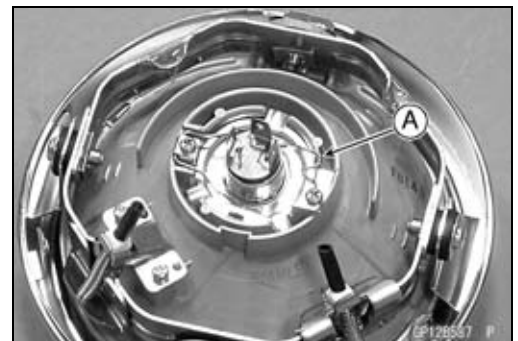

16-70 ELECTRICAL SYSTEM

Lighting System

- Take out the bulb [A].

NOTICE

When handling the quartz-halogen bulb, never touch the glass portion with bare hands. Always use a clean cloth. Oil contamination from hands or dirty rags can reduce bulb life or cause the bulb to explode. Use the correct type of headlight bulb with specified voltage and wattage only.

NOTE

○ Clean off any contamination that inadvertently gets on the bulb with alcohol or a soap and water solution.

- Replace the headlight bulb.
- Fit the dust cover [A] with the TOP mark [B] upward onto the bulb [C] firmly as shown in the figure.

Good [D]
Bad [E]

- Fit the hook [A] to the slot [B].
- Tighten:
Torque - Headlight Rim Screws: 2.9 N·m (0.30 kgf·m, 26 in·lb)
- After installation, adjust the headlight aim (see Headlight Aiming Inspection in the Periodic Maintenance chapter).

Headlight Body Removal

- Remove the headlight rim screws [A] on both sides.
- Pull the headlight unit [B] and drop it out.
- Pull the headlight connector.

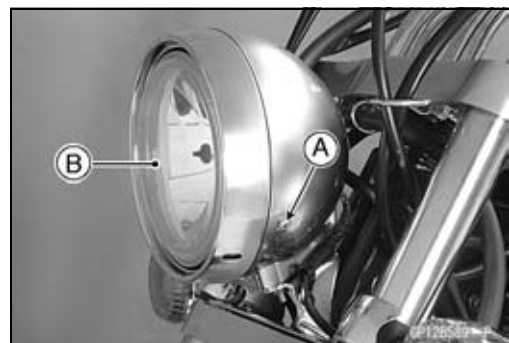
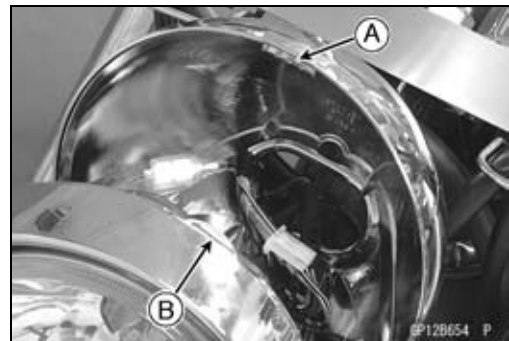
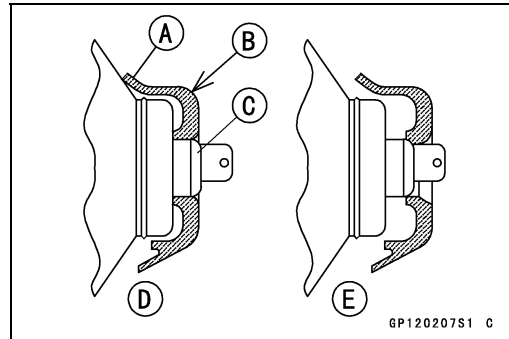
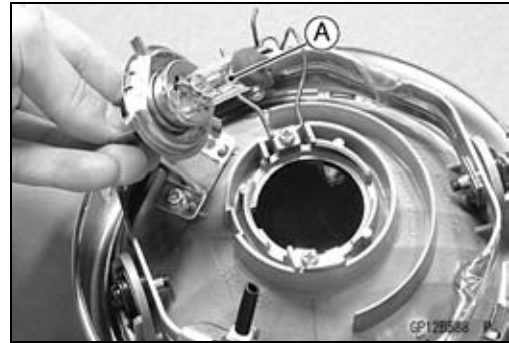

Lighting System

Other than GB Models

- Remove the headlight body nuts [A], then take off the body [B].

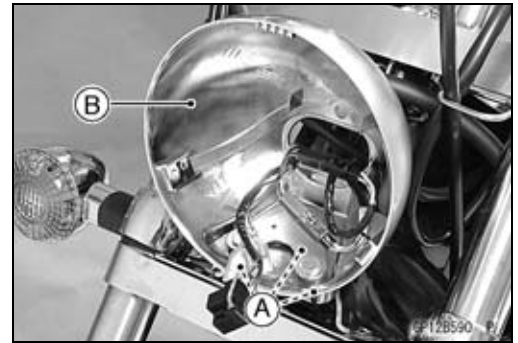

GB Model

- Remove the headlight body bolts [A] and nuts [B], then take off the body [C].

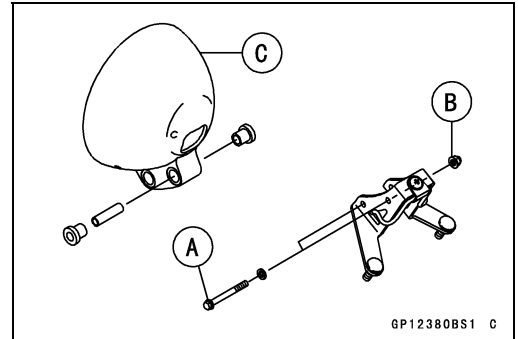

City Light Bulb Replacement (EUR, SEA-B1 (VN900CC ~), SEA-B3 (VN900CE), BR and PH Models)

- Remove the headlight unit (see Headlight Bulb Replacement).
- Pull out the socket [A] together with the bulb.

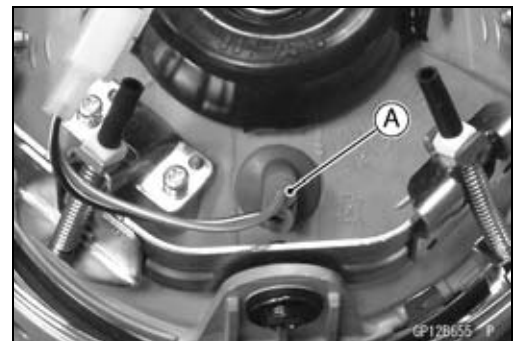

- Remove the wedge-base type bulb [A], pull the bulb straight out of the socket [B].
- Replace the bulb with a new one.

NOTICE

Do not turn the bulb. Pull the bulb out to prevent damage to the bulb. Do not use bulb rated for greater wattage than the specified value.

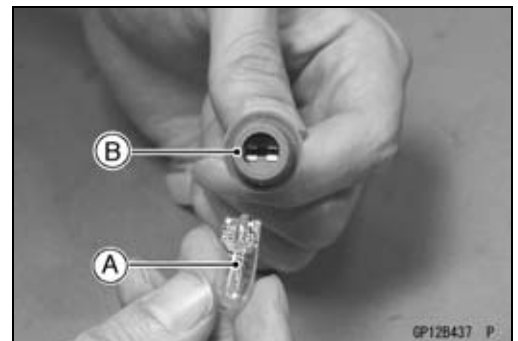

Tail/Brake Light Removal/Installation

- Remove:
 - Rear Fender and Flap (see Flap and Rear Fender Removal in the Frame chapter)
 - Nuts [A]
- Remove the tail/brake light from the rear fender.
- Tighten:
 - Torque - Tail/Brake Light Unit Mounting Nuts: 5.9 N·m (0.60 kgf·m, 52 in·lb)



16-72 ELECTRICAL SYSTEM

Lighting System

Tail/Brake Light Bulb Replacement

- Unscrew the lens screw [A].
- Pull the lens [B] off.
- Push the bulb [A] in, turn it counterclockwise [B], and pull it out.
- Replace the bulb with a new one.
- With the front pin [A] up and the rear pin [B] down, insert the new bulb by aligning the front pin with the upper groove [C] in the walls of the socket [D].
- Push the bulb in, turn it clockwise, and release it. It should lock in position.
- Put the hooks [A] to the edges [B] of the tail/brake light cover.
- Tighten the lens screw.
- Be careful not to overtighten them.

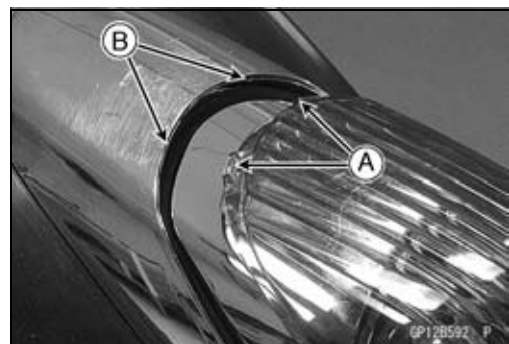
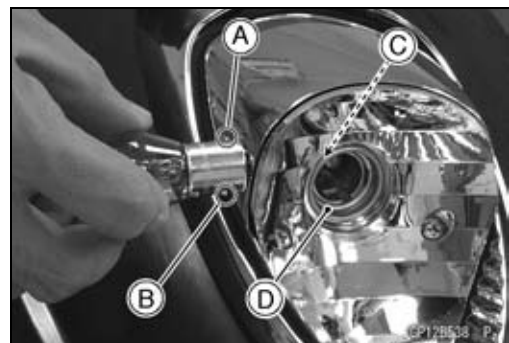
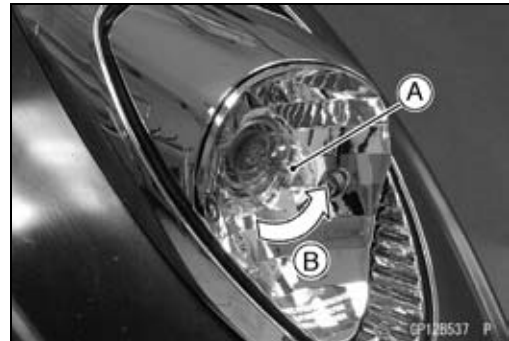
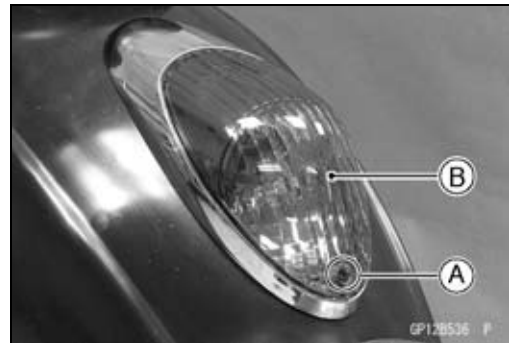

License Plate Light Bulb Replacement

- Remove:
 - Screws [A]
 - License Plate Light Cover [B]

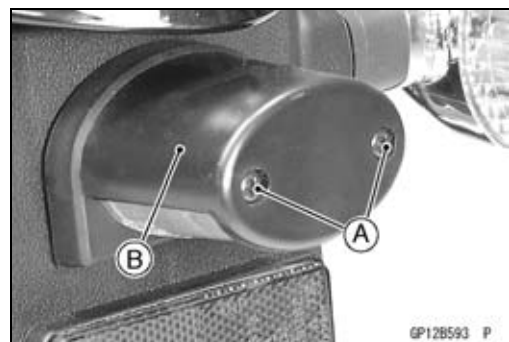

Lighting System

- Push the bulb [A] in, turn it counterclockwise [B], and pull it out.

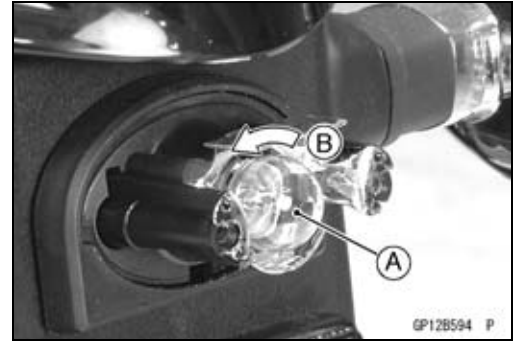

- Insert the new bulb [A] by aligning the pins [B] with the groove in the walls of the socket [C].

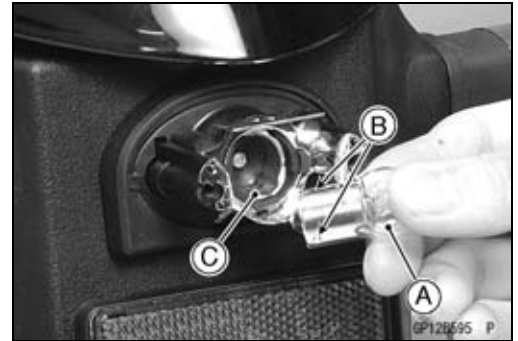

16-74 ELECTRICAL SYSTEM

Lighting System

Headlight/Tail Light Circuit (VN900C7 ~ C8)

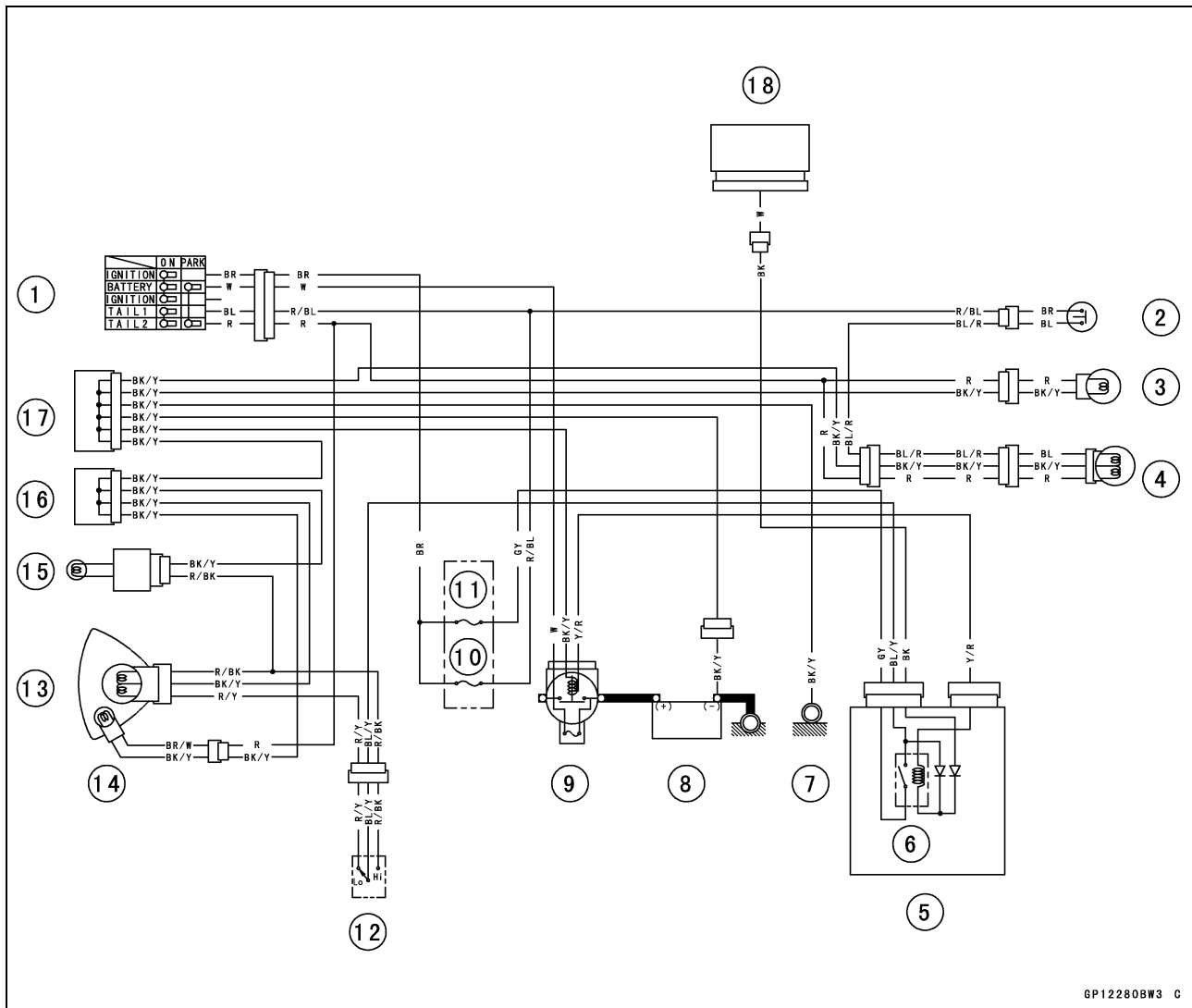

GP12280BW3 C

- | | |
|------------------------|-------------------------------|
| 1. Ignition Switch | 10. Tail Light Fuse 10 A |
| 2. Rear Brake Switch | 11. Headlight Fuse 10 A |
| 3. License Plate Light | 12. Dimmer Switch |
| 4. Tail/Brake Light | 13. Headlight |
| 5. Relay Box | 14. City Light (EUR Models) |
| 6. Headlight Relay | 15. High Beam Indicator Light |
| 7. Frame Ground | 16. Joint Connector A |
| 8. Battery | 17. Joint Connector C |
| 9. Main Fuse 30 A | 18. Regulator/Rectifier |

Lighting System

Headlight/Tail Light Circuit (VN900C9 ~)

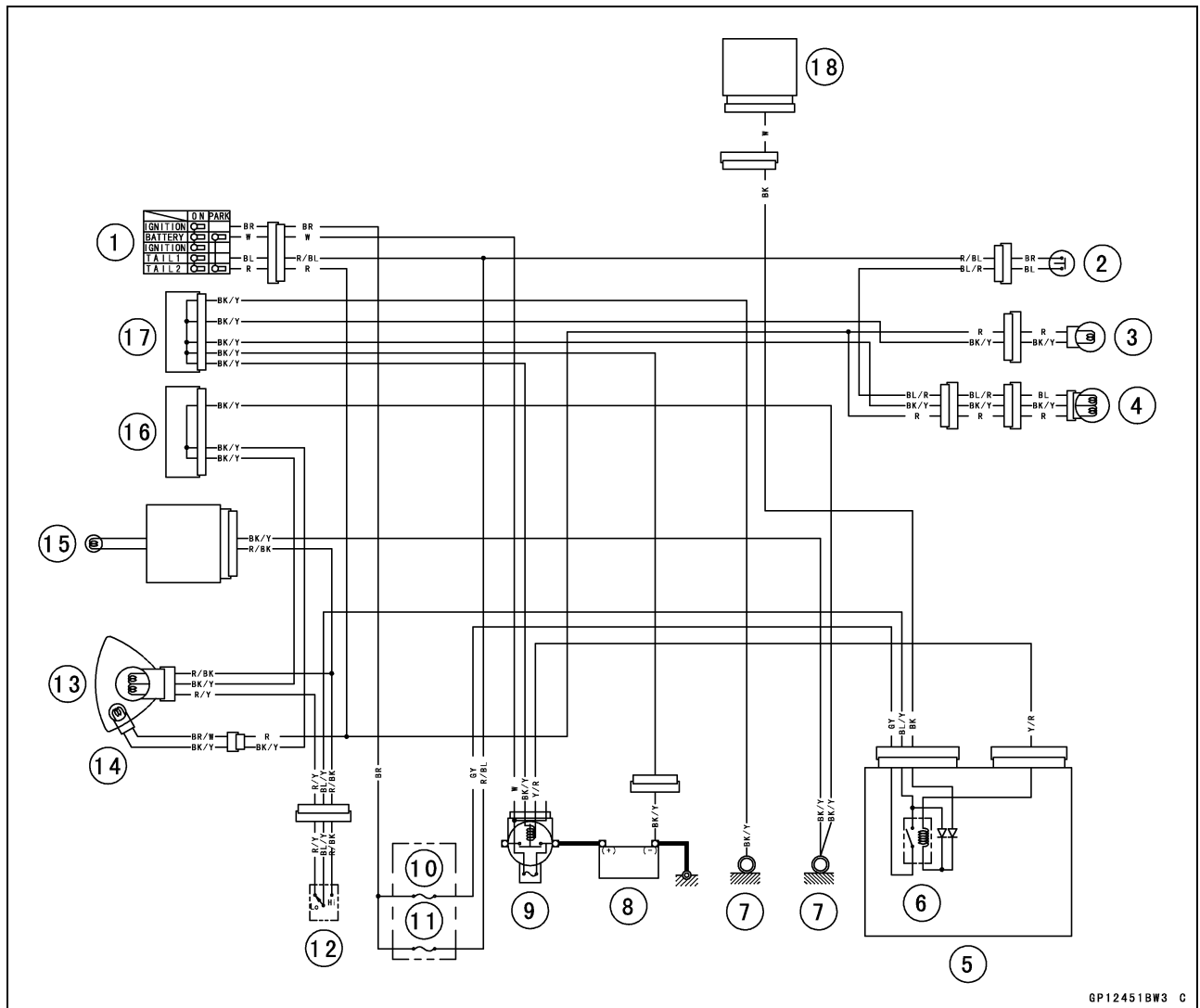

GP12451BW3 C

- | | |
|------------------------|--|
| 1. Ignition Switch | 10. Tail Light Fuse 10 A |
| 2. Rear Brake Switch | 11. Headlight Fuse 10 A |
| 3. License Plate Light | 12. Dimmer Switch |
| 4. Tail/Brake Light | 13. Headlight |
| 5. Relay Box | 14. City Light (EUR, SEA-B1 (VN900CC ~), SEA-B3 (VN900CE), BR and PH Models) |
| 6. Headlight Relay | 15. High Beam Indicator Light |
| 7. Frame Ground | 16. Joint Connector A |
| 8. Battery | 17. Joint Connector C |
| 9. Main Fuse 30 A | 18. Regulator/Rectifier |

Turn Signal Light Bulb Replacement

- Remove:
 - Turn Signal Light Lens Screws [A]
 - Lens [B]

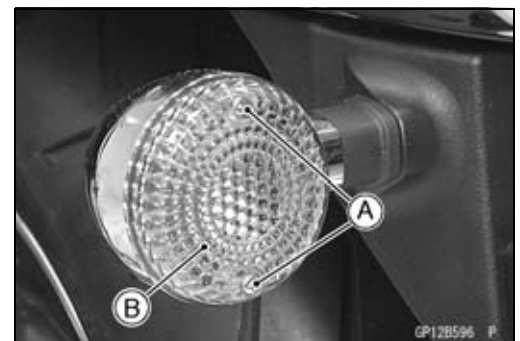

GP128596 P

16-76 ELECTRICAL SYSTEM

Lighting System

- Push the bulb [A] in the socket and turn the bulb counter-clockwise.
- Replace the bulb.



- Insert the new bulb [A] by aligning the pins [B] with the groove in the walls of the socket [C].



Turn Signal Relay Inspection

- Remove:
 - Seat (see Seat Removal in the Frame chapter)
 - Tool Box (see Tool Box Removal in the Frame chapter)
 - Turn Signal Relay [A]



- Connect one 12 V battery and turn signal lights as indicated in the figure, and count how many times the lights flash for one minute.
 - Turn Signal Relay [A]
 - Turn Signal Lights [B]
 - 12 V Battery [C]

★ If the lights do not flash as specified, replace the turn signal relay.

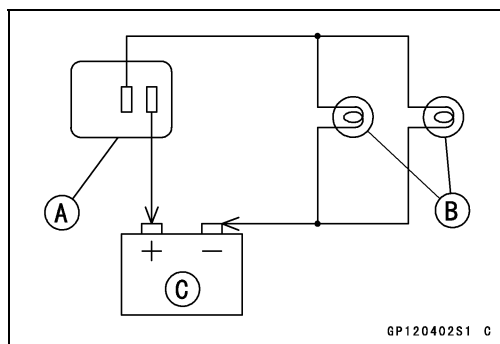

Testing Turn Signal Relay

| Load | | Flashing Times (c/m*) |
|----------------------------------|-------------|-----------------------|
| The Number of Turn Signal Lights | Wattage (W) | |
| 1** | 21 or 23 | 140 ~ 250 |
| 2 | 42 or 46 | 75 ~ 95 |

(*): Cycle(s) per minute

(**): Correspond to "one light burned out".

Lighting System

Turn Signal Light Circuit (VN900C7 ~ C8)

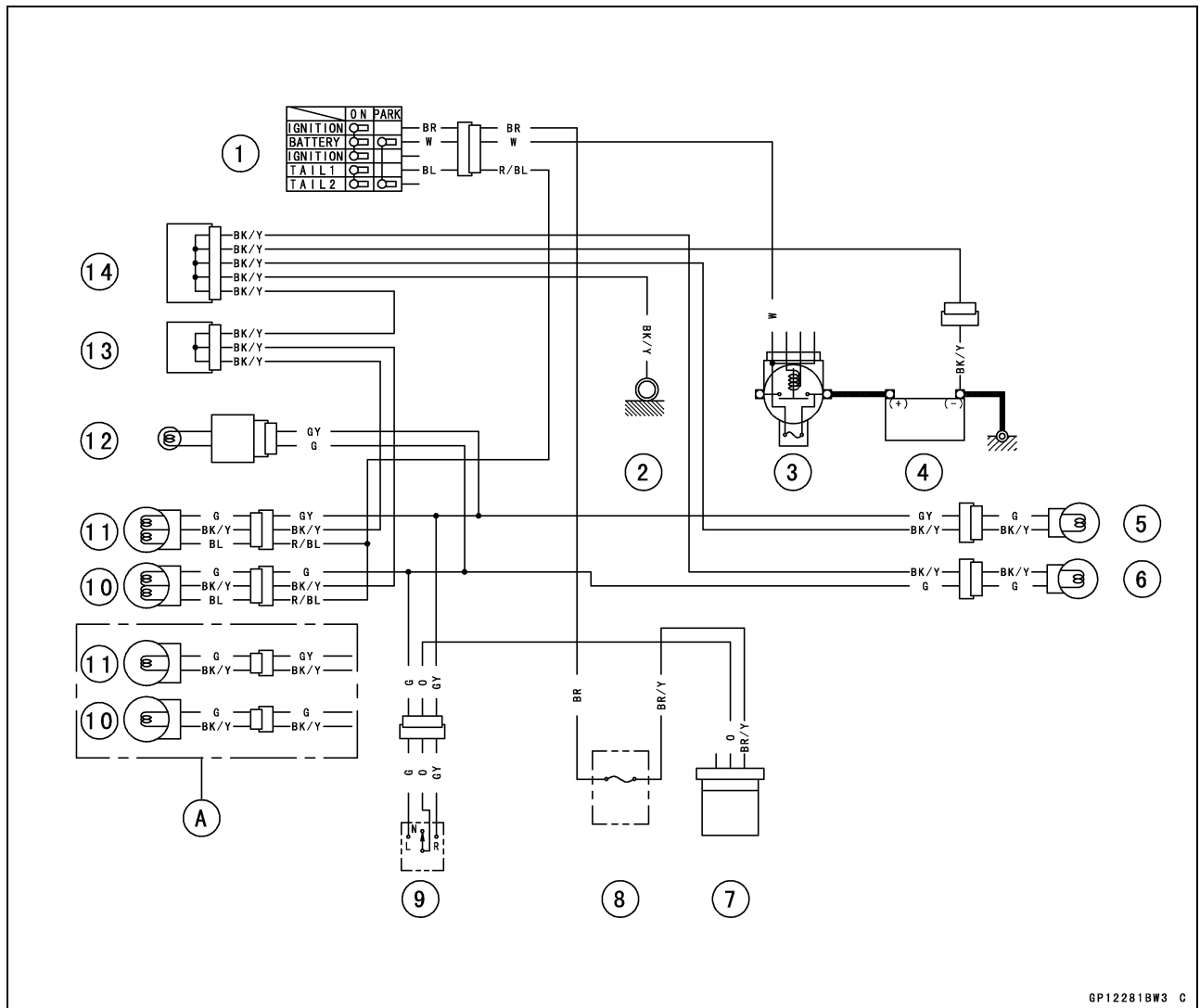

1. Ignition Switch
 2. Frame Ground
 3. Main Fuse 30 A
 4. Battery
 5. Rear Right Turn Signal Light
 6. Rear Left Turn Signal Light
 7. Turn Signal Relay
 8. Turn Signal Relay Fuse 10 A
 9. Turn Signal Switch
 10. Front Left Turn Signal Light
 11. Front Right Turn Signal Light
 12. Turn Signal Indicator Light
 13. Joint Connector A
 14. Joint Connector C
- A: EUR and AU Models

16-78 ELECTRICAL SYSTEM

Lighting System

Turn Signal Light Circuit (VN900C9 ~)

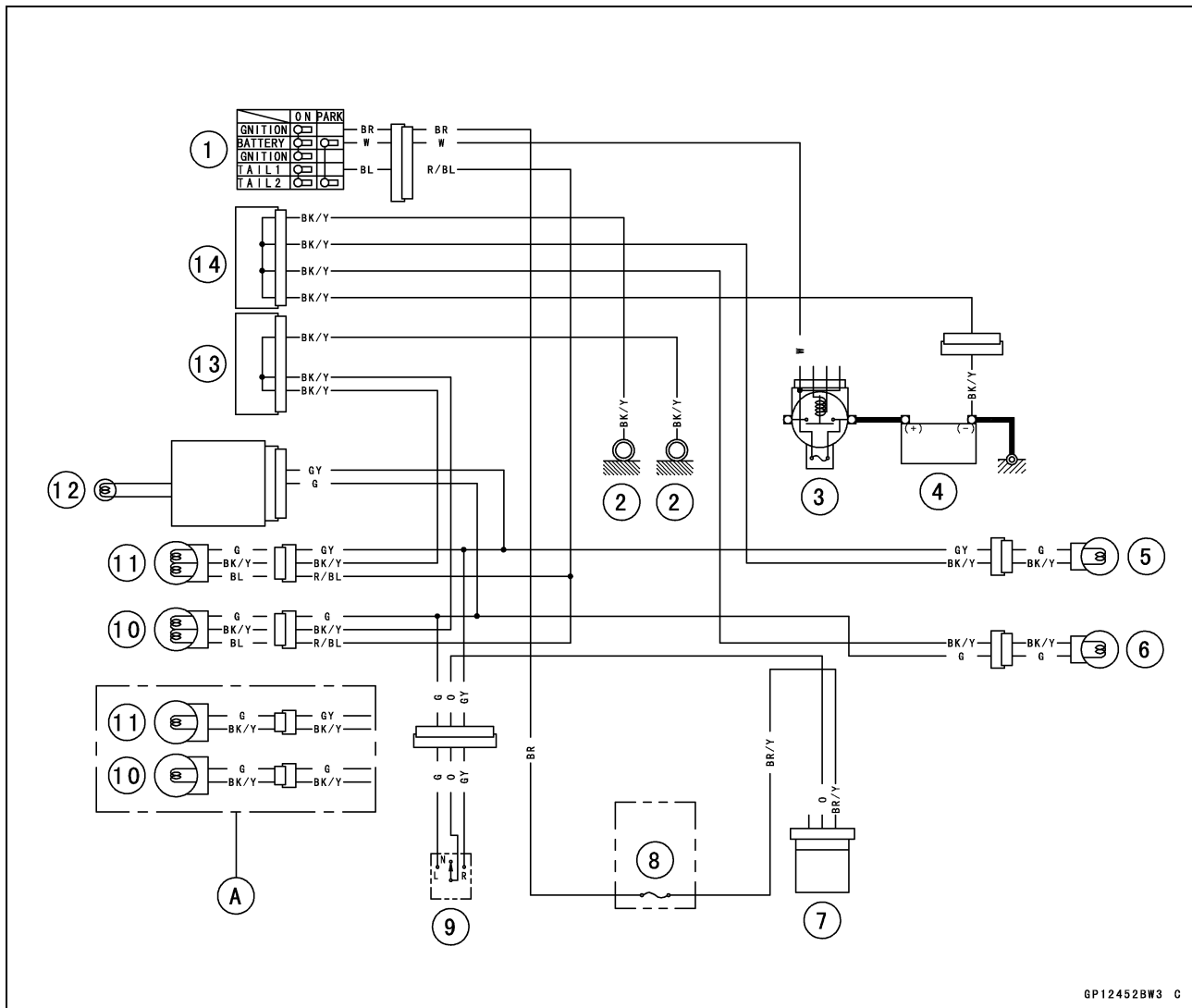

GP12452BW3 C

1. Ignition Switch
2. Frame Ground
3. Main Fuse 30 A
4. Battery
5. Rear Right Turn Signal Light
6. Rear Left Turn Signal Light
7. Turn Signal Relay
8. Turn Signal Relay Fuse 10 A
9. Turn Signal Switch
10. Front Left Turn Signal Light
11. Front Right Turn Signal Light
12. Turn Signal Indicator Light
13. Joint Connector A
14. Joint Connector C

A: EUR and AU Models

Air Switching Valve

Air Switching Valve Operation Test

- Refer to the Air Suction System Damage Inspection in the Periodic Maintenance chapter.

Air Switching Valve Unit Test

- Remove the air switching valve (see Air Switching Valve Removal in the Engine Top End chapter).
- Connect a digital meter to the air switching valve terminals as shown in the figure.

Air Switching Valve Resistance

Standard: 18 ~ 22 Ω at 20°C (68°F)

- ★ If the resistance reading is except the specified value, replace it with a new one.

- Connect the 12 V battery [A] to the air switching valve terminals as shown in the figure.

- Blow the air to the inlet air duct [A], and make sure does not flow the blown air from the outlet air ducts [B].

- Disconnect the 12 V battery.
- Blow the air to the inlet air duct [A] again, and make sure flow the blown air from the outlet air ducts [B].
- ★ If the air switching valve does not operate as described, replace it with a new one.

NOTE

- To check air flow through the air switching valve, just blow through the air cleaner hose [C].

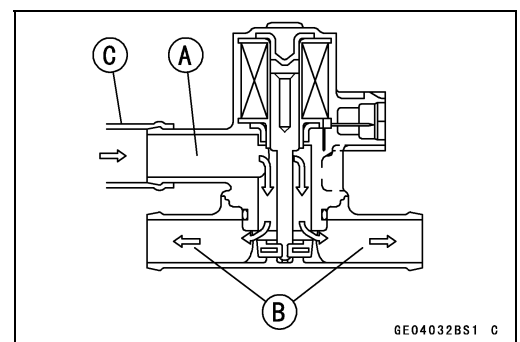
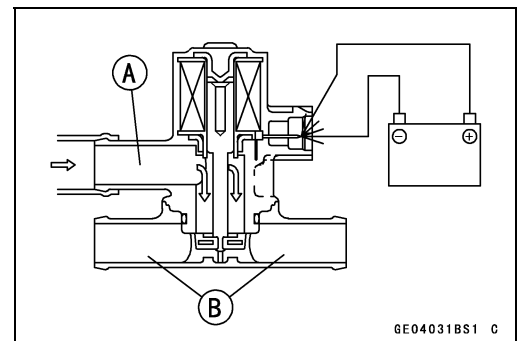
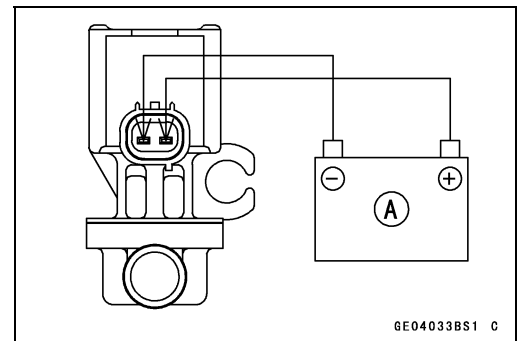
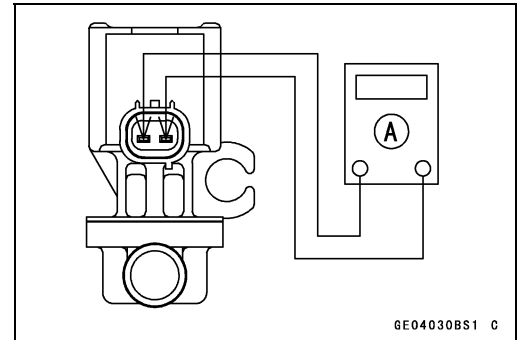

16-80 ELECTRICAL SYSTEM

Radiator Fan System

Fan Motor Inspection

- Remove the fuel tank (see Fuel Tank Removal in the Fuel System (DFI) chapter).
- Disconnect the 2-pin connector [A] in the fan motor leads.
- Using an auxiliary leads, supply battery [B] power to the fan motor.
- ★ If the fan does not rotate, the fan motor is defective and must be replaced.

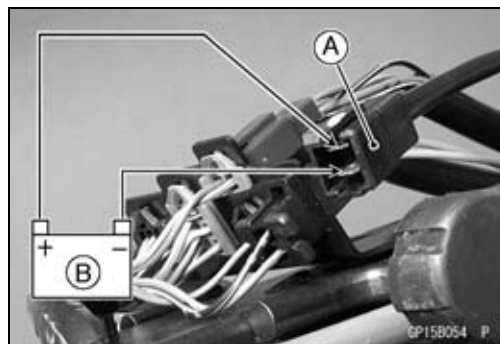

Radiator Fan Circuit (VN900C7 ~ C8)

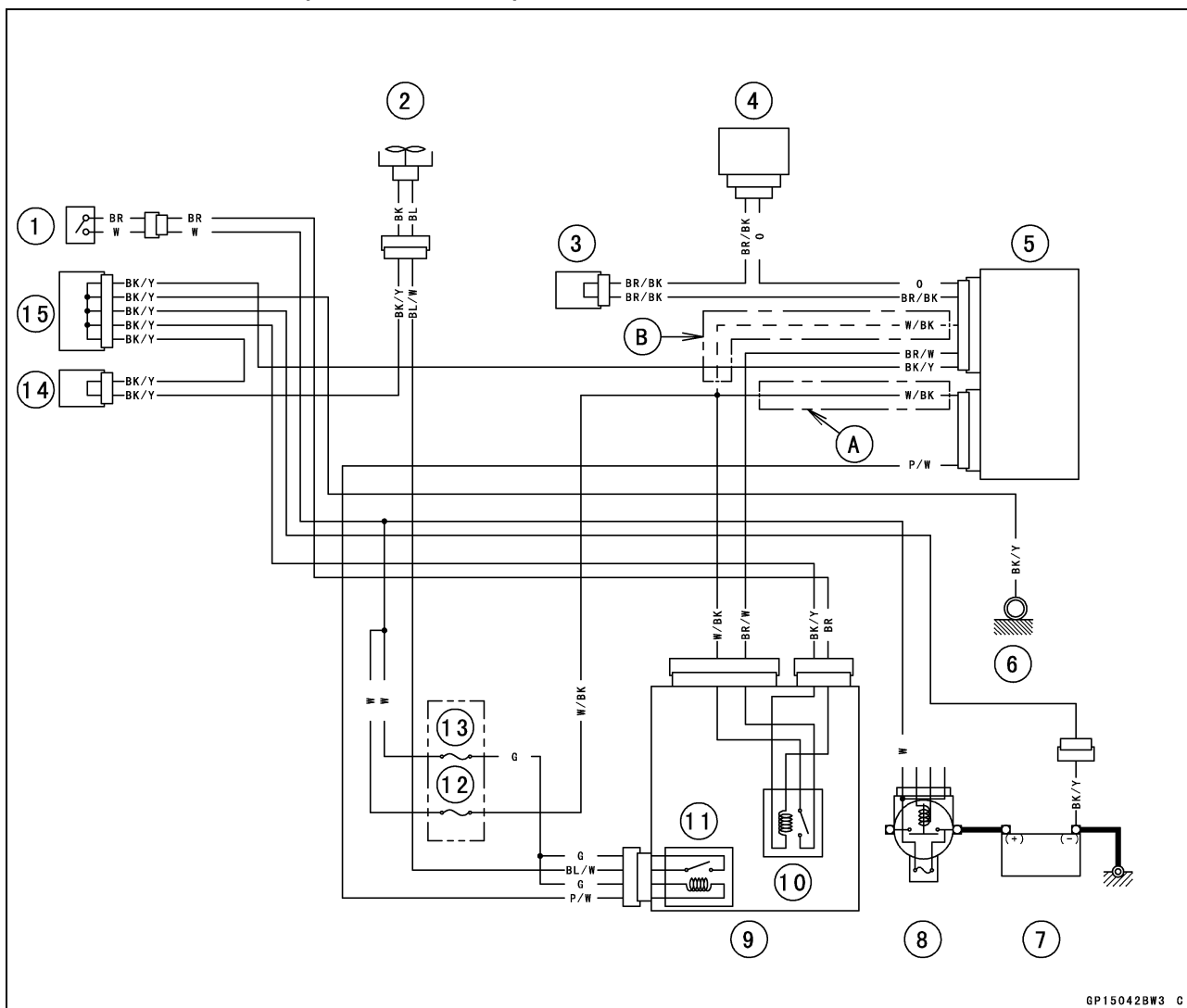

1. Ignition Switch
2. Radiator Fan
3. Joint Connector B
4. Water Temperature Sensor
5. ECU
6. Frame Ground
7. Battery
8. Main Fuse 30 A

9. Relay Box
10. ECU Main Relay
11. Radiator Fan Relay
12. ECU Fuse 15 A
13. Fan Fuse 15 A
14. Joint Connector A
15. Joint Connector C

A: Without Oxygen Sensor Equipped Models
 B: Oxygen Sensor Equipped Models

Radiator Fan System

Radiator Fan Relay Circuit (VN900C9 ~)

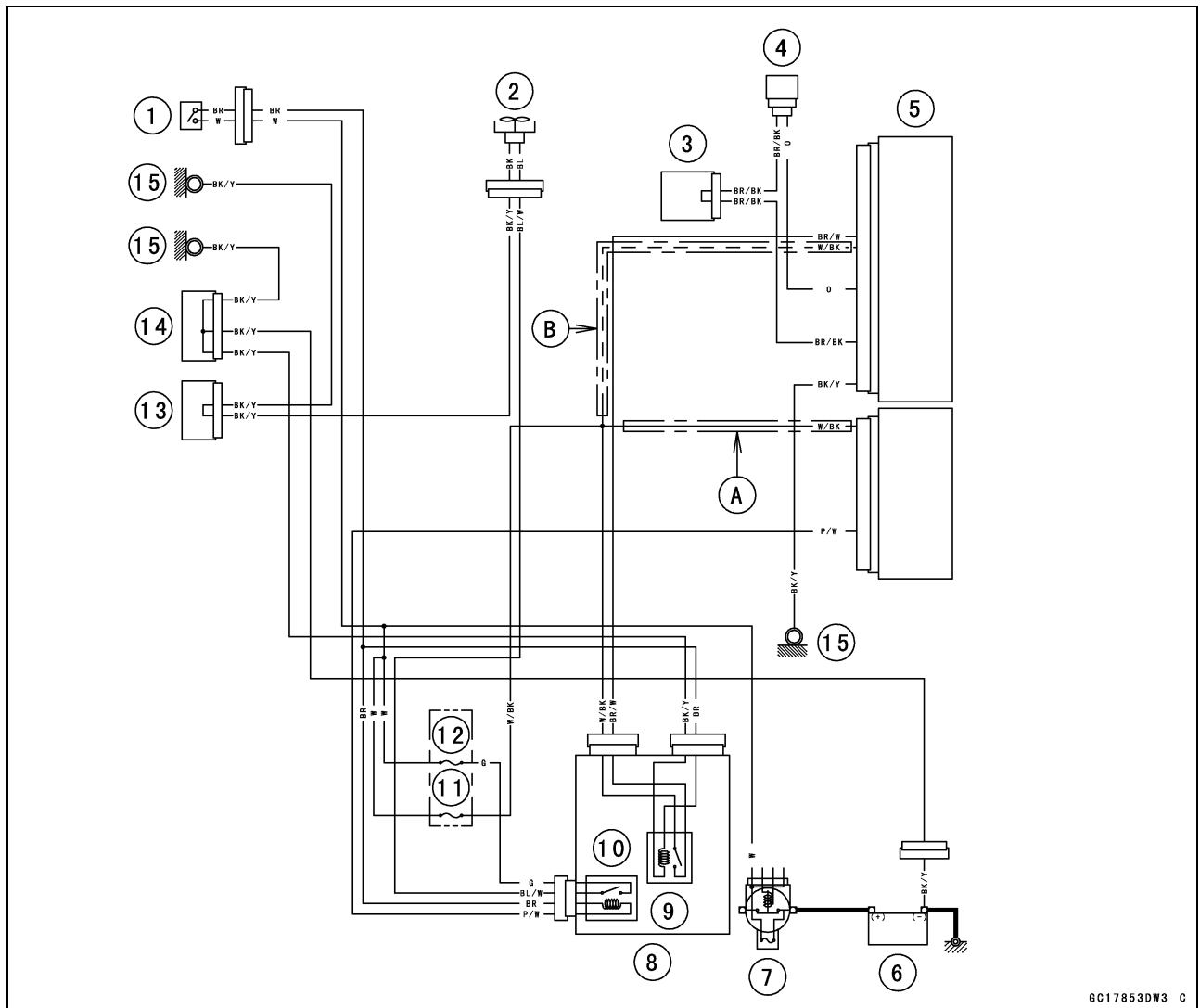

GC17853DW3 C

1. Ignition Switch
2. Radiator Fan
3. Joint Connector B
4. Water Temperature Sensor
5. ECU
6. Battery
7. Main Fuse 30 A
8. Relay Box
9. ECU Main Relay
10. Radiator Fan Relay
11. ECU Fuse 15 A
12. Fan Fuse 15 A
13. Joint Connector A
14. Joint Connector C
15. Frame Ground

A: Without Oxygen Sensor Equipped Models

B: Oxygen Sensor Equipped Models

16-82 ELECTRICAL SYSTEM

Meter Unit

Meter Unit Removal

- Remove the bolt [A], and lift up the tail of the cover [B].
- Push the cover forward a little, and remove the meter cover.



- Remove the meter unit [A].
- Pull out the meter unit end from the pin [B] on the fuel tank, and then pull out the front of the meter unit from the pins [C].
- Slide the dust cover [D] out, and disconnect the connector.

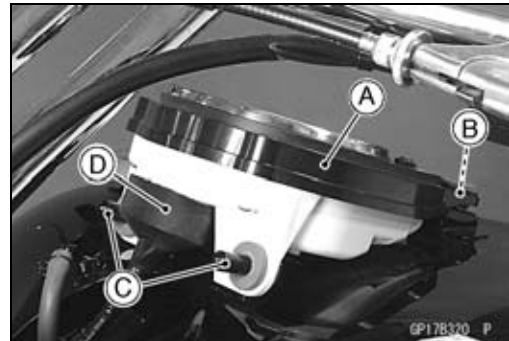

NOTICE

Never drop the meter unit, especially on a hard surface. Such a shock to the unit can damage it. Place the meter unit so that the face is up. If the meter unit is left upside down or sideways for any length of time, it will malfunction.

Meter Unit Installation

- Confirm that the rubber dampers [A] are in the meter unit.
- Connect the connector [B] and slide the dust cover [C] in.
- Be sure to put the holes onto the pins on the fuel tank.
- Install the meter cover, and tighten the bolt.

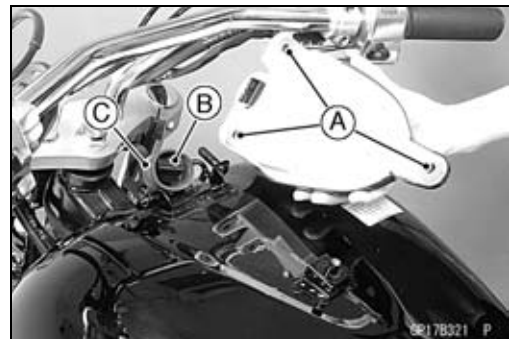

Meter Unit Disassembly

- Remove:
 - Meter Unit (see Meter Unit Removal)
 - Rear Rubber Damper [A]
 - Screws [B]
 - Upper Meter Cover [C]

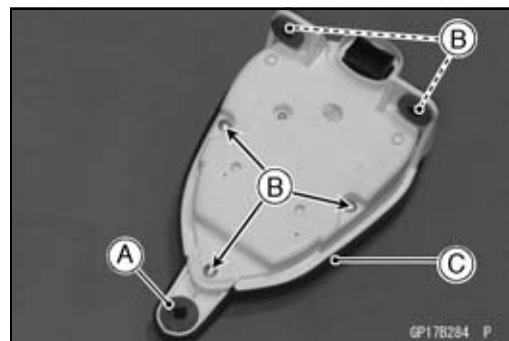

Meter Unit

- Remove the screw [A] on the lower meter cover to free the speedometer.

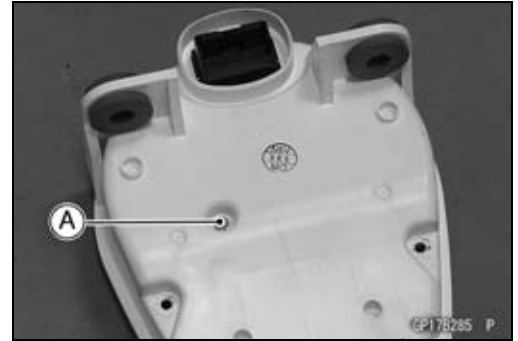

- Remove the screw [A] on the indicator panel to remove the panel.

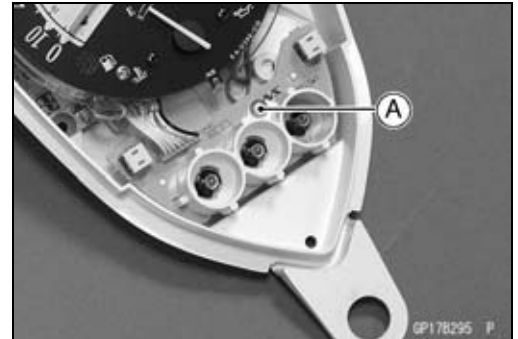

- Lifting the speedometer [A] with the indicator panel [B] attached, pull out the FI indicator light (LED) [C] and oil pressure warning light (LED) [D] from the lower meter cover [E].

NOTE

- The water temperature warning light (LED), oil pressure warning light (LED) and FI indicator light (LED) can not be exchanged.

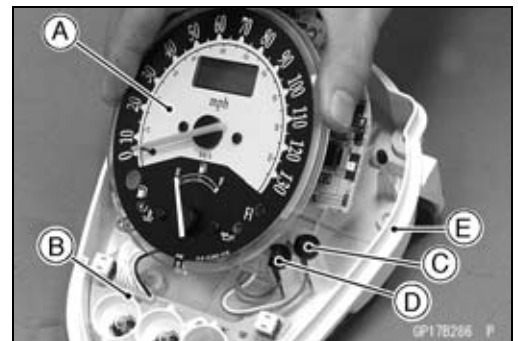

- Disconnect the connector [A].

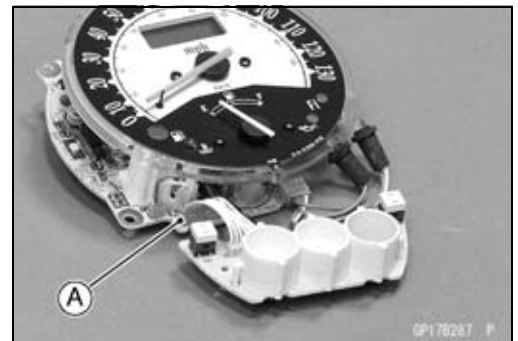

- Turn out the socket [A] counterclockwise.
- These sockets are for the high beam indicator light, turn signal indicator light and neutral indicator light.

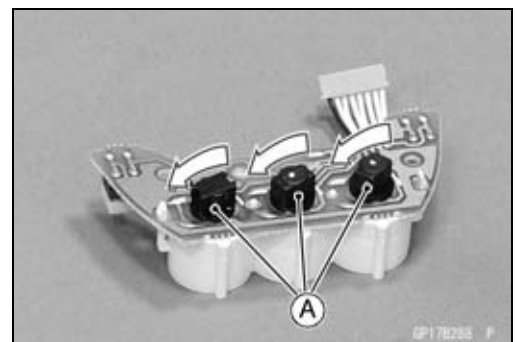

16-84 ELECTRICAL SYSTEM

Meter Unit

- Remove the wedge-base type bulb [A] by pulling the bulb straight out of the socket [B].

NOTICE

Do not turn the bulb. Pull the bulb out to prevent damage to the bulb. Do not use bulb rated for other than voltage or wattage specified in the wiring diagram.

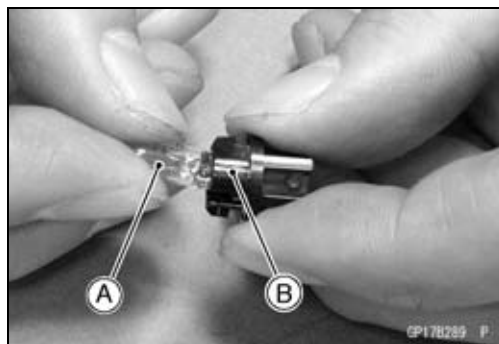

Meter Unit Assembly

- Connect the connector of the indicator panel to the speedometer.
- Put in the oil pressure warning light (LED) [A] and FI indicator light (LED) [B] to the lower meter cover.
Oil Pressure Warning Light (LED): Orange Lead and Green Lead
FI Indicator Light (LED) : Red Lead and White Lead

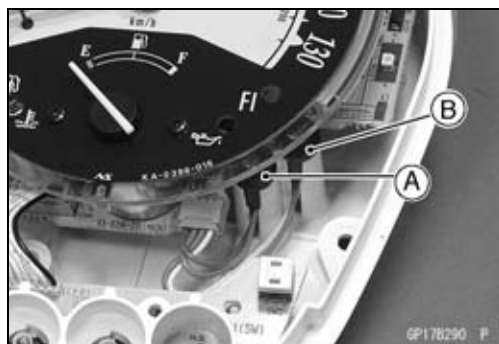

- Fit the speedometer and indicator panel onto the lower meter cover.
- Put the holes [A] onto the projections [B] of the lower meter cover.
- Tighten the screws.
- Install the upper meter cover, and tighten the screws.

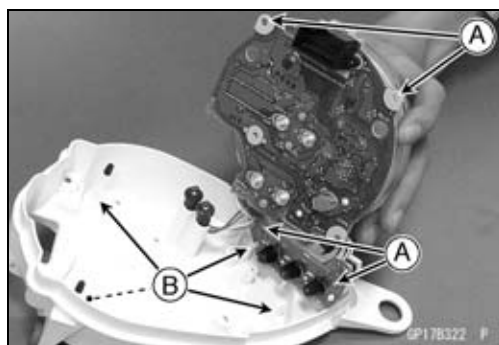

Meter Unit Inspection

Mode Selection and Reset Button Checks

- When the ignition switch is turned ON, all the LCD segments (the letters and numbers of the liquid crystal display) [A] appear for 3 seconds on the meter.
- If they do not appear, check the LCD segments.



- Check that the display [A] changes to the CLOCK, ODO, and TRIP display each time the mode select button [B] is pushed.

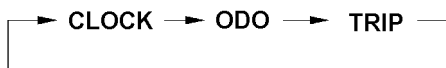

- If the display doesn't change in the order specified, replace the speedometer assembly.

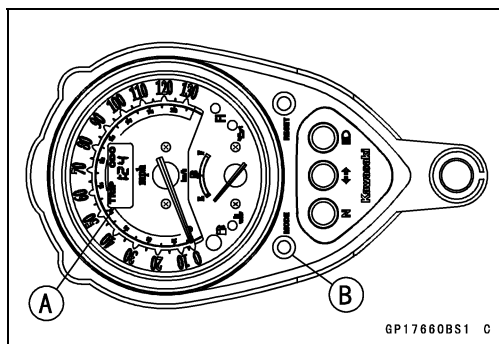

Meter Unit

- Push the mode select button to TRIP and push the reset button [A] more than 2 seconds. The display shows "0.0".
- ★ If the display doesn't show "0.0", replace the speedometer assembly.

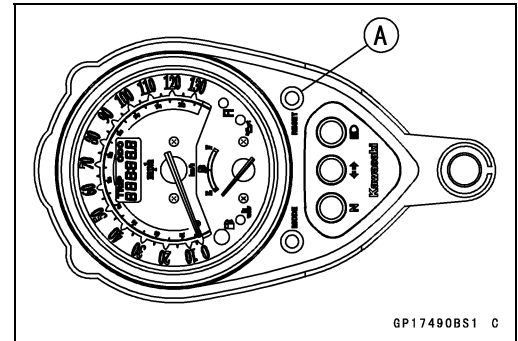

- Push the mode select button to CLOCK.
- Push the reset button [A] more than 2 seconds, then the display turns to the HOUR/MINUTE mode [B].
- In the HOUR/MINUTE mode, the numbers flash on the display.
- Check that the flashing number changes to the HOUR or MINUTE display each time the reset button is pushed.

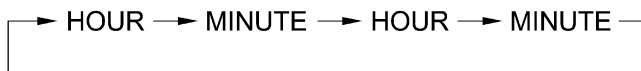

- Check that the time can be set in this mode.
- ★ If the time cannot be set, replace the speedometer assembly.

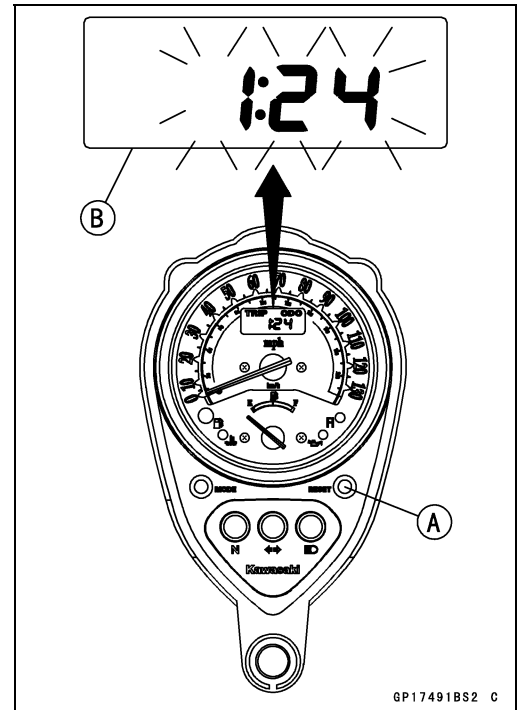

Clock Setting

- In the HOUR/MINUTE setting mode, push the reset button [A] again to effect the HOUR setting mode.
- The hour display flashes [B] on the display.
- Push the mode select button to set the hour.



- In the HOUR setting mode, push the reset button [A] once to effect the MINUTE setting mode.
- The minute display flashes [B] on the display.
- Push the mode select button to set the minute.



16-86 ELECTRICAL SYSTEM

Meter Unit

- Set the minute, push the reset button [A] to return to the HOUR/MINUTE setting mode.
- Push the mode select button [B] to complete the time setting process.
- The clock starts counting the seconds as soon as the mode select button is pushed.



LCD Segment Inspection

- Remove the meter unit [A] (see Meter Unit Removal).

NOTICE

Do not drop the meter unit. Such a shock to the meter unit can damage it. Place the meter facing up. If a meter is left upside down or sideways for any length of time, it will malfunction.

- [1] Neutral Indicator Light (-)
- [2] FI Indicator Light (LED) (-)
- [3] Oil Temperature Warning Light (LED) (-)
- [4] Water Temperature Warning Light (LED) (-)
- [5] Unused
- [6] Unused
- [7] Unused
- [8] Unused
- [9] Unused
- [10] Speedometer Illumination Light (LED) (+)
- [11] Battery (+)
- [12] Ignition
- [13] Battery (-)
- [14] Unused
- [15] Speed Sensor Signal
- [16] Fuel Gauge Signal
- [17] Left Turn Signal Indicator Light (+)
- [18] Right Turn Signal Indicator Light (+)
- [19] Fuel Level Warning Light (-)
- [20] High Beam Indicator Light (+)

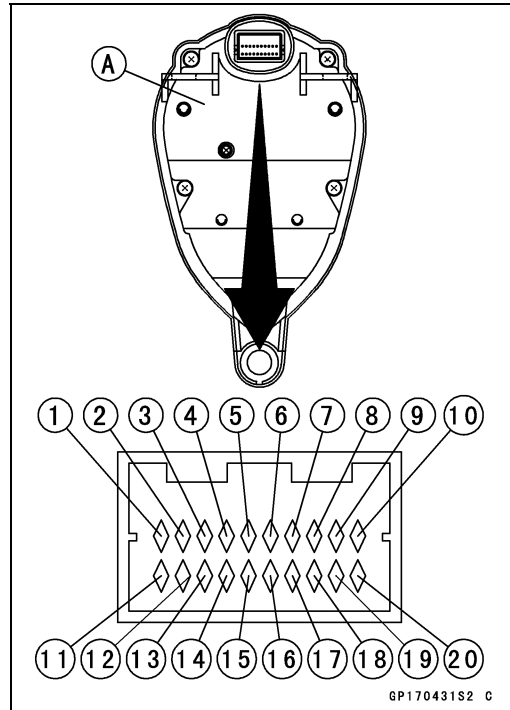

NOTICE

Do not short each terminals. When inspecting the meter unit be sure to connect each connections.

Meter Unit

- Using the auxiliary wires, connect a 12 V battery to the meter unit connector terminals.

Connections

Battery Positive Terminal (+) → Terminal [11]

Battery Negative Terminal (-) → Terminal [13]

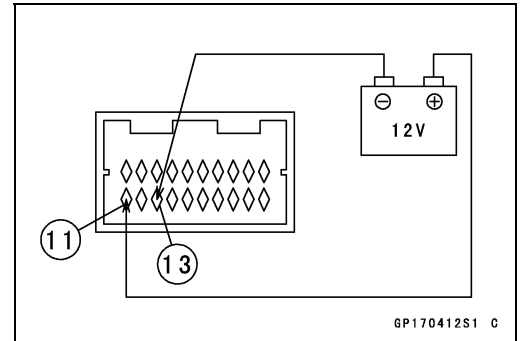

- Using the auxiliary wires, connect the battery positive wire to terminal [12].
- Verify that all the LCD segments (the letters and numbers of the liquid crystal display) to appear for 3 seconds. Then the clock or meters operates normally depending on the mode selected.
- Check that disconnecting the terminal [12] causes all the LCD segments to become unlit.
- ★ If there is any problem, replace the speedometer assembly.

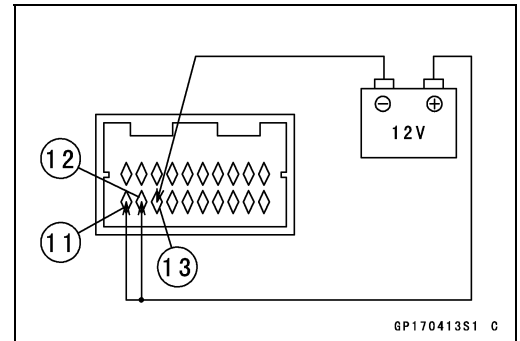

Speedometer Inspection

- If an oscillator is unavailable, check the speedometer as follows.
 - Install the meter unit.
 - Raise the rear wheel off the ground with jack (see Rear Wheel Removal in the Wheels/Tires chapter).
 - Turn the ignition switch ON.
 - Turn the rear wheel by hand to see if the speedometer shows the vehicle speed [A] that corresponds to the wheel rotation.
- ★ If it does not show properly, inspect the speed sensor and power to the speed sensor.
- ★ If the speed sensor and power to the speed sensor are normal, replace the meter assembly.



16-88 ELECTRICAL SYSTEM

Meter Unit

- If an oscillator is available, check the speedometer as follows.
- Connect the terminals in the same way as in the LCD segment inspection.
- Connect the oscillator [A] to the terminal [15]. The vehicle speed that corresponds to the input frequency will be displayed when a short wave form such as the one shown in the diagram is input.

Example:

An input frequency of 720 Hz will display about 60 mph.

An input frequency of 450 Hz will display about 60 km/h.

- ★ If the meter does not function correctly, replace the speedometer assembly.

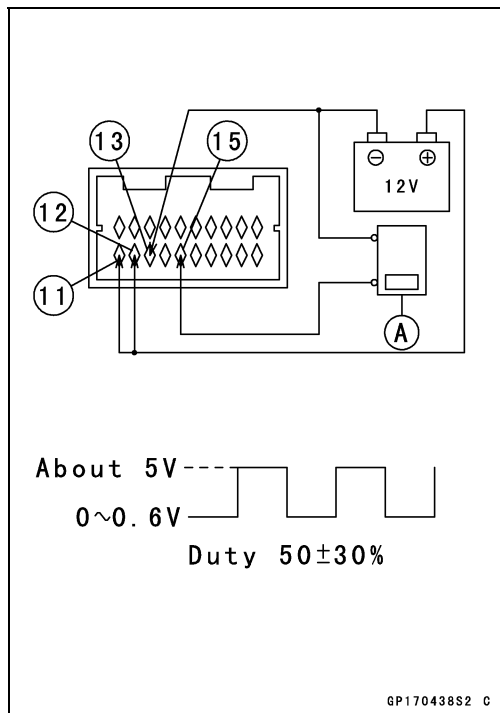

ODO Meter Inspection

- Turn the display [A] into ODO.
- During the speedometer inspection with an oscillator, verify that the odometer reading increases.
- ★ If it does not increase, replace the speedometer assembly.

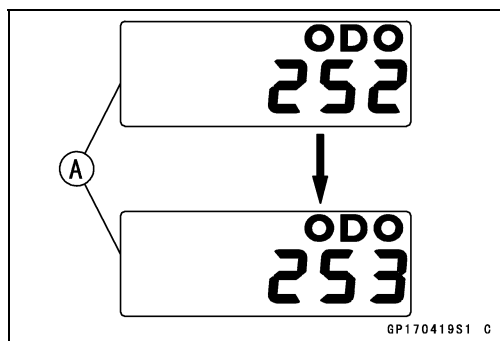

TRIP Meter Inspection

- Turn the display [A] into TRIP.
- During the speedometer inspection with an oscillator, verify that the trip meter reading increases.
- Stop the short wave form, press the reset button more than 2 seconds and check that the display shows "0.0".
- ★ If there are any problems, replace the speedometer assembly.

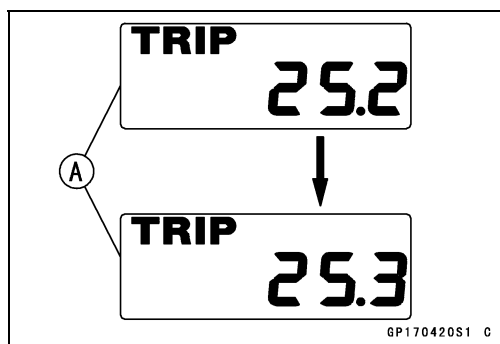

Meter Unit

Fuel Level Gauge Inspection

- Connect the terminals in the same way as in the LCD segment inspection.
- Connect a variable rheostat [A] to the terminal [16] and battery negative wire as shown in the figure.
- Check that the position of the gauge pointer matches the resistance value of the variable rheostat.

| Resistance (Ω) | Position of Gauge Pointer |
|-------------------------|---------------------------|
| 90 | E [B] |
| 38 | 1/2 |
| 10 | F [C] |

Resistance values are standard and they have tolerance.

★ If this indicator function does not work, replace the speedometer assembly.

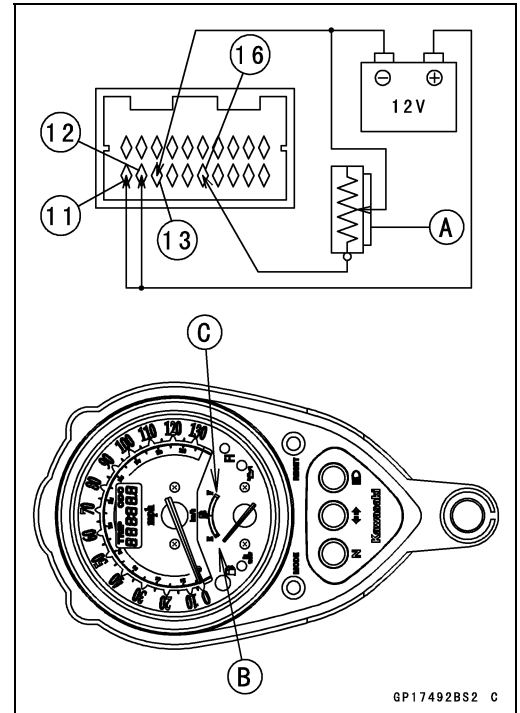

LED and Indicator Light Inspection

- Connect the 12 V battery to the meter terminals in the same way as in the LCD segment inspection.

FI Indicator Light (LED) Connections

Battery Negative Wire (-) to Terminal [2]

- Connect the terminal [2].
 - The FI indicator light (LED) lights.
 - Disconnect the terminal [2].
 - The FI indicator light (LED) disappears.
- ★ If there is any problem, replace the speedometer assembly.

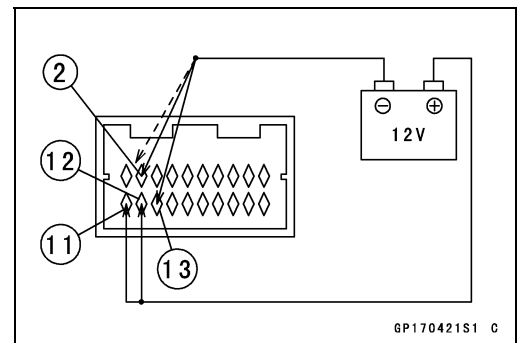

Oil Pressure Warning Light (LED) Connections

Battery Negative Wire (-) to Terminal [3]

- Connect the terminal [3].
 - The oil pressure warning light (LED) lights.
 - Disconnect the terminal [3].
 - The oil pressure warning light (LED) disappears.
- ★ If there is any problem, replace the speedometer assembly.

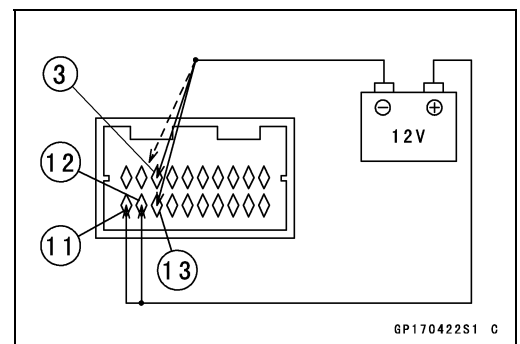

16-90 ELECTRICAL SYSTEM

Meter Unit

Water Temperature Warning Light (LED) Connections

Battery Negative Wire (-) to Terminal [4]

- Connect the terminal [4].
- The water temperature warning light (LED) lights.
- Disconnect the terminal [4].
- The water temperature warning light (LED) disappears.
- ★ If there is any problem, replace the speedometer assembly.

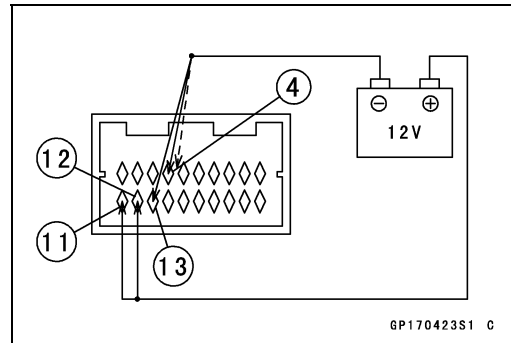

GP170423S1 C

Fuel Level Warning Light Connections

Battery Negative Wire (-) to Terminal [19]

- Connect the terminal [19].
- The fuel level warning light lights.
- Disconnect the terminal [19].
- The fuel level warning light disappears.
- ★ If there is any problem, inspect the bulb and bulb socket.
- ★ If they are normal, replace the speedometer assembly.

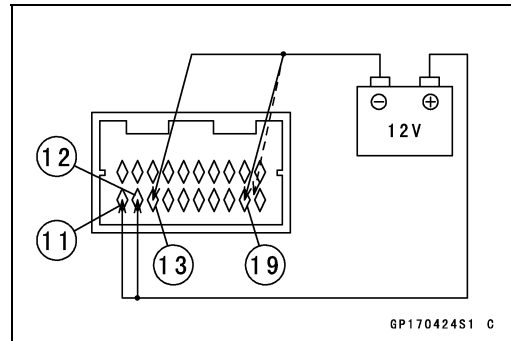

GP170424S1 C

Speedometer Illumination Light (LED) Connections

Battery Positive Wire (+) to Terminal [10]

- Connect the terminal [10].
- The Illumination light (LED) lights.
- Disconnect the terminal [10].
- The Illumination light (LED) disappears.
- ★ If there is any problem, replace the speedometer assembly.
- Be dotted the illumination lights (LED) in the speedometer. If the meter pointer or LCD segments are hard to reading because of the unilluminative, replace the speedometer assembly.

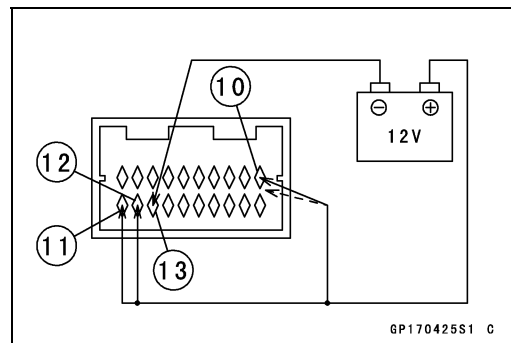

GP170425S1 C

Turn Signal Indicator Lights Connections

Battery Positive Wire (+) to Terminal [17] or [18]

- Connect the terminal [17] or [18].
- The turn signal indicator light lights.
- Disconnect the terminal [17] or [18].
- The signal indicator light disappears.

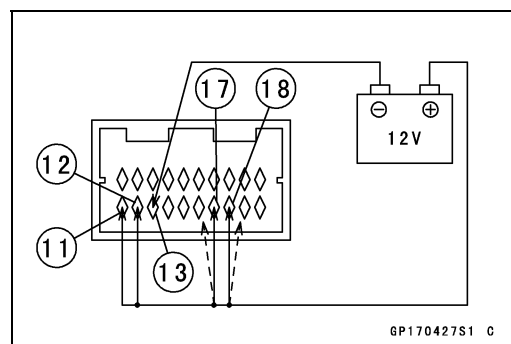

GP170427S1 C

Meter Unit

- ★ If there is any problem, inspect the bulb, bulb socket [A] and wiring of the indicator panel [B] for continuity.
- ★ If they are normal, replace the speedometer assembly.

Special Tool - Needle Adapter Set: 57001-1457

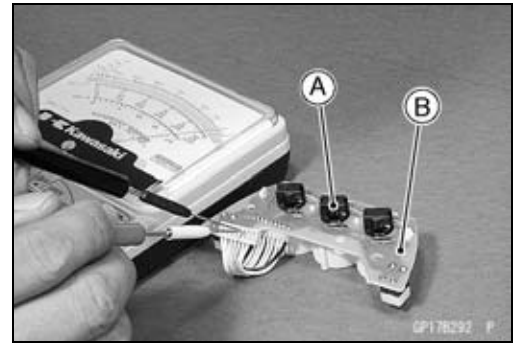

High Beam Indicator Light Connections Battery Positive Wire (+) to Terminal [20]

- Connect the terminal [20].
- The high beam indicator light lights.
- Disconnect the terminal [20].
- The turn signal indicator light disappears.

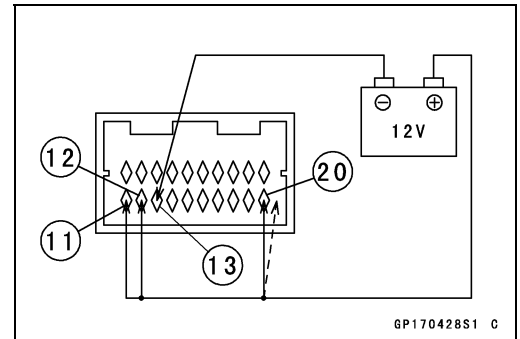

- ★ If there is any problem, inspect the bulb, bulb socket [A] and wiring of the indicator panel [B] for continuity.
- ★ If they are normal, replace the speedometer assembly.

Special Tool - Needle Adapter Set: 57001-1457

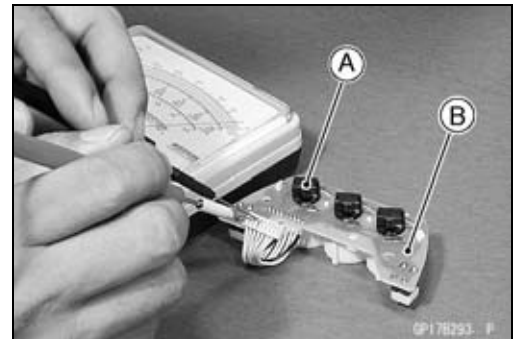

Neutral Indicator Light Connections Battery Negative Wire (-) to Terminal [1]

- Connect the terminal [1].
- The neutral indicator light lights.
- Disconnect the terminal [1].
- The neutral indicator light disappears.

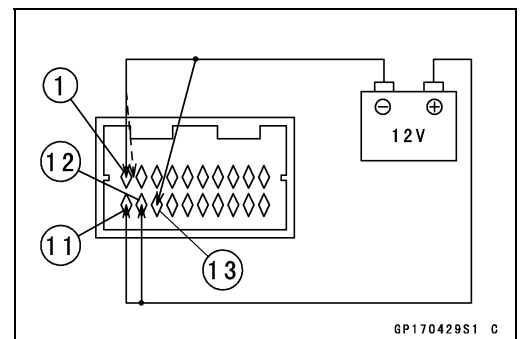

- ★ If there is any problem, inspect the bulb, bulb socket [A] and wiring of the indicator panel [B] for continuity.
- ★ If they are normal, replace the speedometer assembly.

Special Tool - Needle Adapter Set: 57001-1457

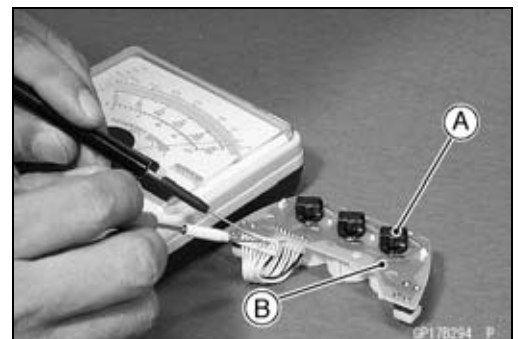

16-92 ELECTRICAL SYSTEM

Meter Unit

Meter Circuit (VN900C7 ~ C8)

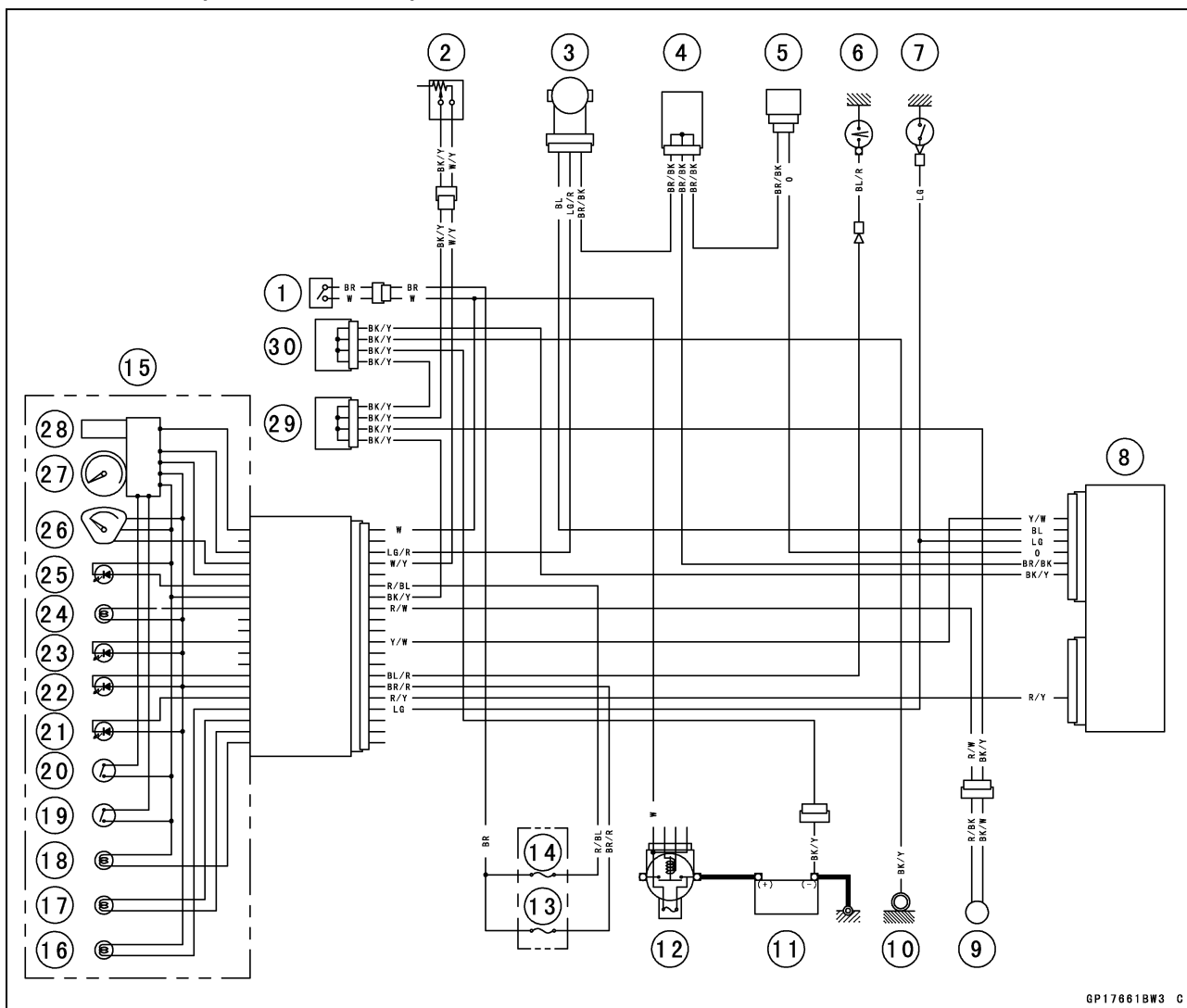

GP17661BW3 C

- | | |
|-----------------------------|---|
| 1. Ignition Switch | 16. Neutral Indicator Light |
| 2. Fuel Level Sensor | 17. Turn Signal Indicator Light |
| 3. Speed Sensor | 18. High Beam Indicator Light |
| 4. Joint Connector B | 19. Reset Button |
| 5. Water Temperature Sensor | 20. Mode Button |
| 6. Oil Pressure Switch | 21. FI Indicator Light (LED) |
| 7. Neutral Switch | 22. Oil Pressure Warning Indicator Light (LED) |
| 8. ECU | 23. Water Temperature Warning Indicator Light (LED) |
| 9. Fuel Reserve Switch | 24. Fuel Level Warning Indicator Light |
| 10. Frame Ground | 25. Illumination Light (LED) |
| 11. Battery | 26. Fuel Level Gauge |
| 12. Main Fuse 30 A | 27. Speedometer |
| 13. Ignition Fuse 10 A | 28. Odometer/Trip Meter /Clock Display |
| 14. Tail Light Fuse 10 A | 29. Joint Connector A |
| 15. Meter Unit | 30. Joint Connector C |

Meter Unit

Meter Circuit (VN900C9 ~)

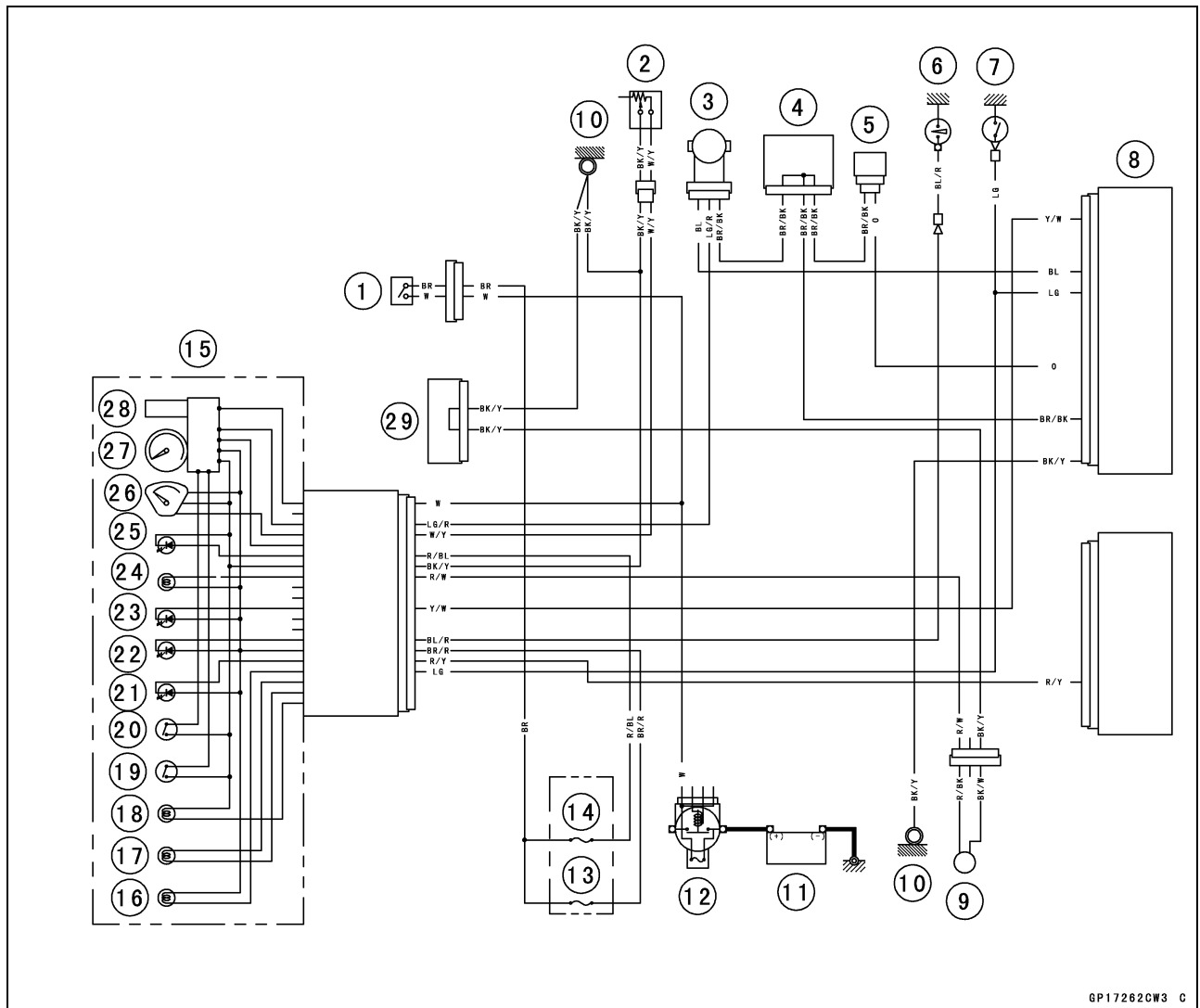

GP17262CW3 C

- | | |
|-----------------------------|---|
| 1. Ignition Switch | 16. Neutral Indicator Light |
| 2. Fuel Level Sensor | 17. Turn Signal Indicator Light |
| 3. Speed Sensor | 18. High Beam Indicator Light |
| 4. Joint Connector B | 19. Reset Button |
| 5. Water Temperature Sensor | 20. Mode Button |
| 6. Oil Pressure Switch | 21. FI Indicator Light (LED) |
| 7. Neutral Switch | 22. Oil Pressure Warning Indicator Light (LED) |
| 8. ECU | 23. Water Temperature Warning Indicator Light (LED) |
| 9. Fuel Reserve Switch | 24. Fuel Level Warning Indicator Light |
| 10. Frame Ground | 25. Illumination Light (LED) |
| 11. Battery | 26. Fuel Level Gauge |
| 12. Main Fuse 30 A | 27. Speedometer |
| 13. Ignition Fuse 10 A | 28. Odometer/Trip Meter /Clock Display |
| 14. Tail Light Fuse 10 A | 29. Joint Connector A |
| 15. Meter Unit | 30. Joint Connector C |

16-94 ELECTRICAL SYSTEM

Meter Unit

Fuel Gauge Operation Inspection

- Remove the fuel tank bolts (see Fuel Tank Removal in the Fuel System (DFI) chapter).
- Lift the fuel tank front part a little and pull the fuel gauge connector forward.
- Disconnect the fuel gauge connector.
- Prepare an auxiliary wire, and check the operation of the gauge.
- Open or short the fuel level sensor wires to check the fuel gauge operation.
 - Fuel Level Sensor Connector [A] (Fuel Tank Side)
 - Fuel Level Sensor Connector [B] (Main Harness Side)

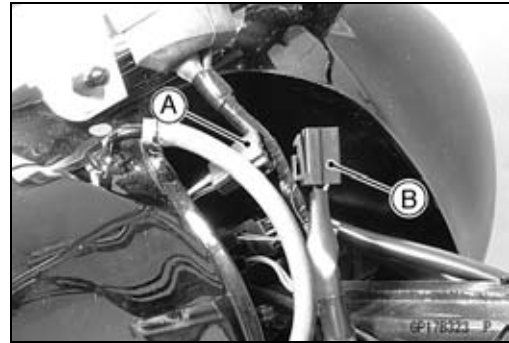

Fuel Gauge Operation Check

Ignition Switch Position: ON

Wire Location: Female 2-pin fuel gauge connector (disconnected)

Results: Gauge should read E when connector wires are opened.

Gauge should read F when connector wires are shorted.

- ★ If the gauge readings are correct, the fuel level sensor is bad (see Fuel Level Sensor Inspection). If these readings are not obtained, the trouble is with the gauge and/or wiring.
- Check the fuel gauge circuit wiring (see Wiring Inspection).
- ★ If all wiring and components other than the fuel gauge check out good, the gauge is defective. Replace the speedometer assembly.

Switches and Sensors

Brake Light Timing Inspection

- Refer to the Brake Light Switch Operation Inspection in the Periodic Maintenance chapter.

Brake Light Timing Adjustment

- Refer to the Brake Light Switch Operation Inspection in the Periodic Maintenance chapter.

Switch Inspection

- Using a digital meter, check to see that only the connections shown in the table have continuity (about zero ohms).
- For the switch housings and the ignition switch, refer to the tables in the Wiring Diagram.
- ★ If the switch has an open or short, repair it or replace it with a new one.

| Rear Brake Light Switch Connections | | |
|-------------------------------------|-----|-----|
| Color | BR | BL |
| When brake pedal is pushed down | ○ — | — ○ |
| When brake pedal is released | | |

| Sidestand Switch Connections | | |
|------------------------------|-----|-----|
| Color | BK | G |
| When sidestand is down | | |
| When sidestand is up | ○ — | — ○ |

| Neutral Switch Connections | | |
|-------------------------------------|--------------|--------|
| Color | SW. Terminal | Ground |
| When transmission is in neutral | ○ — | — ○ |
| When transmission is not in neutral | | |

| Oil Pressure Switch Connections * | | |
|-----------------------------------|--------------|--------|
| Color | SW. Terminal | Ground |
| When engine is stopped | ○ — | — ○ |
| When engine is running | | |

*: Engine lubrication system is in good condition.

16-96 ELECTRICAL SYSTEM

Switches and Sensors

Water Temperature Sensor Inspection

- Remove the water temperature sensor (see Water Temperature Sensor Removal/Installation in the Fuel System (DFI) chapter).
- Suspend the sensor [A] in a container of coolant so that the temperature-sensing projection [C] and threaded portion [C] are submerged.
- Suspend an accurate thermometer [B] with temperature-sensing projection located in almost the same depth.

NOTE

- *The sensor and thermometer must not touch the container side or bottom.*
- Place the container over a source of heat and gradually raise the temperature of the coolant while stirring the coolant gently.
- Using a digital meter, measure the internal resistance of the sensor.
- ★ If the a digital meter does not show the specified values, replace the sensor.

Water Temperature Sensor Resistance

| Temperature | Resistance (kΩ) |
|---------------|-----------------|
| -20°C (-4°F) | *18.80 ±2.37 |
| 0°C (32°F) | *(about 6.544) |
| 40°C (104°F) | 1.136 ±0.095 |
| 100°C (212°F) | 0.1553 ±0.0070 |

*: Reference Information

Speed Sensor Removal

- Remove:
 - Left Side Cover (see Left Side Cover Removal in the Frame chapter)
 - Reserve Tank (see Reserve Tank Removal in the Cooling System chapter)
 - Neutral Switch Terminal
 - Bolt [A]
 - Speed Sensor [B] with the connector [C] connected
- Disconnect the speed sensor connector.

Speed Sensor Installation

- Apply grease to the O-ring [A] on the speed sensor [B].
- Tighten:
 - Torque - Speed Sensor Mounting Bolt: 9.8 N·m (1.0 kgf·m, 87 in·lb)

Speed Sensor Inspection

- Refer to the Speed Sensor section in the Fuel System (DFI) chapter (see Speed Sensor section in the Fuel System (DFI) chapter).

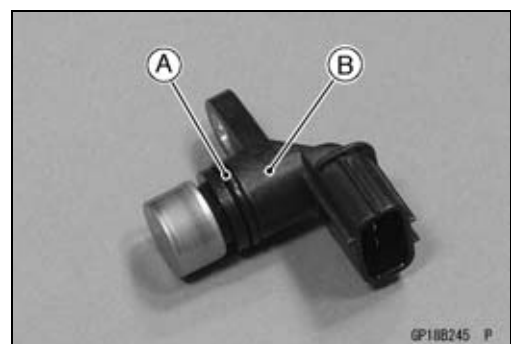
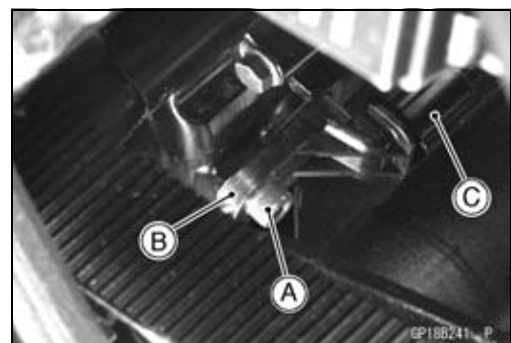
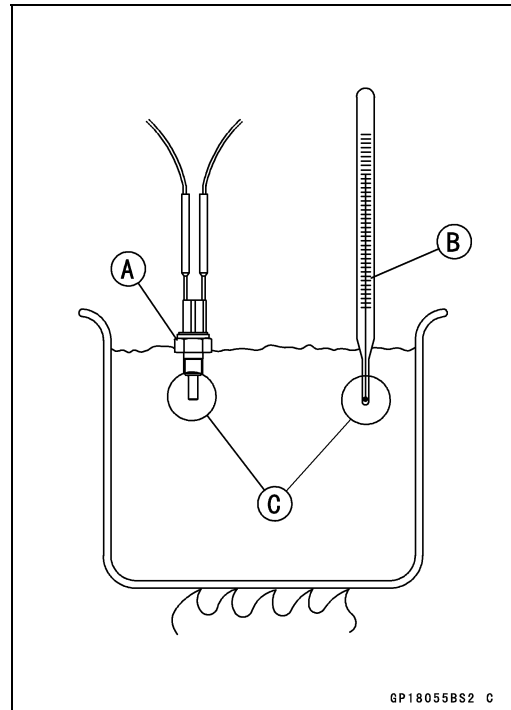

Switches and Sensors

Oxygen Sensor Removal (Oxygen Sensor Equipped Models)

- Remove the right side cover (see Right Side Cover Removal in the Frame chapter).
- Disconnect the oxygen sensor lead connectors [A].

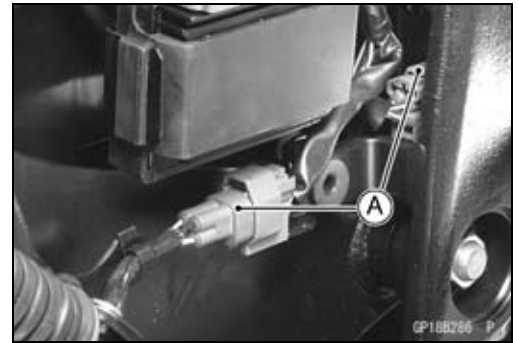

- Remove:
 - Muffler Covers [A] (see Muffler Removal in the Engine Top End chapter)
 - Oxygen Sensors [B]

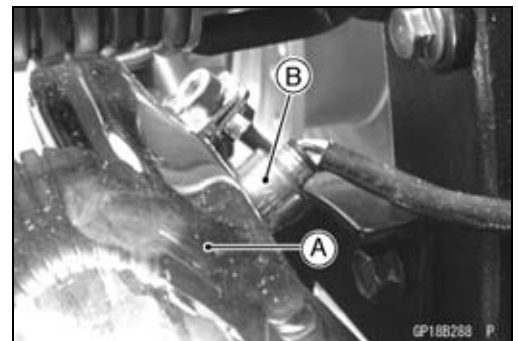
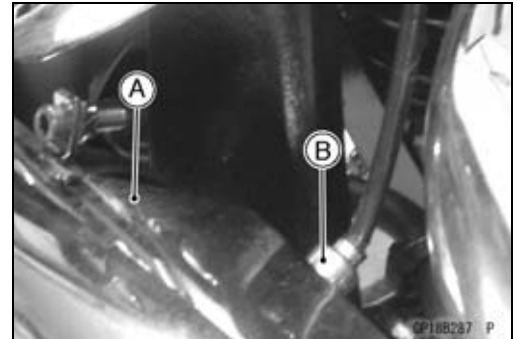

Oxygen Sensor Installation (Oxygen Sensor Equipped Models)

NOTICE

Never drop the Oxygen sensor [A], especially on a hard surface. Such a shock to the unit can damage it. Do not touch the sensing part [B] to prevent oil contact. Oil contamination from hands can reduce sensor performance.

VN900C7 ~ C8 [C]

VN900C9 ~ [D]

- Tighten:
 - Torque - Oxygen Sensors: 25 N·m (2.5 kgf·m, 18 ft·lb)
- Run the oxygen sensor leads correctly (see Cable, Wire, and Hose Routing section in the Appendix chapter).

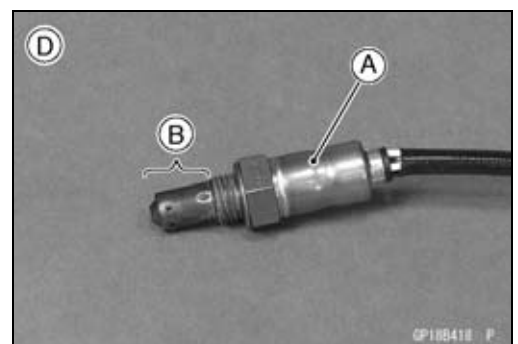
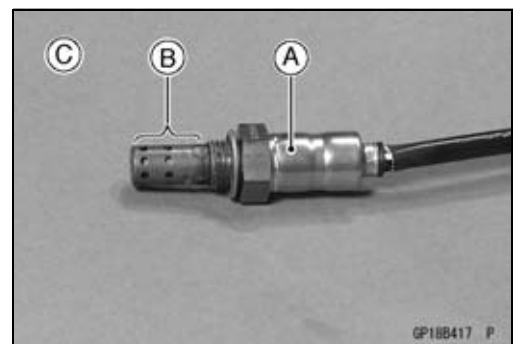

Oxygen Sensor Inspection (Oxygen Sensor Equipped Models)

- Refer to the Oxygen Sensor Inspection in the Fuel System (DFI) chapter.

16-98 ELECTRICAL SYSTEM

Switches and Sensors

Fuel Level Sensor Inspection

- Remove the fuel tank (see Fuel Tank Removal in the Fuel System (DFI) chapter).
- Open the clamps on the fuel tank.
- Remove:
 - Bolts [A]
 - Fuel Level Sensor [B]

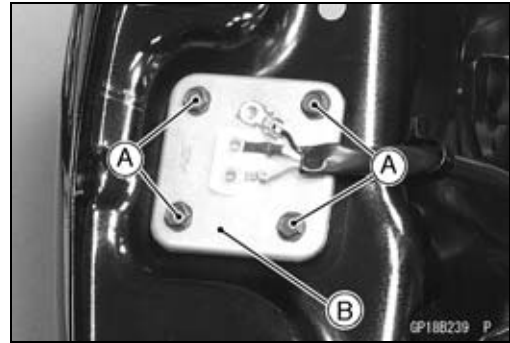

- Check that the float moves up and down smoothly without binding. It should go down under its own weight.
- ★ If the float does not move smoothly, replace the sensor.
 - Float in Full Position [A]
 - Float in Empty Position [B]
 - Float Arm Stoppers [C]

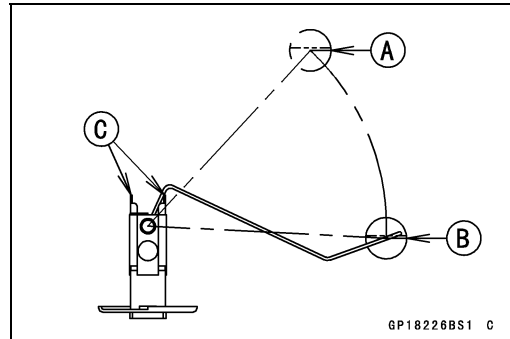

- Using a tester [A], measure the resistance across the terminals in the fuel level sensor lead connector [B].
 - Black/Yellow [C]
 - White/Yellow [D]
- ★ If the tester readings are not as specified, or do not change smoothly according as the float moves up and down, replace the sensor.

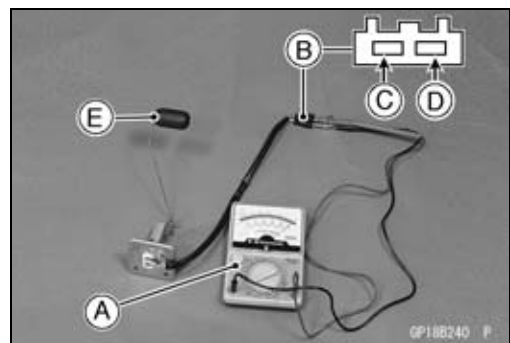

Fuel Level Sensor Resistance

Standard: Full position: 4 ~ 10 Ω

Empty position [E]: 90 ~ 100 Ω

- Install a new gasket [A] on the fuel tank [B] as shown in the figure.
 - Hollows [C]
 - Front Side [D]
- Apply a non-permanent locking agent to the threads of the fuel level sensor mounting bolts and tighten them.

Torque - Fuel Level Sensor Mounting Bolts: 6.9 N·m (0.70 kgf·m, 61 in·lb)

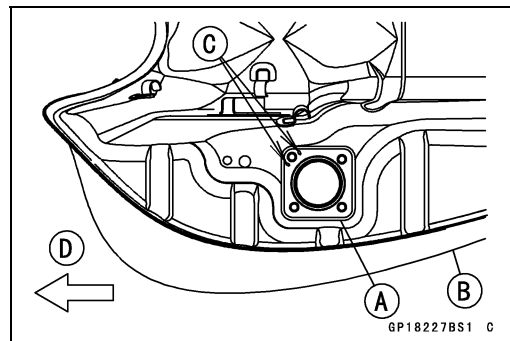

Switches and Sensors

Fuel Reserve Switch Inspection

- Fill the fuel tank with fuel.
- Close the fuel tank cap surely.
- Remove:
 - Ignition Coil Cover (see Ignition Coil Removal)
 - Fuel Pump Lead Connector [A]
- Connect the test light [B] (12 V 3.4 W bulb in a socket with leads) and the 12 V battery [C] to the fuel level sensor lead connector.

Connections:

Battery (+) → **12 V 3.4 W Bulb (One Side)**

12 V 3.4 W Bulb (Other Side) → **R/BK Lead Terminal [D]**

Battery (-) → **BK/W Lead Terminal [E]**

- ★ If the test light turn on, the reserve switch is defective. Replace the fuel pump.

- Remove the fuel pump (see Fuel Pump Removal in the Fuel System (DFI) chapter).
- Connect the test light (12 V 3.4 W bulb in a socket with leads) and the 12 V battery to the fuel pump lead connector as shown in the figure.
 - 12 V Battery [A]
 - Test Light [B]
 - Fuel Pump Lead Connector [C]
 - Fuel Reserve Switch [D]

- ★ If the test light doesn't light, replace the fuel pump.

NOTE

- It may take a long time to turn on the test light in case that the fuel reserve switch is inspected just after the fuel pump is removed. Leave the fuel reserve switch with leads for inspection connected for few minutes.

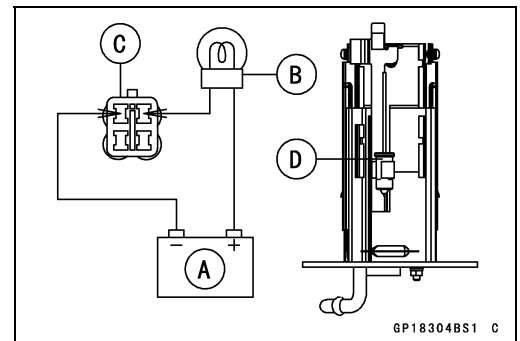
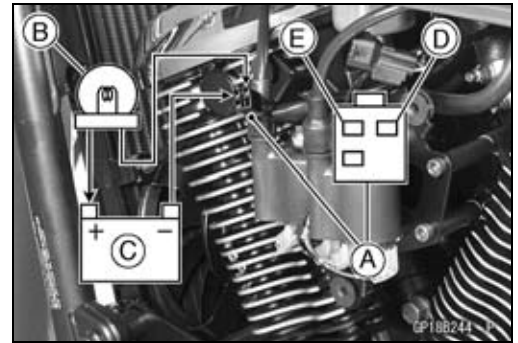

16-100 ELECTRICAL SYSTEM

Relay Box

The relay box [A] has relays and diodes. The relays and diodes can not be removed.

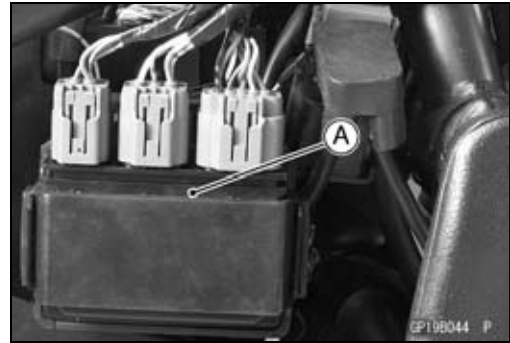

Relay Box Removal

- Remove the right side cover (see Right Side Cover Removal in the Frame chapter).
- Take out the relay box [A] and disconnect the connectors [B].

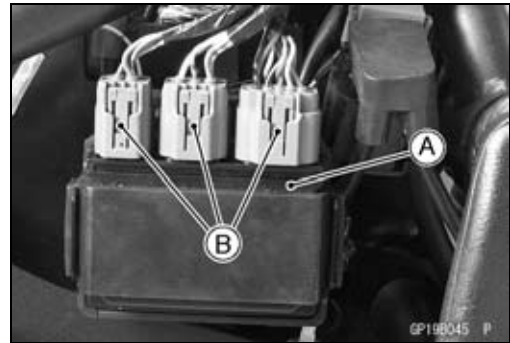

Relay Circuit Inspection

- Remove the relay box (see Relay Box Removal).
 - Check conductivity of the following numbered terminals by connecting a tester and one 12 V battery to the relay box as shown in the figure (see Relay Box Internal Circuit in this section).
- ★ If the tester does not read as specified, replace the relay box.

Relay Circuit Inspection (with the battery disconnected)

| | Tester Connection | Tester Reading (Ω) |
|-----------------------|-------------------|-----------------------------|
| Headlight Relay | 1-3 | ∞ |
| ECU Main Relay | 6-7 | ∞ |
| | 4-5 | Not ∞^* |
| Fuel Pump Relay | 7-8 | ∞ |
| | 9-10 | Not ∞^* |
| Starter Circuit Relay | 11-16 | ∞ |
| | 11-12 | ∞ |
| Fan Relay | 17-20 | ∞ |
| | 18-19 | Not ∞^* |

*: The actual reading varies with the hand tester used.

Relay Box

Relay Circuit Inspection (with the battery connected)

| | Battery Connection | | Tester Connection | Tester Reading (Ω) |
|-----------------|--------------------|-----|-------------------|-----------------------------|
| | (+) | (-) | | |
| ECU Main Relay | 2-11 | | 1-3 | 0 |
| | | 4-5 | 7-6 | 0 |
| Fuel Pump Relay | 9-10 | | 7-8 | 0 |
| Fan Relay | 18-19 | | 17-20 | 0 |

| | Battery Connection | | Tester Connection | Tester Reading (V) |
|-----------------------|--------------------|-----|-------------------|--------------------|
| | (+) | (-) | | |
| Starter Circuit Relay | 16-12 | | 11-12 | Battery Voltage |

(+): Apply positive lead.

(-): Apply negative lead.

Diode Circuit Inspection

- Remove the relay box (see Relay Box Removal).
- Check conductivity of the following pairs of terminals (see Relay Box Internal Circuit in this section).

Diode Circuit Inspection

| | |
|-------------------|---|
| Tester Connection | 1-11, 2-11, 12-13, 12-15, 12-16, 13-14, 13-15 |
|-------------------|---|

- ★ The resistance should be low in one direction and more than ten times as much in the other direction. If any diode shows low or high in both directions, the diode is defective and the relay box must be replaced.

NOTE

- *The actual meter reading varies with the meter or tester used and the individual diodes, but generally speaking, the lower reading should be from zero to one half the scale.*

16-102 ELECTRICAL SYSTEM

Relay Box

Relay Box Internal Circuit

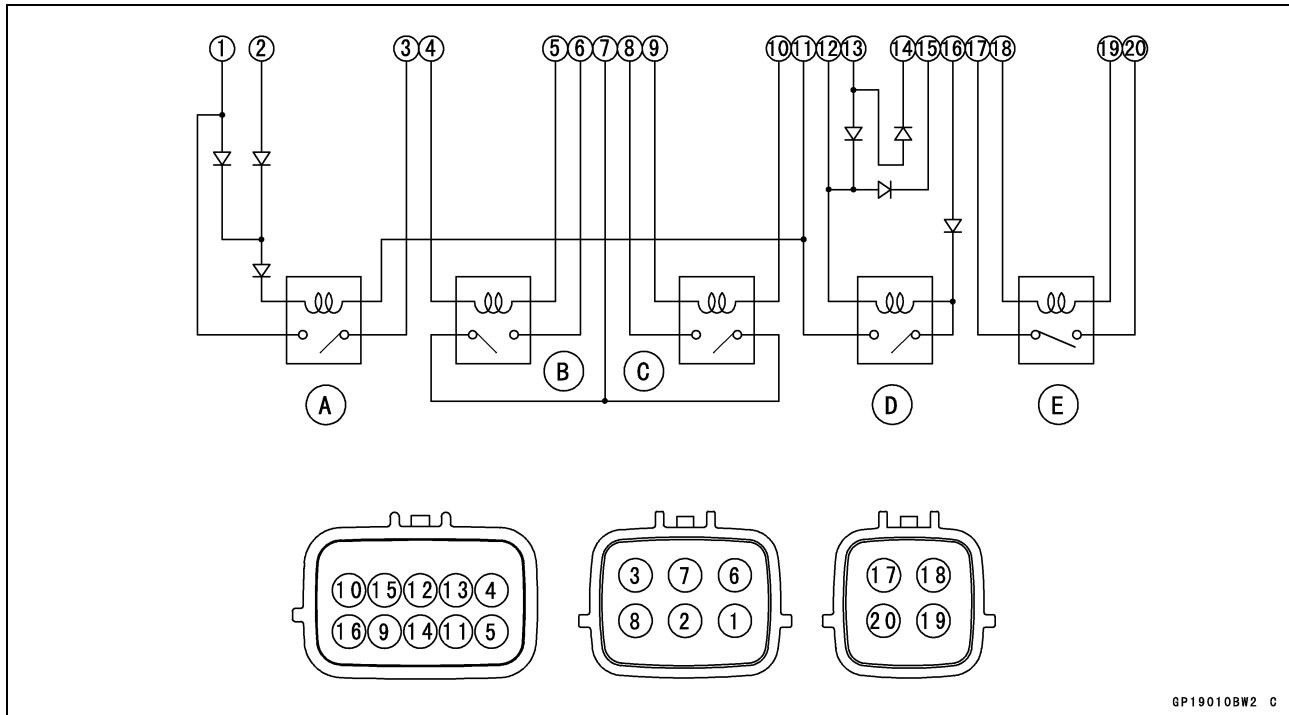

GP190108W2 C

- A: Headlight Relay
- B: ECU Main Relay
- C: Fuel Pump Relay
- D: Starter Circuit Relay
- E: Fan Relay

Fuse

30 A Main Fuse Removal

- Remove:
 - Right Side Cover (see Right Side Cover Removal in the Frame chapter)
 - Connector [A]
- Pull out the main fuse [B] from the starter relay with needle nose pliers.

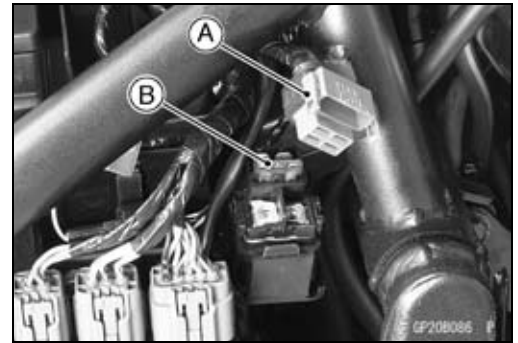

Fuse Box Fuse Removal

- Remove the left side cover (see Left Side Cover Removal in the Frame chapter).
- Unlock the hook [A] to lift up the lid [B].



- Pull the fuses [A] straight out of the fuse box with needle nose pliers.



15 A ECU Fuse Removal

- Remove the left side cover (see Left Side Cover Removal in the Frame chapter).
- Unlock the hook [A] to lift up the lid [B].



- Pull out the ECU fuse [A] from the fuse box.



16-104 ELECTRICAL SYSTEM

Fuse

Fuse Installation

- If a fuse fails during operation, inspect the electrical system to determine the cause, and then replace it with a new fuse of proper amperage.
- Install the fuse box fuses on the original position as specified on the lid.

Fuse Inspection

- Remove the fuse (see 30 A Main/Fuse Box/15 A ECU Fuse Removal).
- Inspect the fuse element.
- ★ If it is blown out, replace the fuse. Before replacing a blown fuse, always check the amperage in the affected circuit. If the amperage is equal to or greater than the fuse rating, check the wiring and related components for a short circuit.

Housing [A]

Fuse Element [B]

Terminals [C]

Blown Element [D]

NOTE

- If the engine is operated under the condition which the battery needs refreshing charge, a main fuse may blow out due to a mass current flows to the battery.

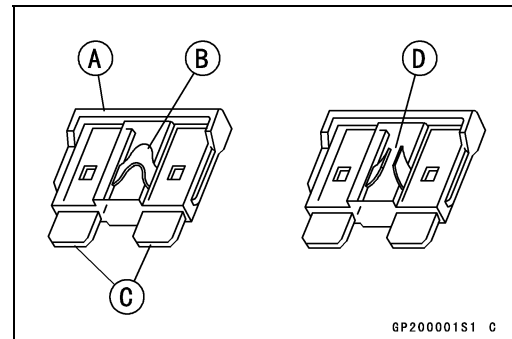

NOTICE

When replacing a fuse, be sure the new fuse matches the specified fuse rating for that circuit. Installation of a fuse with a higher rating may cause damage to wiring and components.

Appendix

Table of Contents

| | |
|-------------------------------------|-------|
| Cable, Wire, and Hose Routing | 17-2 |
| Troubleshooting Guide | 17-40 |

17-2 APPENDIX

Cable, Wire, and Hose Routing

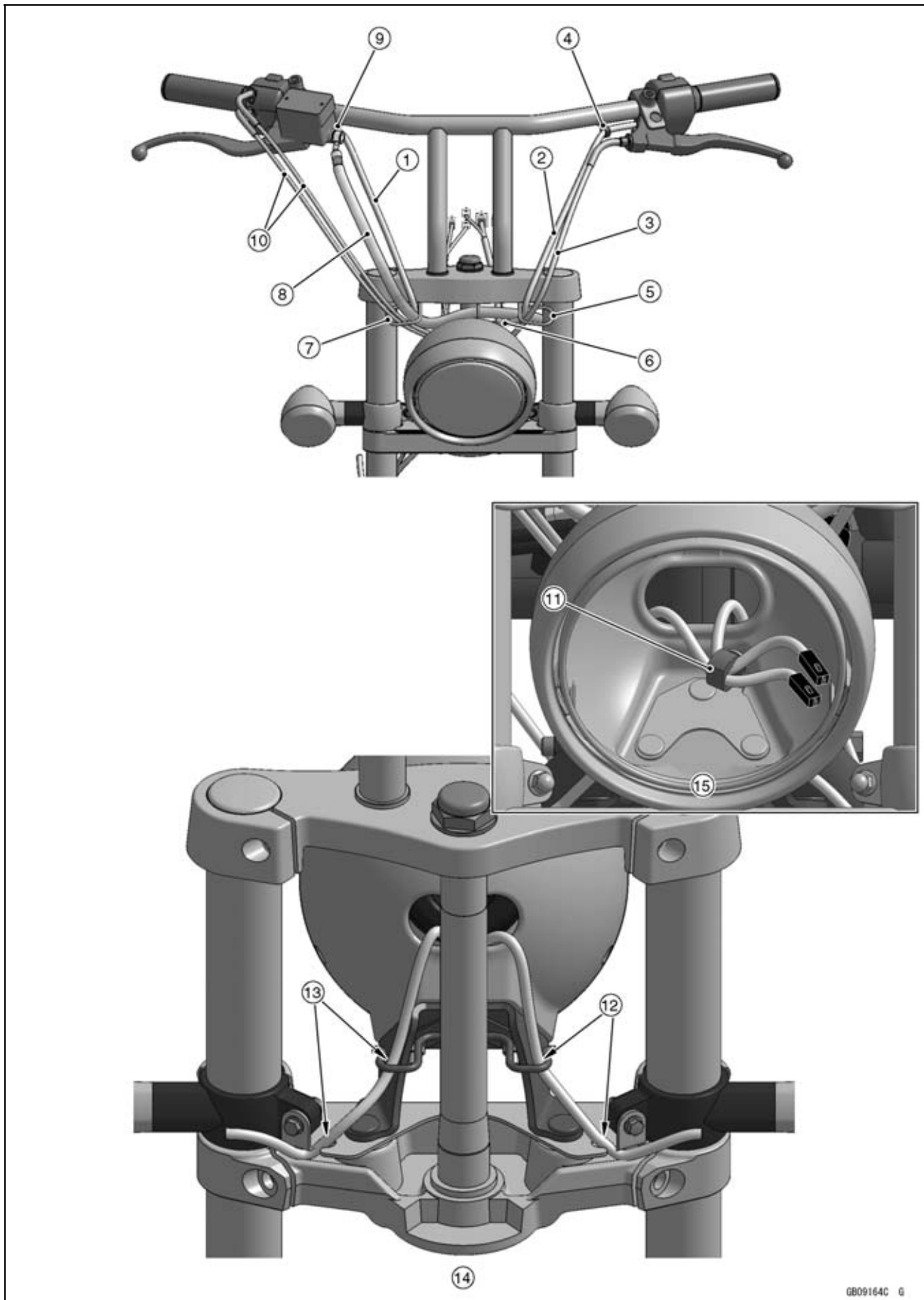

GB09164C G

Cable, Wire, and Hose Routing

1. Right Switch Housing Lead
2. Left Switch Housing Lead
3. Clutch Cable
4. Clamp the left switch housing lead.
5. Run the clutch cable and left switch housing lead through the clamp.
6. Run the clutch cable through the brake hose front side.
7. Run the throttle cables, brake hose and right switch housing lead through the clamp.
8. Brake Hose
9. Clamp the right switch housing lead.
10. Throttle Cables
11. Clamp the left and right turn signal lead.
12. Run the right turn signal lead to the notch of the bracket and clamp.
13. Run the left turn signal lead to the notch of the bracket and clamp.
14. Viewed from the rear
15. Inside of the Headlight Body

17-4 APPENDIX

Cable, Wire, and Hose Routing

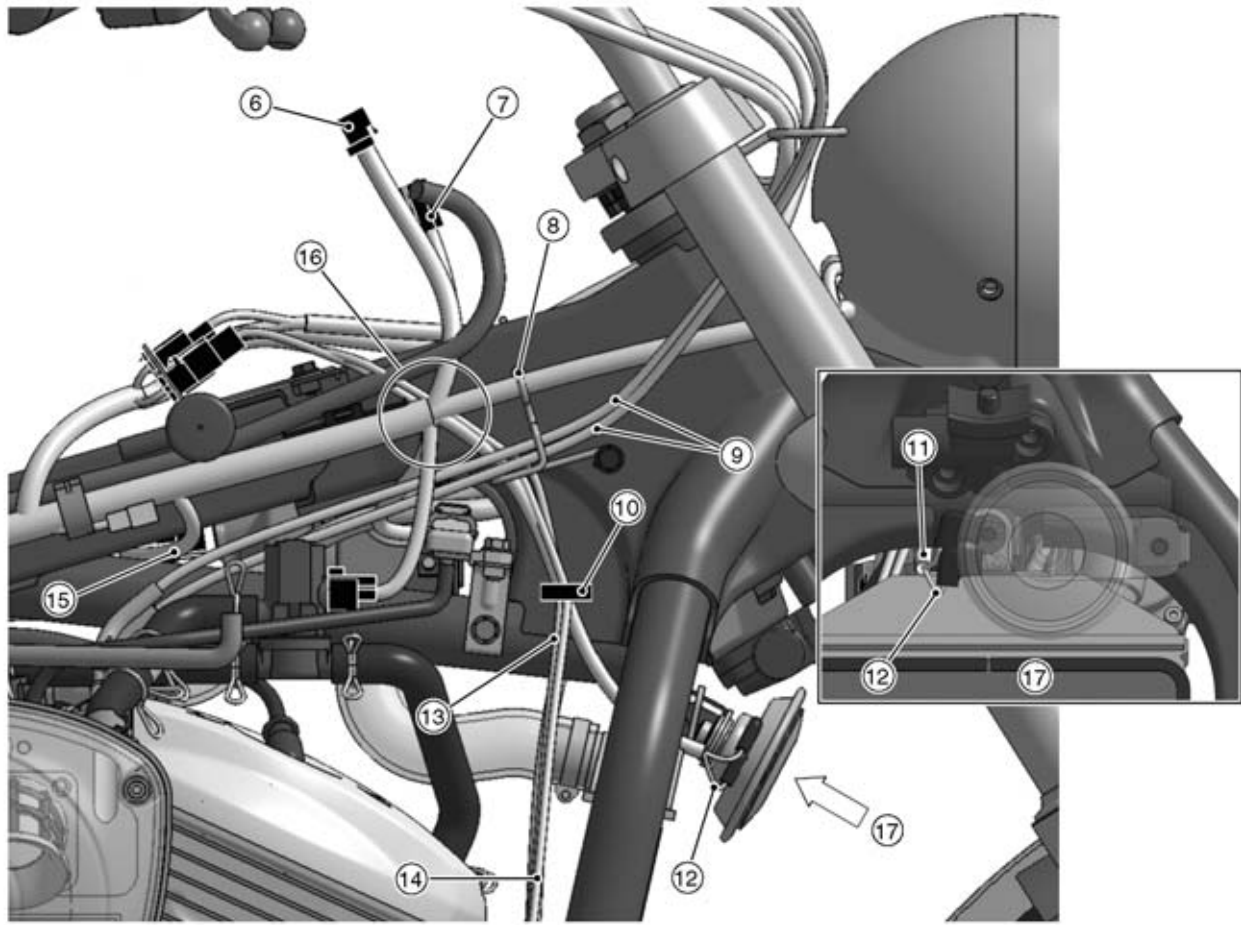
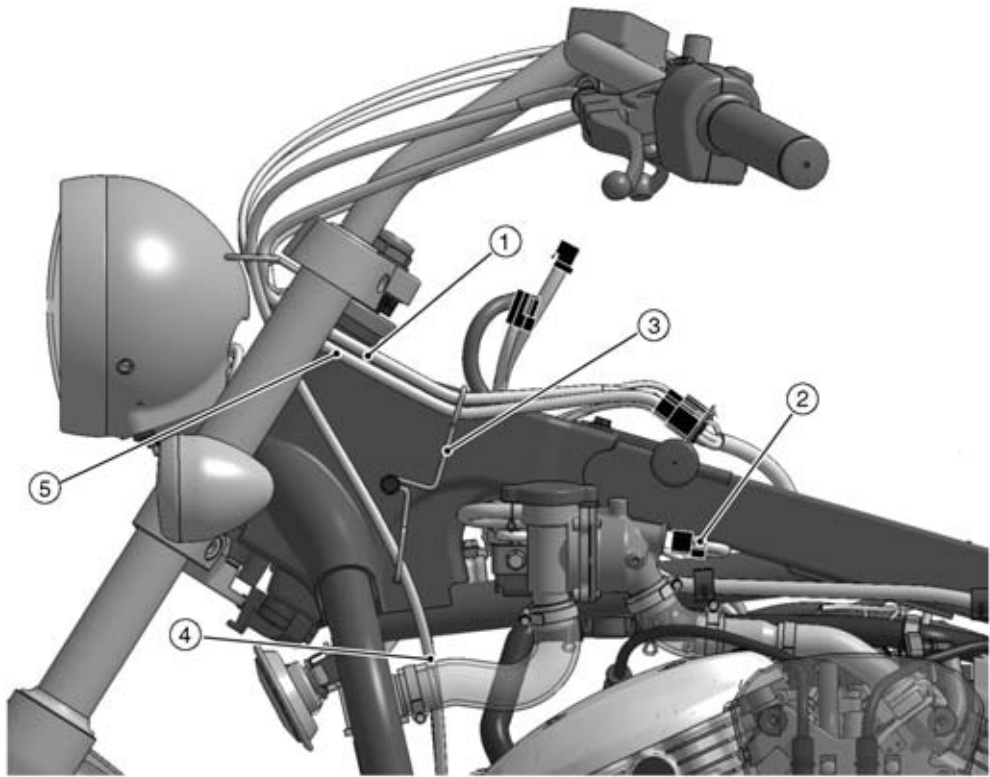

GB09165C G

Cable, Wire, and Hose Routing

1. Run the left switch housing lead under the brake hose.
2. Run the water temperature sensor lead connector over the reserve tank hose.
3. Clamp the left and right switch housing lead and clutch cable.
4. Run the clutch cable between the frame and radiator hose.
5. Right Switch Housing Lead
6. Meter Lead Connector
7. Fuel Level Sensor Lead Connector
8. Clamp (Run the throttle cables outside the each harness.)
9. Throttle Cables
10. Clamp the horn lead, rear brake light switch lead and radiator fan lead.
11. Run the horn lead through the right side of the radiator bracket.
12. Connect the horn terminals as shown in the figure.
13. Radiator Fan Lead
14. Rear Brake Light Switch Lead
15. Water Temperature Sensor Lead (To Left Side)
16. Run the rear brake light switch lead and radiator fan lead inside the main harness.
17. Viewed from the front

17-6 APPENDIX

Cable, Wire, and Hose Routing

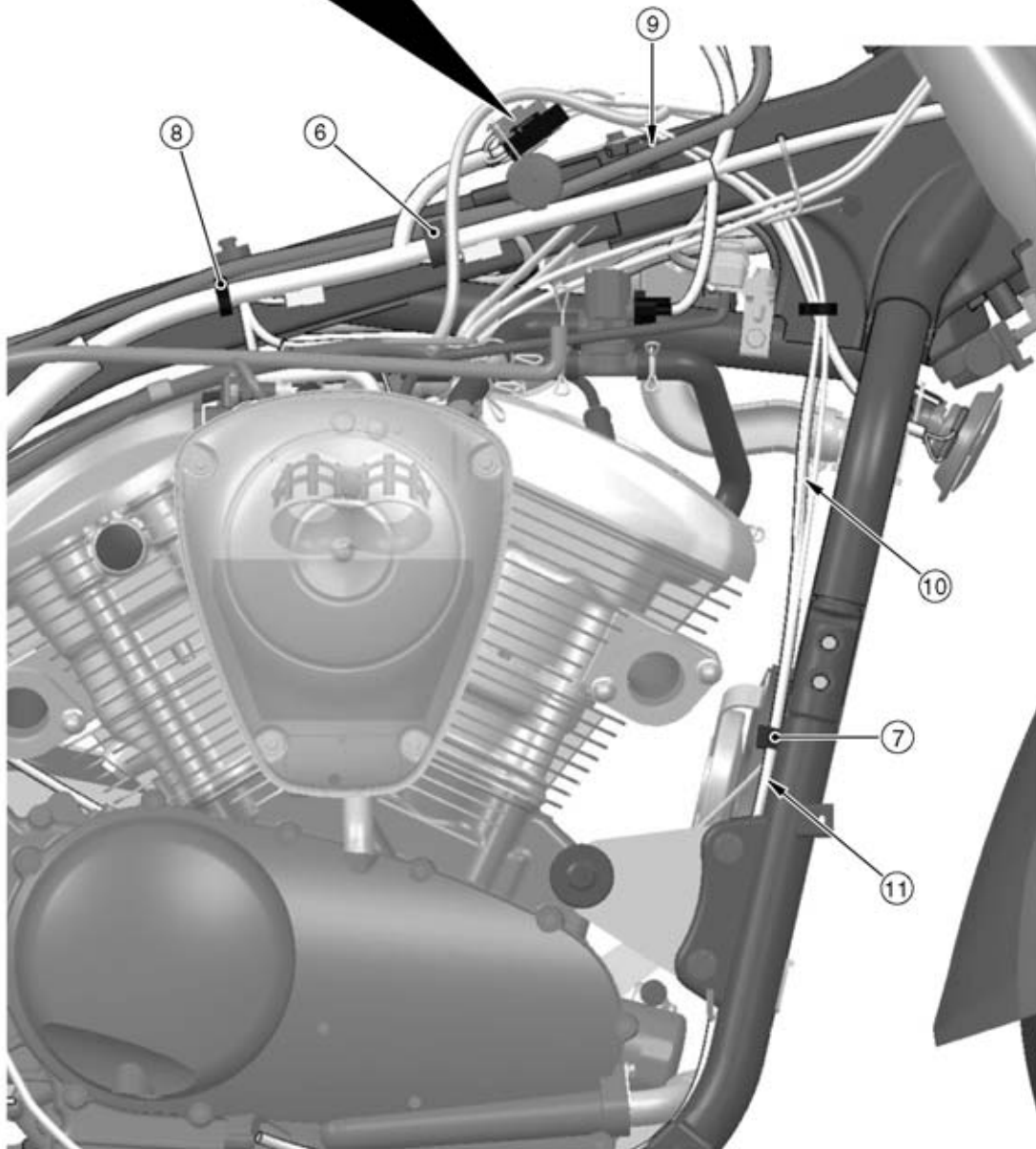
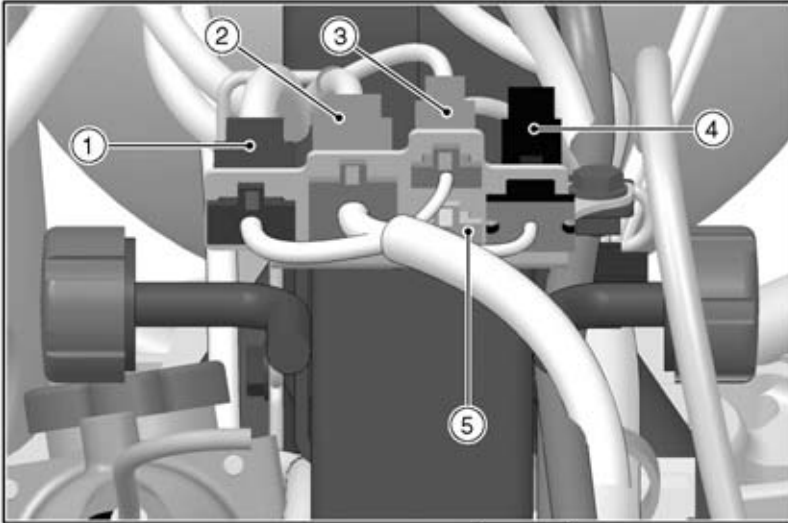

GB09166C G

Cable, Wire, and Hose Routing

1. Right Switch Housing Lead Connector
2. Left Switch Housing Lead Connector
3. Left Switch Housing Lead Connector
4. Radiator Fan Lead Connector
5. Rear Brake Light Switch Lead Connector
6. Clamp the main harness.
7. Clamp the clutch cable, rear brake light switch lead and radiator fan lead.
8. Insert the harness attached clamp to the frame pipe.
9. Insert the harness attached clamp to the frame welding clamp.
10. Run the clutch cable between the frame and radiator hose.
11. Run the clutch cable and rear brake light switch lead inside the engine bracket.

17-8 APPENDIX

Cable, Wire, and Hose Routing

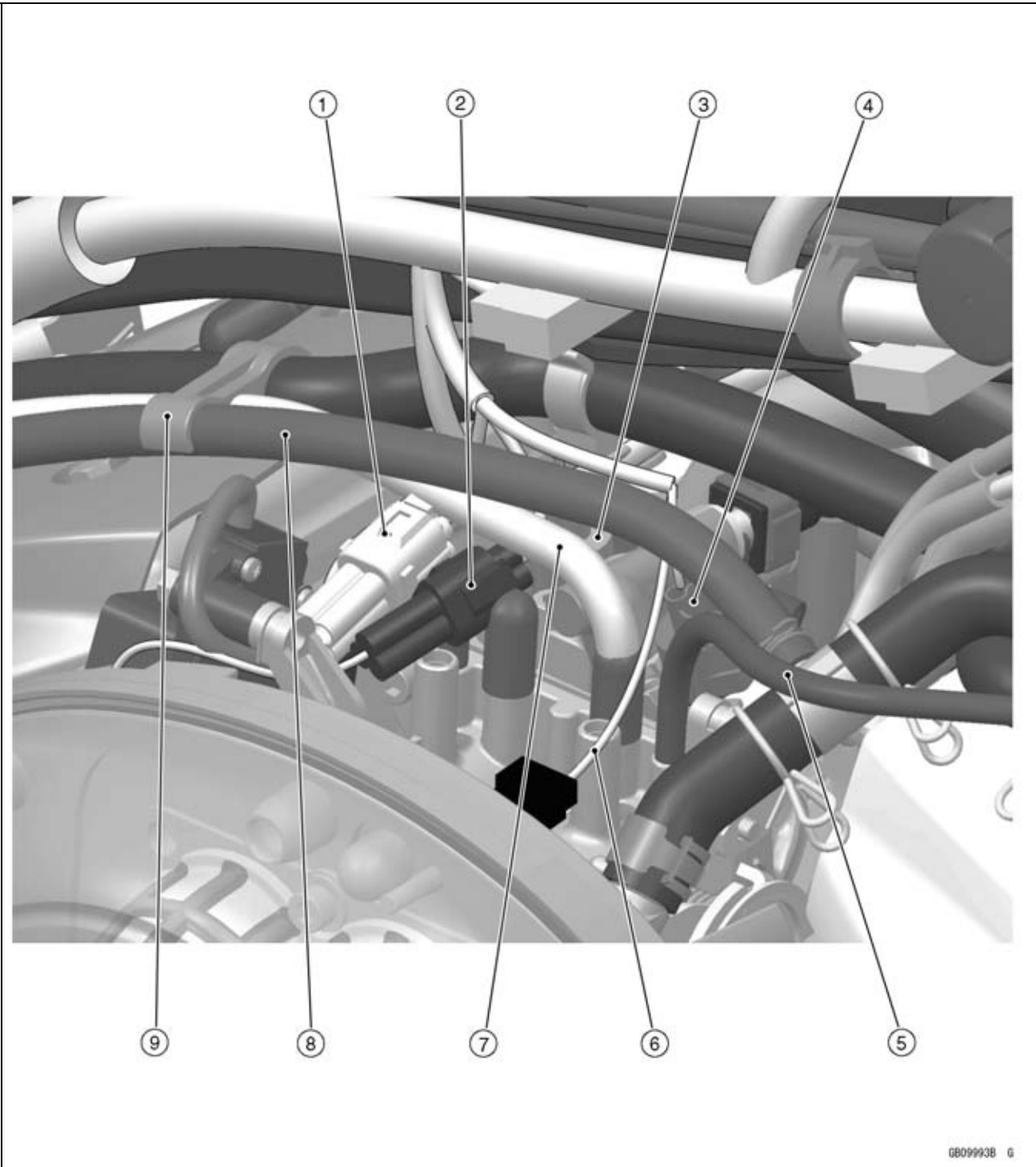

Cable, Wire, and Hose Routing

1. Subthrottle Valve Actuator Lead Connector
2. Subthrottle Sensor Lead Connector
3. Injector #2 Lead Connector
4. Injector #1 Lead Connector
5. Inlet Air Pressure Sensor Vacuum Hose
6. Inlet Air Temperature Sensor Lead (CAL, TH and SEA-B1 Models: Run the inlet air temperature sensor lead between the vacuum hose and purge hose.)
7. Vacuum Hose (CAL, TH and SEA-B1 Models)
8. Purge Hose (CAL, TH and SEA-B1 Models)
9. Clamp the air switching valve hose, vacuum hose and purge hose.

17-10 APPENDIX

Cable, Wire, and Hose Routing

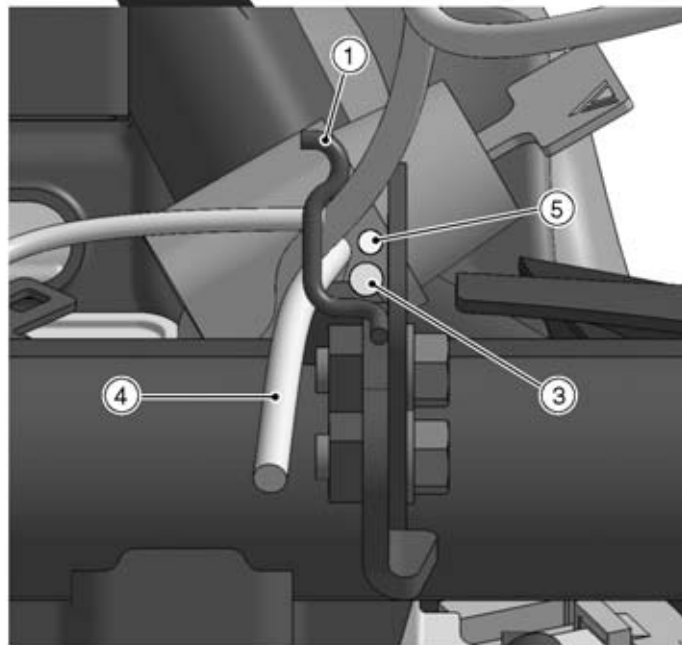
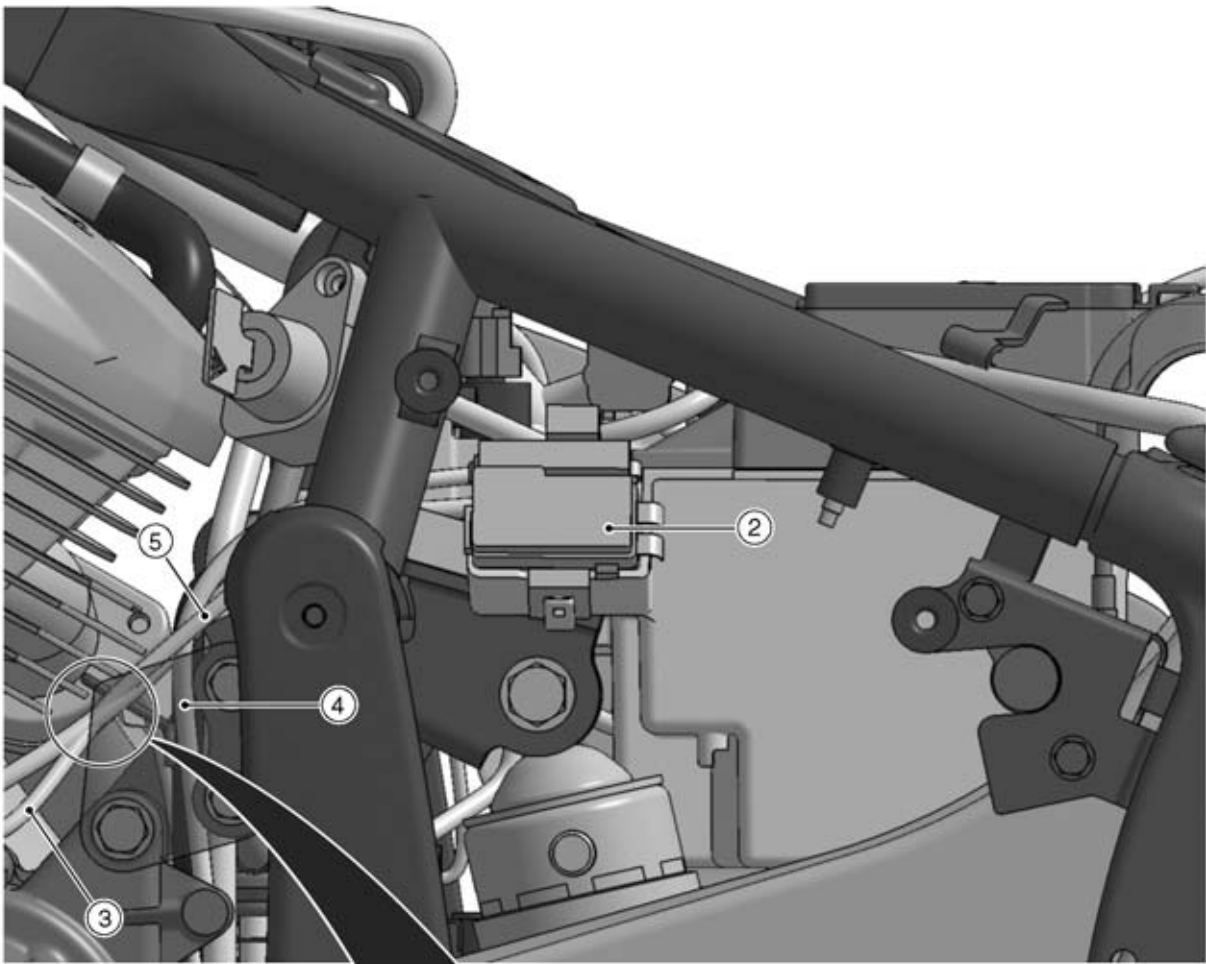

6

GB09167C G

Cable, Wire, and Hose Routing

1. Run the alternator lead and sidestand switch lead through the clamp of the engine bracket.
2. Fuse Box
3. Alternator Lead
4. Battery Negative (-) Cable
5. Sidestand Switch Lead
6. View from the front

17-12 APPENDIX

Cable, Wire, and Hose Routing

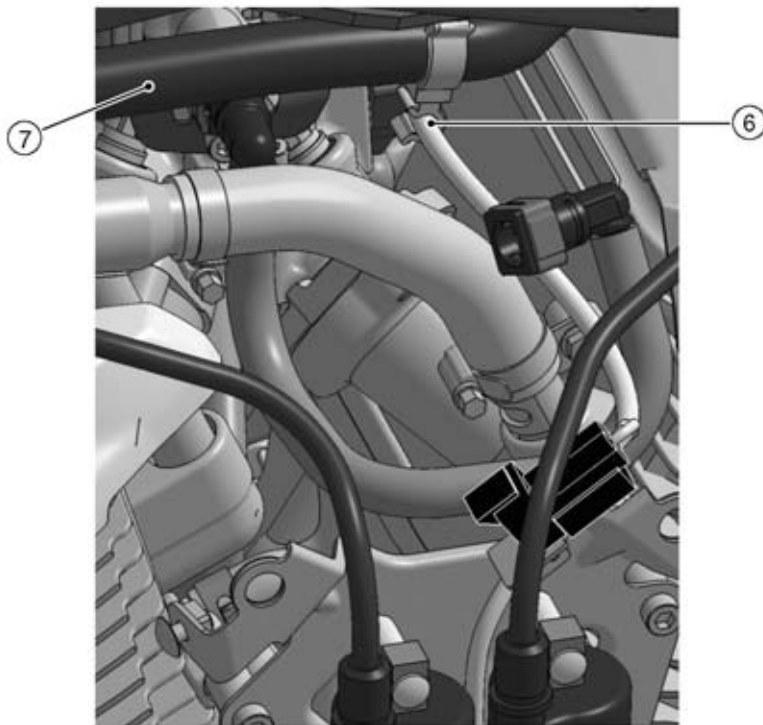
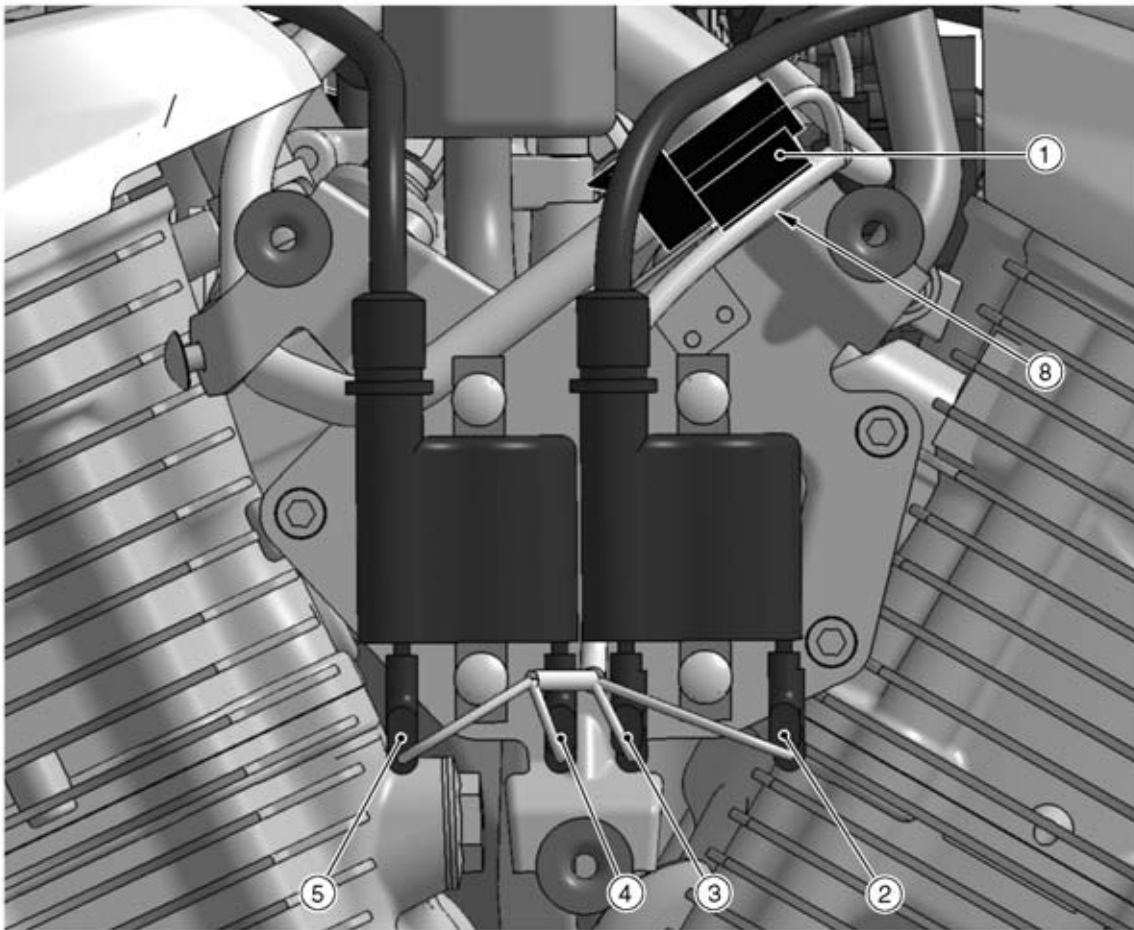

GB09168C G

Cable, Wire, and Hose Routing

1. Fuel Pump Lead Connector
2. Black/Green Lead
3. Red Lead
4. Black Lead
5. Red Lead
6. Clamp the ignition coil lead with the air switching valve hose clamp.
7. Air Switching Valve Hose
8. Run the ignition coil lead under the fuel pump lead connector, and run the ignition coil lead between the ignition coil #1 and ignition coil #2.

17-14 APPENDIX

Cable, Wire, and Hose Routing

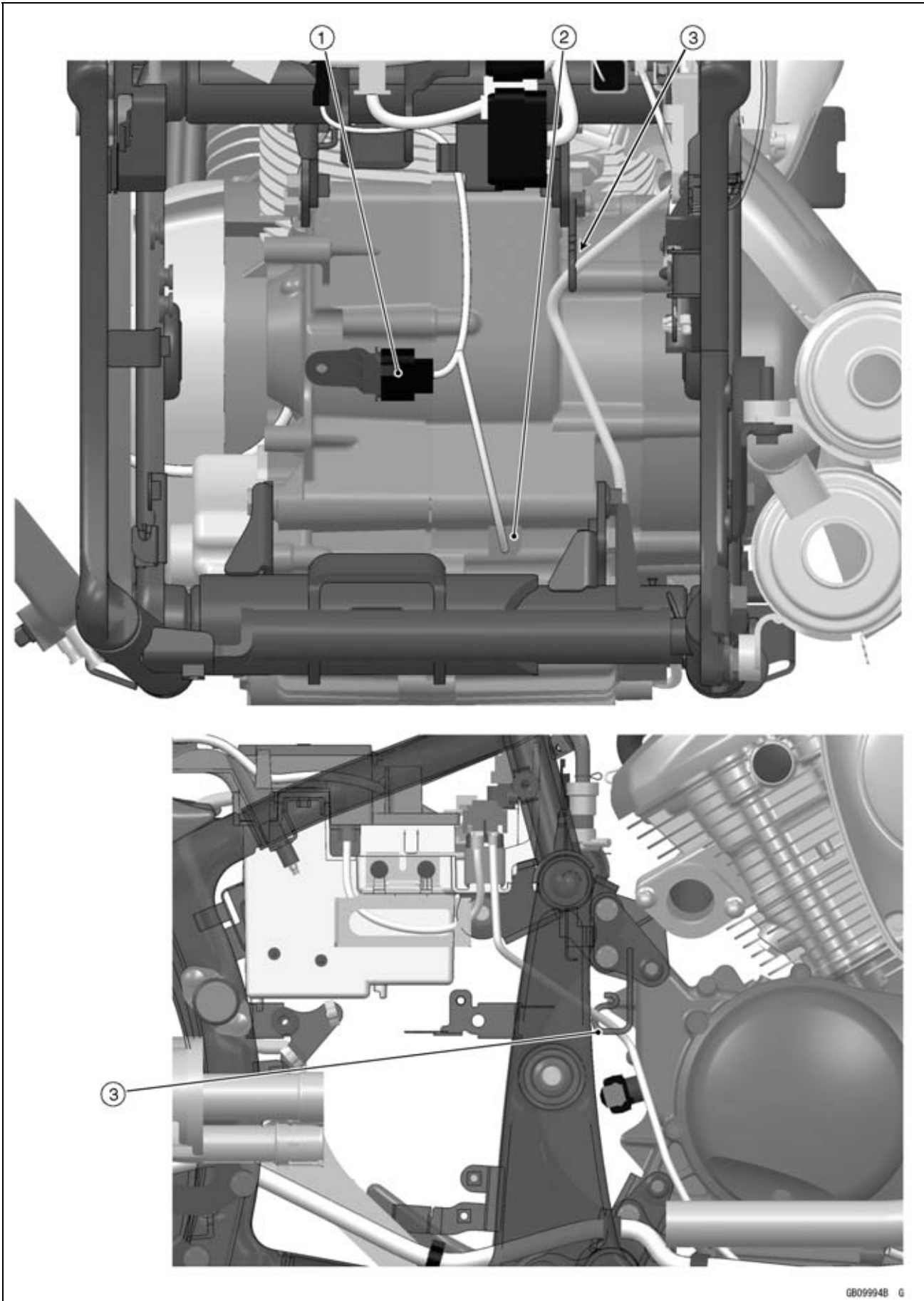

GB09994B G

Cable, Wire, and Hose Routing

1. Speed Sensor Lead Connector
2. Neutral Switch Lead Terminal
3. Run the starter motor lead through the engine bracket clamp.

17-16 APPENDIX

Cable, Wire, and Hose Routing

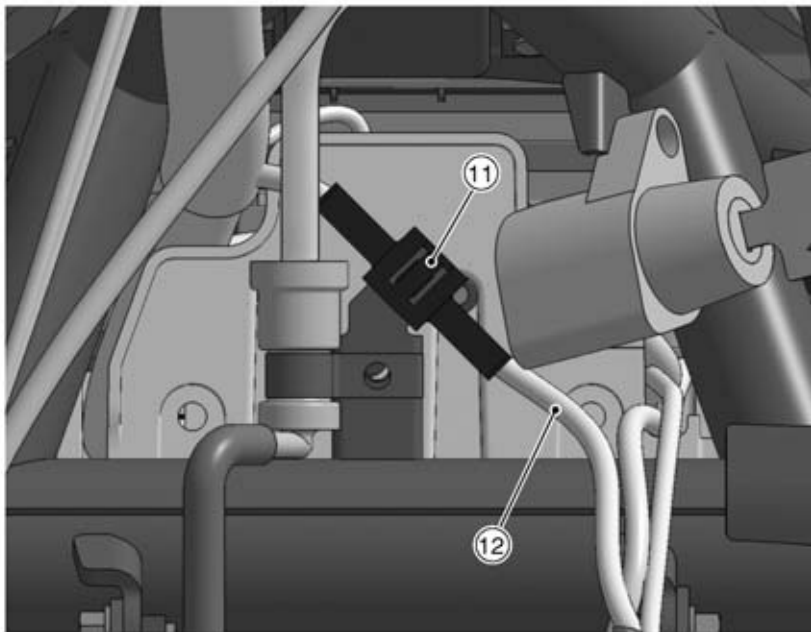
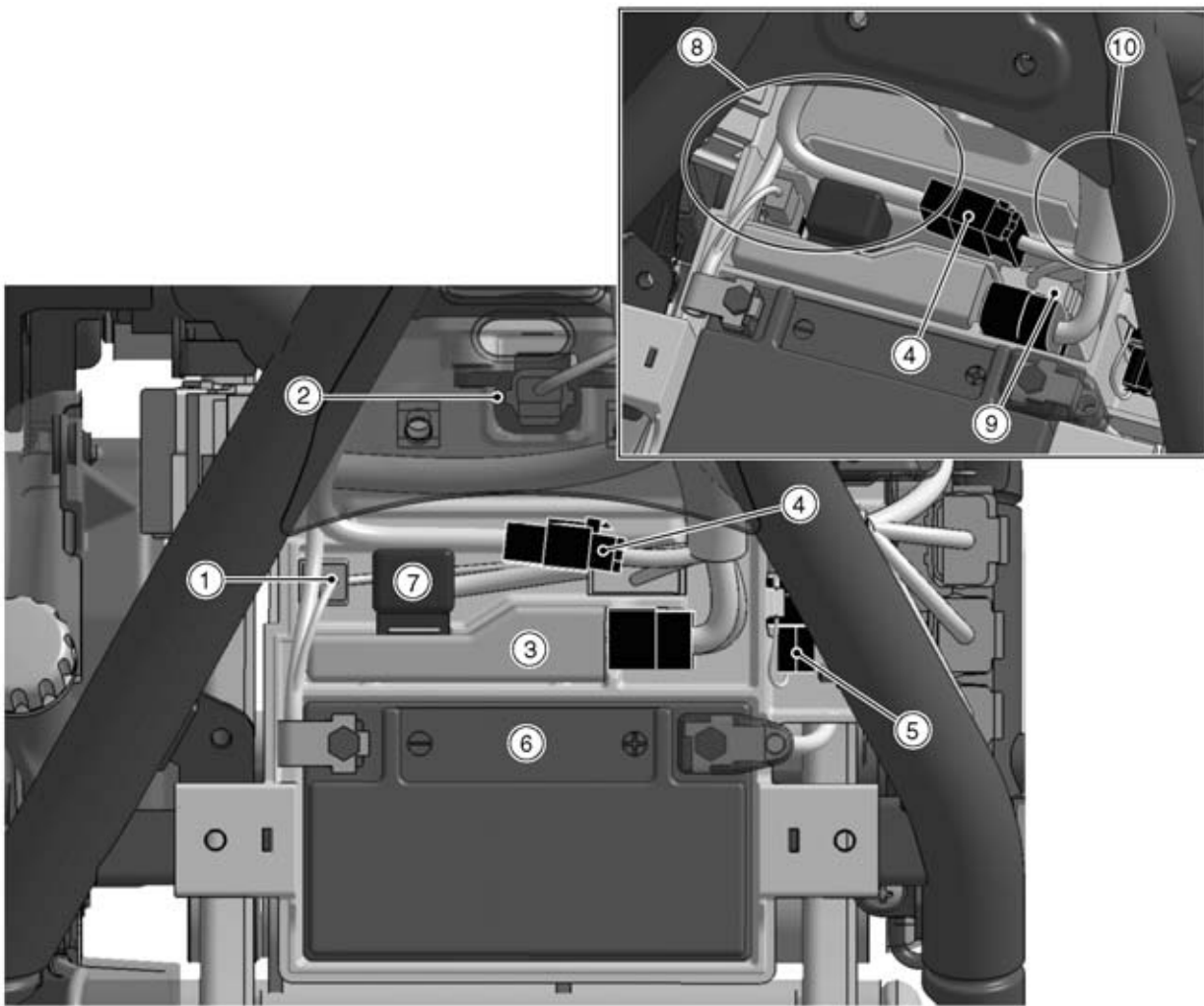

13

Cable, Wire, and Hose Routing

1. Connect the battery negative (-) lead connector to the main harness.
2. Vehicle-down Sensor
3. ECU
4. Ignition Switch Lead Connector
5. Kawasaki Diagnostic System Connector
6. Battery
7. Turn Signal Relay
8. Run the ignition switch lead in the front of the turn signal relay, and run the ignition switch lead and engine ground lead through the notch of the battery case.
9. Joint Connector (Put the joint connector under the ignition switch lead connector.)
10. Run the main harness through the notch of the battery case.
11. Insert the harness attached clamp to the frame bracket.
12. Sidestand Switch Lead
13. View from the front

17-18 APPENDIX

Cable, Wire, and Hose Routing

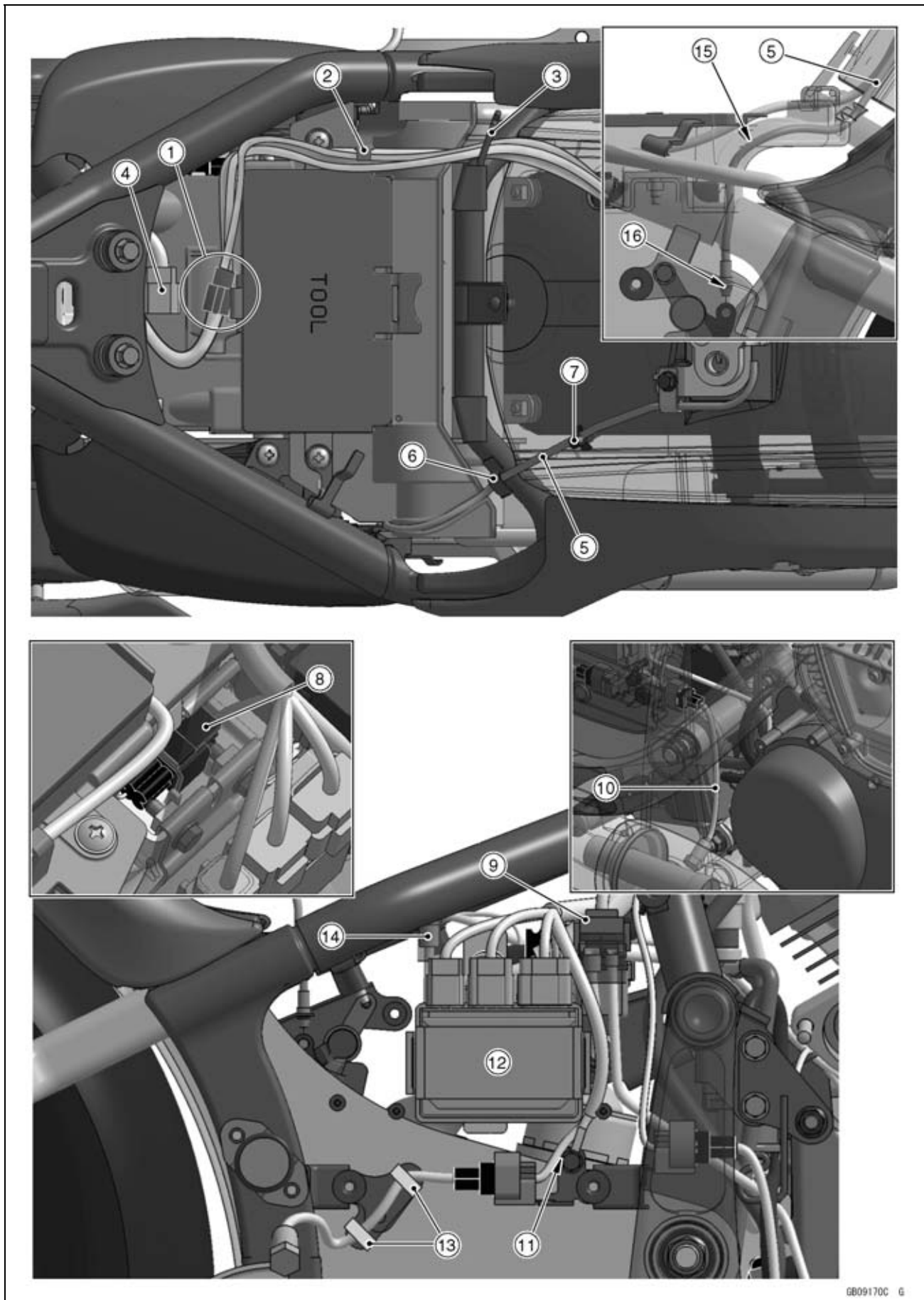

GB09170C G

Cable, Wire, and Hose Routing

1. Rear Left and Right Turn Signal Light, Tail/Brake Light and License Plate Light Lead Connector
2. Run the rear left and right turn signal light, tail/brake light and license plate light lead through the guide of the tool box.
3. Run the rear left and right turn signal light, tail/brake light and license plate light lead through the guide of the frame.
4. Alternator Lead Connector
5. Seat Lock Cable
6. Run the seat lock cable through the guide of the frame.
7. Run the seat lock cable through the clamp, and insert the clamp in the rear fender.
8. Kawasaki Diagnostic System Lead Connector
9. Starter Relay
10. Run the oxygen sensor #1 lead inside the rear exhaust pipe (Oxygen Sensor Equipped models).
11. Run the oxygen sensor #2 lead sideward the frame ground bolt (Oxygen Sensor Equipped models).
12. Relay Box
13. Clamp the oxygen sensor #2 lead, and fix the clamp to the frame bracket (Oxygen Sensor Equipped models).
14. Run the battery positive (+) cable inside the relay box bracket.
15. Run the seat lock cable through the guide of the battery cover.
16. Fix the seat lock cable to the notch of the frame bracket.

17-20 APPENDIX

Cable, Wire, and Hose Routing

VN900C7 ~ CB

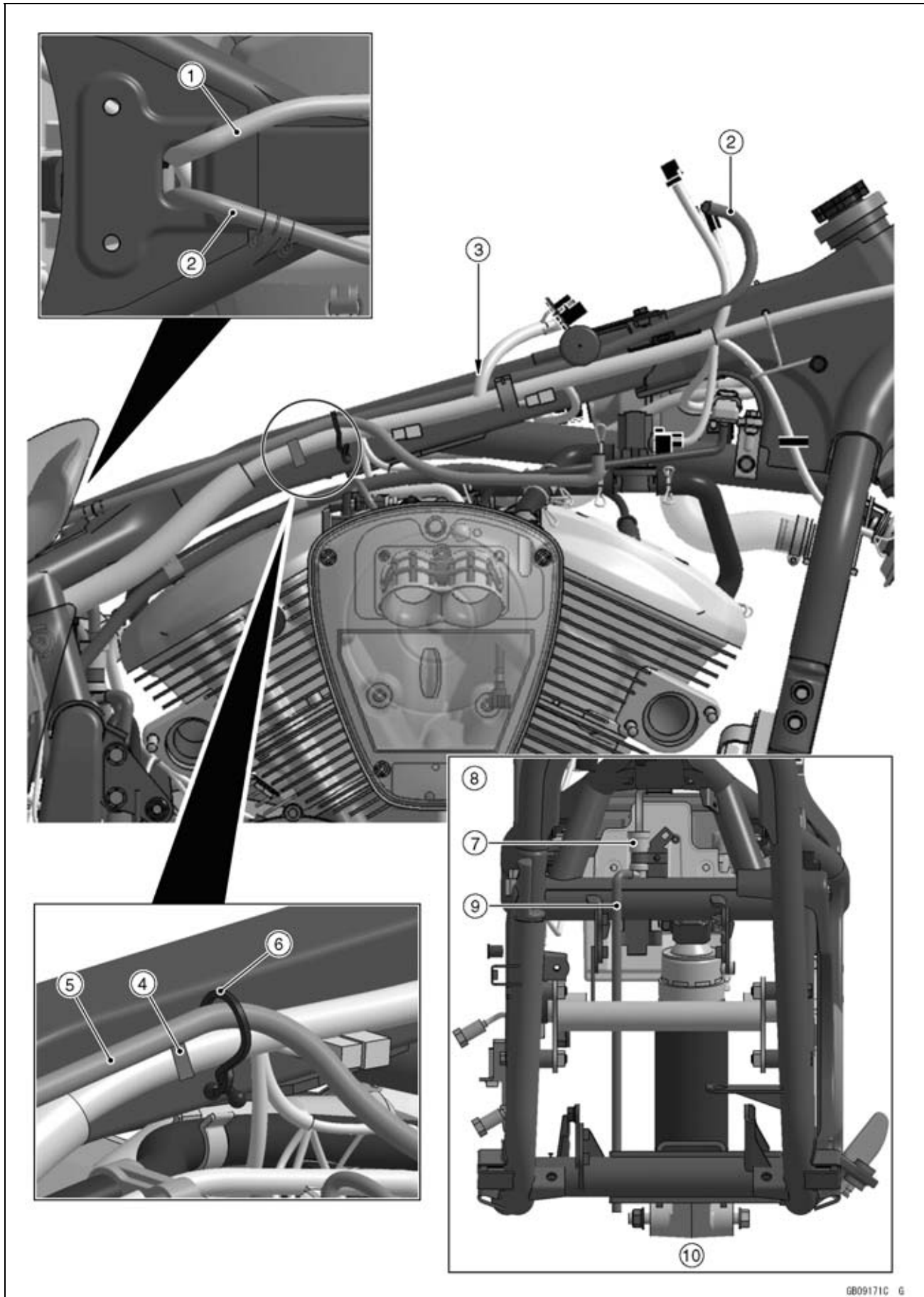

GB09171C 6

Cable, Wire, and Hose Routing

1. Reserve Tank Hose
2. Breather Hose
3. Run the breather hose inside the main harness.
4. Harness Attached Clamp (Insert the harness attached clamp to the frame pipe.)
5. Fuel Return Hose (CAL, TH and SEA-B1 Models)
6. Clamp the main harness, breather hose and fuel return hose.
7. Breather Check Valve
8. Other than CAL, TH and SEA-B1 Models
9. Run the breather hose inside the engine bracket and frame cross pipe front.
10. Viewed from the front

17-22 APPENDIX

Cable, Wire, and Hose Routing

VN900C7 ~

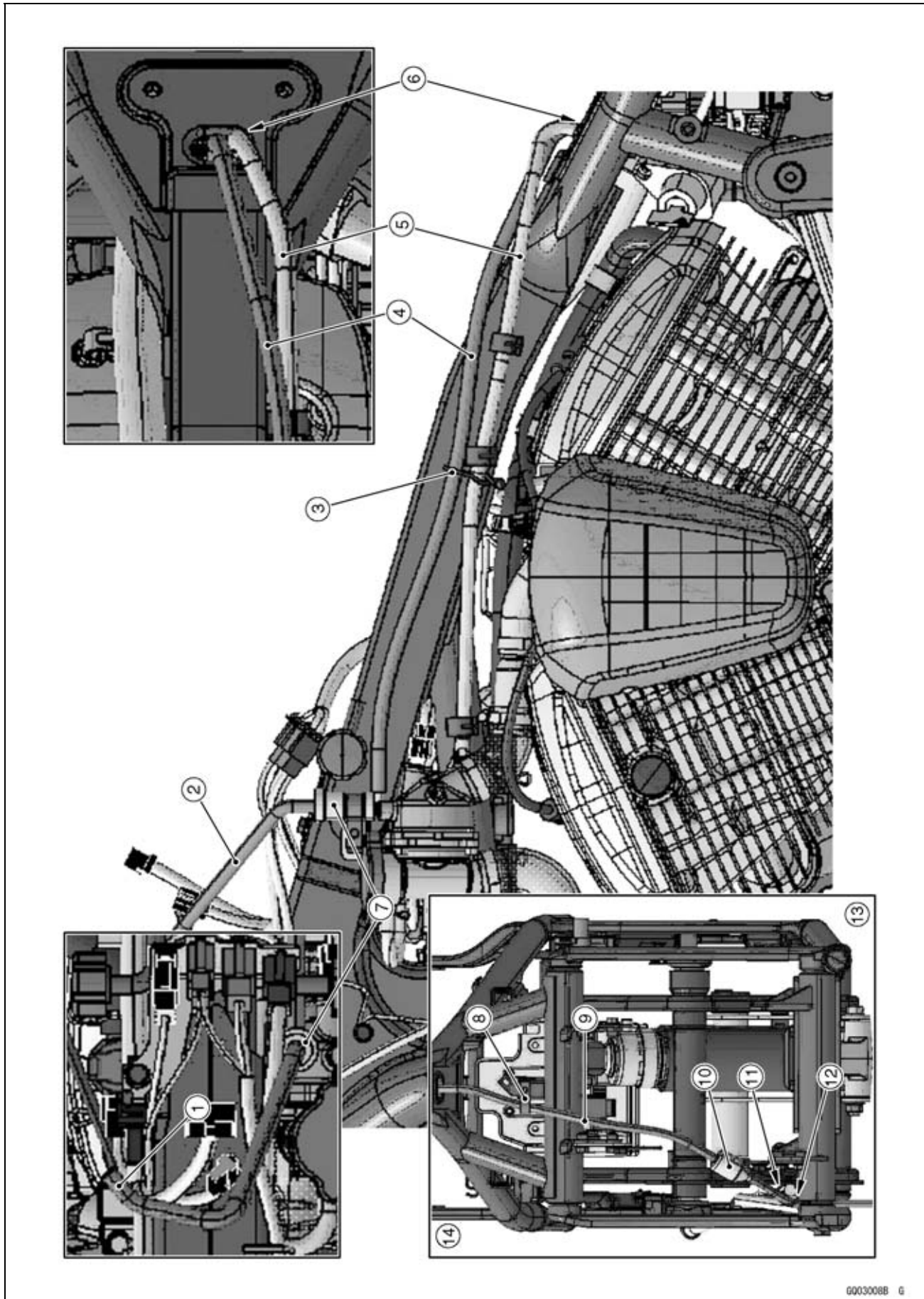

Cable, Wire, and Hose Routing

1. Connect the breather hose to fuel tank breather pipe at front of the fuel tank.
2. Breather Hose
3. Clamp the breather hose and reserve tank hose. Do not pinch the hoses. Position the clamp as shown in the figure.
4. Breather Hose
5. Reserve Tank Hose
6. Run the breather hose and reserve hose into the hole in the frame.
7. Breather Check Valve
8. Clamp
9. Run the breather hose inside the engine bracket and front side of the frame cross pipe.
10. Breather
11. Clamp the breather hose and rear brake hose.
12. Run the breather hose outside rear brake hose and rear side of the frame cross pipe.
13. Other than CAL, TH and SEA-B1 Models
14. Viewed from the front

17-24 APPENDIX

Cable, Wire, and Hose Routing

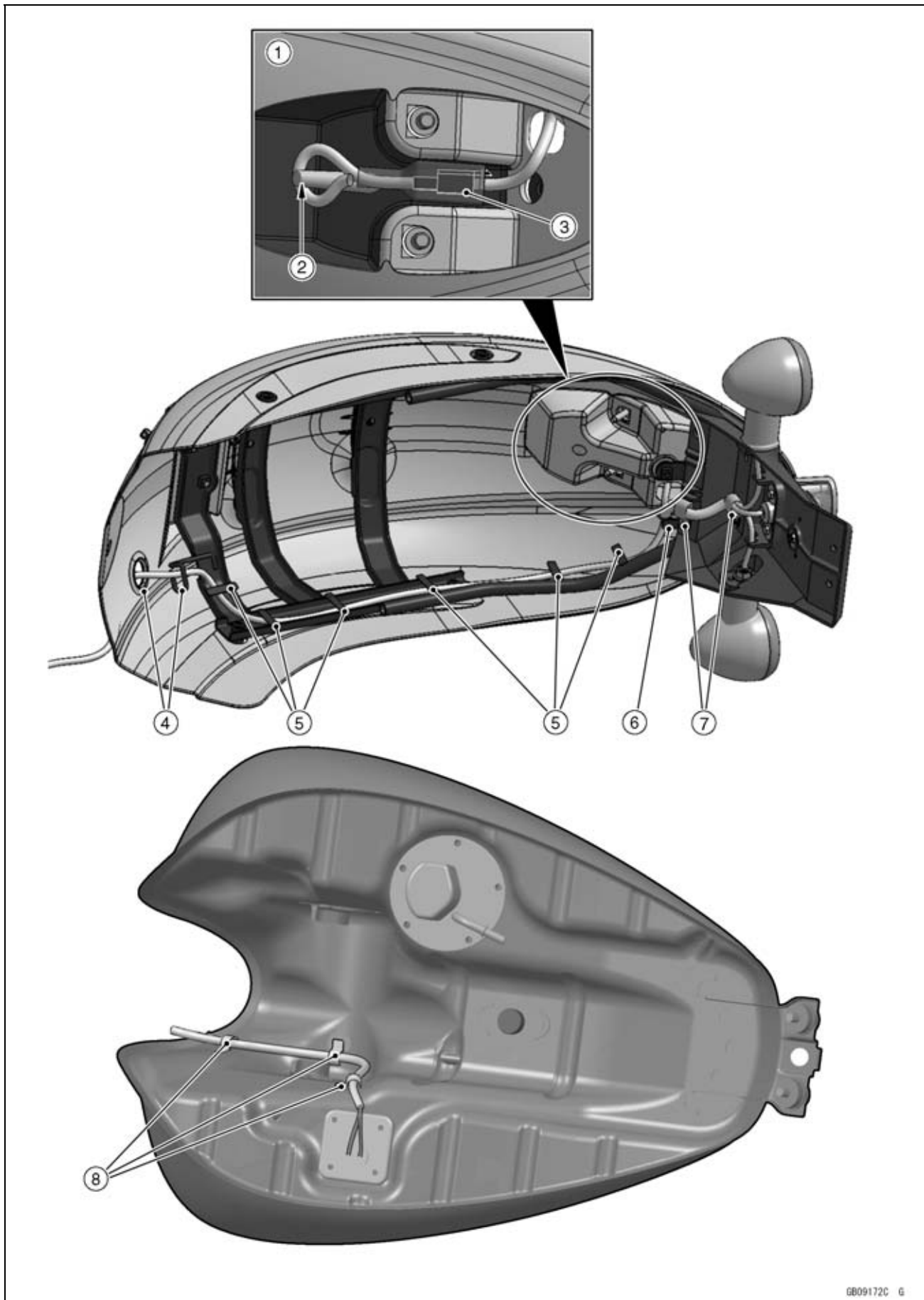

GB09172C G

Cable, Wire, and Hose Routing

1. View from the outside
2. Roll the tail/brake light lead to the pin.
3. Cover the tail/brake light lead connector by cover of the harness attached, and put the tail/brake light lead connector to the guide of the rear fender.
4. Run the rear left and right turn signal light, tail/brake light and license plate light lead through the fender hole and guide.
5. Clamp the rear left and right turn signal light, tail/brake light and license plate light lead with the reinforce attached clamps.
6. Run the rear left and right turn signal light, tail/brake light and license plate light lead through the reinforce attached clamp.
7. Clamp the rear left and right turn signal light and license plate light lead.
8. Clamp the fuel level sensor lead with the fuel tank attached clamps.

17-26 APPENDIX

Cable, Wire, and Hose Routing

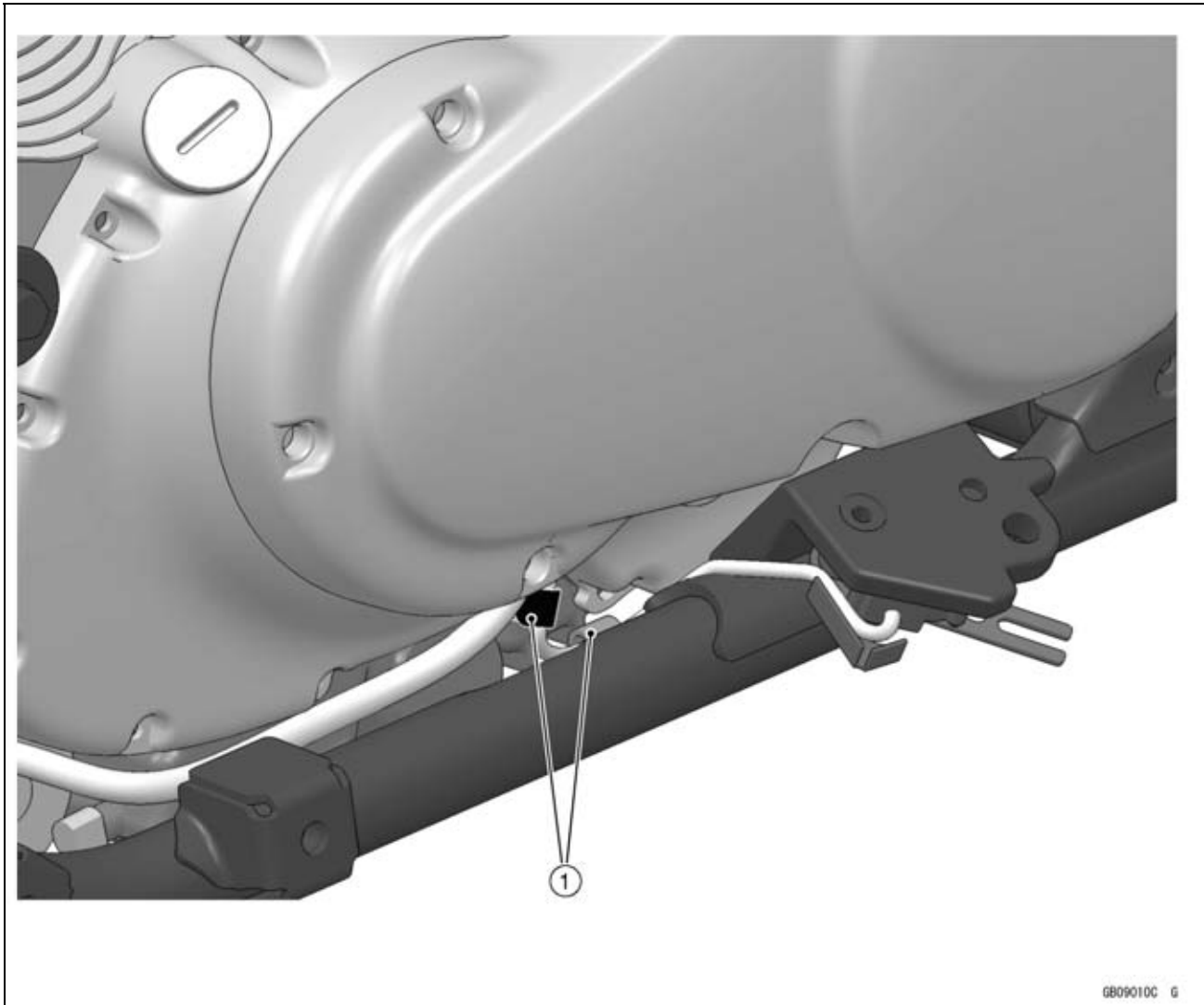

1. Clamps (Clamp the sidestand switch lead.)

Cable, Wire, and Hose Routing

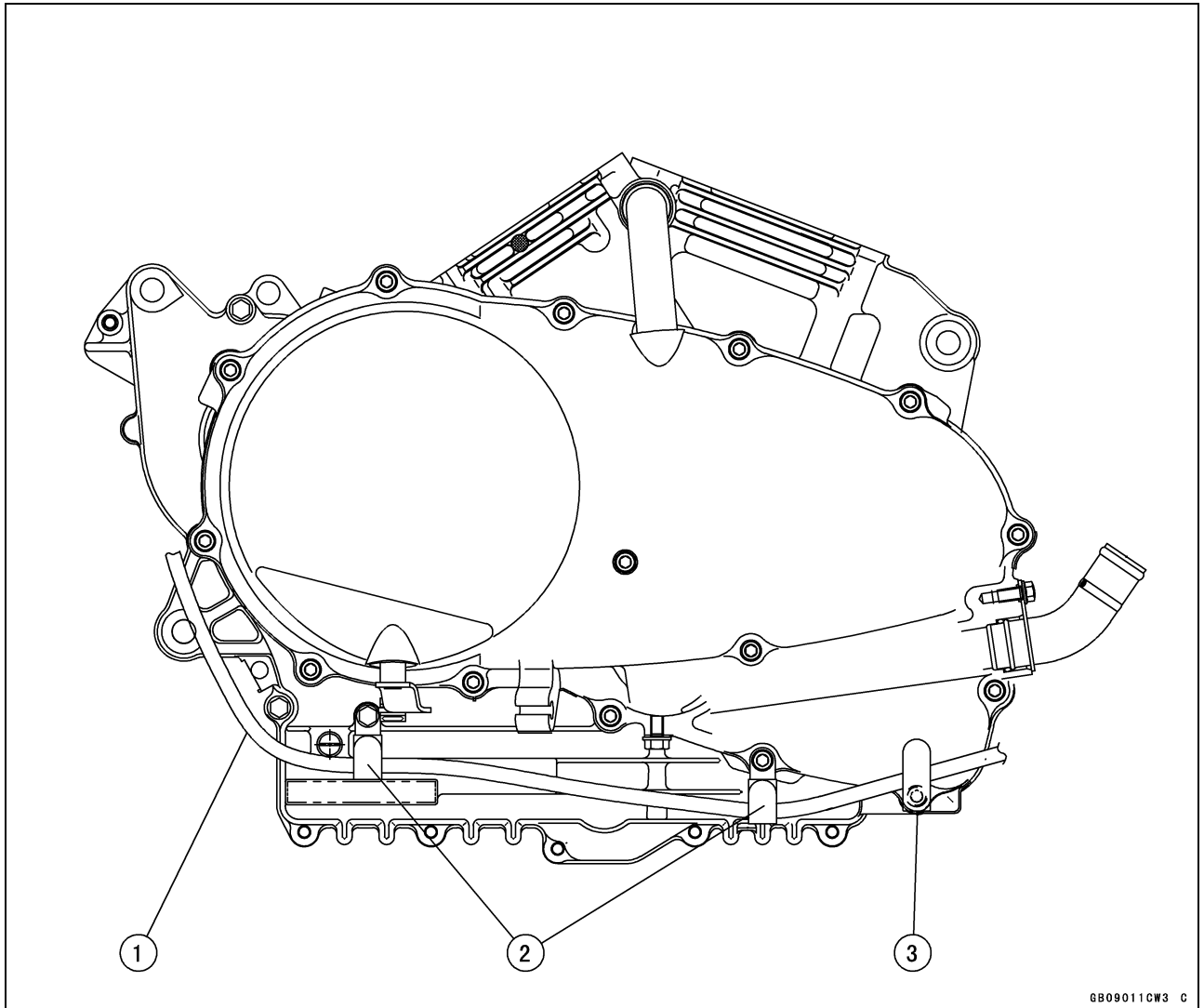

GB090110W3 C

1. Starter Motor Cable
2. Clamps
3. Clamp (Bend the clamp as shown in the figure.)

17-28 APPENDIX

Cable, Wire, and Hose Routing

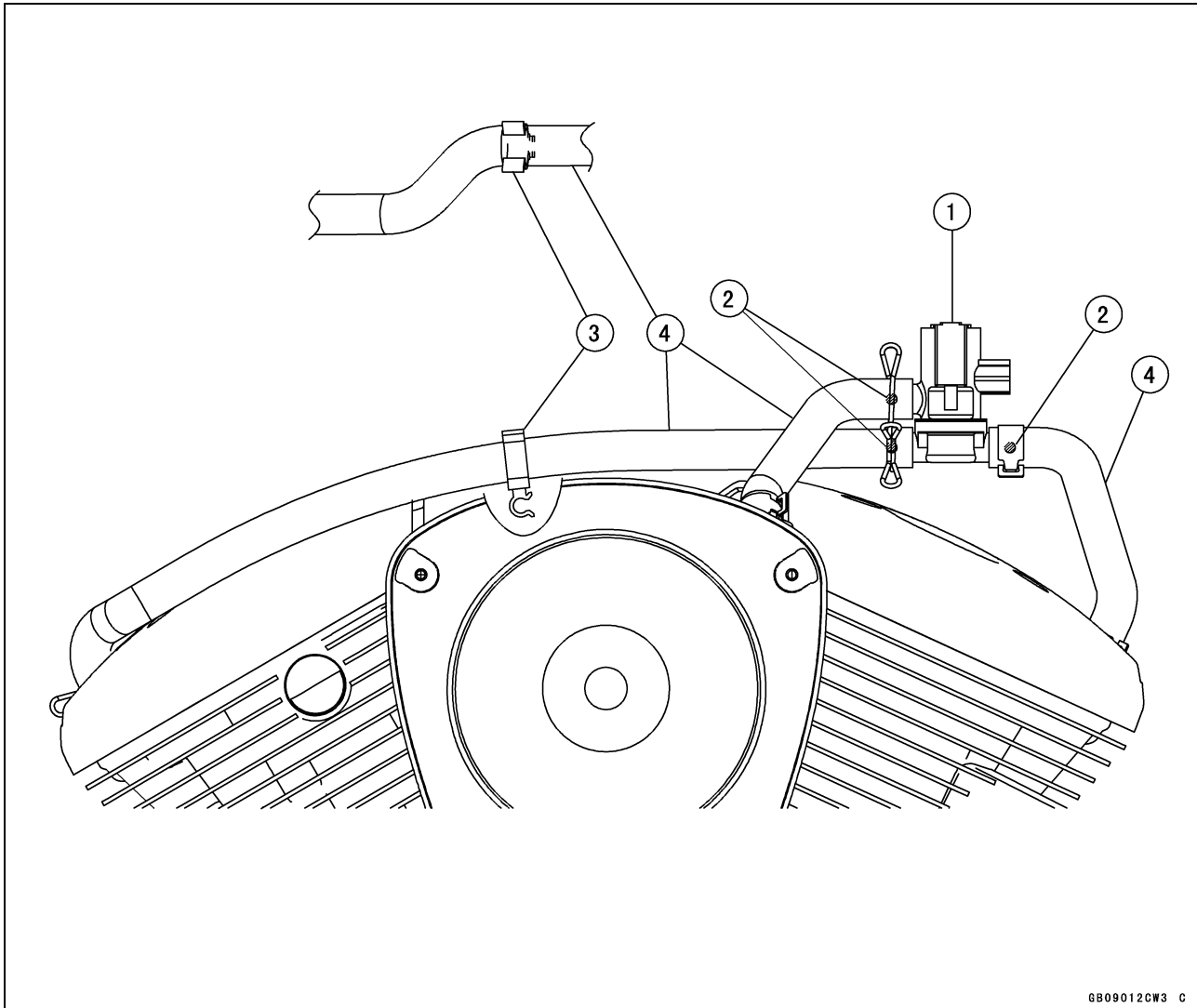

1. Air Switching Valve
2. Face the white mark right side.
3. Clamp (for Ignition Coil Lead)
4. Air Switching Valve Hose

Cable, Wire, and Hose Routing

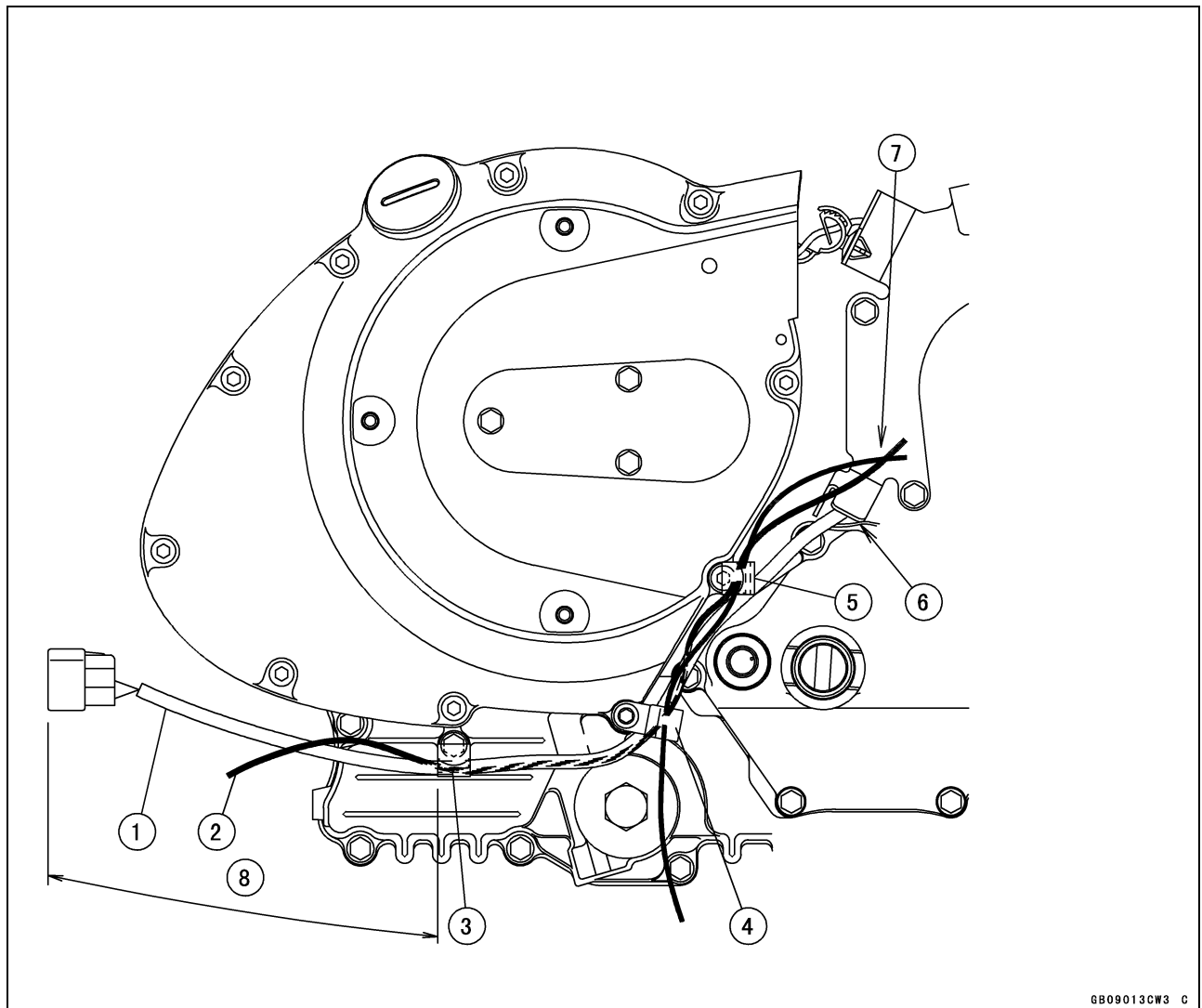

GB090130W3 C

1. Alternator Coil Lead
2. Oil Pressure Switch Lead
3. Clamp the alternator lead and oil pressure switch lead. After installed, bend the clamp to the alternator cover.
4. Clamp the sidestand switch lead only.
5. Clamp the oil pressure switch lead and sidestand switch lead. After installed, bend the clamp to the alternator cover.
6. Run the alternator lead through the inside of the engine pulley plate.
7. Run the oil pressure switch lead and sidestand switch lead through the outside of the engine pulley cover.
8. About 250 ±10 mm (9.84 ±0.39 in.)

17-30 APPENDIX

Cable, Wire, and Hose Routing

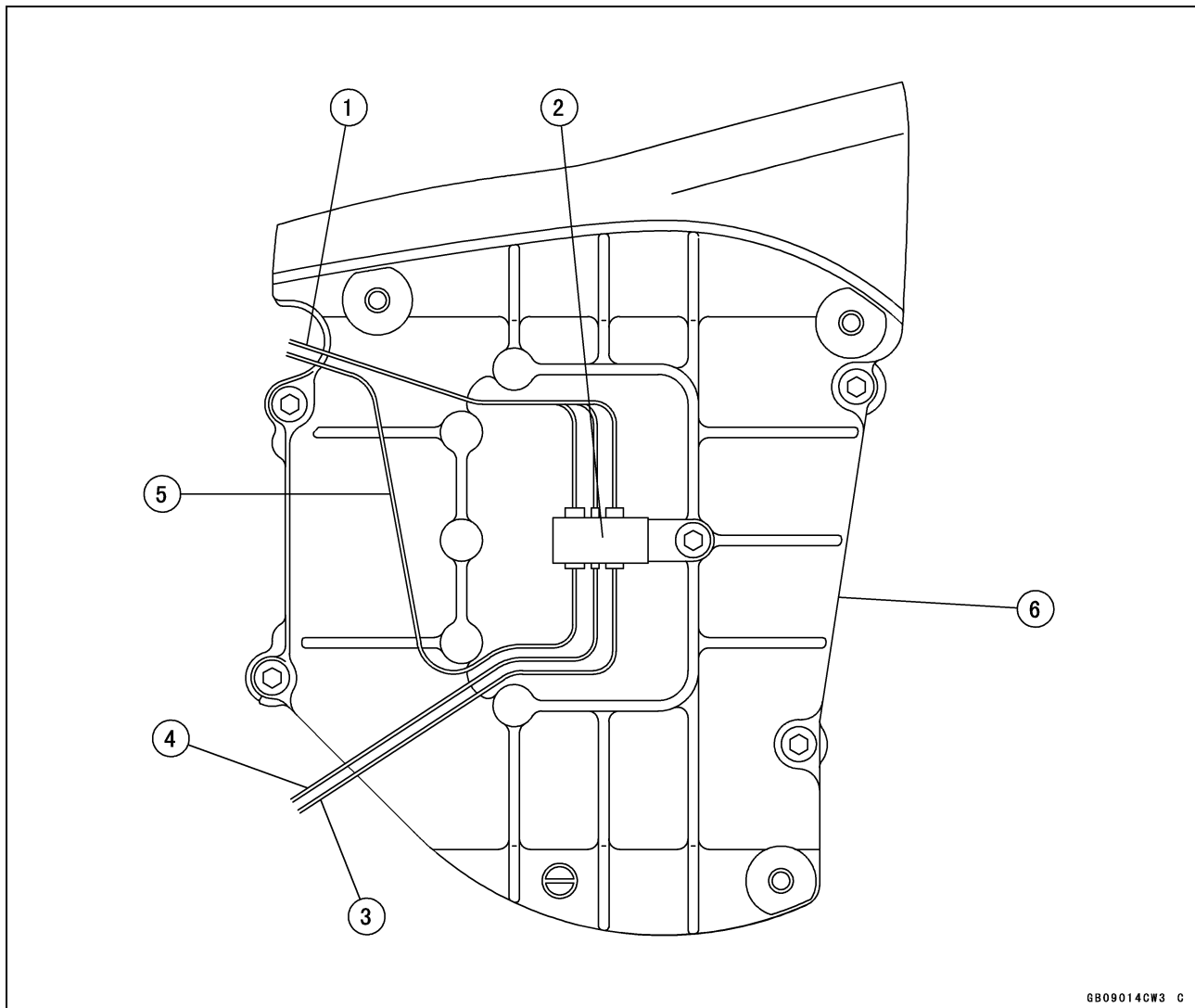

1. Main Harness
2. Clamp (Wrap the connectors.)
3. Sidestand Switch Lead
4. Oil Pressure Switch Lead
5. Crankshaft Sensor Lead
6. Engine Pulley Cover

Cable, Wire, and Hose Routing

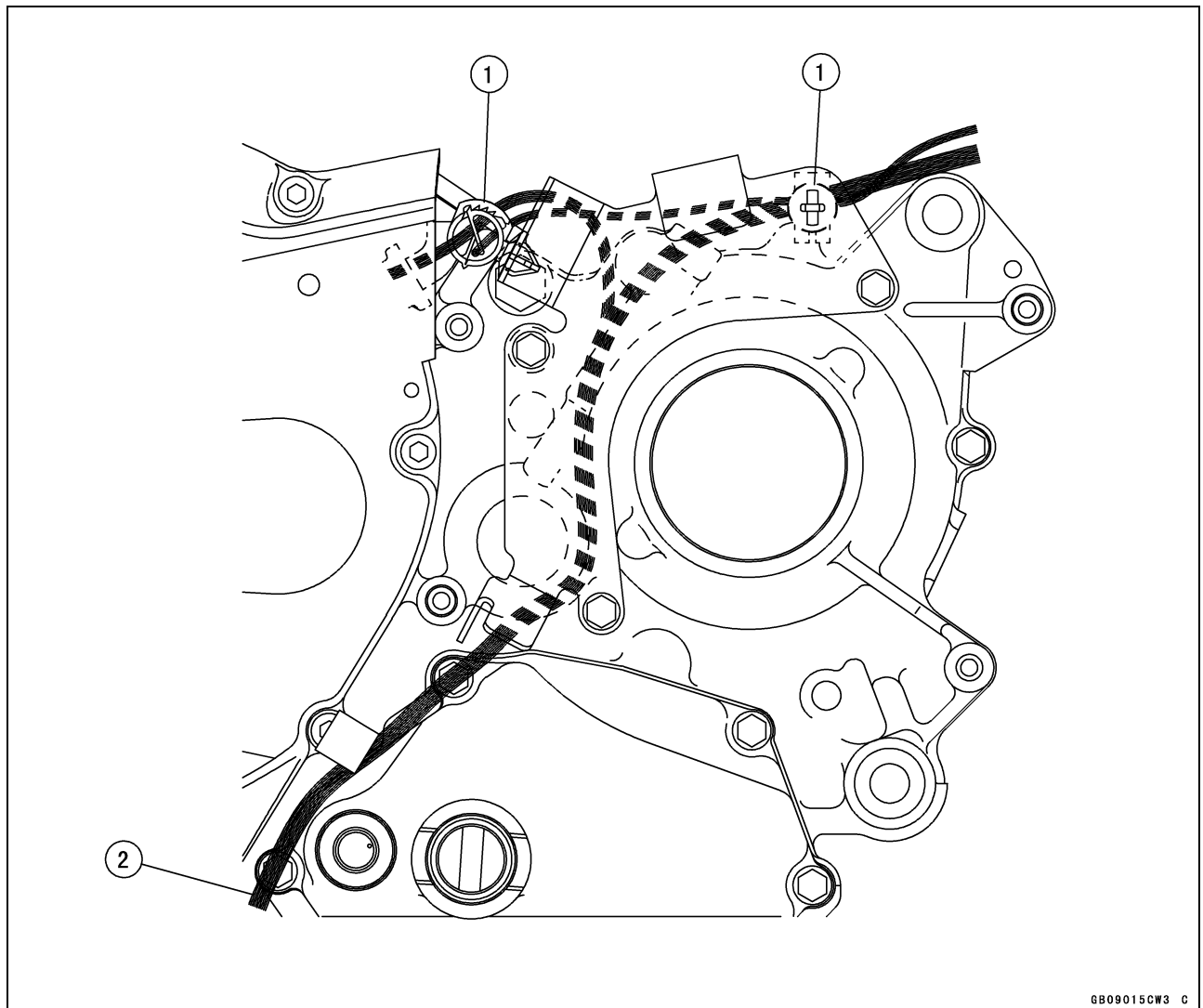

1. Clamp the alternator lead and main harness.
2. Alternator Lead

17-32 APPENDIX

Cable, Wire, and Hose Routing

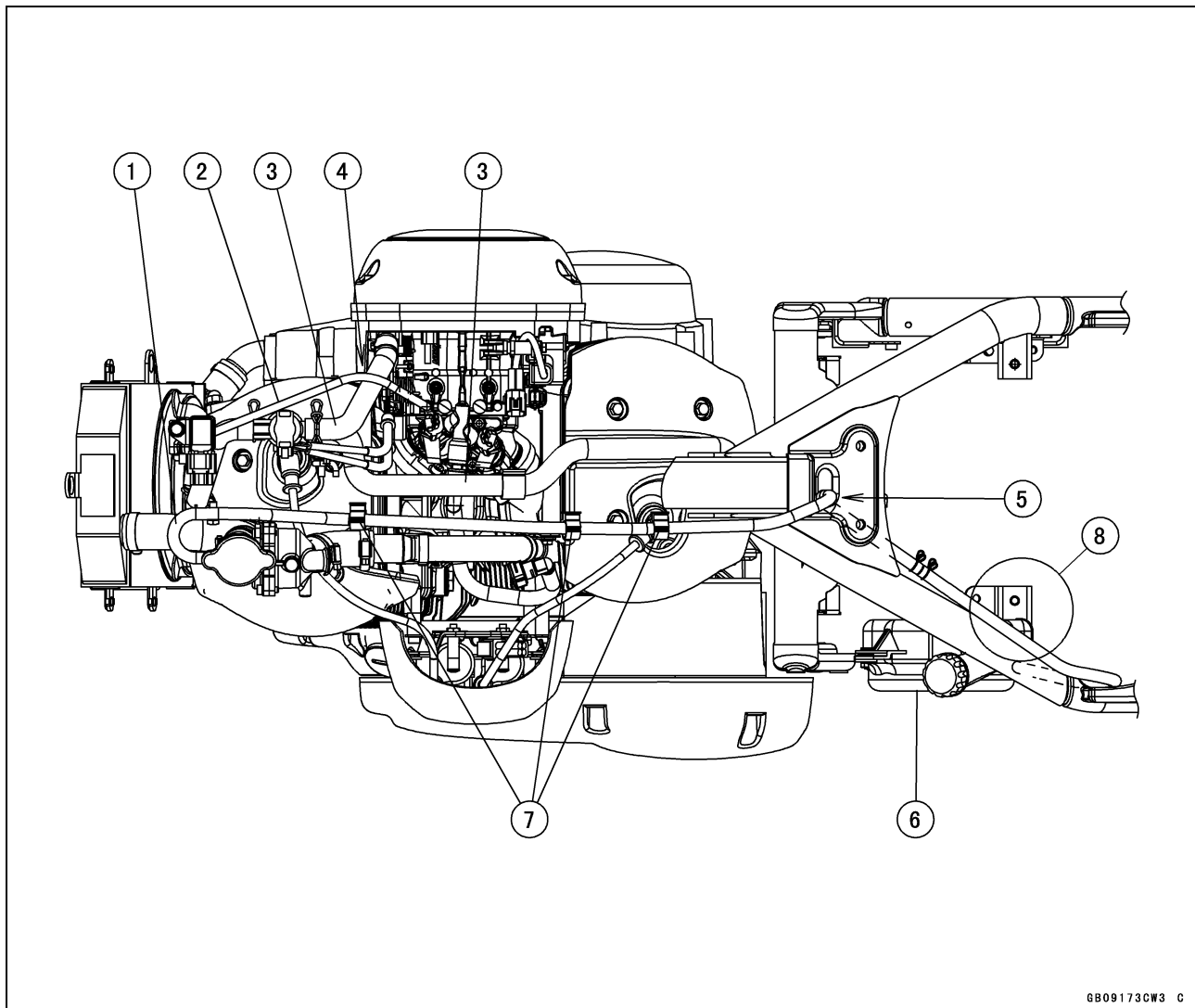

GB09173CW3 C

1. Reserve Tank Hose
2. Inlet Air Pressure Sensor Vacuum Hose
3. Air Switching Valve Hoses
4. Run the inlet air pressure sensor vacuum hose over the air switching valve hose.
5. Run the reserve tank hose into the frame hole.
6. Reserve Tank
7. Clamps
8. Run the reserve tank hose on the battery case bracket.

Cable, Wire, and Hose Routing

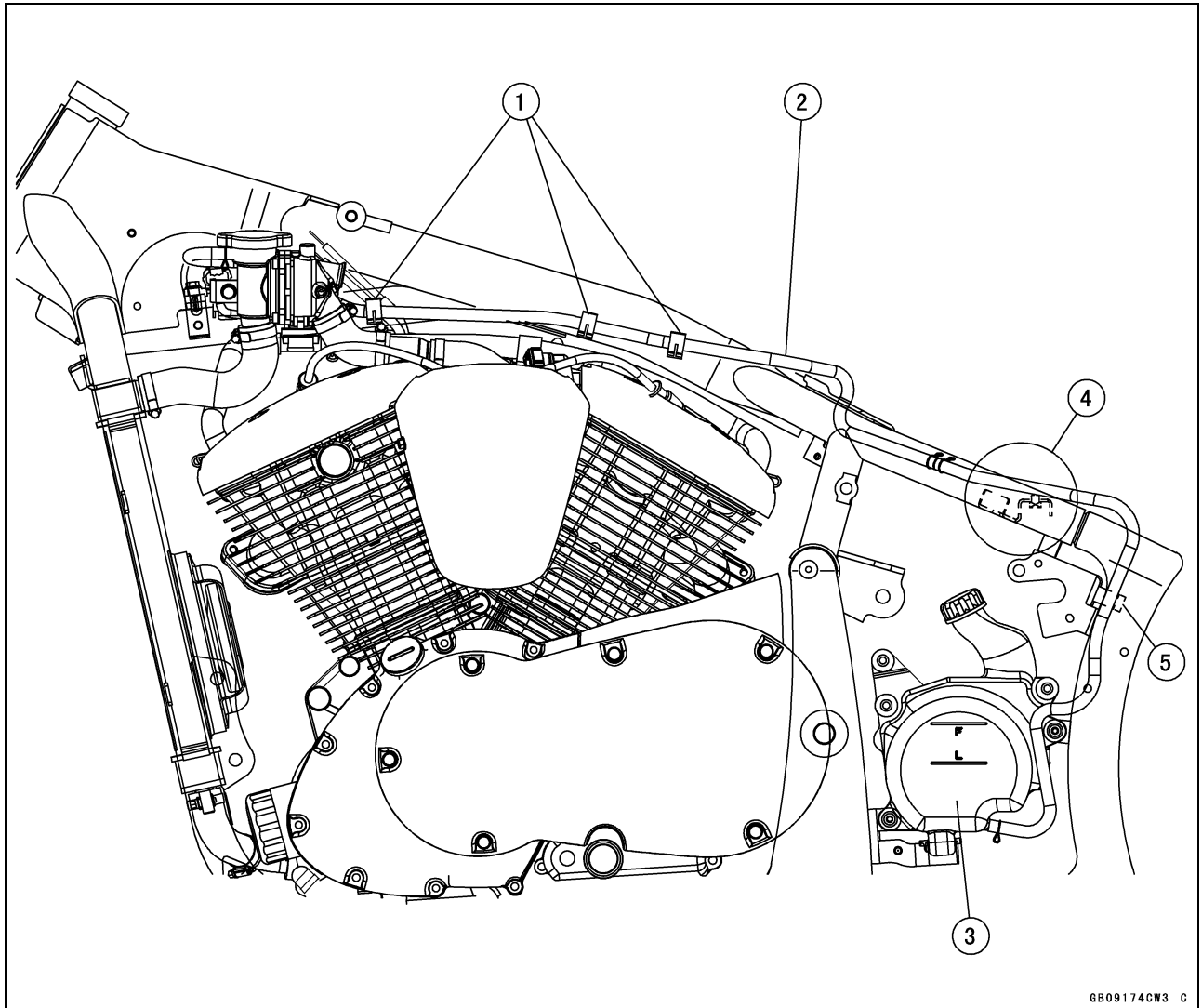

1. Clamps
2. Reserve Tank Hose
3. Reserve Tank
4. Run the reserve tank hose on the battery case bracket.
5. Clamp (Clamp the reserve tank hose.)

17-34 APPENDIX

Cable, Wire, and Hose Routing

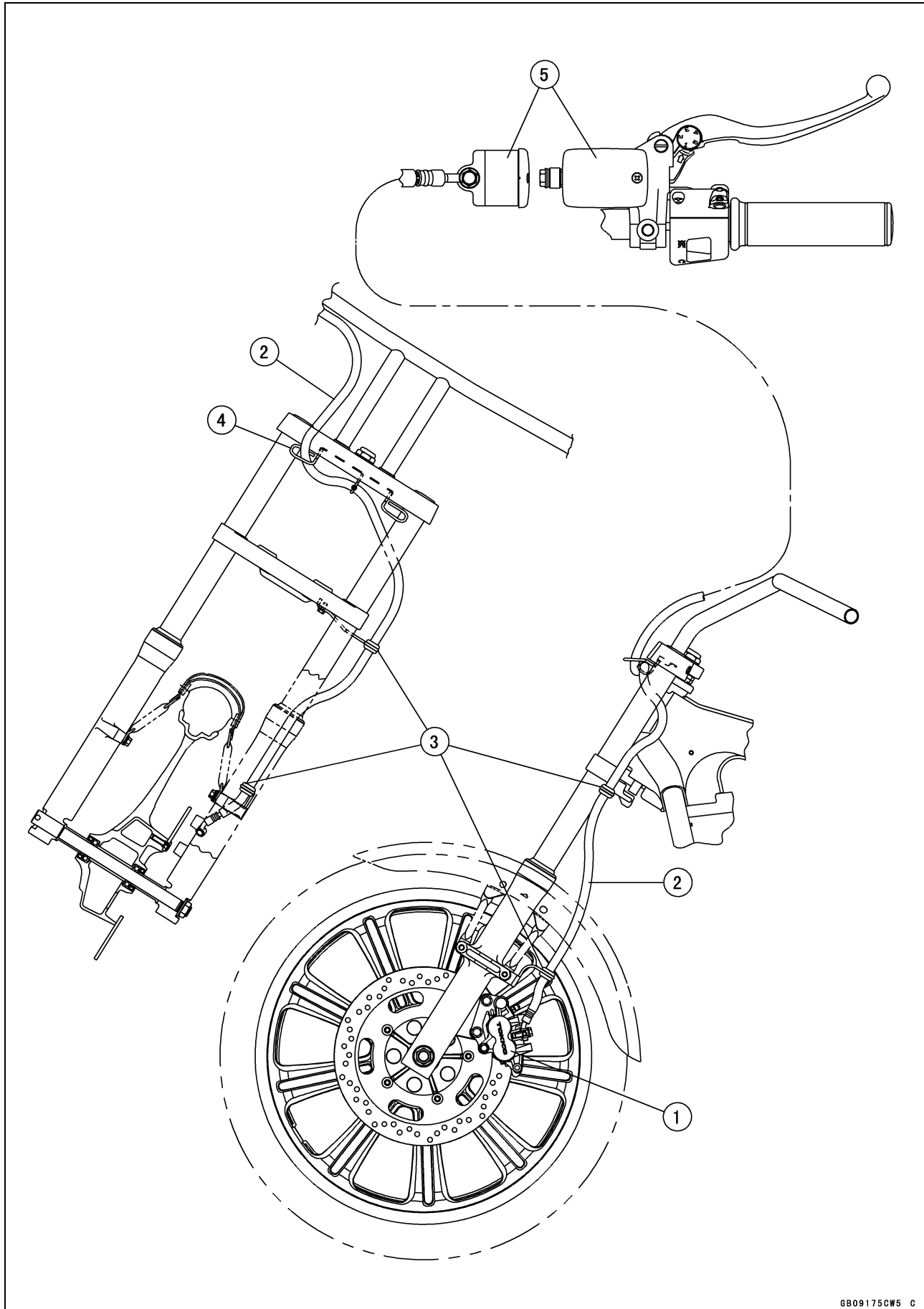

GB09175CW5 C

Cable, Wire, and Hose Routing

1. Front Caliper
2. Brake Hose
3. Clamps
4. Through the brake hose in the bracket.
5. Front Master Cylinder

17-36 APPENDIX

Cable, Wire, and Hose Routing

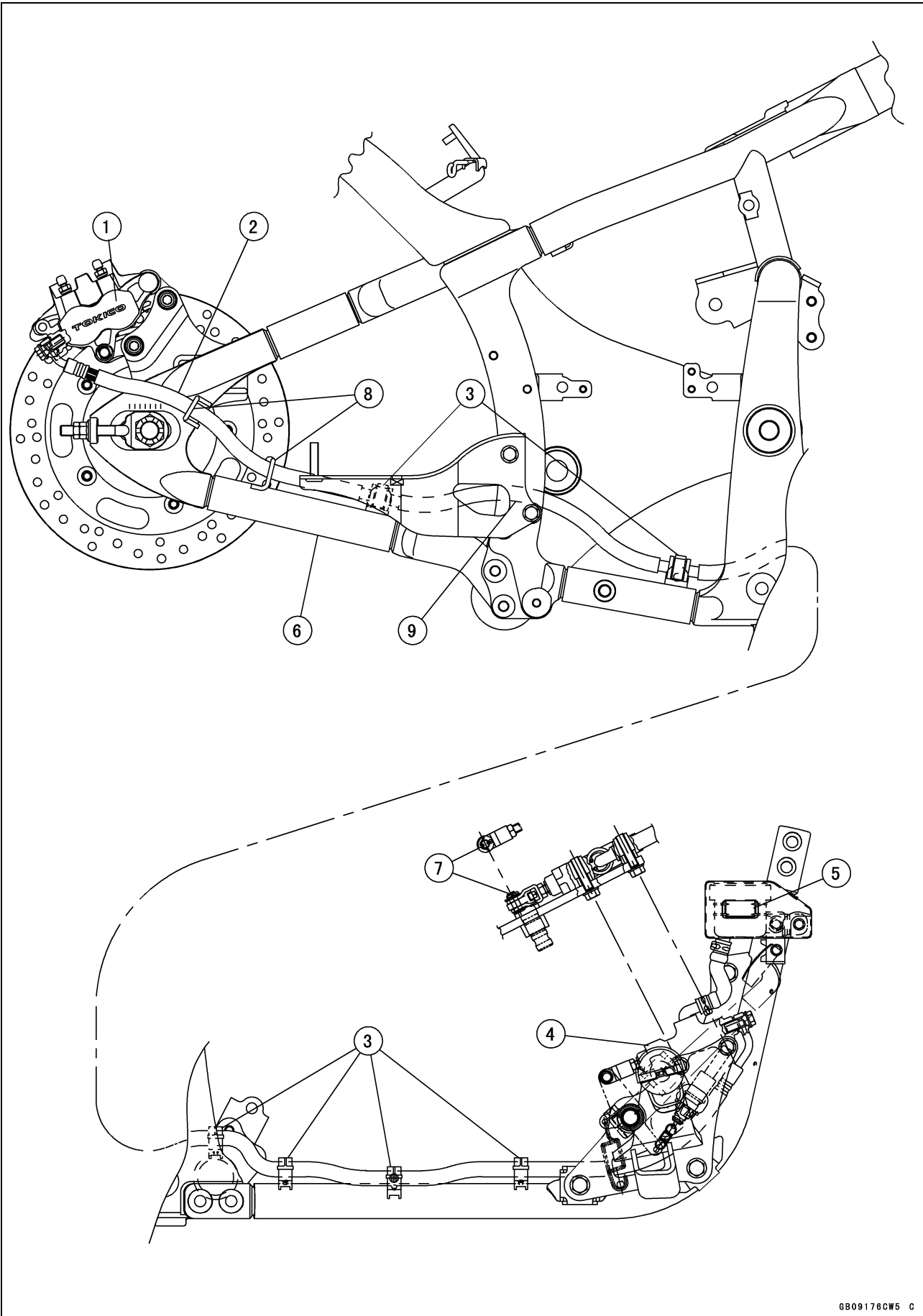

GB09176CW5 C

Cable, Wire, and Hose Routing

1. Rear Caliper
2. Brake Hose
3. Clamps
4. Rear Master Cylinder
5. Reservoir Tank
6. Swingarm
7. Cotter Pin
8. Swingarm Clamps
9. Run the brake hose between the swingarm and frame.

17-38 APPENDIX

Cable, Wire, and Hose Routing

CAL, TH and SEA-B1 Models

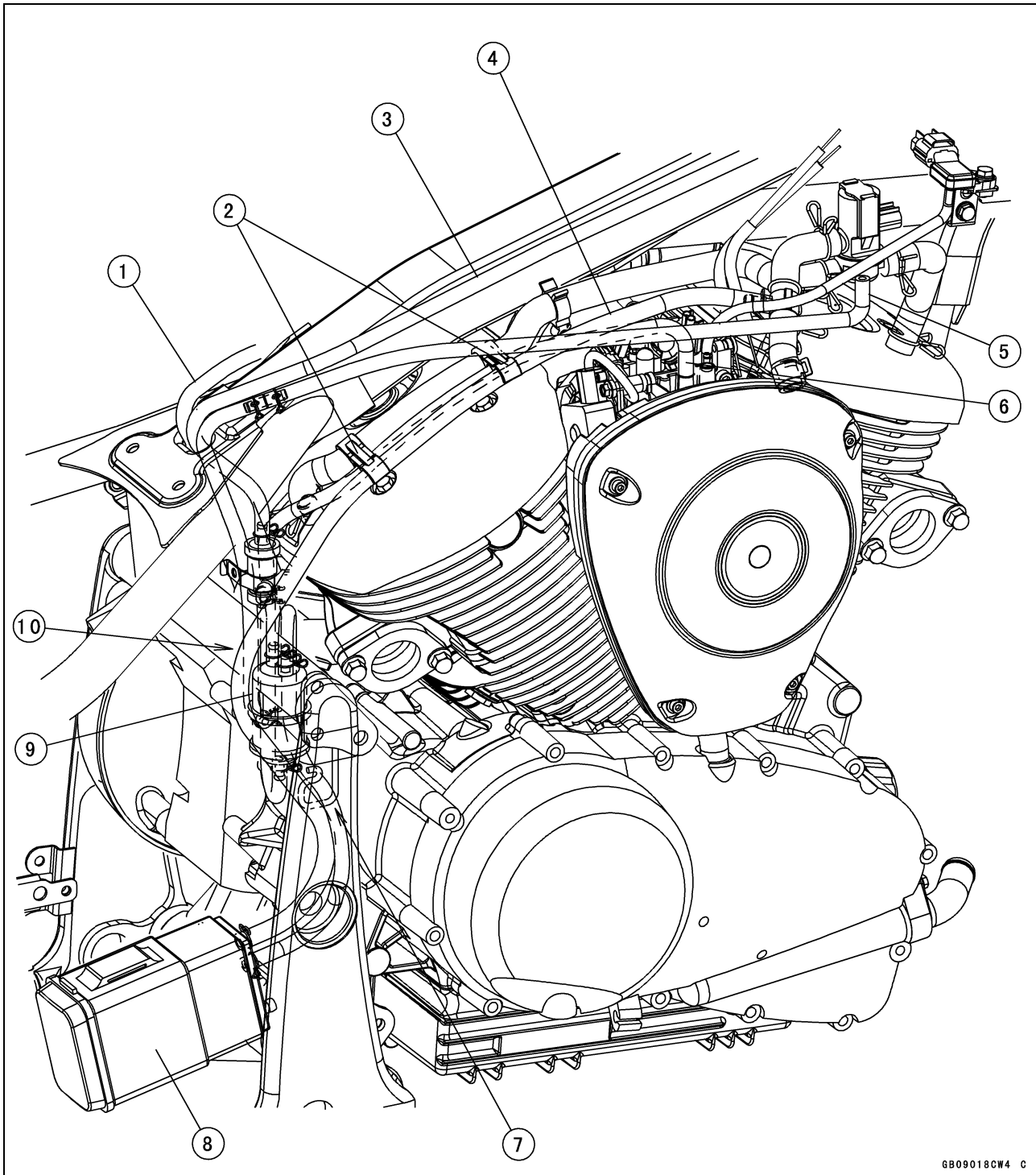

GB09018CW4 C

1. Reserve Tank Hose
2. Clamp the air switching valve hose, vacuum hose (white) and purge hose (green).
3. Breather Hose
4. Purge Hose (Green)
5. Fuel Return Hose (Red)
6. Vacuum Hose (White)
7. Through the breather hose (blue) to the engine bracket clamp.
8. Canister
9. Separator
10. Run the purge hose (green) through the frame cross pipe backward.

Cable, Wire, and Hose Routing

VN900C9 Models

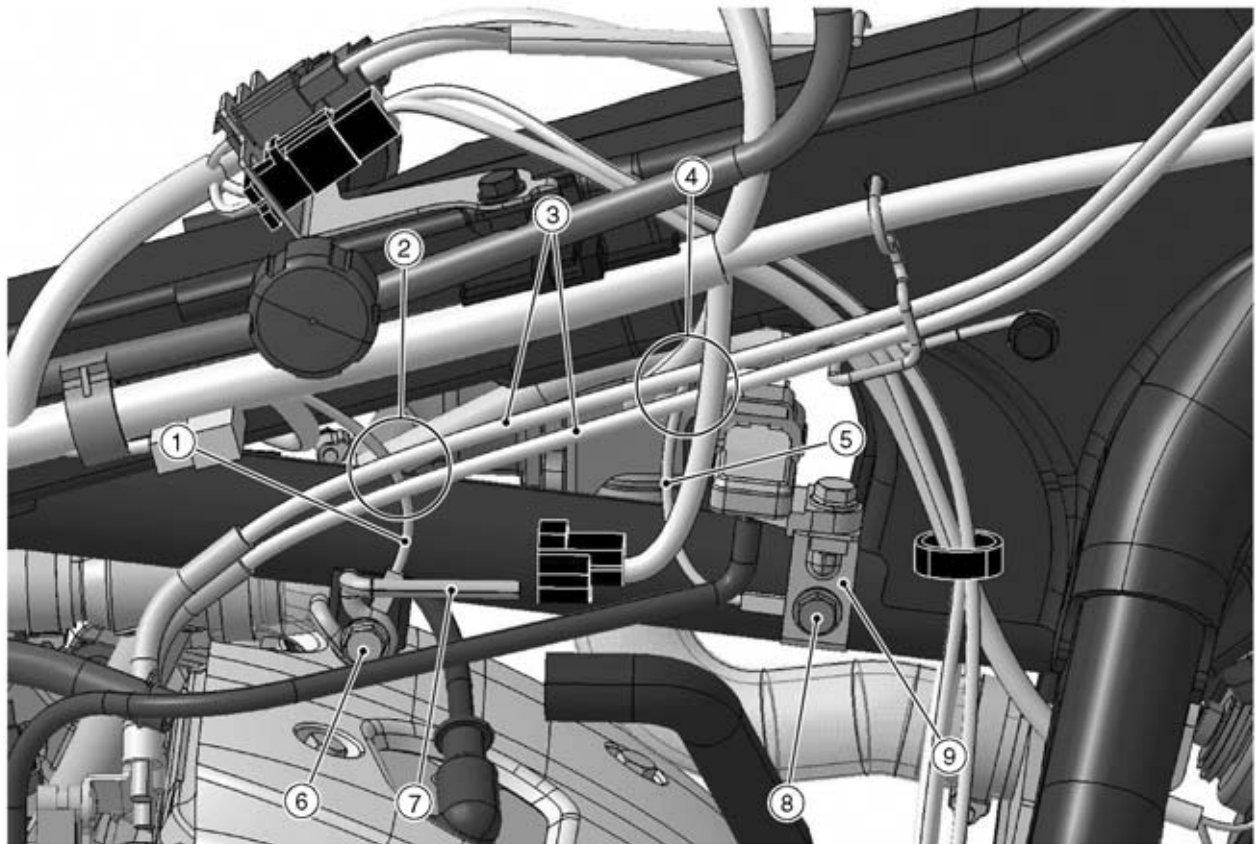

GB09899C G

1. Frame earth lead
2. Run the frame earth lead inside the throttle cables.
3. Throttle Cables
4. Run the frame earth lead inside the throttle cables.
5. Frame earth lead
6. Insert the frame earth terminal between the frame and the air switching valve clamp, and tighten the bolt together with the frame earth terminal and the air switching valve clamp.
7. Air Switching Valve Clamp
8. Insert the frame earth terminal between the frame and the Inlet air pressure sensor holder, and tighten the bolt together with the frame earth terminal and the Inlet air pressure sensor holder.
9. Inlet Air Pressure Sensor Holder

Troubleshooting Guide

NOTE

- Refer to the *Fuel System* chapter for most of DFI trouble shooting guide.
- This is not an exhaustive list, giving every possible cause for each problem listed. It is meant simply as a rough guide to assist the troubleshooting for some of the more common difficulties.

Engine Doesn't Start, Starting Difficulty:

Starter motor not rotating:

- Starter lockout switch or neutral switch trouble
- Starter motor trouble
- Battery voltage low
- Starter relay not contacting or operating
- Starter button not contacting
- Wiring open or shorted
- Ignition switch trouble
- Engine stop switch trouble
- Fuse blown

Starter motor rotating but engine doesn't turn over:

- Starter clutch trouble
- Vehicle-down sensor (DFI) coming off

Engine won't turn over:

- Valve seizure
- Valve lifter seizure
- Cylinder, piston seizure
- Crankshaft seizure
- Connecting rod small end seizure
- Connecting rod big end seizure
- Transmission gear or bearing seizure
- Camshaft seizure
- Balancer Bearing seizure

No fuel flow:

- No fuel in tank
- Fuel pump trouble
- Fuel tank air vent obstructed
- Fuel filter clogged
- Fuel line clogged

Engine flooded:

- Clean spark plug and adjust plug gap
- Starting technique faulty
- (When flooded, do not crank the engine with the throttle fully opened. This promotes engine flood because more fuel is supplied automatically by DFI.)

No spark; spark weak:

- Vehicle-down sensor (DFI) coming off
- Ignition switch not ON
- Engine stop switch turned OFF
- Clutch lever not pulled in or gear not in neutral
- Battery voltage low

- Spark plug dirty, broken, or gap maladjusted
- Spark plug cap or high tension wiring trouble
- Spark plug cap shorted or not in good contact
- Spark plug incorrect
- IC igniter in ECU trouble
- Neutral, starter lockout, or sidestand switch trouble
- Crankshaft sensor trouble
- Ignition coil trouble
- Ignition switch or engine stop switch shorted
- Wiring shorted or open
- Fuse blown

Fuel/air mixture incorrect:

- Bypass screw and/or idle adjusting screw maladjusted
- Air cleaner clogged, poorly sealed, or missing

Compression Low:

- Spark plug loose
- Cylinder head not sufficiently tightened down
- No valve clearance
- Cylinder, piston worn
- Piston ring bad (worn, weak, broken, or sticking)
- Piston ring/groove clearance excessive
- Cylinder head gasket damaged
- Cylinder head warped
- Valve spring broken or weak
- Valve not seating properly (valve bent, worn, or carbon accumulation on the seating surface)

Poor Running at Low Speed:

Spark weak:

- Battery voltage low
- Spark plug dirty, broken, or maladjusted
- Spark plug cap or high tension wiring trouble
- Spark plug cap shorted or not in good contact
- Spark plug incorrect
- IC igniter in ECU trouble
- Crankshaft sensor trouble
- Ignition coil trouble

Fuel/air mixture incorrect:

- Air cleaner clogged, poorly sealed, or missing
- Fuel tank air vent obstructed
- Fuel pump trouble
- Throttle body assy holder loose
- Air cleaner duct loose

Troubleshooting Guide

Compression low:

- Spark plug loose
- Cylinder head not sufficiently tightened down
- No valve clearance
- Cylinder, piston worn
- Piston ring bad (worn, weak, broken, or sticking)
- Piston ring/groove clearance excessive
- Cylinder head warped
- Cylinder head gasket damaged
- Valve spring broken or weak
- Valve not seating properly (valve bent, worn, or carbon accumulation on the seating surface)

Backfiring when deceleration:

- Air switching valve broken
- Air suction valve trouble

Other:

- IC igniter in ECU trouble
- Throttle body assy not synchronizing
- Engine oil viscosity too high
- Drive train trouble
- Brake dragging
- Air suction valve trouble
- Air switching valve trouble
- Engine overheating
- Clutch slipping

Poor Running or No Power at High Speed:

Firing incorrect:

- Spark plug dirty, broken, or maladjusted
- Spark plug cap or high tension wiring trouble
- Spark plug cap shorted or not in good contact
- Spark plug incorrect
- Camshaft position trouble
- IC igniter in ECU trouble
- Crankshaft sensor trouble
- Ignition coil trouble

Fuel/air mixture incorrect:

- Air cleaner clogged, poorly sealed, or missing
- Air cleaner O-ring damaged
- Air cleaner duct loose
- Water or foreign matter in fuel
- Throttle body assy holder loose
- Fuel to injector insufficient (DFI)
- Fuel tank air vent obstructed
- Fuel line clogged
- Fuel pump trouble

Compression low:

- Spark plug loose
- Cylinder head not sufficiently tightened down

- No valve clearance
- Cylinder, piston worn
- Piston ring bad (worn, weak, broken, or sticking)
- Piston ring/groove clearance excessive
- Cylinder head gasket damaged
- Cylinder head warped
- Valve spring broken or weak
- Valve not seating properly (valve bent, worn, or carbon accumulation on the seating surface)

Knocking:

- Carbon built up in combustion chamber
- Fuel poor quality or incorrect
- Spark plug incorrect
- IC igniter in ECU trouble
- Crankshaft sensor trouble

Miscellaneous:

- Throttle valve won't fully open
- Brake dragging
- Clutch slipping
- Engine overheating
- Engine oil level too high
- Engine oil viscosity too high
- Drive train trouble
- Air suction valve trouble
- Air switching valve trouble
- Catalytic converter melt down due to muffler overheating (KLEEN)

Overheating:

Firing incorrect:

- Spark plug dirty, broken, or maladjusted
- Spark plug incorrect
- IC igniter in ECU trouble

Muffler overheating:

- For KLEEN, do not run the engine even if with only one cylinder misfiring or poor running (Request the nearest service facility to correct it)
- For KLEEN, do not push-start with a dead battery (Connect another full-charged battery with jumper cables, and start the engine using the electric starter)
- For KLEEN, do not start the engine under misfire due to spark plug fouling or poor connection of the spark plug
- For KLEEN, do not coast the motorcycle with the ignition switch off (Turn the ignition switch ON and run the engine)
- IC igniter in ECU trouble

Fuel/air mixture incorrect:

- Throttle body assy holder loose
- Air cleaner duct loose
- Air cleaner poorly sealed, or missing
- Air cleaner O-ring damaged
- Air cleaner clogged

Troubleshooting Guide

Compression high:

Carbon built up in combustion chamber

Engine load faulty:

Clutch slipping
Engine oil level too high
Engine oil viscosity too high
Drive train trouble
Brake dragging

Lubrication inadequate:

Engine oil level too low
Engine oil poor quality or incorrect

Gauge incorrect:

Water temperature gauge broken
Water temperature sensor broken

Coolant incorrect:

Coolant level too low
Coolant deteriorated
Wrong coolant mixed ratio

Cooling system component incorrect:

Radiator fin damaged
Radiator clogged
Thermostat trouble
Radiator cap trouble
ECU trouble
Radiator fan relay trouble
Fan motor broken
Fan blade damaged
Water pump not turning
Water pump impeller damaged

Over Cooling:

Cooling system component incorrect:

ECU trouble
Radiator fan relay trouble
Thermostat trouble

Clutch Operation Faulty:

Clutch slipping:

Friction plate worn or warped
Steel plate worn or warped
Clutch spring broken or weak
Clutch hub or housing unevenly worn
No clutch lever play
Clutch inner cable trouble
Clutch release mechanism trouble

Clutch not disengaging properly:

Clutch plate warped or too rough
Clutch spring compression uneven
Engine oil deteriorated
Engine oil viscosity too high
Engine oil level too high
Clutch housing frozen on drive shaft
Clutch hub nut loose
Clutch hub spline damaged
Clutch friction plate installed wrong
Clutch lever play excessive
Clutch release mechanism trouble

Gear Shifting Faulty:

Doesn't go into gear; shift pedal doesn't return:

Clutch not disengaging
Shift fork bent or seized
Gear stuck on the shaft
Gear set lever binding
Shift return spring weak or broken
Shift return spring pin loose
Shift mechanism arm spring broken
Shift mechanism arm broken
Shift pawl broken

Jumps out of gear:

Shift fork ear worn, bent
Gear groove worn
Gear dogs and/or dog holes worn
Shift drum groove worn
Gear set lever spring weak or broken
Shift fork guide pin worn
Drive shaft, output shaft, and/or gear splines worn

Overshifts:

Gear set lever spring weak or broken
Shift mechanism arm spring broken

Abnormal Engine Noise:

Knocking:

IC igniter in ECU trouble
Carbon built up in combustion chamber
Fuel poor quality or incorrect
Spark plug incorrect
Overheating

Piston slap:

Cylinder/piston clearance excessive
Cylinder, piston worn
Connecting rod bent
Piston pin, piston pin hole worn

Valve noise:

Valve clearance incorrect
Valve spring broken or weak
Camshaft bearing worn
Valve lifter worn

Other noise:

Connecting rod small end clearance excessive
Connecting rod big end clearance excessive
Piston ring/groove clearance excessive
Piston ring worn, broken, or stuck
Piston ring groove worn
Piston seizure, damage
Cylinder head gasket leaking
Exhaust pipe leaking at cylinder head connection
Crankshaft runout excessive
Engine mount loose
Crankshaft bearing worn

Troubleshooting Guide

Primary gear worn or chipped
 Camshaft chain tensioner trouble
 Camshaft chain, sprocket, guide worn
 Air suction valve damaged
 Air switching valve damaged
 Alternator rotor loose
 Catalytic converter melt down due to muffler overheating (KLEEN)

Abnormal Drive Train Noise:

Clutch noise:

Clutch housing/friction plate clearance excessive
 Clutch housing gear worn
 Wrong installation of outside friction plate

Transmission noise:

Bearings worn
 Transmission gear worn or chipped
 Metal chips jammed in gear teeth
 Engine oil insufficient

Drive line noise:

Drive belt adjusted improperly
 Drive belt worn
 Rear and/or engine pulley worn
 Rear wheel misaligned

Abnormal Frame Noise:

Front fork noise:

Oil insufficient or too thin
 Spring weak or broken

Rear shock absorber noise:

Shock absorber damaged

Disc brake noise:

Pad installed incorrectly
 Pad surface glazed
 Disc warped
 Caliper trouble

Other noise:

Bracket, nut, bolt, etc. not properly mounted or tightened

Oil Pressure Warning Light Goes On:

Engine oil pump damaged
 Engine oil screen clogged
 Engine oil filter clogged
 Engine oil level too low
 Engine oil viscosity too low
 Camshaft bearing worn
 Crankshaft bearing worn
 Oil pressure switch damaged
 Wiring faulty
 Relief valve stuck open
 O-ring at the oil passage in the crankcase damaged

Exhaust Smokes Excessively:

White smoke:

Piston oil ring worn
 Cylinder worn
 Valve oil seal damaged
 Valve guide worn
 Engine oil level too high

Black smoke:

Air cleaner clogged

Brown smoke:

Air cleaner duct loose
 Air cleaner O-ring damaged
 Air cleaner poorly sealed or missing

Handling and/or Stability

Unsatisfactory:

Handlebar hard to turn:

Cable routing incorrect
 Hose routing incorrect
 Wiring routing incorrect
 Steering stem nut too tight
 Steering stem bearing damaged
 Steering stem bearing lubrication inadequate
 Steering stem bent
 Tire air pressure too low

Handlebar shakes or excessively vibrates:

Tire worn
 Swingarm pivot bearing worn
 Rim warped, or not balanced
 Wheel bearing worn
 Handlebar clamp nut loose
 Steering stem nut loose
 Front, rear axle runout excessive
 Engine mounting bolt loose

Handlebar pulls to one side:

Frame bent
 Wheel misalignment
 Swingarm bent or twisted
 Swingarm pivot shaft runout excessive
 Steering maladjusted
 Front fork bent
 Right and left front fork oil level uneven

Shock absorption unsatisfactory:

(Too hard)
 Front fork oil excessive
 Front fork oil viscosity too high
 Rear shock absorber adjustment too hard
 Tire air pressure too high
 Front fork bent
 (Too soft)
 Tire air pressure too low
 Front fork oil insufficient and/or leaking
 Front fork oil viscosity too low
 Rear shock adjustment too soft
 Front fork, rear shock absorber spring weak
 Rear shock absorber oil leaking

17-44 APPENDIX

Troubleshooting Guide

Brake Doesn't Hold:

- Air in the brake line
- Pad or disc worn
- Brake fluid leakage
- Disc warped
- Contaminated pad
- Brake fluid deteriorated
- Primary or secondary cup damaged in master cylinder
- Master cylinder scratched inside

Battery Trouble:

Battery discharged:
Charge insufficient

- Battery faulty (too low terminal voltage)
- Battery cable making poor contact
- Load excessive (e.g., bulb of excessive wattage)
- Ignition switch trouble
- Alternator trouble
- Wiring faulty
- Regulator/rectifier trouble

Battery overcharged:
Alternator trouble
Regulator/rectifier trouble
Battery faulty

MODEL APPLICATION

| Year | Model | Beginning Frame No. |
|------|---------|--|
| 2007 | VN900C7 | JKAVN2C1□7A000001 JKAVN900CCA000001 |
| 2008 | VN900C8 | JKAVN2C1□8A015001 JKAVN900CCA015001 |
| 2009 | VN900C9 | JKAVN2C1□9A025001 JKAVN900CCA025001 |
| 2010 | VN900CA | JKAVN2C1□AA037001 JKAVN900CCA037001 |
| 2011 | VN900CB | JKAVN2C1□BA045001 JKAVN900CCA045001 |
| 2012 | VN900CC | JKAVN2C1□CA049001 JKAVN900CCA049001 |
| 2013 | VN900CD | JKAVN2C1□DA054001 JKAVN900CCA054001 |
| 2014 | VN900CE | JKAVN2C1□EA057001 JKAVN900CCA057001 |
| 2015 | VN900CF | JKAVN2C1□FA062001 JKAVN900CCA062001 |

□:This digit in the frame number changes from one machine to another.